

Crystalfontz America, Inc.

CUSTOMER : _____

MODULE NO.: CFAX12864CP1-WGH-TS

SALES BY	APPROVED BY	CHECKED BY	PREPARED BY
ISSUED DATE:			

Crystalfontz America, Inc.

12412 East Saltese Avenue
Spokane Valley, WA 99216-0357

Phone: (888) 206-9720

Fax: (509) 892-1203

Email: techinfo@crystalfontz.com

URL: www.crystalfontz.com

Contents

- 1.Module Classification Information
- 2.Precautions in use of LCD Modules
- 3.General Specification
- 4.Absolute Maximum Ratings
- 5.Electrical Characteristics
- 6.Optical Characteristics
- 7.Interface Description
- 8.Contour Drawing & Block Diagram
9. Display Control Instruction
- 10.Backlight Information
- 11.Touch Panel Information

1.Module Classification Information

CFA X 1 2 8 6 4 C P1 - W G H - T S

① ② ③ ④⑧ ⑤⑥⑦ ⑨

①	Brand : CRYSTALFONTZ AMERICA, INCORPORATED													
②	Display Type : H→Character Type, G→Graphic Type, X→TAB Type													
③	Display's logical dimensions: 128 pixels by 64 pixels													
④	Model serials no.													
⑤	Backlight Type :	<table border="0"> <tr> <td>N→Without backlight</td> <td>P→LED, Bule</td> </tr> <tr> <td>B→EL, Blue green</td> <td>A→LED, Amber</td> </tr> <tr> <td>D→EL, Green</td> <td>R→LED, Red</td> </tr> <tr> <td>W→EL, White</td> <td>O→LED, Orange</td> </tr> <tr> <td>F→CCFL, White</td> <td>G→LED, Green</td> </tr> <tr> <td>Y→LED, Yellow Green</td> <td>T→LED, White</td> </tr> </table>	N→Without backlight	P→LED, Bule	B→EL, Blue green	A→LED, Amber	D→EL, Green	R→LED, Red	W→EL, White	O→LED, Orange	F→CCFL, White	G→LED, Green	Y→LED, Yellow Green	T→LED, White
N→Without backlight	P→LED, Bule													
B→EL, Blue green	A→LED, Amber													
D→EL, Green	R→LED, Red													
W→EL, White	O→LED, Orange													
F→CCFL, White	G→LED, Green													
Y→LED, Yellow Green	T→LED, White													
⑥	LCD Mode :	<table border="0"> <tr> <td>B→TN Positive, Gray</td> <td>T→FSTN Negative</td> </tr> <tr> <td>N→TN Negative,</td> <td></td> </tr> <tr> <td>G→STN Positive, Gray</td> <td></td> </tr> <tr> <td>Y→STN Positive, Yellow Green</td> <td></td> </tr> <tr> <td>M→STN Negative, Blue</td> <td></td> </tr> <tr> <td>F→FSTN Positive</td> <td></td> </tr> </table>	B→TN Positive, Gray	T→FSTN Negative	N→TN Negative,		G→STN Positive, Gray		Y→STN Positive, Yellow Green		M→STN Negative, Blue		F→FSTN Positive	
B→TN Positive, Gray	T→FSTN Negative													
N→TN Negative,														
G→STN Positive, Gray														
Y→STN Positive, Yellow Green														
M→STN Negative, Blue														
F→FSTN Positive														
⑦	LCD Polarizer Type/ Temperature range/ View direction	<table border="0"> <tr> <td>A→Reflective, N.T, 6:00</td> <td>H→Transflective, W.T,6:00</td> </tr> <tr> <td>D→Reflective, N.T, 12:00</td> <td>K→Transflective, W.T,12:00</td> </tr> <tr> <td>G→Reflective, W. T, 6:00</td> <td>C→Transmissive, N.T,6:00</td> </tr> <tr> <td>J→Reflective, W. T, 12:00</td> <td>F→Transmissive, N.T,12:00</td> </tr> <tr> <td>B→Transflective, N.T,6:00</td> <td>I→Transmissive, W. T, 6:00</td> </tr> <tr> <td>E→Transflective, N.T,12:00</td> <td>L→Transmissive, W.T,12:00</td> </tr> </table>	A→Reflective, N.T, 6:00	H→Transflective, W.T,6:00	D→Reflective, N.T, 12:00	K→Transflective, W.T,12:00	G→Reflective, W. T, 6:00	C→Transmissive, N.T,6:00	J→Reflective, W. T, 12:00	F→Transmissive, N.T,12:00	B→Transflective, N.T,6:00	I→Transmissive, W. T, 6:00	E→Transflective, N.T,12:00	L→Transmissive, W.T,12:00
A→Reflective, N.T, 6:00	H→Transflective, W.T,6:00													
D→Reflective, N.T, 12:00	K→Transflective, W.T,12:00													
G→Reflective, W. T, 6:00	C→Transmissive, N.T,6:00													
J→Reflective, W. T, 12:00	F→Transmissive, N.T,12:00													
B→Transflective, N.T,6:00	I→Transmissive, W. T, 6:00													
E→Transflective, N.T,12:00	L→Transmissive, W.T,12:00													
⑧	Special Code	P1/P: "A" module with ZIF tail												
⑨	Special Code	TS→Touchpanel												

2.Precautions in use of LCD Modules

- (1) Avoid applying excessive shocks to the module or making any alterations or modifications to it.
- (2) Don't make extra holes on the printed circuit board, modify its shape or change the components of LCD module.
- (3) Don't disassemble the LCM.
- (4) Don't operate it above the absolute maximum rating.
- (5) Don't drop, bend or twist LCM.
- (6) Soldering: only to the I/O terminals.
- (7) Storage: please storage in anti-static electricity container and clean environment.

3.General Specification

Item	Dimension	Unit
Number of Characters	128 x 64	-
Module dimension	83.9 x 56.0 x 1.9(MAX)	mm
View area	52.0x 33.5	mm
Active area	47.34x 26.86	mm
Dot size	0.35 x 0.4	mm
Dot pitch	0.37 x 0.42	mm
LCD type	STN Positive, Transflective, Gray	
Duty	1/64	
View direction	6 o'clock	
Backlight Type	EL WHITE	

4. Absolute Maximum Ratings

Item	Symbol	Min	Typ	Max	Unit
Operating Temperature	T_{OP}	-20	-	+70	°C
Storage Temperature	T_{ST}	-30	-	+80	°C
Input Voltage	V_I	V_{SS}	-	V_{DD}	V
Supply Voltage For Logic	$V_{DD}-V_{SS}$	2.4	-	3.6	V
Supply Voltage For LCD	V_O-V_{SS}	4.0	-	15.0	V

5. Electrical Characteristics

Item	Symbol	Condition	Min	Typ	Max	Unit
Supply Voltage For Logic	$V_{DD}-V_{SS}$	-	2.4	-	3.6	V
Supply Voltage For LCD	$V_{DD}-V_0$	$T_a=-20^{\circ}\text{C}$	-	-	9.2	V
		$T_a=25^{\circ}\text{C}$	-	8.2	-	V
		$T_a=+70^{\circ}\text{C}$	7.2	-	-	V
Input High Volt.	V_{IH}	-	$0.8 V_{DD}$	-	V_{DD}	V
Input Low Volt.	V_{IL}	-	-	-	$0.2V_{DD}$	V
Output High Volt.	V_{OH}	-	$V_{DD} - 0.4$	-	-	V
Output Low Volt.	V_{OL}	-	-	-	0.4	V
Supply Current	I_{DD}	$V_{DD}=3.6$	-	80	-	mA

6. Optical Characteristics

Item	Symbol	Condition	Min	Typ	Max	Unit
View Angle	(V) θ	$CR \geq 3$	15	-	105	deg
	(H) ϕ	$CR \geq 3$	-30	-	30	deg
Contrast Ratio	CR	-	-	3	-	-
Response Time	T rise	-	-	110	220	ms
	T fall	-	-	260	520	ms

6.1 Definitions

■ View Angles

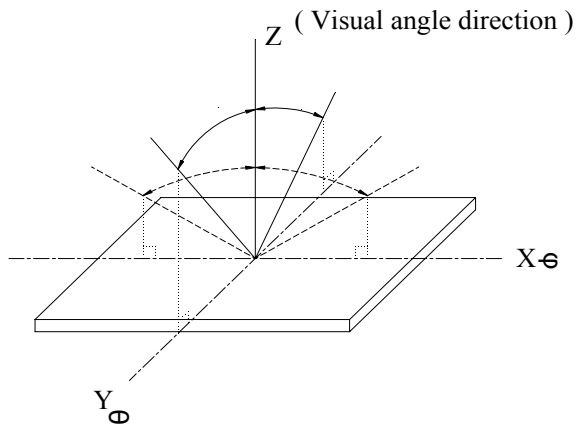

■ Contrast Ratio

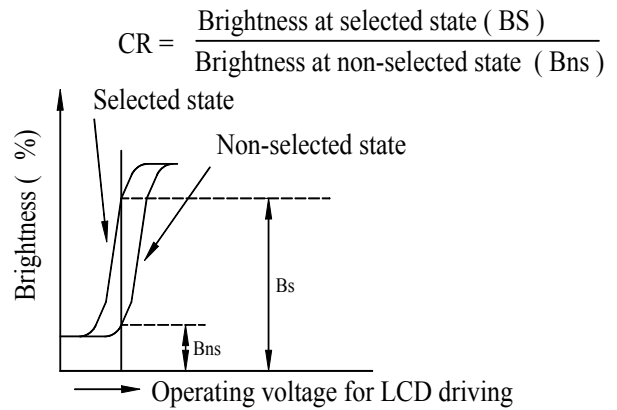

■ Response Time

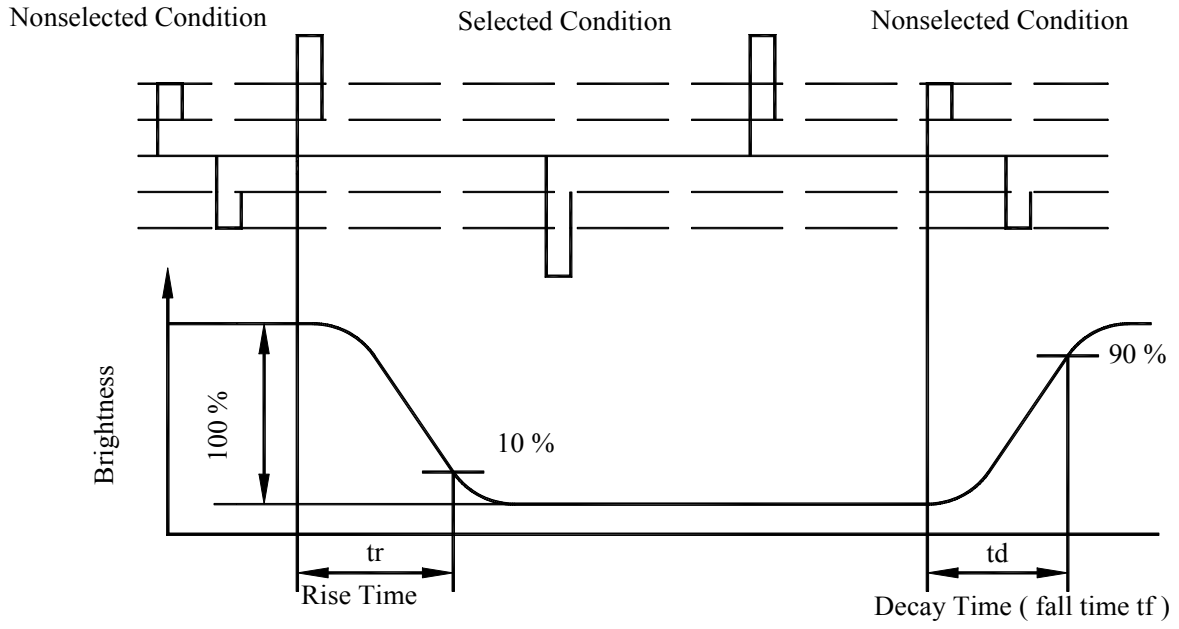

7.Interface Description

Pin No.	Symbol	I/O	Description
1	VDD	-	Power supply pin for logic.
2	VSS	-	Ground pin, connected to 0V
3	CS1B	I	Chip select input pins Data/instruction i/o is enabled only when CS1Bis”L”and CS2”H”. When chip select is non-active,DB0 TO DB7 may be high impedance.
4	CS2	I	Chip select input pins Data/instruction i/o is enabled only when CS1Bis”L”and CS2”H”. When chip select is non-active,DB0 TO DB7 may be high impedance.
5	RES	I	Reset input pin When RESETB is “L”, initialization is executed.
6	RS	I	Register select input pin -RS = “H”:DB0 to DB7 are display data -RS = “L” :DB0 to DB7 are control data
7	R/W	I	When connected to 80-family MPU: Write enable clock input pin. The data ON DB0~DB7 are latched at the rising edge of the /WR signal. When connected to 68-family MPU: RW = ”H”: read RW = “L”: write
8	E	I	When connected to 80-family MPU: Read enable clock input pin. When /RD is “L”, DB0~DB7 are in an output status When connected to 68-family MPU: RW = ”H”: When E is “H”, DB0~DB7 are in an output status RW = “L”: The data on DB0~DB7 are latched at the falling edge of the E signal

Pin No.	Symbol	I/O	Description												
9~16	DB0~DB7	I/O	<p>8-bit bi-directional data bus that is connected to the standard 8-bit microprocessor data bus.</p> <p>When the serial interface selected(PS="L")</p> <p>DB0~DB5: high impedance</p> <p>DB6: serial input clock (SCLK)</p> <p>DB7: serial input data (SID)</p> <p>When chip select is not active, DB0~DB7 may be high impedance.</p>												
17	MI	I	<p>Microprocessor interface selects pin.</p> <p>MI="H": 6800-series MPU interface</p> <p>MI="L": 8080-series MPU interface</p>												
18	PS	I	<p>Parallel/Serial data input select pin.</p> <table border="0" style="margin-left: auto; margin-right: auto;"> <tr> <td style="padding: 0 10px;">Interface</td> <td style="padding: 0 10px;">Data</td> <td style="padding: 0 10px;">Read/Write</td> <td style="padding: 0 10px;">Serial clock</td> </tr> <tr> <td>PS="H": Parallel</td> <td>DB0~DB7</td> <td>E_RD,RW_WR</td> <td>-</td> </tr> <tr> <td>PS="L": Serial</td> <td>SID(DB7)</td> <td>Write only</td> <td>SCLK(DB6)</td> </tr> </table> <p>In serial mode, it is impossible to read data from the on-chip RAM. And DB0 to DB5 are high impedance and E_RD and RW_WR must be fixed to either "H" or "L".</p>	Interface	Data	Read/Write	Serial clock	PS="H": Parallel	DB0~DB7	E_RD,RW_WR	-	PS="L": Serial	SID(DB7)	Write only	SCLK(DB6)
Interface	Data	Read/Write	Serial clock												
PS="H": Parallel	DB0~DB7	E_RD,RW_WR	-												
PS="L": Serial	SID(DB7)	Write only	SCLK(DB6)												

9.Display Control Instruction

PLEASE CONSULT KS0713 DATA SHEET

10.Backlight Information

PARAMETER	SYMBOL	MIN	TYP	MAX	UNIT	TEST CONDITION
Drive Voltage	Vmax	78	—	85	Vrms	25°C
Drive Wave	Fmax	400	—	1000	Hz	25°C
Brightness		65	-	-	cd/m ²	78~85Vrms/400~1000Hz
Power Consumption		-	43.55	-	mW	78~85Vrms/400~1000Hz
Chromatism	X	-	0.330	-	-	78~85Vrms/400~1000Hz
	Y	-	0.365	-	-	78~85Vrms/400~1000Hz
Life time		5000			hour	78~85Vrms/400~1000Hz
Color		white			-	-

11.Touch Screen

1. General

- 1.1 This document includes the specification of PN4-025F-01N touch screen.
- 1.2 This touch screen is 4 wires analog resistive type.
- 1.3 It is based on one ITO glass sheet with one layer of ITO PET on top.
- 1.4 The PET is coated with ITO and is separated with printed spacers.
- 1. It is designed to be activated by pressure of finger or stylus.
- 2.

2. Environment

2.1 Storing Environment

Temperature Range: -20 deg C ~ 70 deg C
Humidity Range: 10% RH ~ 90% RH

2.2 Operating Environment

Temperature Range: 0 deg C ~ 50 deg C
Humidity Range: 20% RH ~ 80% RH

- 2. The above environment is under normal pressure of the atmosphere.

3. Mechanical Specification

3.1 Touch panel style

style: Analog resistance

3.2 Dimension Specifications:

Dimension Outline	63.5mm ±0.3mm x 41.5mm ±0.3mm
Viewable area	56.70mm x 35.00mm
Active area	54.40mm x 32.40mm
PET thickness	max. 200µm
Glass thickness	1.1mm

3.3 Dot Spacer Specifications :

- (1) Diameter: 0.05 mm ±0.01 mm
- (2) Height: 5 um ~ 10 um
- (3) Pitch: 3 mm
- (4) Pattern: rhombus
- (5) Operative Force: ≤ 40g

3.4 Surface Hardness PET: ≥ 3H

3.5 Transparency

Non-Glare Panel: $\geq 70\%$, Wave length at 450~700nm

4. Electrical Specification

Film resistance between leads: $150\Omega \sim 1300\Omega$

Glass resistance between leads: $150\Omega \sim 1300\Omega$

Operative resistance: $\leq 2K\Omega$

Linearity deviation: $\leq 2.0\%$

Insulation resistance: $\geq 20M\Omega/25V$.

(The ON Resistance is measured when the panel is pressed by R8 , HS60 silicon rubber at 80 g force).

5. Quality Standard

5.1 Resistance against chemicals

The panel could be cleaned with cloth containing ethanol or neutral cleaner. It is no effects to the characteristics.

5.2 Dirt and Flaws on Panel Surface

The flaws and Impurities are allowed outside viewing area except those affecting electrical functions.

Inside the viewing area , it meets the following :

5.3 Within viewable area (PANEL) :

(1) Hair Flaws:

$W \leq 0.05 \text{ mm}$, $L \leq 12 \text{ mm}$: OK

$0.05 \text{ mm} < W \leq 0.1 \text{ mm}$, $L \leq 5 \text{ mm}$: 3 or less are OK

$W > 0.1 \text{ mm}$, $L > 2 \text{ mm}$: fail

(W = width of flaws , L = length of flaws)

(2) Dot-shaped Impurities :

$D \leq 0.1 \text{ mm}$: OK

$0.1 \text{ mm} < D \leq 0.3 \text{ mm}$: 5 or less are OK

$D > 0.3 \text{ mm}$: fail

(D : average of diameter)

(3) Scratch :

$W \leq 0.05 \text{ mm}$, $L \leq 12 \text{ mm}$: OK

0.05 mm < W ≤ 0.1 mm, L ≤ 12 mm: 5 or less are OK
W > 0.1 mm, L > 12 mm: fail
(W : width of scratch , L : length of scratch)

5.4 Glass Sheet

- (1) Glass Sheet Cracks and Chips: No Cracks and Chips on the Glass Sheet.
 - (2) The angle chips are smaller than 2.5 mm x 2.5 mm x 1.1 mm
(X x Y x Z)
 - (3) The border chips are smaller than 5 mm x 2 mm x 1.1 mm
(X x Y x Z)
- X : Width direction against the edge line.
Y : Length direction against the edge line.
Z : Thickness direction against the edge line.

The chips are not supposed to affect any of the electrical functions.

6. Durability

Keystroke Durability

No damages or malfunctions should occur after 1,000,000 keystrokes as the following :

Keystroke element : R8 , HS40 silicon rubber
Keystroke load : 150 g
Keystroke speed : 0.33 sec/stroke
Keystroke position : Any position in active area
Temperature and humidity : Normal

7. Reliability

7.1 High temperature test

After putting panels at 60°C for 120 hours , they meet the electrical specification required in section 4.

7.2 Low temperature test

After putting panels at -20°C for 120 hours , they meet the electrical specification required in section 4.

7.3 Temperature and humidity test

After putting panels at 60°C , 90% RH for 120 hours , they meet the electrical specification required in section 4.

7.4 Thermal shock test

1 Cycle : -20°C →70°C (30 minutes period)

After putting panels for 10 cycles within 24 hours , they meet the electrical specification required in section 4.

8. Inspection Method

8.1 PET

(1) Linearity

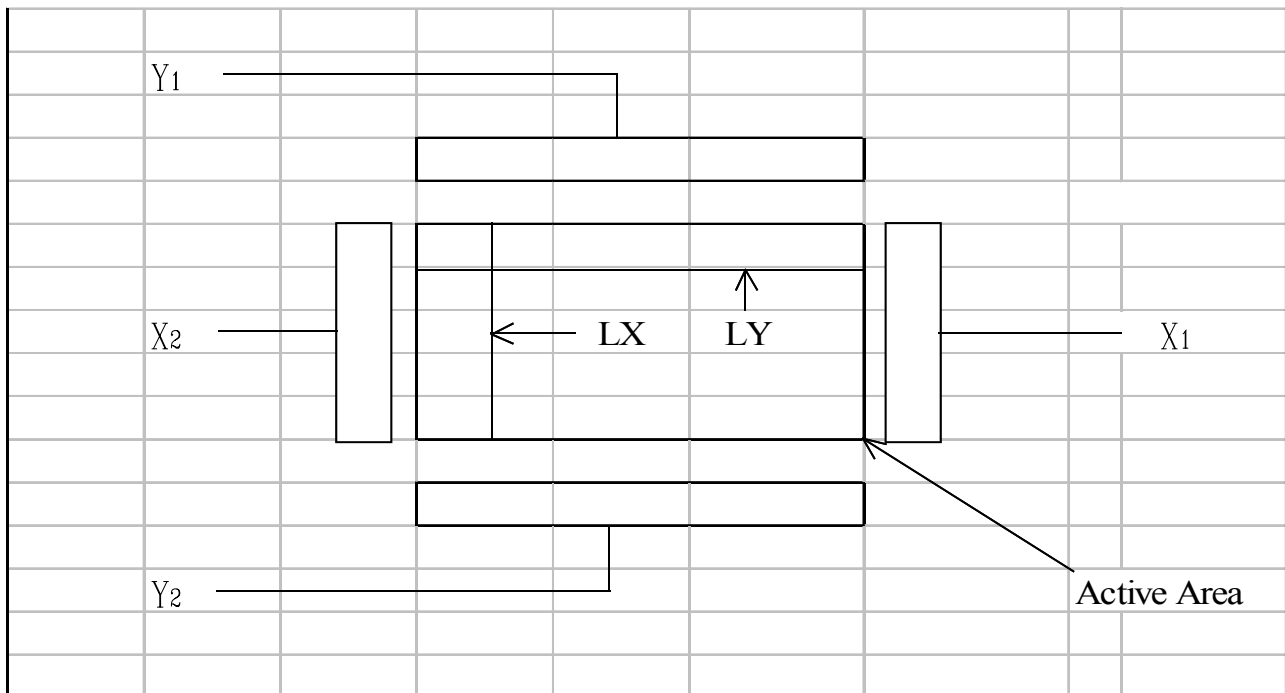

Voltage (DC 5V) is applied to X1 or Y1 and GND to X2 or Y2

By using stylus to cross direct line for every 5 mm step within active area to detect the voltage at Y1 or X1

To measure the voltage difference between X1 and X2 or Y1 and Y2

The voltage variance = ΔE_x or ΔE_y

The linearity must meet the requirement of section 4

(2) Appearance : The inspection shall be performed by using one 17w fluorescent lamp as back or side light . The panel shall be placed at 30cm away from eyes. The panel must meet the requirement of section 5.

8.2 Glass

(1) Linearity : refer to 8.1-(1)

(2) Strength : By using a 9mm diameter steel ball to fall on the panel with height of 30cm , the panel will not be broken.

(3) Appearance : refer to 8.1-(2)

8.3 Tail Bending : By bending the tail 90° around a 2mm cylinder for 3 times , the panels meet the requirement of section 4.

9.Cautions

9.1 The bezel which contacts with PET film should keep a distance at least 3 mm from the active area to avoid short.

9.2 The bezel which contacts with PET film should not place heavy pressure on the film and the surface of bezel should be kept smooth.

9.3 Please keep clean on the surface of PET film , Don't attach any tape on that.

9.4 Neither pull tail upward nor push downward with an angle of 90° It should keep an arch at least R5.

9.5 If there exist any high voltage power , please make an adequate protect.

9.6 To avoid the high voltage static power to damage panel , please don't operate touch panel without connecting controller.

9.7 Ronics retain the right of changing the materials with same grade and specification.