

REV	ENGINEER	DATE	REMARKS
0v0	BAC	2017-12-13	Initial Creation
-	-	-	-
-	-	-	-
-	-	-	-
-	-	-	-

16-BIT "8080" MCU INTERFACE

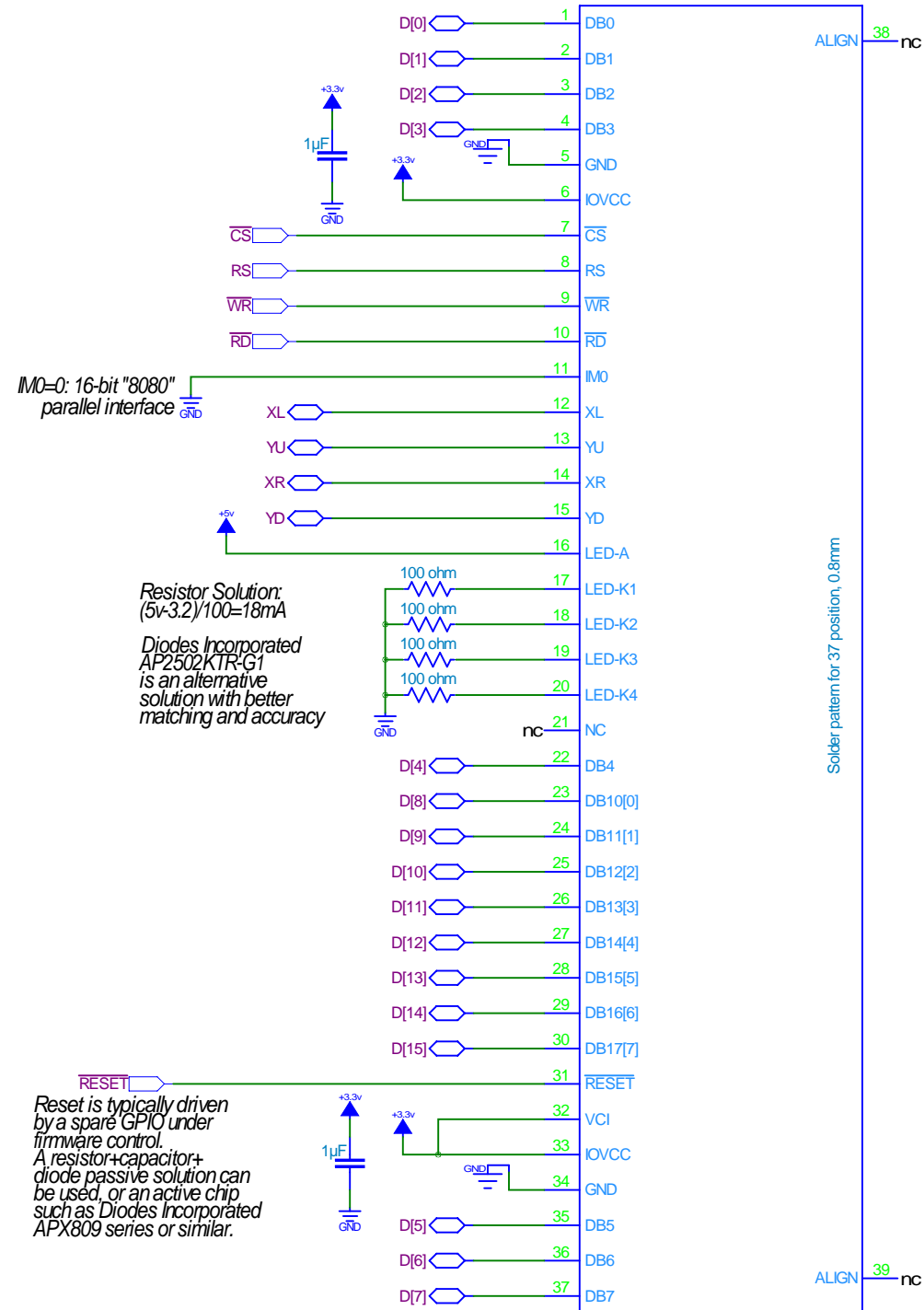

8-BIT "8080" MCU INTERFACE

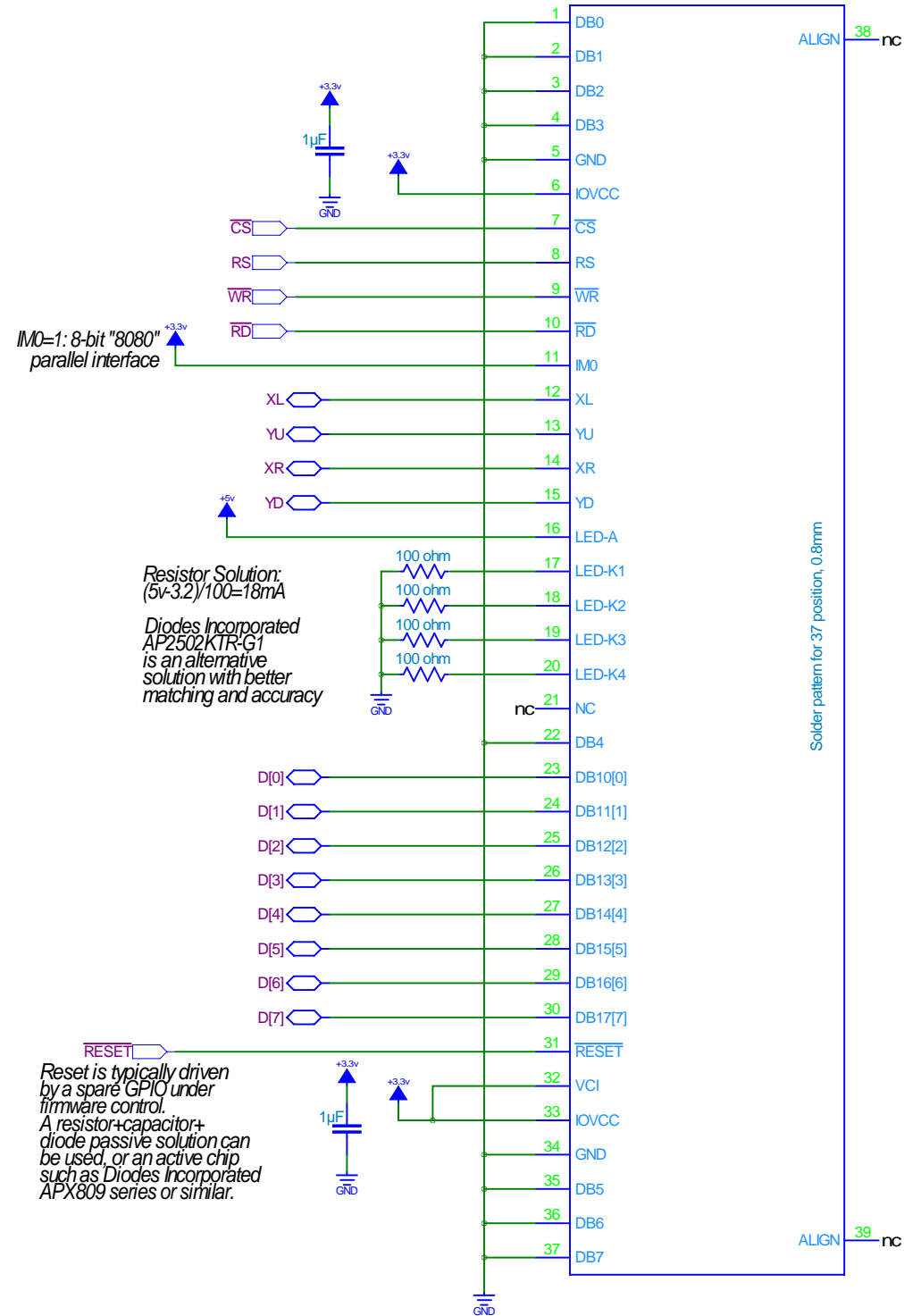

Applicable Module:
CFAF240320K1024TRT

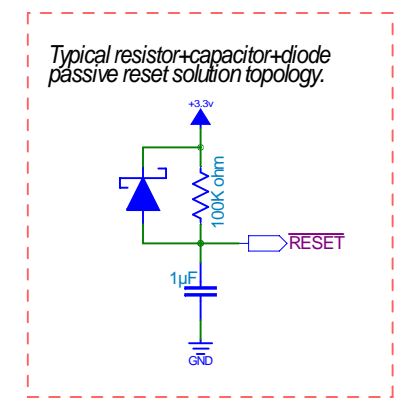

Crystalfontz America, Inc.

Copyright © 2017
Crystalfontz America, Inc.

CFAF240320K1024TRT 2.4" TFT Connection Examples

Page 1/1: -

Example design for reference only.

PRODUCT NAME:	PRODUCT REVISION:	PCB NUMBER:	PCB REVISION:
-	-	-	-