



TFT GRAPHIC DISPLAY MODULE DATASHEET



Datasheet Release Date 2022-03-15
for
CFAF128128B1-0145T

Crystalfontz America, Inc.

12412 East Saltese Avenue
Spokane Valley, WA 99216-0357
Phone: 888-206-9720
Fax: 509-892-1203
Email: support@crystalfontz.com
URL: www.crystalfontz.com

CONTENTS

1. General Information	3
2. Module Description	4
3. Features	4
4. Mechanical Data	4
5. Mechanical Drawing	5
6. System Block Diagram	6
7. Interface Pin Function	7
8. Absolute Maximum Ratings	7
9. Electrical Characteristics	8
10. Optical Characteristics	8
11. Timing Characteristics	9
12. Backlight Characteristics	11
13. LCD Module Precautions	12

1. General Information

Datasheet Revision

Datasheet Release: **2022-03-15**

Product Change Notifications

You can check for or subscribe to [Part Change Notices](#) for this display module on our website.

Variations

Slight variations between lots are normal (e.g., contrast, color, or intensity).

Volatility

This display module has volatile memory.

Disclaimer

Certain applications using CrystalFontz America, Inc. products may involve potential risks of death, personal injury, or severe property or environmental damage ("Critical Applications"). CRYSTALFONTZ AMERICA, INC. PRODUCTS ARE NOT DESIGNED, INTENDED, AUTHORIZED, OR WARRANTED TO BE SUITABLE FOR USE IN LIFE-SUPPORT APPLICATIONS, DEVICES OR SYSTEMS OR OTHER CRITICAL APPLICATIONS. Inclusion of CrystalFontz America, Inc. products in such applications is understood to be fully at the risk of the customer. In order to minimize risks associated with customer applications, adequate design and operating safeguards should be provided by the customer to minimize inherent or procedural hazard. Please contact us if you have any questions concerning potential risk applications.

CrystalFontz America, Inc. assumes no liability for applications assistance, customer product design, software performance, or infringements of patents or services described herein. Nor does CrystalFontz America, Inc. warrant or represent that any license, either express or implied, is granted under any patent right, copyright, or other intellectual property right of CrystalFontz America, Inc. covering or relating to any combination, machine, or process in which our products or services might be or are used.

All specifications in datasheets on our website are, to the best of our knowledge, accurate but not guaranteed. Corrections to specifications are made as any inaccuracies are discovered.

Company and product names mentioned in this publication are trademarks or registered trademarks of their respective owners.

Copyright © 2022 by CrystalFontz America, Inc., 12412 East Saltese Avenue, Spokane Valley, WA 99216 U.S.A.

2. Module Description

This is a full color TFT graphic display module with a white LED backlight, TFT panel, integrated controller/driver, and a Flexible Printed Circuit (FPC) tail. This display requires only a single source for both power supply and logic. This display module has a built-in Sitronix ST7735S, 262K Color Single-Chip TFT Controller.

Please see [Sitronix ST7735S LCD Controller Datasheet](#) for further reference.

3. Features

- 128*128 Dot Matrix
- +3V Power Supply
- Viewing Direction: 6 o'clock
- Built-in Controller: Sitronix ST7735S (or equivalent)
- Operating Temperature: -10°C to +60°C
- Storage Temperature: -10°C to +60°C
- Interface: SPI

4. Mechanical Data

Item	Specification (mm)	Specification (inch, reference)
Overall Module Dimension (without FPC)	33.3 (W) x 38.2 (H) x 2.3 (D)	1.311 (W) x 1.504 (H) x 0.091 (D)
Overall Module Dimension (with FPC)	33.3 (W) x 76.36 (H) x 2.8 (D)	1.311 (W) x 3.006 (H) x 0.110 (D)
Active Area	25.498 (W) x 26.496 (H)	1.004 (W) x 1.043 (H)
Dot Pitch	0.199 (W) x 0.207 (H)	0.007 (W) x 0.008 (H)
Weight (Typical)	4.4 grams	0.16 ounces

5. Mechanical Drawing

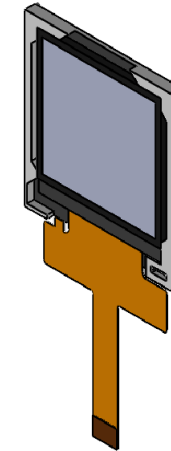
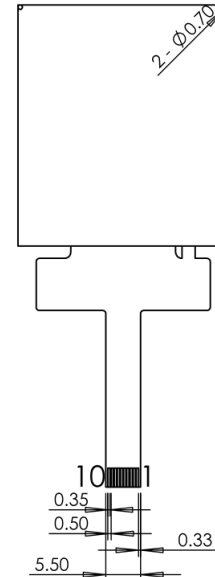
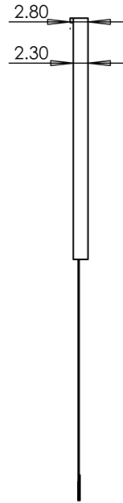
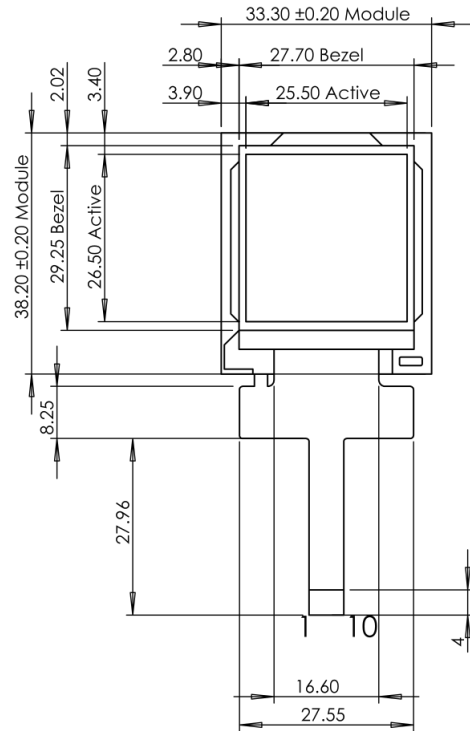

Controller: ST7735S
Viewing direction: 6 o'clock
Storage temperature: -10°C to +60°C
Operating temperature: -10°C to +60°C

Pin	Symbol
1	A (LED+)
2	K (LED-)
3	SPI4W
4	VDD
5	GND
6	CS
7	RST
8	SDA
9	SCL
10	D/C

Units: millimeters
Tolerance: ±0.3

6. System Block Diagram

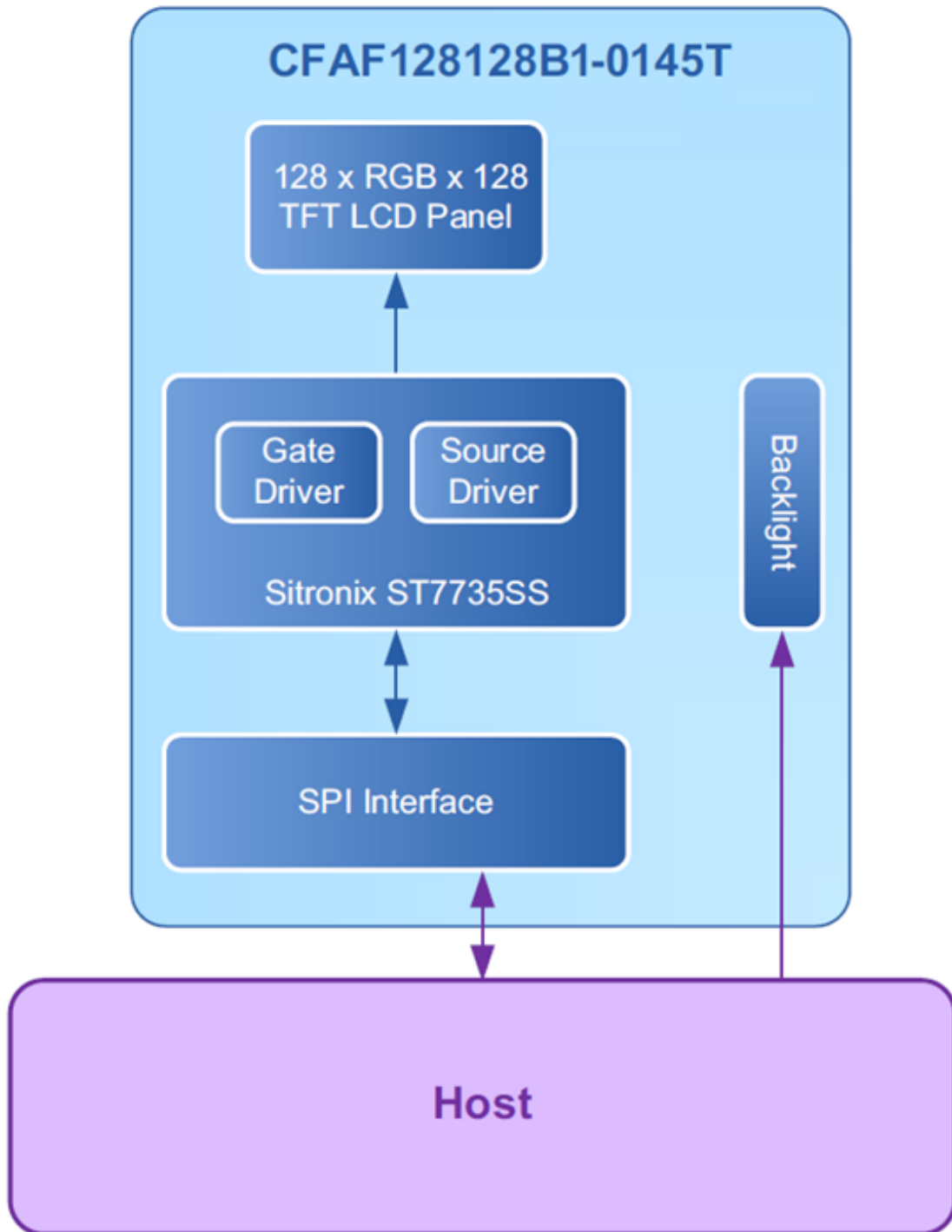

7. Interface Pin Function

Pin	Symbol	Function	
1	A (LED+)	Common supply pin for LED. "A" (anode) or "+" for LED backlight.	
2	K (LED-)	Individual supply pin for LED. "K" (cathode for German or original Greek spelling) or "-" of LED backlight.	
3	SPI4W / $\overline{\text{SPI3W}}$	$\overline{\text{SPI4W}} / \overline{\text{SPI3W}}$	
		0	3-wire, 9-bit SPI mode. The $\overline{\text{D/C}}$ pin is not used. The 9th SPI bit selects the data or command register.
		1	4-wire, 8-bit SPI mode. The $\overline{\text{D/C}}$ pin is used to select the data or command register.
4	V _{DD}	Digital Logic Supply and Input/Output Supply (3.0-3.6)	
5	GND	Ground. Must be connected to an external ground.	
6	$\overline{\text{CS}}$	Chip Select Input. Low: Controller chip is selected. Communications with host is possible. High: Controller chip is not selected. Host interface signals are ignored by the controller.	
7	$\overline{\text{RST}}$	Controller hardware reset pin, active low. On power on, drive $\overline{\text{RST}}$ low for at least 10 μ S. After $\overline{\text{RST}}$ is returned to high, wait 120mS for the internal reset operation to complete. Keep $\overline{\text{RST}}$ driven high for normal operation.	
8	SDA	Serial data, in or out (bi-directional)	
9	SCL	Serial Clock – rising edge.	
10	$\overline{\text{D/C}}$	In 4-wire, 8-bit SPI mode, the $\overline{\text{D/C}}$ pin is used to select the data or command register. 1 – High: Addresses the data register. 0 – Low: Addresses the command register. In 3-wire, 9-bit SPI mode, the $\overline{\text{D/C}}$ pin is not used. Connect to V _{LOGIC I/O} .	

8. Absolute Maximum Ratings

Parameter	Symbol	Min	Typ	Max	Unit	Notes
Supply Voltage for Logic	V _{DD}	-0.3	-	+4.6	V	(1)(2)(3)
Operating Temperature	T _{OPR}	-10	-	+60	°C	-
Storage Temperature	T _{STG}	-10	-	+60	°C	-

Note: These are stress ratings only. Extended exposure to the absolute maximum ratings listed above may affect device reliability or cause permanent damage. Functional operation should be restricted to the limits in the DC Characteristics table below.

9. Electrical Characteristics

T _A =25°C, V _{SS} =0V						
Item	Symbol	Condition	Min	Typ	Max	Unit
Supply Voltage for Logic	V _{DD}		3.0	3.3	3.6	V
Supply Current for LCM	I _{DD}	V _{DD} =3.3v	-	1.7	2.55	mA
Input High Voltage	V _{IH}	-	0.7 x V _{DD}	-	V _{DD}	V
Input Low Voltage	V _{IL}	-	GND	-	0.3 x V _{DD}	V

10. Optical Characteristics

Item	Symbol	Condition	Min	Typ	Max	Unit	Notes	
Transmittance	T	-	-	6.0	-	%	-	
Contrast Ratio	CR	Θ=0 Normal Viewing Angle	-	350	-	-	(1)(2)	
Response Time	T _{rise} +T _{fall}	-	-	25	-	ms	(1)(3)	
Red Chromaticity	x	θ=Φ=0° LED Backlight	0.5304	0.5804	0.6304	-	-	
	y		0.2934	0.3434	0.3934	-	-	
Green Chromaticity	x		0.2418	0.2918	0.3418	-	-	
	y		0.5265	0.5765	0.6265	-	-	
Blue Chromaticity	x		0.0918	0.1418	0.1918	-	-	
	y		0.0316	0.0816	0.1316	-	-	
White Chromaticity	x		0.1881	0.2381	0.2881	-	-	
	y		0.2293	0.2693	0.3293	-	-	
Viewing Angle (Horizontal)	θ _{x+}		CR ≥ 10	-	45	-	deg	-
	θ _{y-}			-	45	-	deg	-
Viewing Angle (Vertical)	θ _{x+}			-	35	-	deg	-
	θ _{y-}			-	15	-	deg	-
Viewing Direction	6 o'clock							

Notes:

- (1) Measuring Surrounding: Dark Room
- (2) Ambient Temperature: 25 ± 2°C
- (3) Warm Up Time: 30-Minutes

11. Timing Characteristics

11.1. Serial Interface Characteristics (3-line serial)

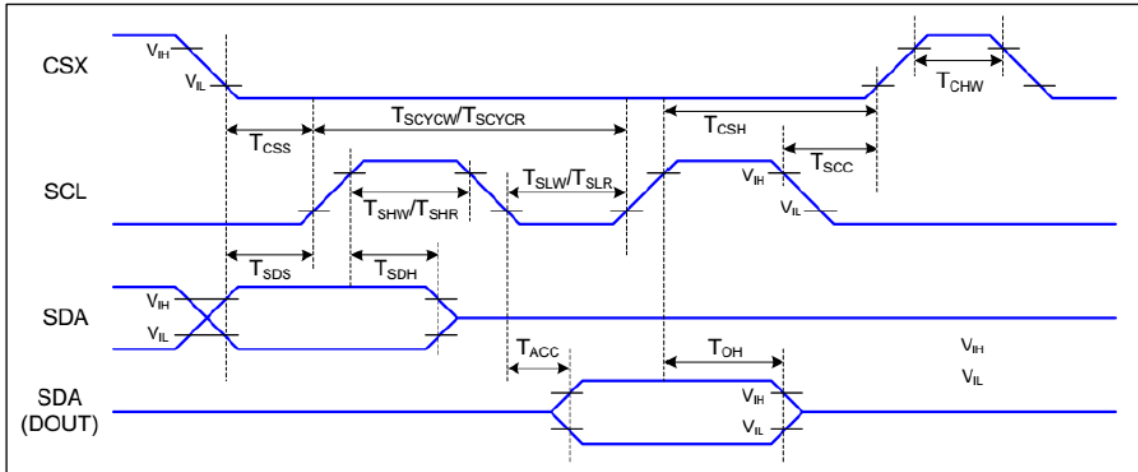

Ta=25 °C, VDDI=1.65~3.7V, VDD=2.5~4.8V

Signal	Symbol	Parameter	Min	Max	Unit	Description
CSX	TCSS	Chip Select Setup Time (Write)	15		ns	
	TCSH	Chip Select Hold Time (Write)	15		ns	
	TCSS	Chip Select Setup Time (Read)	60		ns	
	TSCC	Chip Select Hold Time (Read)	65		ns	
	TCHW	Chip Select "H" pulse width	40		ns	
SCL	TSCYCW	Serial Clock Cycle (Write)	66		ns	
	TSHW	SCL "H" Pulse Width (Write)	15		ns	
	TSLW	SCL "L" Pulse Width (Write)	15		ns	
	TSCYCR	Serial Clock Cycle (Read)	150		ns	
	TSHR	SCL "H" Pulse Width (Read)	60		ns	
	TSLR	SCL "L" Pulse Width (Read)	60		ns	
SDA (DIN) (DOUT)	TSDS	Data Setup Time	10		ns	For Maximum CL=30pF For Minimum CL=8pF
	TSDH	Data Hold Time	10		ns	
	TACC	Access Time	10	50	ns	
	TOH	Output Disable Time	15	50	ns	

11.2. Serial Interface Characteristics (4-line serial)

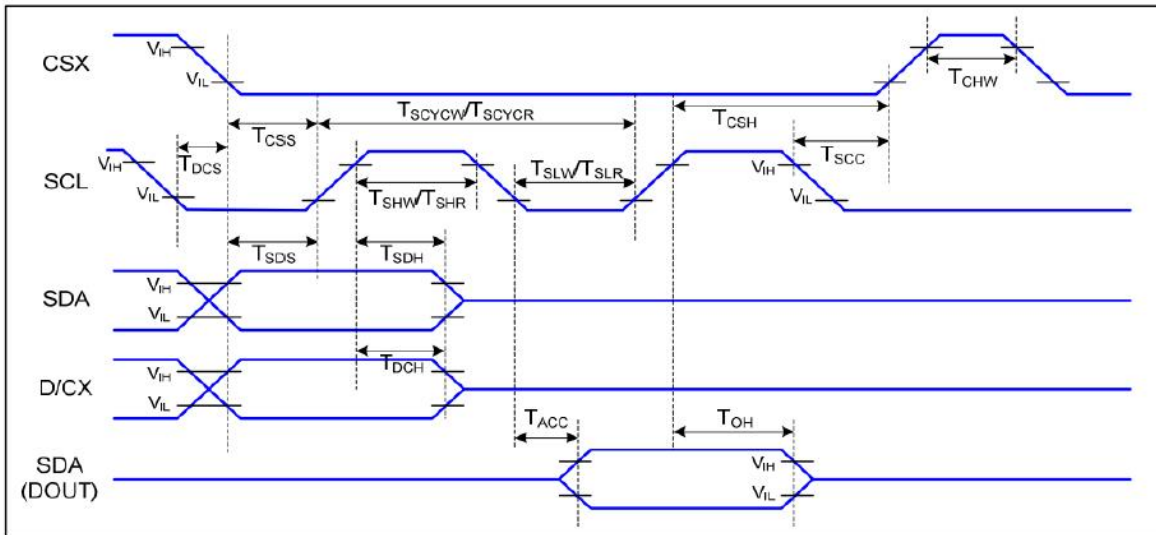

T_a=25 °C, V_{DDI}=1.65~3.7V, V_{DD}=2.5~4.8V

Signal	Symbol	Parameter	MIN	MAX	Unit	Description
CSX	T _{CSS}	Chip Select Setup Time (Write)	45		ns	
	T _{CCH}	Chip Select Hold Time (Write)	45		ns	
	T _{CSS}	Chip Select Setup Time (Read)	60		ns	
	T _{CCH}	Chip Select Hold Time (Read)	65		ns	
	T _{CHW}	Chip Select "H" Pulse Width	40		ns	
SCL	T _{SCYW}	Serial Clock Cycle (Write)	66		ns	-Write Command & Data Ram
	T _{SHW}	SCL "H" Pulse Width (Write)	15		ns	
	T _{SLW}	SCL "L" Pulse Width (Write)	15		ns	
	T _{SCYCR}	Serial Clock Cycle (Read)	150		ns	-Read Command & Data Ram
	T _{SHR}	SCL "H" Pulse Width (Read)	60		ns	
	T _{SLR}	SCL "L" Pulse Width (Read)	60		ns	
D/CX	T _{DCS}	D/CX Setup Time	10		ns	
	T _{DCH}	D/CX Hold Time	10		ns	
SDA (DIN) (DOUT)	T _{SDS}	Data Setup Time	10		ns	For Maximum CL=30pF For Minimum CL=8pF
	T _{SDH}	Data Hold Time	10		ns	
	T _{ACC}	Access Time	10	50	ns	
	T _{OH}	Output Disable Time	15	50	ns	

12. Backlight Characteristics

Item	Condition	Symbol	Min	Typ	Max	Unit
Supply Current	V=3.2v	I	-	20	-	mA
Supply Voltage	I _F =20mA	V	2.7	3.0	3.3	V
Luminous Intensity for LCM		-	120	180	-	cd/m ²
Uniformity for LCM		-	70	-	-	%
LED Lifetime		-	20K	-	-	Hours
Color	White					

Notes:

- (1) LED Lifetime is defined as the amount of time when the luminance has decayed to <50% of the initial value (20K hours is an estimate for reference only).

13. LCD Module Precautions

The precautions below should be followed when using LCD modules to help ensure personal safety, module performance, and compliance of environmental regulations.

13.1. Modules

- Avoid applying excessive shocks to module or making any alterations or modifications to it.
- Do not make extra holes on the printed circuit board, modify its shape or change the components of LCD display module.
- Do not disassemble the LCD display module.
- Do not operate the LCD display module above the absolute maximum rating.
- Do not drop, bend or twist the LCD display module.
- Do not solder. Use only an appropriate ZIF connector designed for FPC.
- ZIF connector should have gold flash contacts to maximize reliability/
- Store in an anti-static electricity container and clean environment.
- Crystalfontz may change passive components -- resistors, capacitors and other passive components may have different appearance and color due to different suppliers.
- Crystalfontz may change the flex PCB revision. An appropriate PCN will be issued if there is change to the form, fit or function. You can subscribe to PCNs on the module's web page.

13.2. Handling Precautions

- Since the display panel is made of glass, do not apply mechanical impacts or drop it.
- If the display panel is accidentally broken, and the internal organic substance leaks out, be careful not to inhale or touch the organic substance.
- If pressure is applied to the display surface or its neighborhood of the LCD display module, the cell structure may be damaged, so be careful not to apply pressure to these sections.
- The polarizer covering the surface of the LCD display module is soft and can be easily scratched. Please be careful when handling the LCD display module.
- Do not use any solvents (even water) to clean the LCD's polarizer. Using a cloth to rub the polarizer can cause small scratches that may reduce performance.
- If you need to clean the LCD's front surface, you can carefully apply and remove normal office tape. The contaminates will adhere to the tape and be removed from the LCD's polarizer.
- Ensure that your mounting secures the LCD and protects it from mechanical stresses
- The LCD module is sensitive to ESD. Treat the LCD module as you would a bare IC. Use appropriate ESD precautions when handling.
- Observe humidity limits. Do not operate the LCD if there is condensation.
- Do not make sharp bends in the FPC (Flexible Printed Circuit). Observe the following diagram:

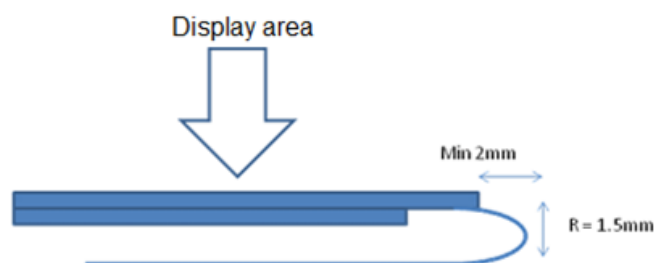

- Dispose of this module -- and any electronics -- properly. Do not place in the normal trash. Check with your local disposal company for procedures to recycle or dispose of electronics.