



CFAF240320A0-024SN-A1-1 DATASHEET



CFAF240320A0-024SN-A1-1

Datasheet Revision A0

Datasheet Release Date 2021-01-25

Crystalfontz America, Inc.

12412 East Saltese Avenue
Spokane Valley, WA 99216-0357
Phone: 888-206-9720
Fax: 509-892-1203
Email: support@crystalfontz.com
URL: www.crystalfontz.com

CONTENTS

1. General Information	3
2. Module Description	4
3. Features	4
3.1. Module Features.....	4
3.2. EVE Graphics Accelerator Features	4
4. Mechanical Data	4
5. Mechanical Drawing.....	5
6. Module Details	6
6.1. General Information.....	6
6.2. Embedded Video Engine Documentation / Resources	6
6.3. PCB Jumpers	6
6.4. Embedded Video Engine Programmer’s Model	7
6.5. Interface Pin Function.....	8
6.6. Absolute Maximum Ratings.....	9
6.7. Electrical Characteristics	9
6.8. Backlight Characteristics	9
6.9. Optical Characteristics.....	9
7. Getting Started	10
7.1. Getting started with the CFAF240320A0-024SN-A1-2 kit.....	10
7.2. Getting started with the CFAF240320A0-024SN-A1-1and a Windows PC.....	10
7.3. Getting started with CFAF240320A0-024SN-A1-1 and a custom PCB	11
7.4. Example Connection Diagrams	12
.....	13
7.5. ZIF Connector Use With Flat-Flex-Cable (FFC).....	14
8. Care and Handling Precautions	14
8.1. ESD (Electrostatic Discharge)	14
8.2. Design and Mounting.....	14
8.3. Mechanical Shock, Impact, Torque, or Tension	14
8.4. LCD Panel Breakage	14
8.5. Cleaning	14
8.6. Operation	15
8.7. Storage and Recycling	15



1. General Information

Datasheet Revision History

Datasheet Release: **2021-01-25**
Datasheet for the CFAF240320A0-024SN-A1-1 TFT graphic display module

Product Change Notifications

You can check for or subscribe to [Part Change Notices](#) for this display module on our website.

Variations

Slight variations between lots are normal (e.g., contrast, color, or intensity).

Volatility

This display module has volatile memory.

Disclaimer

Certain applications using CrystalFontz America, Inc. products may involve potential risks of death, personal injury, or severe property or environmental damage ("Critical Applications"). CRYSTALFONTZ AMERICA, INC. PRODUCTS ARE NOT DESIGNED, INTENDED, AUTHORIZED, OR WARRANTED TO BE SUITABLE FOR USE IN LIFE-SUPPORT APPLICATIONS, DEVICES OR SYSTEMS OR OTHER CRITICAL APPLICATIONS. Inclusion of CrystalFontz America, Inc. products in such applications is understood to be fully at the risk of the customer. In order to minimize risks associated with customer applications, adequate design and operating safeguards should be provided by the customer to minimize inherent or procedural hazard. Please contact us if you have any questions concerning potential risk applications.

CrystalFontz America, Inc. assumes no liability for applications assistance, customer product design, software performance, or infringements of patents or services described herein. Nor does CrystalFontz America, Inc. warrant or represent that any license, either express or implied, is granted under any patent right, copyright, or other intellectual property right of CrystalFontz America, Inc. covering or relating to any combination, machine, or process in which our products or services might be or are used.

All specifications in datasheets on our website are, to the best of our knowledge, accurate but not guaranteed. Corrections to specifications are made as any inaccuracies are discovered.

Company and product names mentioned in this publication are trademarks or registered trademarks of their respective owners.

Copyright © 2021 by CrystalFontz America, Inc., 12412 East Saltese Avenue, Spokane Valley, WA 99216 U.S.A.

2. Module Description

This full color IPS TFT graphic display module has a stunning 262k color span and bright white LED backlight. The display is mounted on a carrier board with an FTDI FT811 EVE graphics accelerator for both high-performance accelerated graphics and easy design integration.

3. Features

3.1. Module Features

- 240*320 Dot Matrix
- Sunlight readable LED backlight
- Wide viewing angles in all directions
- SPI single or Quad host interface
- Compact 30-pin, 0.5mm ZIF host connection
- 4 x 2-56 threaded mounting standoffs for simple integration
- Compact footprint
- Single 3.3v power supply

3.2. EVE Graphics Accelerator Features

- Support multiple widgets for simplified design implementation
- User interface design software (PC) simplifies the design process
- Enhanced sketch processing
- Anti-aliasing of primitive displayed objects for higher-quality graphics
- Assorted graphical effects such as alpha-blending, shadows, transitions, wipes, etc.
- Programmable interrupt controller provides interrupts to host MCU
- Support playback of motion-JPEG encoded AVI videos
- Mono audio channel output with wave playback and built-in sound synthesizer
- PWM output for display backlight dimming control

4. Mechanical Data

Item	Specification (mm)	Specification (inch, reference)
Overall Width and Height	42 (W) x 59 (H) x 6.69 (D)	1.65 (W) x 2.32 (H) x 0.26 (D)
Active Area	36.72 (W) x 48.96 (H)	1.45 (W) x 1.96 (H)
Dot Pitch	0.153 (W) x 0.153 (H)	0.006 (W) x 0.006 (H)
Weight (Typical)	22.3 grams	0.79 ounces

5. Mechanical Drawing

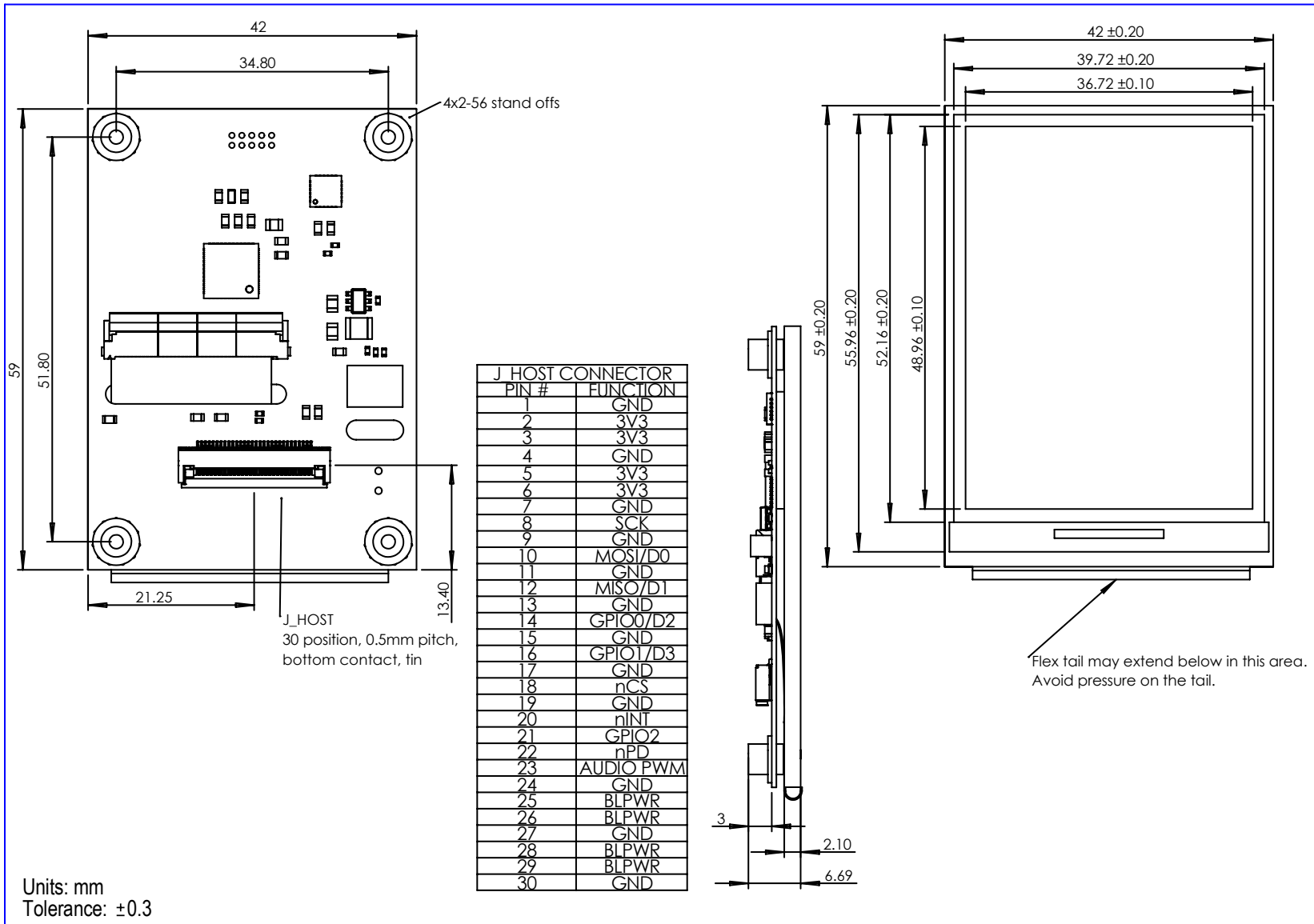

Units: mm
Tolerance: ±0.3

 <p>CrystalFontz ©2021 CrystalFontz America, Inc.</p>	Part Number:	Date:	Filename:	Revision:
	CFAF240320A0-024SN-A1-1	2021-01-18	CFAF240320A0-024SN-A1-1 mm.pdf	v1.0
		Web:	www.crystalfontz.com/product/CFAF240320A0024SNA11	Sheet:
				1 of 1

6. Module Details

6.1. General Information

The CFAF240320A0-024SN-A1-1 is a high-brightness, sunlight readable, TFT display module based around a FTDI/BridgeTek FT811 Embedded Video Engine (EVE).

All display, backlight control and audio features are controlled via the Embedded Video Engine which appears to the host MCU as a memory-mapped SPI device. The host MCU sends commands and data over the EVE SPI serial protocol.

For detailed BridgeTek datasheets and other development information, see the Embedded Video Engine Documentation / Resources section below.

6.2. Embedded Video Engine Documentation / Resources

- BridgeTek FT81x Datasheet: <https://brtchip.com/ft81x/>
- BridgeTek Application Notes: <https://brtchip.com/application-notes/>
- BridgeTek Screen Designer Software: <https://brtchip.com/eve-toolchains/>
- BridgeTek Forum: <http://www.brtcommunity.com/index.php?board=7.0>
- FTDI FT81x Datasheets: <https://www.ftdichip.com/Products/ICs/FT81X.html>
- FTDI Application Notes: <https://www.ftdichip.com/Support/Documents/AppNotes.htm>
- FTDI C232HM USB-SPI cable: <https://www.ftdichip.com/Products/Cables/USBMP SSE.htm>

6.3. PCB Jumpers

The PCB (CFA10109) has a jumpers that can be used to change the functionality of the display.

TEST: Shorting the TEST jumper when none of SCK, MOSI, MISO, and CS are shorted, causes the display to cycle through colors to demonstrate that the display functions.

BL_ON: Shorting the BL_ON jumper causes the backlight to be on whenever the module has power.

Shorting all jumpers (BL_ON can be in either state) will cause the NXP processor SPI signals to connect to the EVE. The NXP can be used to drive the display via the EVE FT811 chip.

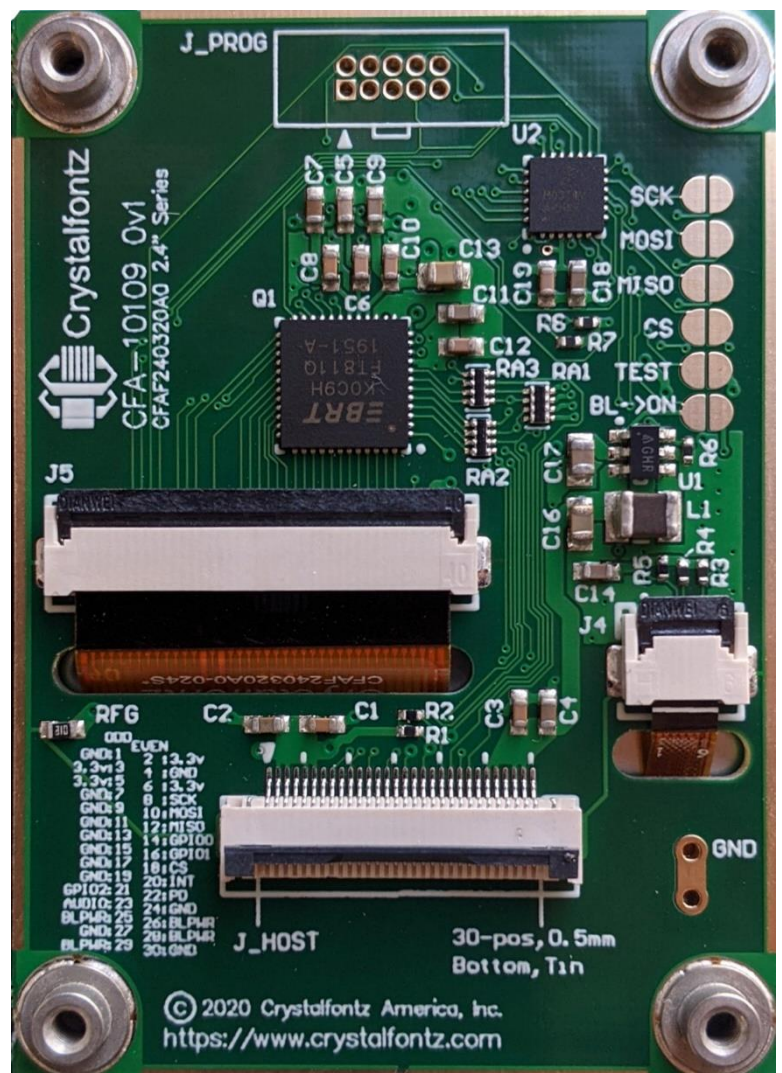



6.4. Embedded Video Engine Programmer's Model

The diagram below is a basic overview of the EVE programming model showing data flow paths to and from the SPI host interface to the memory and processing blocks of the embedded video engine.

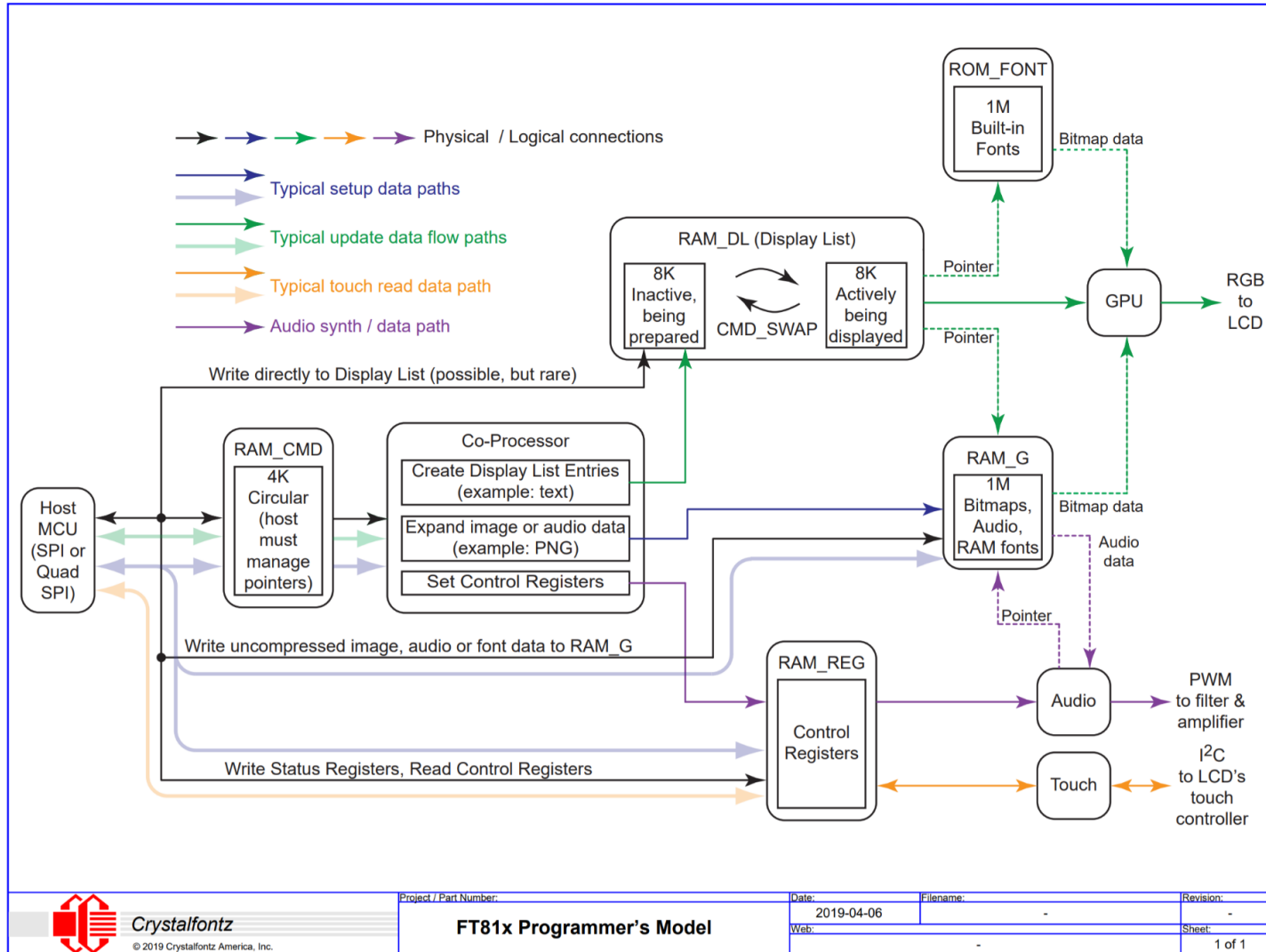

Project / Part Number:	Date:	Filename:	Revision:
FT81x Programmer's Model	2019-04-06	-	-
	Web:		Sheet:
			1 of 1



6.5. Interface Pin Function

Host data connection and power supply is achieved via a single 30 pin flat-cable connector (labeled J_HOST) on the rear of the module. Any 30 pin FFC-FPC ZIF cable with a 0.5mm pitch and bottom contacts will be compatible with this module.

J_HOST Connection			
Pin	Symbol	Signal Direction	Function
1	GND		Ground ⁽¹⁾
2	3V3		Logic Power Supply ⁽¹⁾
3	3V3		Logic Power Supply ⁽¹⁾
4	GND		Ground ⁽¹⁾
5	3V3		Logic Power Supply ⁽¹⁾
6	3V3		Logic Power Supply ⁽¹⁾
7	GND		Ground ⁽¹⁾
8	SCK	Input	SPI Clock
9	GND		Ground ⁽¹⁾
10	MOSI / D0	Input	SPI Single Mode: SPI MOSI SPI Dual/Quad Mode: SPI Data Line 0
11	GND		Ground ⁽¹⁾
12	MISO / D1	Output	SPI Single Mode: SPI MISO SPI Dual/Quad Mode: SPI Data Line 1
13	GND		Ground ⁽¹⁾
14	GPIO0 / D2	Input / Output	SPI Single/Dual Mode: General Purpose IO0 SPI Quad Mode: SPI Data Line 2
15	GND		Ground ⁽¹⁾
16	GPIO1 / D3	Input / Output	SPI Single/Dual Mode: General Purpose IO1 SPI Quad Mode: SPI Data Line 3
17	GND		Ground ⁽¹⁾
18	nCS	Input	SPI Slave Chip-Select
19	GND		Ground ⁽¹⁾
20	nINT	Output	Interrupt to Host
21	GPIO2		General purpose IO2
22	nPD	Input	Chip Power Down Mode
23	AUDIO PWM	Output	Audio PWM
24	GND		Ground ⁽¹⁾
25	BLPWR		Backlight Power Supply ⁽¹⁾
26	BLPWR		Backlight Power Supply ⁽¹⁾
27	GND		Ground ⁽¹⁾
28	BLPWR		Backlight Power Supply ⁽¹⁾
29	BLPWR		Backlight Power Supply ⁽¹⁾
30	GND		Ground ⁽¹⁾

Notes:

1. It is recommended that these pins are all connected to their respective power source. Not doing so may produce unpredictable results or damage the display module.

6.6. Absolute Maximum Ratings

Parameter	Symbol	Min	Max	Unit
Logic Power Supply	3V3	0.0	4.0	V
Backlight Power Supply	BLPWR	0.0	6.0	V
Operating Temperature	T _{OP}	-20	+70	°C
Storage Temperature	T _{ST}	-30	+80	°C

Notes:

- These are stress ratings only. Extended exposure to the absolute maximum ratings listed above may affect device reliability or cause permanent damage.
- Temp. ≤60°C, 90% RH Maximum Temp. >60°C Absolute humidity < 90% RH at 60°C

6.7. Electrical Characteristics

Item	Symbol	Min	Typ	Max	Unit
Logic Power Supply	3V3	2.97	3.30	3.63	V
Input Logic High	V _{IH}	2.0	-	3V3	V
Input Logic Low	V _{IL}	0	-	0.8	V
Logic Supply Current	I3V3	--	54	70	mA

6.8. Backlight Characteristics

Item	Symbol	Conditions	Min	Typ	Max	Unit
Supply Voltage	BLPWR		2.7	3.3	5.5	V
Supply Current	IBLPWR	BLPWR=3.3V	-	106	166	mA
LED Lifetime		at 100% brightness	-	20000	-	hours

6.9. Optical Characteristics

Item	Symbol	Condition	Min	Typ	Max	Unit	
Response Time	T _r + T _f	25°C	-	35	-	ms	
Contrast Ratio	(CR)	θ=0°	-	800	-	-	
Chromaticity	Red _x	Backlight On	0.589	0.639	0.689	-	
	Red _y		0.285	0.335	0.385	-	
	Green _x		0.290	0.340	0.390	-	
	Green _y		0.849	0.599	0.640	-	
	Blue _x		0.093	0.143	0.193	-	
	Blue _y		0.038	0.088	0.138	-	
	White _x		0.265	0.315	0.365	-	
	White _y		0.288	0.338	0.388	-	
Viewing Angle	Horizontal	CR ≥ 10	θ _L	-	80	-	Degree
			θ _R	-	80	-	
	Vertical		θ _T	-	80	-	
			θ _B	-	80	-	
Luminance	L	-	700	850	-	cd/m ²	

7. Getting Started

7.1. Getting started with the CFAF240320A0-024SN-A1-2 kit

Components:

- Crystalfontz CFAF240320A0-024SN-A1-1 [module](#)
- Crystalfontz [CFA10098](#) EVE adapter board
- Appropriate flat-flex-cable (6" [WR-FFC-Y50](#) & 12" [WR-FFC-Y51](#))
- 0.1" female-to-female jumper wires (Crystalfontz [WR-JMP-Y40](#))
- Seeeduino v4.2 set to 3.3 V (Crystalfontz [CFAPN15062](#))
- USB Cable (Crystalfontz [WR-USB-Y27](#))
- A PC with [Arduino IDE](#) (or equivalent) installed and at least one USB port

Hardware Procedure:

- Connect the components per the Example Connection Diagrams in Section 7.4
- Ensure the Seeeduino is set to 3v3
- Connect the USB cable to a PC

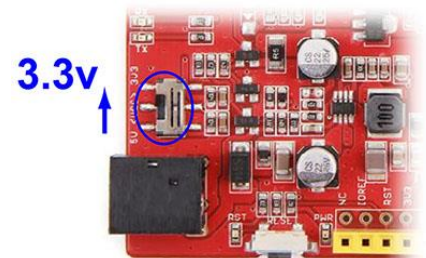

Firmware Procedure:

- Download and install [Arduino IDE](#) software
- Download the sketch available on [the product page](#) or [on GitHub](#), and open it in the Arduino IDE.
- Build and upload the sketch to the Seeeduino

7.2. Getting started with the CFAF240320A0-024SN-A1-1 and a Windows PC

Components:

- Crystalfontz CFAF240320A0-024SN-A1-1 [display module](#)
- Crystalfontz [CFA10098](#) EVE adapter board
- Appropriate flat-flex-cable (6" [WR-FFC-Y50](#) & 12" [WR-FFC-Y51](#))
- FTDI [C232HM-DDHSL-0](#) USB-to-SPI cable
- Bench supply set to 3.3v, rated for at least 1000mA

Hardware Procedure:

- Connect the CFA10098 to the CFAF240320A0-024SN-A1-1 using the FFC (see section 7.5 below)
- Connect the USB-to-SPI cable to the carrier board of the CFAF240320A0-024SN-A1-1
- Connect 3.3v from a bench supply (rated for at least 1000mA) to the CFA10098
- Connect the USB to SPI cable to a Windows PC

Software Procedure:

- Download and install the FTDI PC demonstration application from [the Bridgetek website](#).
- Download, open, build and run the example EVE application [available on GitHub](#).
In order to modify and compile the FTDI PC demonstration program, requires Visual Studio. There is a free version but it may require registering with Microsoft.

7.3. Getting started with CFAF240320A0-024SN-A1-1 and a custom PCB

Components:

- Crystalfontz CFAF240320A0-024SN-A1-1 [display module](#)
- ZIF connector: 30-position, 0,5mm pitch, tin contact mounted to the custom PCB ([CS050Y30T-B0](#))
- Flat-flex-cable: 30-position, 0,5mm pitch, tin contact (6" [WR-FFC-Y50](#) & 12" [WR-FFC-Y51](#))

Procedure:

- Connect the FFC to the ZIF connector on the PCB
- Connect the FFC to the ZIF connector on the CFAF240320A0-024SN-A1-1(see the 7.5 below)
Note that the power supply must be able to supply enough current to drive the backlight.



7.4. Example Connection Diagrams

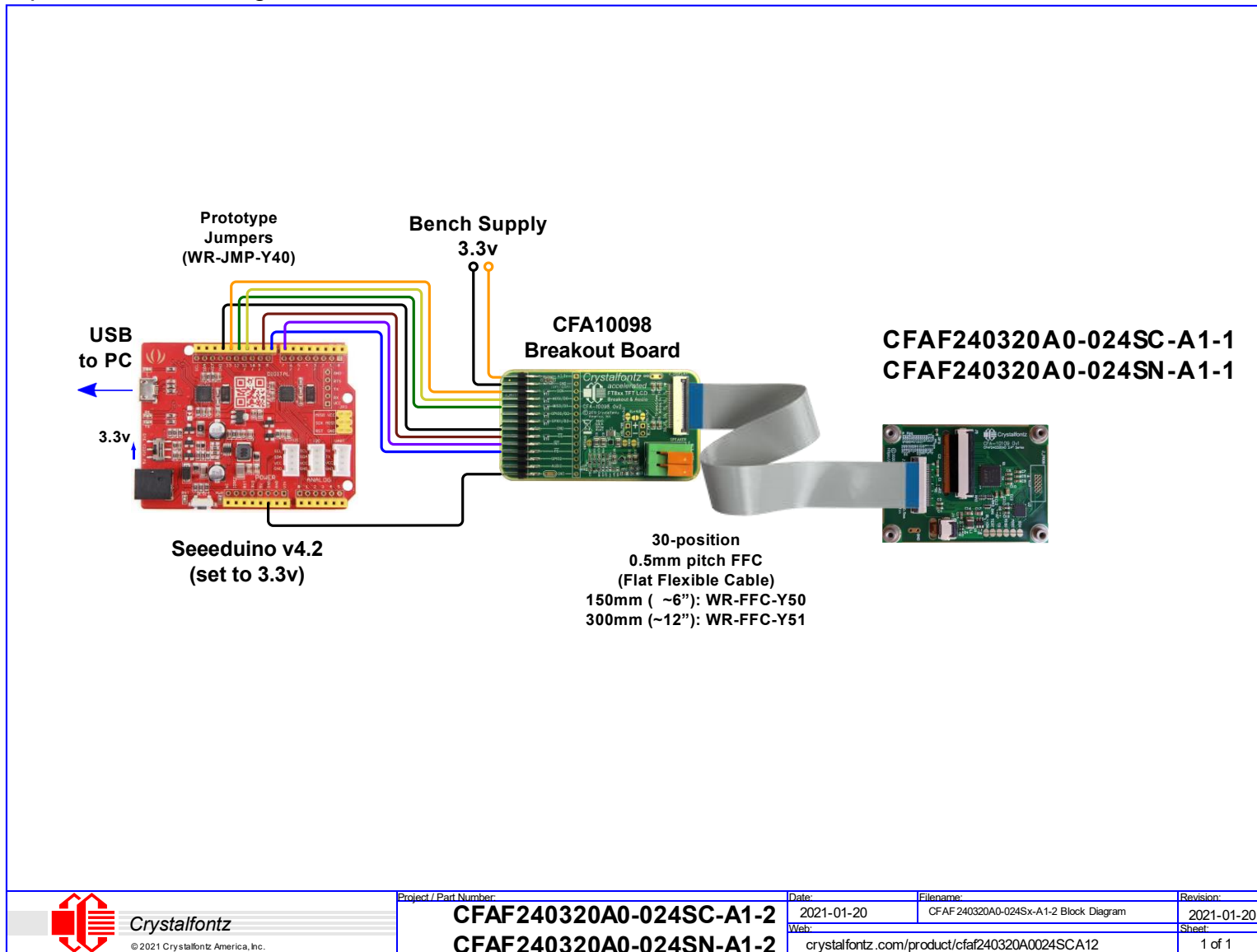

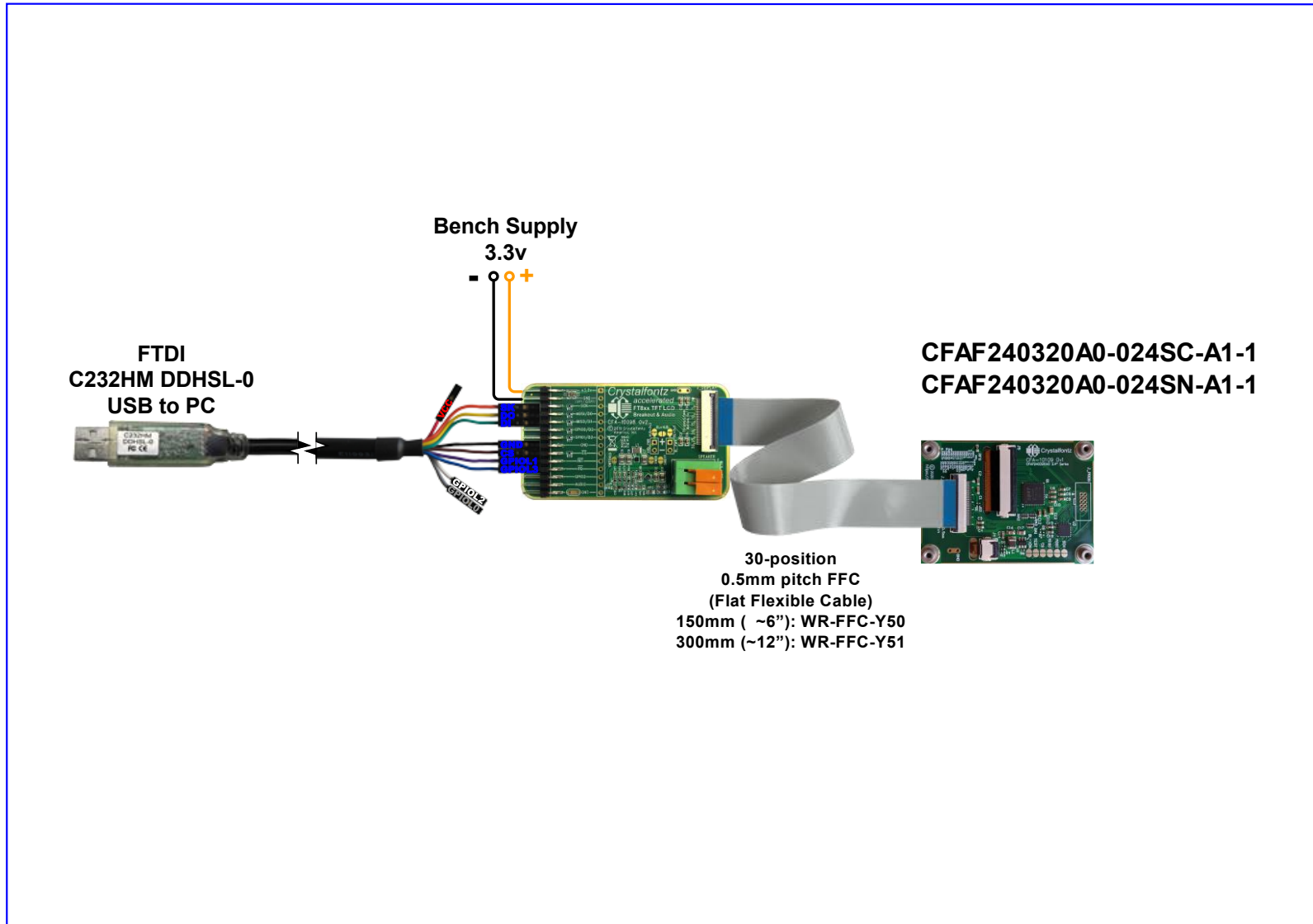

 CrystalFontz © 2021 CrystalFontz America, Inc.	Project / Part Number	Date	Filename	Revision
	CFAF240320A0-024SC-A1-1 CFAF240320A0-024SN-A1-1	2021-01-20	CFAF240320A0-024Sx-A1-1 Block Diagram	2021-01-20
		Web:		Sheet:
		crystalfontz.com/product/cfaf240320A0024SCA12		1 of 1



7.5. ZIF Connector Use With Flat-Flex-Cable (FFC)

Please take note of the orientation of the flat-flex-cable, and use of the locking clip in the following photos.

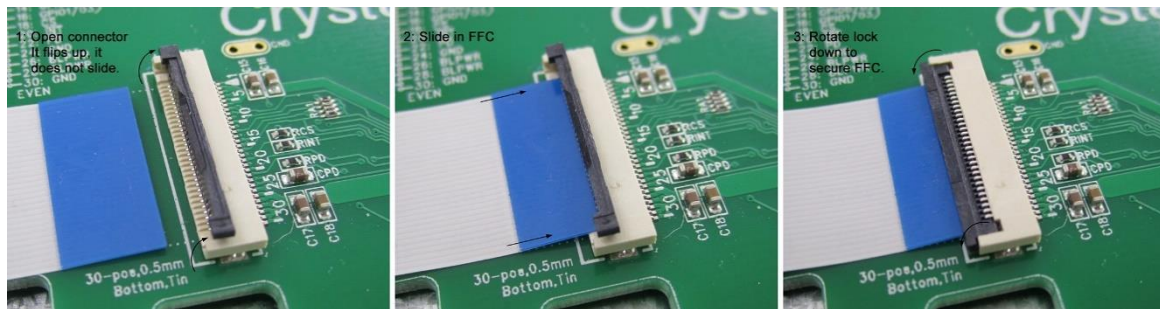

8. Care and Handling Precautions

For optimum operation of the **Error! Unknown document property name.** is and to prolong its life, please follow the precautions described below.

8.1. ESD (Electrostatic Discharge)

If present, the USB D+ & D- lines have enhanced ESD protection following industry standard USB2 practice.

The remainder of this circuitry is industry standard CMOS logic and susceptible to ESD damage. Please use industry standard antistatic precautions as you would for any other static sensitive devices such as expansion cards, motherboards, or integrated circuits. Ground your body, work surfaces, and equipment.

8.2. Design and Mounting

- The exposed surface of the display is either a touch-sensitive panel, or a polarizer laminated on top of the glass. To protect the surface from damage, the module ships with a protective film over the display. Please peel off the protective film slowly. Peeling off the protective film abruptly may generate static electricity.
- If the display does not have a touch-sensitive panel, to protect the soft plastic polarizer from damage, place a transparent plate (for example, acrylic, polycarbonate or glass), in front of the module, leaving a small gap between the plate and the display surface.
- Do not disassemble or modify the module.
- Do not modify the six tabs of the metal bezel or make connections to them.
- Do not reverse polarity to the power supply connections. Reversing polarity will immediately ruin the module.

8.3. Mechanical Shock, Impact, Torque, or Tension

- Do not expose the module to strong mechanical shock, impact, torque, or tension.
- Do not drop, toss, bend, or twist the module.
- Do not place weight or pressure on the module.

8.4. LCD Panel Breakage

- If the LCD panel breaks, be careful to not get the liquid crystal fluid in your mouth or eyes.
- If the liquid crystal fluid touches your skin, clothes, or work surface, wash it off immediately using warm soapy water.

8.5. Cleaning

- The display surface can easily be scratched or become hazy, so use extra care when you clean it.



- Do not clean the display surface with liquids.
- If the display surface becomes dusty, carefully blow it off with clean, dry, oil-free compressed air.
- Use the removable protective film to remove smudges (for example, fingerprints), and any foreign matter. If you no longer have the protective film, use standard transparent office tape (for example, Scotch® brand “Crystal Clear Tape”).
- If the above methods are not adequate, gently wipe using a very soft, clean, dry, lint free cloth (such as a microfiber towelette).
- Contact with moisture may permanently spot or stain the polarizer.

8.6. Operation

- Protect the module from ESD and power supply transients.
- Observe the operating temperature limitations: a minimum of -20°C to a maximum of +70°C with minimal fluctuation. Operation outside of these limits may shorten life and/or harm display.
- At lower temperatures of this range, response time is delayed.
- At higher temperatures of this range, display becomes dark (you may need to adjust the contrast).
- Operate away from dust, moisture, and direct sunlight.
- Adjust backlight brightness so the display is readable, but not too bright.
- Dim or turn off the backlight during periods of inactivity to conserve the backlight lifetime.

8.7. Storage and Recycling

- Store in an ESD-approved container away from dust, moisture, and direct sunlight.
- Observe the storage temperature limitations: -30°C minimum, +80°C maximum with minimal fluctuation. Rapid temperature changes can cause moisture to form, resulting in permanent damage.
- Do not allow weight to be placed on the module while in storage.
- Please recycle your outdated Crystalfontz modules at an approved facility.