



Crystalfontz America, Incorporated

GRAPHIC OLED MODULE SPECIFICATIONS



Crystalfontz Model Number	CFAL12822A-Y-B1
Hardware Version	Revision v1.1, August 2010
Data Sheet Version	Revision 2.1, January 2011
Product Pages	www.crystalfontz.com/product/CFAL12822AYB1.html

Crystalfontz America, Incorporated

12412 East Saltese Avenue
Spokane Valley, WA 99216-0357

Phone: 888-206-9720

Fax: 509-892-1203

Email: techinfo@crystalfontz.com

URL: www.crystalfontz.com



REVISION HISTORY

HARDWARE	
2010/08/23	<p>Hardware version: v1.1 (See PCN 10284. Version number has not changed.</p> <p>Since last hardware revision:</p> <ul style="list-style-type: none">● The OLED panel was reduced from “65 mm x 23.5 mm” to “63.3 mm x 20.8 mm”.● A carrier was added to bring the module overall dimensions to “65.00 mm x 23.5 mm”. See the carrier in Module Outline Drawings (Pg. 11).● Improvements in the organic material increased efficiency.<ul style="list-style-type: none">- The typical driving voltage changed from “+14v” to “+12v”.- The typical brightness (luminosity) increased from “80 cd/m²” to “100 cd/m²”.- For the CFAL12822A series, lifetime increased from “10,000 hours” to “20,000 hours” at 50% brightness.● The shape but not length or pitch of the FFC tail changed.
2008/10/01	<p>Hardware version: v1.1 Factory location changed. The module has not changed.</p>
2009/04/27	<p>Hardware version: vA New module.</p>

DATA SHEET	
2011/01/13	<p>Current Data Sheet version: v2.1</p> <p>Since last Data Sheet (v2.0), the following Data Sheet changes were made:</p> <ul style="list-style-type: none">● Wherever listed, including in the hardware revision information for 2010/08/23 listed above, corrected carrier width from “64.80” to “65.00” mm. Physical module has not changed.● In Details of Interface Pin Function (Pg. 18),<ul style="list-style-type: none">- Pin 10 description, deleted “<i>SPI (serial) mode: Pin acts as SA0 for slave address selection.</i>” This information was not correct.- Pin 16 description, added note “<i>When using SPI interface, DB2 should be left open. DB3-DB7 should be tied to GND (low).</i>”



DATA SHEET (Continued)	
2010/09/17	<p>Data Sheet version: v2.0 Since last Data Sheet (v1.1), the following Data Sheet changes are based on the improved hardware version v1.1. See PCN 10284.</p> <ul style="list-style-type: none">● Wherever listed, changed<ul style="list-style-type: none">- Dimension for overall module width with FFC unfolded from "65.00" to "64.80" millimeters.- Depth dimension from "2.25" to "2.45" millimeters maximum. This is a correction. Module has not changed.- Bend radius from ">R 1.28 mm" to ">5.00 mm".● In Physical Characteristics, added Mechanical Vibration specifications.● Revised Module Outline Drawings to include new carrier board.● In Absolute Maximum Ratings changed Driver Supply Voltage<ul style="list-style-type: none">- <i>Minimum</i> from "+12v" to "+11.5v".- <i>Maximum</i> from "+16v" to "+12.5v".● In DC Characteristics, changed OLED Driver Supply Voltage<ul style="list-style-type: none">- <i>Minimum</i> from "+12v" to "+11.5v".- <i>Typical</i> from "+14v" to "+12v".- <i>Maximum</i> from "+16v" to "+12.5v".● In Optical Characteristics, improved typical Luminous Intensity from "80 cd/m²" to "100 cd/m²".● In Module Reliability,<ul style="list-style-type: none">- Increased lifetime estimate from "10,000 hours >50% of initial brightness at typical brightness for a new module" to "Brightness will be >50% of a new module's initial brightness for at least 20,000 hours of operation."- Added description of test conditions for lifetime specification.● Minor change was made in the APPENDIX B: SAMPLE CODE.● Added more terms to APPENDIX C: OLED MODULE TERMS AND SYMBOLS.● Throughout Data Sheet, made minor text, format, and illustration changes to improve understanding.● After the Data Sheet, added <i>CFA10009 User Guide</i> for the optional CrystalFontz CFA-10009 Demonstration PCB.
2009/12/21	<p>Data Sheet version: v1.1 Since last Data Sheet (v1.0):</p> <ul style="list-style-type: none">● Wherever listed, corrected specification of overall module depth in inches. Module dimensions did not change.<ul style="list-style-type: none">- Changed maximum from "0.89" to "0.09" inches.- Changed nominal from "0.85" to "0.08" inches.● Fixed broken cross-reference for Absolute Maximum Ratings.● Corrected mention of "TFT" to "OLED" in APPENDIX C: OLED MODULE TERMS AND SYMBOLS.



DATA SHEET (Continued)	
2009/11/12	<p>Data Sheet version: v1.0 Since last Data Sheet (no version number, unmarked Preliminary):</p> <ul style="list-style-type: none">● Moved specifications into standard Graphic OLED template.● In Physical Characteristics (previously “General Specifications”):<ul style="list-style-type: none">- Corrected “Viewing Area” <i>height</i> from “13.7” to “13.85” millimeters. Viewing Area is unchanged and was correct in the 2009/04/13 Contour Drawing of the Preliminary version.- Changed “Module Dimension” <i>height</i> from “23.5” millimeters (which is OLED panel height) to “33.52” (OLED panel with FFC fold) and “59.50” (OLED panel with FFC unfolded).- Expanded “Module Dimension” <i>depth</i> description from “2.15” to <i>nominal depth</i> “2.15” and <i>maximum depth</i> “2.25” millimeters.- Added specifications for “Diagonal”, “FFC Bend Radius”, “Module Connector Pitch”, and “Weight”.● Deleted “Contour Drawing” date 2008/12/29 on page 7. This was an outdated duplicate of a second Contour Drawing date 2009/04/13 on page 8. Descriptions in second Contour Drawing were updated. No dimensions changed. See Module Outline Drawings.● In Absolute Maximum Ratings:<ul style="list-style-type: none">- Changed V_{LOGIC} (Logic Supply Voltage) minimum from “-0.3v” to “2.4v”.- Added V_{PANEL} (Driver Supply Voltage) and Humidity specifications.● Expanded “Precautions in use of OLED Modules” with important information on design, hot bar soldering, and cleaning. See CARE AND HANDLING PRECAUTIONS.



DATA SHEET (Continued)	
2009/11/12	<ul style="list-style-type: none"> ● Clarified and expanded electrical characteristics. See DC Characteristics. Slight change in V_{IH} specification from “+2.4v” to “+2.64v”. ● In Details of Interface Pin Function, used CrystalFontz standard terms for signals and improved descriptions. ● Improved illustrations include adding: <ul style="list-style-type: none"> - More details in System Block Diagram. - Circuit example using Micrel MIC2290 for V_{PANEL} (see Circuit Example – Externally Supplied for Display). - Illustration to explain Power Up and Power Down Sequencing. - Photo with pins labeled (see Photo Reference for ZIF Connector Pin Functions). - Definition of Viewing Angle in Optical Characteristics. ● Also added these new sections: <ul style="list-style-type: none"> - MAIN FEATURES. - ESD (Electro-Static Discharge). - MODULE RELIABILITY AND LONGEVITY. - APPENDIX A: QUALITY ASSURANCE STANDARDS. - APPENDIX B: SAMPLE CODE - APPENDIX C: OLED MODULE TERMS AND SYMBOLS. - APPENDIX D: SOLOMON SYSTECH SSD1305 CONTROLLER SPECIFICATION SHEET. ● Deleted information that is repeated in the appended controller specifications. ● This module can be ordered as part of a CFA10009 demonstration board kit. The <i>CFA10009 User Guide</i> was added at the end of this Data Sheet.
2009/04/27	Data Sheet version: No version number (unmarked Preliminary) New Data Sheet.



The Fine Print

Certain applications using CrystalFontz America, Inc. products may involve potential risks of death, personal injury, or severe property or environmental damage ("Critical Applications"). CRYSTALFONTZ AMERICA, INC. PRODUCTS ARE NOT DESIGNED, INTENDED, AUTHORIZED, OR WARRANTED TO BE SUITABLE FOR USE IN LIFE-SUPPORT APPLICATIONS, DEVICES OR SYSTEMS OR OTHER CRITICAL APPLICATIONS. Inclusion of CrystalFontz America, Inc. products in such applications is understood to be fully at the risk of the customer. In order to minimize risks associated with customer applications, adequate design and operating safeguards should be provided by the customer to minimize inherent or procedural hazard. Please contact us if you have any questions concerning potential risk applications.

CrystalFontz America, Inc. assumes no liability for applications assistance, customer product design, software performance, or infringements of patents or services described herein. Nor does CrystalFontz America, Inc. warrant or represent that any license, either express or implied, is granted under any patent right, copyright, or other intellectual property right of CrystalFontz America, Inc. covering or relating to any combination, machine, or process in which our products or services might be or are used.

The information in this publication is deemed accurate but is not guaranteed.

Company and product names mentioned in this publication are trademarks or registered trademarks of their respective owners.

Copyright © 2011 by CrystalFontz America, Inc., 12412 East Saltese Avenue, Spokane Valley, WA 99216-0357 U.S.A.



CONTENTS

MAIN FEATURES	8
Demonstration and Evaluation Platform	8
Comparison to LCD (Liquid Crystal Display) Module	8
Features	8
Module Classification Information	9
MECHANICAL SPECIFICATIONS	9
Physical Characteristics	9
Module Outline Drawings	11
ELECTRICAL SPECIFICATIONS	14
System Block Diagram	14
Circuit Example – Externally Supplied for Display	15
Power Up and Power Down Sequencing	16
Absolute Maximum Ratings	16
DC Characteristics	17
Details of Interface Pin Function	18
Photo Reference for ZIF Connector Pin Functions	20
ESD (Electro-Static Discharge)	20
OPTICAL SPECIFICATIONS	21
Optical Characteristics	21
OLED CONTROLLER INTERFACE	22
MODULE RELIABILITY AND LONGEVITY	22
Module Reliability	22
Module Longevity (EOL / Replacement Policy)	22
CARE AND HANDLING PRECAUTIONS	23
APPENDIX A: QUALITY ASSURANCE STANDARDS	25
APPENDIX B: SAMPLE CODE	29
Sources For Driver Libraries	29
Sample Code	29
APPENDIX C: OLED MODULE TERMS AND SYMBOLS	32
APPENDIX D: SOLOMON SYSTECH SSD1305 CONTROLLER SPECIFICATION SHEET	37

LIST OF FIGURES

Figure 1. Module Outline Drawings (next 3 pages)	11
Figure 2. System Block Diagram	14
Figure 3. Circuit Example – External Supply for Display	15
Figure 4. Power Up and Power Down Sequencing	16
Figure 5. Back View of ZIF Connector Pins (Labeled)	20
Figure 6. CFAL12822A-Y-B1 has a 160° Viewing Angle	21
Figure 7. Limit Bend Radius of FFC	24



MAIN FEATURES

DEMONSTRATION AND EVALUATION PLATFORM

This module is available installed on a Crystalfontz CFA-10009 Demonstration PCB. The [DMO-L12822AYB1](#) kit has everything you need to easily demonstrate and experiment with the module. The kit can also be used as a reference for your designs.

COMPARISON TO LCD (LIQUID CRYSTAL DISPLAY) MODULE

The CFAL12822A-Y-B1 is a 128 x 22 dot matrix Organic Light-Emitting Diode (OLED) display module. The small size and ultrathin form factor of the CFAL12822A-Y-B1 makes it possible to use this OLED module in applications where it would be difficult or impossible to fit a traditional monochrome LCD module. Because of the low power requirements, the CFAL12822A-Y-B1 is suitable in battery powered portable devices such as remote controls and scientific meters (for example, temperature, sound, and gas detection).

Compared to most LCD modules, this OLED module has a quicker response time and an extremely wide viewing angle. At the low end of an STN LCD's temperature range, a module's contrast will typically be poor and the response time will be very slow. Unlike an STN LCD module, contrast does not diminish and response time is good at the lower end of an OLED module's operating temperature range, allowing it to operate in cold environments without a heater.

FEATURES

- 128 x 22 module consists of an OLED panel, a COG (Chip On Glass) driver IC, and an FFC (Flat Flexible Cable) that mates with a ZIF connector.
- Module Dimensions
 - Active Area is 2.36" diagonal, 58.85 (W) x 11.85 (H) millimeters (2.32" (W) x 0.47" (H)).
 - Overall module dimension with FFC unfolded is 65 (W) x 59.50 (H) x 2.45 maximum (D) mm (2.55" (W) x 2.34" (H) x 0.10" maximum (D)).
 - Overall module dimension without FFC is 65 (W) x 23.50 (H) x 2.45 maximum (D) mm (2.55" (W) x 0.93" (H) x 0.10" maximum (D)).
- Requires 3v for logic and a separate supply for V_{PANEL} .
- 8-bit parallel (8080 or 6800) interface or SPI Interface.
- Built-in Solomon Systech [SSD1305](#) or compatible controller.
- Emissive monochrome display. Displays yellow pixels on dark area or dark pixels on yellow area (if operating with display pixels reversed/inverted).
- CFAL12822A-Y-B1 mates with standard 0.5 mm 24-pin ZIF sockets such as [OR721CT-ND](#), [OR709CT-ND](#), and [OR877CT-ND](#) available from Digi-Key.
- Very high contrast ratio.
- Extremely wide viewing angle is $>160^\circ$.
- Wide temperature operation is -20°C to $+70^\circ\text{C}$.
- RoHS compliant.



MODULE CLASSIFICATION INFORMATION

CFA L 128 22 A - Y - B1
 ① ② ③ ④ ⑤ ⑥ ⑦

①	Brand	CrystalFontz America, Inc.
②	Display Type	L – OLED
③	Number of Pixels (Width)	128 pixels
④	Number of Pixels (Height)	22 pixels
⑤	Model Identifier	A
⑥	Display Color	Y – Yellow
⑦	Special Code	B1 – Manufacturer's code

MECHANICAL SPECIFICATIONS

PHYSICAL CHARACTERISTICS

Number of Pixels		
128 x 22 pixels = 2,816 pixels		
Pixel Detail	Width	Height
Pixel Size	0.43 mm	0.51 mm
Pixel Pitch	0.46 mm	0.54 mm

Module Depth		
	Maximum	Nominal
Millimeters	2.45	2.15
Inches	0.10"	0.08"

Viewing Area		
	Width	Height
Millimeters	60.85	13.85
Inches	2.40"	0.55"

Active Area		
Diagonal	Inches: 2.36"	
	Width	Height
Millimeters	58.85	11.85
Inches	2.32"	0.47"

Module Overall with FFC Unfolded		
	Width	Height
Millimeters	65.00	59.50
Inches	2.55"	2.34"

Module Overall without FFC (Carrier)		
	Width	Height
Millimeters	65.00	23.50
Inches	2.55"	0.93"



Other Physical Characteristics	
Module Connector Pitch	Standard 0.5mm 24-pin ZIF socket <i>The module's FFC mates with standard 0.5 mm 24-pin ZIF sockets such as OR721CT-ND, OR709CT-ND, and OR877CT-ND available from Digi-Key.</i>
FFC Bend Radius	>R5.00 mm
Weight	5 grams (typical)
Mechanical Vibration	Samples passed test with these conditions: Frequency: 5~50Hz,0.5G Scan rate: 1 octave per minute Time: 2 hours each axis Axis: X,Y, Z <i>The effect of vibrations or shock depends on how you mount the module. Test your completed product to ensure it meets your vibration and shock requirements. The specifications above are for a module that is not mounted.</i>



MODULE OUTLINE DRAWINGS

Figure 1. Module Outline Drawings (next 3 pages)

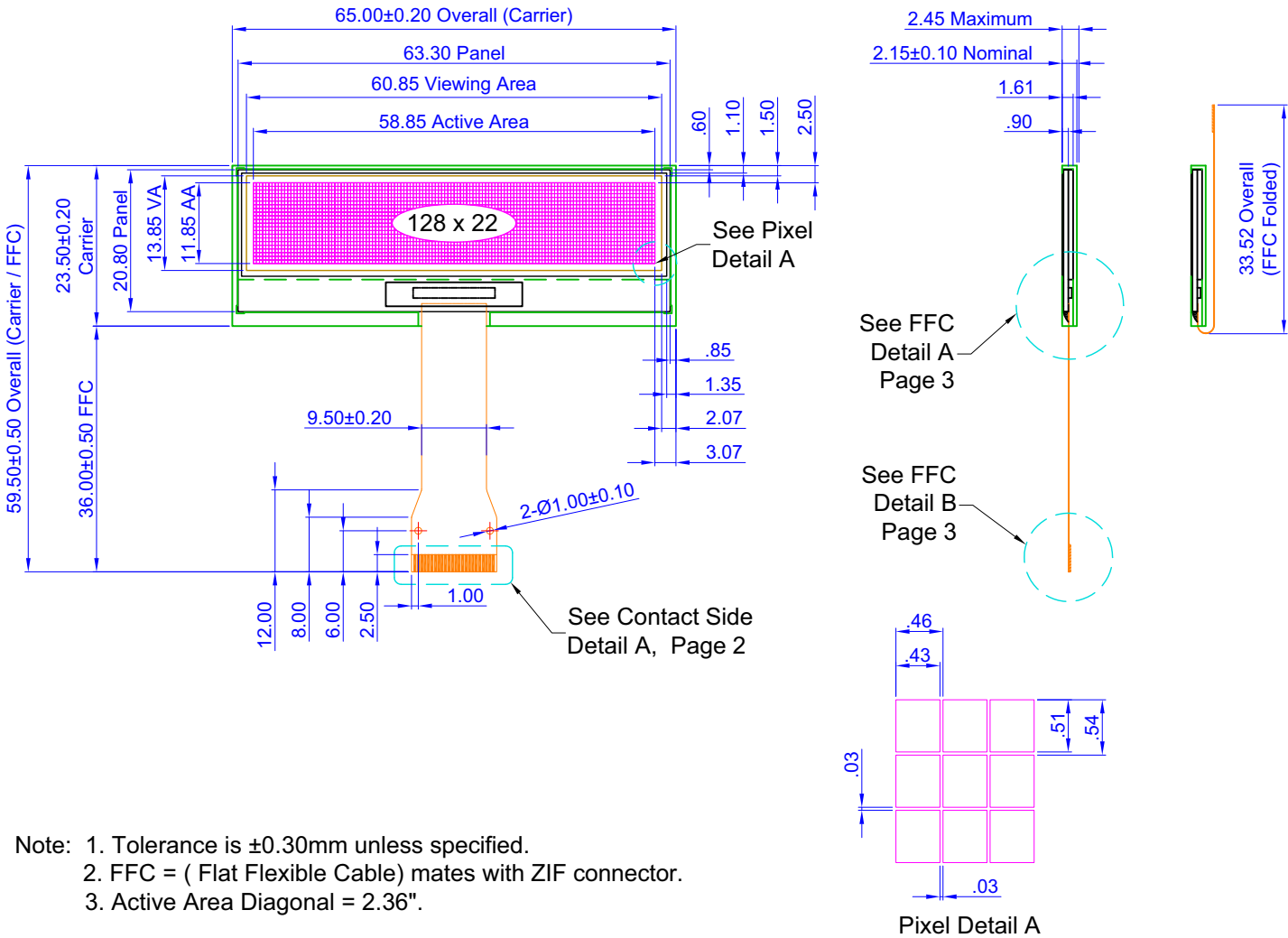

- Note: 1. Tolerance is ±0.30mm unless specified.
 2. FFC = (Flat Flexible Cable) mates with ZIF connector.
 3. Active Area Diagonal = 2.36".

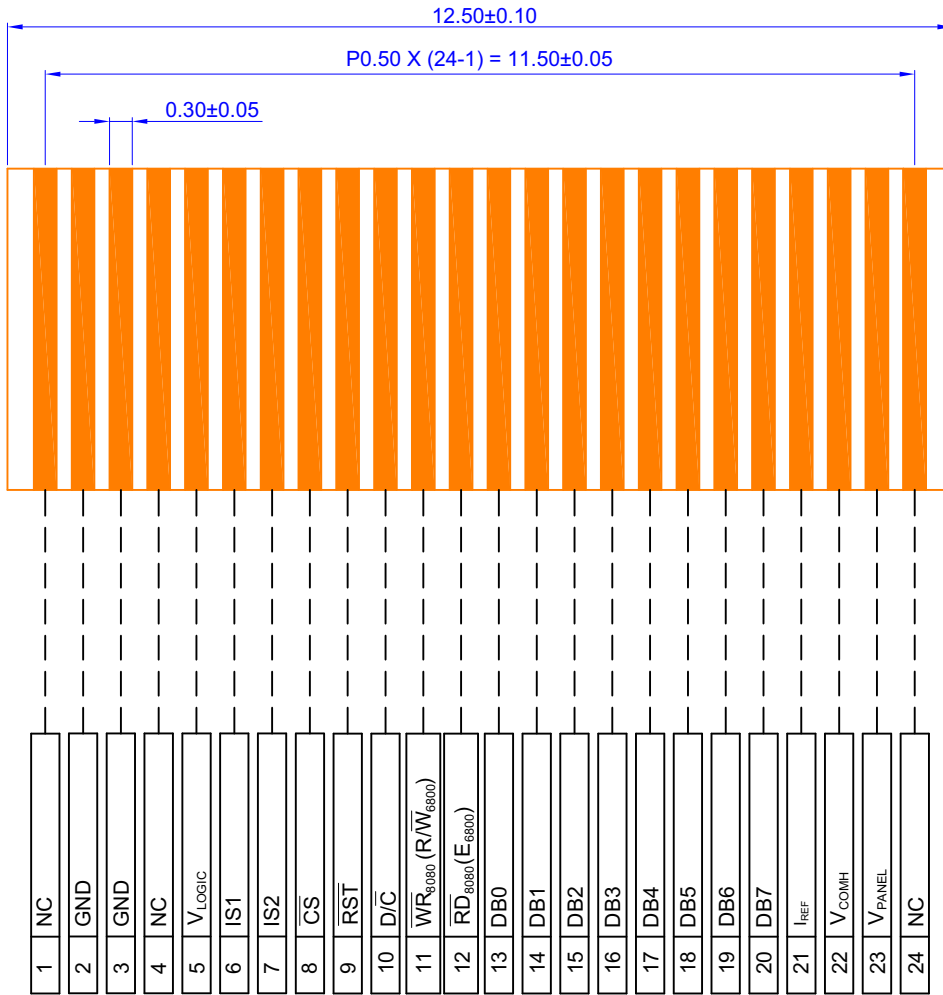

(A) Contact Side Detail

- Note: 1. Tolerance is ±0.30mm unless specified.
 2. FFC = (Flat Flexible Cable) mates with ZIF connector.
 3. Active Area Diagonal = 2.36".



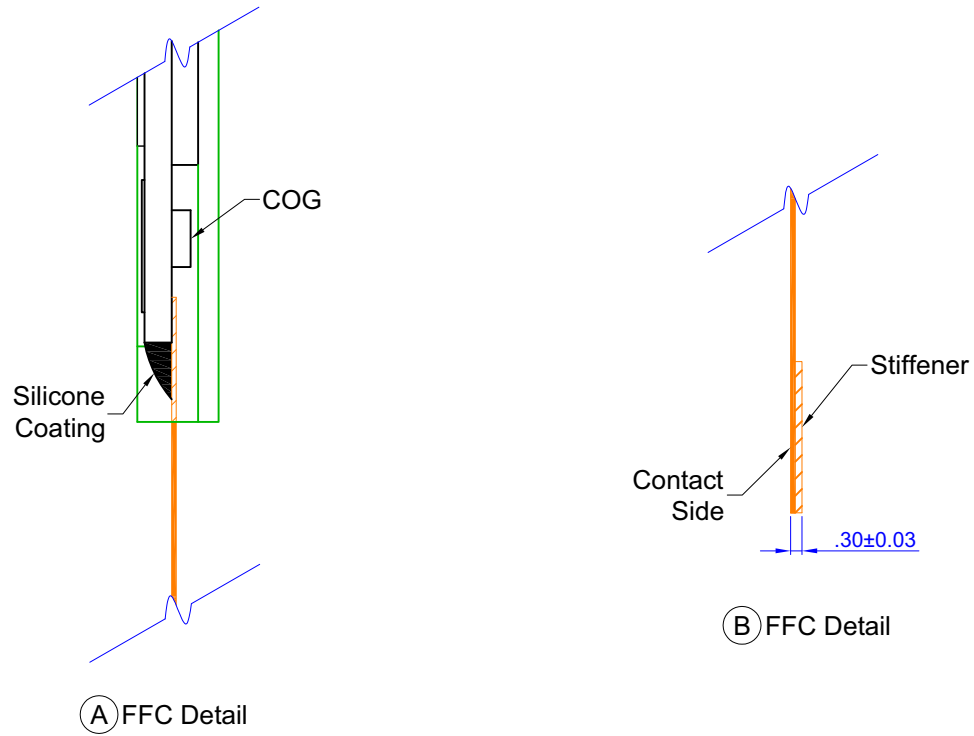

- Note: 1. Tolerance is $\pm 0.30\text{mm}$ unless specified.
 2. FFC = (Flat Flexible Cable) mates with ZIF connector.
 3. Active Area Diagonal = 2.36".





ELECTRICAL SPECIFICATIONS

SYSTEM BLOCK DIAGRAM

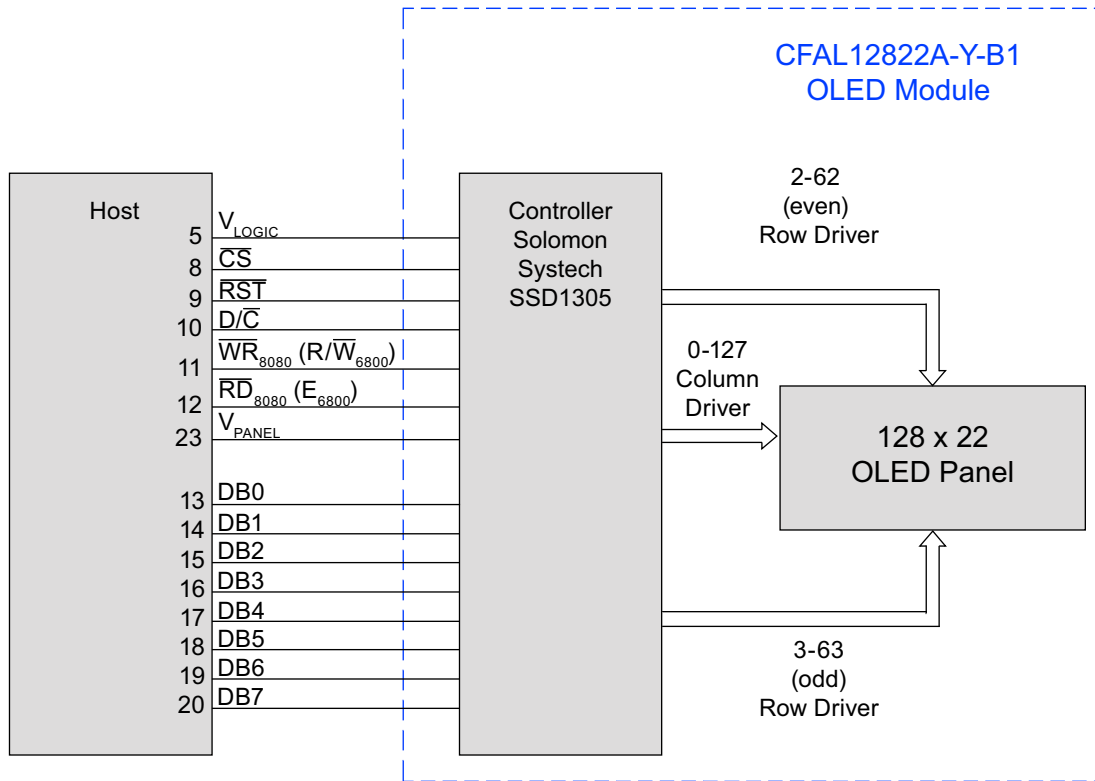

Note: Some pins omitted.

Figure 2. System Block Diagram



CIRCUIT EXAMPLE – EXTERNALLY SUPPLIED FOR DISPLAY

The [Micrel MIC2290](#) is one of many possible V_{PANEL} supply solutions.

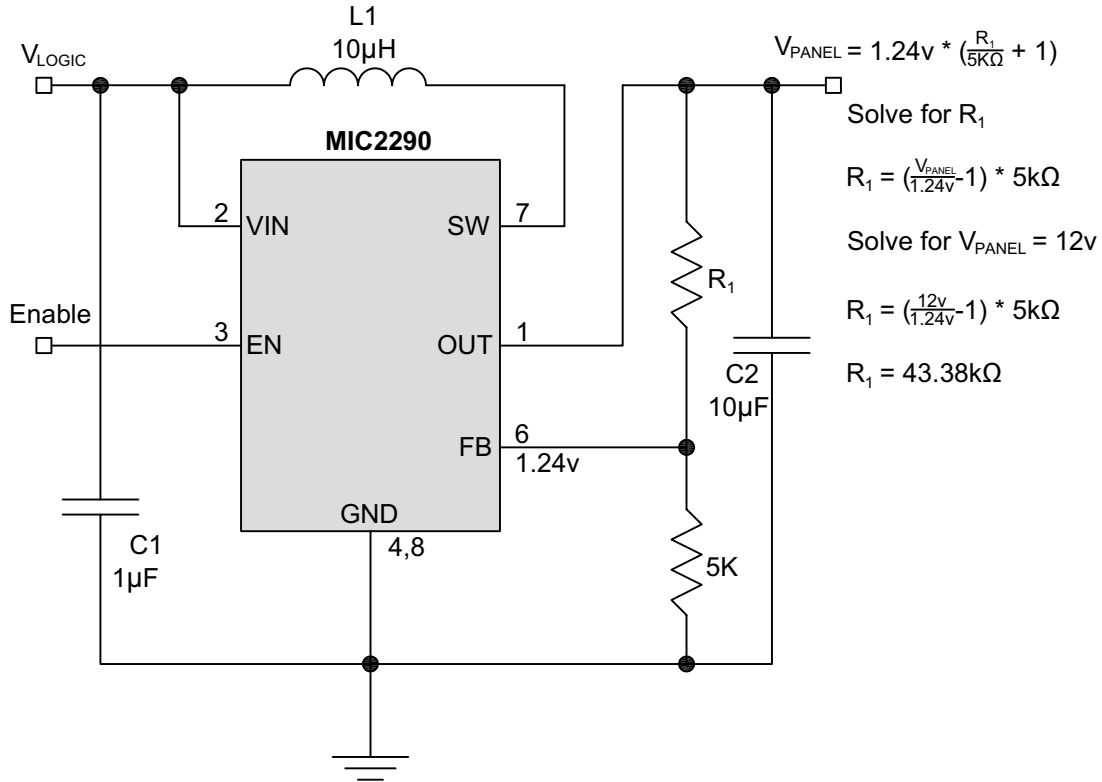

Figure 3. Circuit Example – External Supply for Display

Please refer to the Micrel MIC2290 datasheet for design details. See <http://micrel.com/page.do?page=/product-info/products/mic2290.shtml>.



POWER UP AND POWER DOWN SEQUENCING

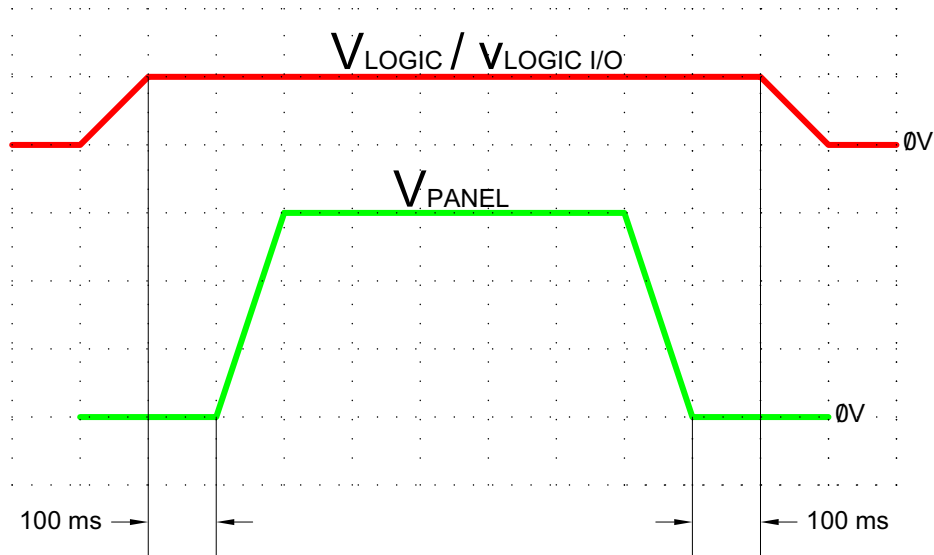

Figure 4. Power Up and Power Down Sequencing

ABSOLUTE MAXIMUM RATINGS

ABSOLUTE MAXIMUM RATINGS	SYMBOL	MINIMUM	MAXIMUM
Operating Temperature*	T_{OP}	-20°C	+70°C
Storage Temperature*	T_{ST}	-30°C	+80°C
Humidity (Noncondensing)	RH	0%	90%
Logic Supply Voltage	V_{LOGIC}	+2.4v	+3.5v
Driver Supply Voltage	V_{PANEL}	+11.5v	+12.5v
*Prolonged exposure at temperatures outside of this range may cause permanent damage to the module or decrease product lifetime.			



DC CHARACTERISTICS

DC CHARACTERISTICS	TEST CONDITION	SYMBOL	MINIMUM	TYPICAL	MAXIMUM
Logic Supply Voltage	$T_{OP} = -20^{\circ}\text{C}$ to $+70^{\circ}\text{C}$	V_{LOGIC}	+2.4v	+3.0v	+3.5v ¹
OLED Driver Supply Voltage ²	$T_{OP} = -20^{\circ}\text{C}$ to $+70^{\circ}\text{C}$	V_{PANEL}	+11.5v	+12v	+12.5v
Input High Voltage		V_{IH}	$+0.8v \times V_{Logic}$ For $V_{Logic} = +3.3v$ $V_{IH} = +0.8v \times +3.3v = +2.64v$		V_{Logic}
Input Low Voltage		V_{IL}	0v (GND)		$+0.2v \times V_{Logic}$ For $V_{Logic} = +3.3v$ $V_{IL} = +0.2v \times +3.3v = +0.66v$
Output High Voltage	$I_{OUT} = 100\mu\text{A}$ 3.3MHz	V_{OH}	$+0.9v \times V_{Logic}$ For $V_{Logic} = +3.3v$ $V_{OH} = +0.9v \times +3.3v = +2.97v$		V_{Logic}
Output Low Voltage	$I_{OUT} = 100\mu\text{A}$ 3.3MHz	V_{OL}	0v (GND)		$+0.1v \times V_{Logic}$ For $V_{Logic} = +3.3v$ $V_{OL} = +0.1v \times +3.3v = +0.33v$
Total Power	All pixels on $V_{LOGIC} = +3.0v$ $V_{PANEL} = +14.0v$ 80 cd/m ² $T_{OP} = 25^{\circ}\text{C}$	P_T		154 mW	300 mW

¹Do not exceed +3.5v maximum.

²The V_{PANEL} input must be a stable value with no ripple or noise.

This is a summary of the module's major operating parameters. For detailed information see [APPENDIX D: SOLOMON SYS-TECH SSD1305 CONTROLLER SPECIFICATION SHEET \(Pg. 37\)](#).



DETAILS OF INTERFACE PIN FUNCTION

PIN	SIGNAL	LEVEL	DIRECTION	DESCRIPTION															
1	NC			No Connection															
2	GND	0v		Ground. Must be connected to an external ground.															
3	GND	0v		Ground. Must be connected to an external ground.															
4	NC			No Connection															
5	V _{LOGIC}	+2.4v to +3.5v		Power supply input. Must be connected to an external source.															
6	IS1	H/L	I	<table border="1"> <thead> <tr> <th>IS1</th> <th>IS2</th> <th>Interface Mode</th> </tr> </thead> <tbody> <tr> <td>0</td> <td>0</td> <td>SPI (Serial)</td> </tr> <tr> <td>0</td> <td>1</td> <td>6800 Parallel</td> </tr> <tr> <td>1</td> <td>0</td> <td>Not Allowed</td> </tr> <tr> <td>1</td> <td>1</td> <td>8080 Parallel</td> </tr> </tbody> </table>	IS1	IS2	Interface Mode	0	0	SPI (Serial)	0	1	6800 Parallel	1	0	Not Allowed	1	1	8080 Parallel
IS1	IS2	Interface Mode																	
0	0	SPI (Serial)																	
0	1	6800 Parallel																	
1	0	Not Allowed																	
1	1	8080 Parallel																	
7	IS2	H/L	I																
8	$\overline{\text{CS}}$	H/L	I	<p>Chip select input.</p> <p><i>Low:</i> Controller chip is selected. Communications with the host MPU is possible.</p> <p><i>High:</i> Controller chip is not selected. MPU interface signals are ignored by the controller.</p>															
9	$\overline{\text{RST}}$	L	I	<p>Reset signal.</p> <p><i>Low:</i> Display controller is reset. The $\overline{\text{RST}}$ pin should be pulsed low shortly after power is applied.</p> <p><i>High:</i> The $\overline{\text{RST}}$ pin should be brought high for normal operation.</p>															
10	D/ $\overline{\text{C}}$	H/L	I	<p>Data/Command control. Determines whether data bits are data or command.</p> <p>1 – <i>High:</i> Addresses the data register. 2 – <i>Low:</i> Addresses the command register.</p>															



PIN	SIGNAL	LEVEL	DIRECTION	DESCRIPTION
11	\overline{WR}_{8080} (R/\overline{W}_{6800})	H/L	I	Host interface input. <i>8080 Host:</i> Active low. Signal on the data bus is latched at the rising edge of \overline{WR} signal. <i>6800 Host:</i> read/write control signal output. $R/\overline{W} = High$: Read (Host←Module) $R/\overline{W} = Low$: Write (Host→Module) <i>SPI (serial) mode:</i> Connect to ground.
12	\overline{RD}_{8080} (E_{6800})	H/L	I	Host interface input. <i>8080 Host:</i> Active low. Signal on the data bus is latched at the rising edge of \overline{WR} signal. <i>6800 Host:</i> Enable control signal input active high. $E = High$: Read or Write Active $E = Low$: No Read or Write Active <i>SPI (serial) mode:</i> Connect to ground.
13	DB0	H/L	I/O	Bidirectional data bus connects to 8-bit standard host data bus. <i>In serial mode (IS1=0, IS2=0):</i> DB0 serves as the serial clock input signal (SCL) and DB1 serves as the serial data input pin (SI). DB2-DB7 are high impedance. In serial mode, data can be written to the display but not read. Pin 11 (\overline{WR}_{8080} (R/\overline{W}_{6800})) and pin12 (\overline{RD}_{8080} (E_{6800})) are unused and should be tied low. When using <i>SPI interface</i> , DB2 should be left open. DB3-DB7 should be tied to GND (low). <i>In 6800 Parallel mode:</i> Pin 11 is used as R/\overline{W}_{6800} . Pin 12 is used as E_{6800} . Data is input or output on DB0-DB7. <i>In 8080 Parallel mode:</i> Pin 11 is used as \overline{WR}_{8080} . Pin 12 is used as \overline{RD}_{8080} . Data is input or output on DB0-DB7.
14	DB1	H/L	I/O	
15	DB2	H/L	I/O	
16	DB3	H/L	I/O	
17	DB4	H/L	I/O	
18	DB5	H/L	I/O	
19	DB6	H/L	I/O	
20	DB7	H/L	I/O	
21	I_{REF}		O	Segment output current reference for brightness adjustment. A resistor should be connected between this pin and GND. Set the current at 10 μ A.
22	V_{COMH}		O	High level voltage output for common signals. A low ESR capacitor should be connected between this pin and GND. Do not connect external power supply directly to this pin.



PIN	SIGNAL	LEVEL	DIRECTION	DESCRIPTION
23	V _{PANEL}	+11.5v to +12.5v	I	<p>Driver supply voltage. Only high voltage input on chip. Power must be supplied externally.</p> <p><i>Note: You must observe power sequencing for this pin.</i></p> <p><i>Power Up</i> – Display must be powered up and initialized before power is applied to the pin.</p> <p><i>Power Down</i> – Power must be removed from this pin before the display is powered off.</p>
24	NC			No connection

PHOTO REFERENCE FOR ZIF CONNECTOR PIN FUNCTIONS

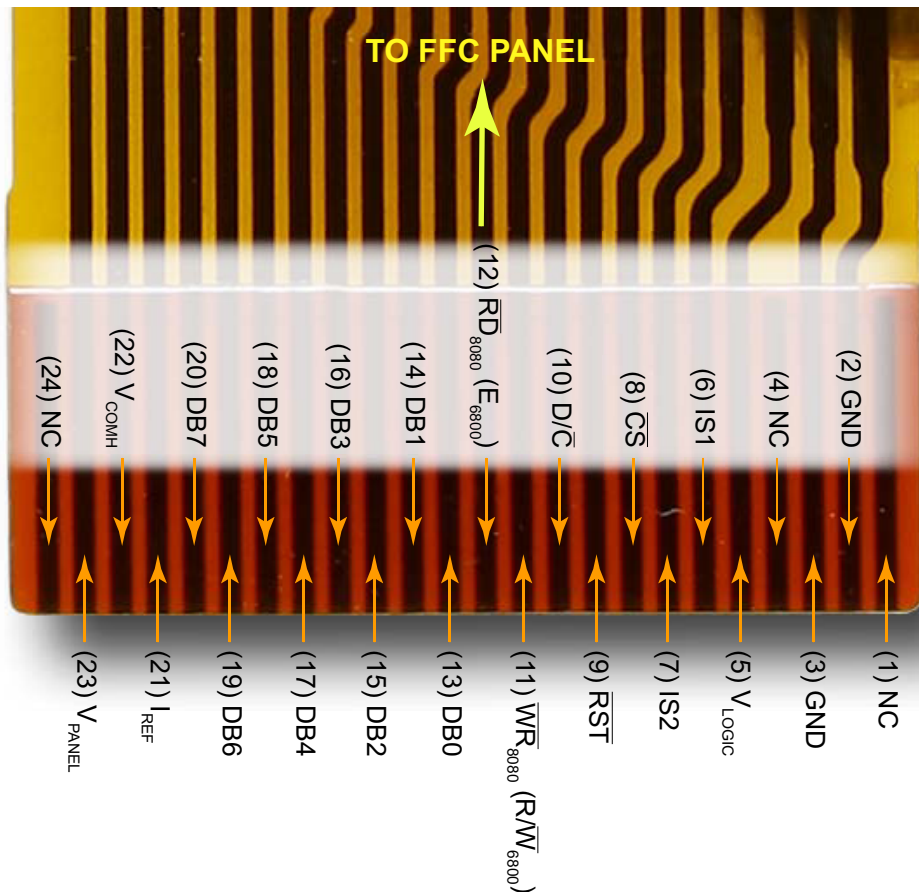

Figure 5. Back View of ZIF Connector Pins (Labeled)



ESD (ELECTRO-STATIC DISCHARGE)

The circuitry is industry standard CMOS logic and susceptible to ESD damage. Please use industry standard antistatic precautions as you would for any other static sensitive devices such as expansion cards, motherboards, or integrated circuits. Ground your body, work surfaces, and equipment.

OPTICAL SPECIFICATIONS

OPTICAL CHARACTERISTICS

ITEM	SYMBOL	TEST CONDITION	MINIMUM	TYPICAL	MAXIMUM
Viewing Angle				>160°	
Dark Room Contrast Ratio ¹	CR	80 cd/m ²		>100:1	
Response Time ²				<1 ms	
Luminous Intensity (IV)	L _{BR}	with polarizer		100 cd/m ²	
Duty					1/64

¹Contrast Ratio = (brightness with pixels light)/(brightness with pixels dark).
²Response Time: The amount of time it takes a pixel to change from active to inactive or back again.



Definition of Viewing Angle

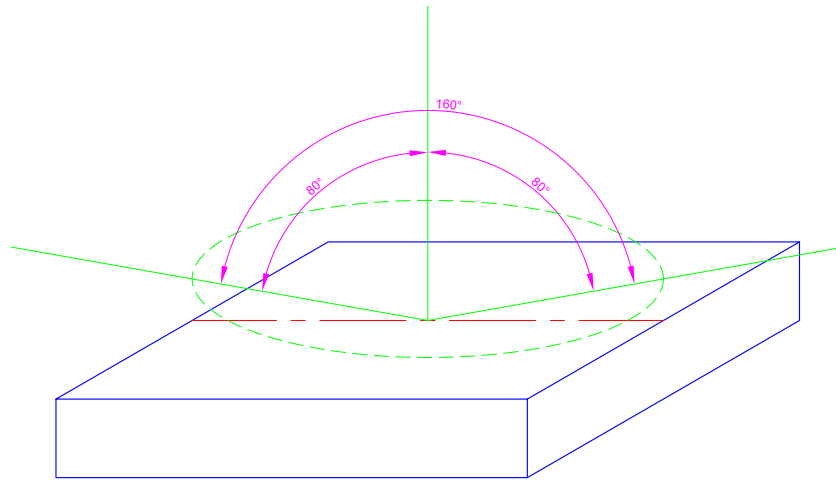

Figure 6. CFAL12822A-Y-B1 has a 160° Viewing Angle

OLED CONTROLLER INTERFACE

This module uses a Solomon Systech SSD1305 or compatible controller. For your reference, we added [APPENDIX D: SOLOMON SYSTECH SSD1305 CONTROLLER SPECIFICATION SHEET \(Pg. 37\)](#) to this Data Sheet.

MODULE RELIABILITY AND LONGEVITY

MODULE RELIABILITY

ITEM	SPECIFICATION
CFAL12822A-Y-B1	Brightness will be >50% of a new module's initial brightness for at least 20,000 hours of operation.
<i>Test Conditions:</i> <input type="checkbox"/> Accelerated test: 240 hours at 80°C operating temperature, 80 cd/m ² . <input type="checkbox"/> Test pattern is 50% alternating checkerboard. <i>Under operating and storage temperature specification limitations, humidity RH 65%, and no exposure to direct sunlight.</i>	

OLED displays are an emissive technology. Each pixel is susceptible to dimming based on its individual use (burn-in). Frequently used pixels will dim more quickly than pixels that are not used as often. Please avoid using a bright, static, high-contrast image for a long time. If you want to leave the display powered on, please use scrolling text or alternating images to "wear level" the pixels. To conserve power and display lifetime, turn off or dim the display when it is not in use.



MODULE LONGEVITY (EOL / REPLACEMENT POLICY)

Crystalfontz is committed to making all of our modules available for as long as possible. For each module we introduce, we intend to offer it indefinitely. We do not preplan a module's obsolescence. The majority of modules we have introduced are still available.

We recognize that discontinuing a module may cause problems for some customers. However, rapidly changing technologies, component availability, or low customer order levels may force us to discontinue ("End of Life", EOL) a module. For example, we must occasionally discontinue a module when a supplier discontinues a component or a manufacturing process becomes obsolete. When we discontinue a module, we will do our best to find an acceptable replacement module with the same fit, form, and function.

In most situations, you will not notice a difference when comparing a "fit, form, and function" replacement module to the discontinued module. However, sometimes a change in component or process for the replacement module results in a slight variation, perhaps an improvement, over the previous design.

Although the replacement module is still within the stated Data Sheet specifications and tolerances of the discontinued module, changes may require modification to your circuit and/or firmware. Possible changes include:

- *Controller.* A new controller may require minor changes in your code.
- *Component tolerances.* Module components have manufacturing tolerances. In extreme cases, the tolerance stack can change the visual or operating characteristics.

Please understand that we avoid changing a module whenever possible; we only discontinue a module if we have no other option. We will post Part Change Notices on the product's webpage as soon as possible. If interested, you can subscribe to future part change notifications.

CARE AND HANDLING PRECAUTIONS

For optimum operation of the module and to prolong its life, please follow the precautions below. Excessive voltage will shorten the life of the module. You must drive the display within the specified voltage limit. (See [Absolute Maximum Ratings \(Pg. 16\)](#)).

ESD (ELECTRO-STATIC DISCHARGE)

The circuitry is industry standard CMOS logic and susceptible to ESD damage. Please use industry standard antistatic precautions as you would for any other static sensitive devices such as expansion cards, motherboards, or integrated circuits. Ground your body, work surfaces, and equipment.

DESIGN AND MOUNTING

- CFAL12822A-Y-B1 mates with standard 0.5 mm 24-pin ZIF sockets such as [OR721CT-ND](#), [OR709CT-ND](#), and [OR877CT-ND](#) sold by Digi-Key.
- The exposed surface of the "glass" is actually a polarizer laminated on top of the glass. To protect the soft plastic polarizer from damage, the module ships with a protective film over the polarizer. Please peel off the protective film slowly. Peeling off the protective film abruptly may generate static electricity.
- The polarizer is made out of soft plastic and is easily scratched or damaged. When handling the module, avoid touching the polarizer. Finger oils are difficult to remove.
- To protect the soft plastic polarizer from damage, place a transparent plate (for example, acrylic, polycarbonate, or glass) in front of the module, leaving a small gap between the plate and the display surface. We use GE HP-92 Lexan, which is readily available and works well.



- Do not disassemble or modify the module.
- The display can be mounted vertically onto a front panel using a variety of methods. If the enclosure is plastic, it can be molded to have the display snap into place. A metal enclosure can use a milled faceplate with mounting tabs to secure the module. Adhesives can be used, as long as they are not similar to "super-glue" because these emit vapors that can damage the display over time.
- Do not reverse polarity to the power supply connections. Reversing polarity will immediately ruin the module.
- Use care to keep the exposed terminals clean. Contamination, including fingerprints, may make the reliability of the connection poor.
- Sharp bends can damage the FFC. Do not crease FFC. Do not bend FFC tightly against the edge of the OLED panel. Do not repeatedly bend the FFC beyond its elastic region. Limit bend radius to at least R5.00 mm.

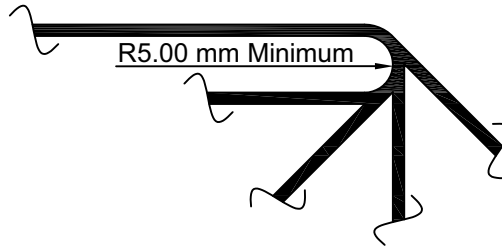

Figure 7. Limit Bend Radius of FFC

AVOID SHOCK, IMPACT, TORQUE, OR TENSION

- Do not expose the module to strong mechanical shock, impact, torque, or tension.
- Do not drop, toss, bend, or twist the module.
- Do not place weight or pressure on the module.

CLEANING

- The polarizer (laminated to the glass) is soft plastic. The soft plastic is easily scratched or damaged. Be very careful when you clean the polarizer.
- Do not clean the polarizer with liquids. Do not wipe the polarizer with any type of cloth or swab (for example, Q-tips).
- Use the removable protective film to remove smudges (for example, fingerprints) and any foreign matter. If you no longer have the protective film, use standard transparent office tape (for example, Scotch® brand "Crystal Clear Tape"). If the polarizer is dusty, you may carefully blow it off with clean, dry, oil-free compressed air.

OPERATION

- We do not recommend connecting this module to a PC's parallel port as an "end product." This module is not "user friendly" and connecting it to a PC's parallel port is often difficult, frustrating, and can result in a "dead" display due to mishandling. For more information, see our forum thread at <http://www.crystalfontz.com/forum/showthread.php?s=&threadid=3257>.
- Your circuit should be designed to protect the module from ESD and power supply transients.
- Observe the operating temperature limitations: from -20°C minimum to +70°C maximum with minimal fluctuations. Operation outside of these limits may shorten the life and/or harm the display.
- Operate away from dust, moisture, and direct sunlight.



STORAGE AND RECYCLING

- Store in an ESD-approved container away from dust, moisture, and direct sunlight, fluorescent lamps, or any ultraviolet ray.
- Observe the storage temperature limitations: from -30°C minimum to +80°C maximum with minimal fluctuations. Rapid temperature changes can cause moisture to form, resulting in permanent damage.
- Do not allow weight to be placed on the modules while they are in storage.
- Please recycle your outdated Crystalfontz modules at an approved facility.



APPENDIX A: QUALITY ASSURANCE STANDARDS

INSPECTION CONDITIONS

- Environment
 - Temperature: $25\pm 5^{\circ}\text{C}$
 - Humidity: 30~85% RH (noncondensing)
- For visual inspection of active display area
 - Source lighting: two 20-Watt or one 40-Watt fluorescent light
 - Display adjusted for best contrast
 - Viewing distance: 30 ± 5 cm (about 12 inches)
 - Viewing angle: inspect at 45° angle of vertical line right and left, top and bottom

COLOR DEFINITIONS

We try to describe the appearance of our modules as accurately as possible. For the photos, we adjust for optimal appearance. Actual display appearance may vary due to (1) different operating conditions, (2) small variations of component tolerances, (3) inaccuracies of our camera, (4) color interpretation of the photos on your monitor, and/or (5) personal differences in the perception of color.

DEFINITION OF ACTIVE AREA AND VIEWING AREA

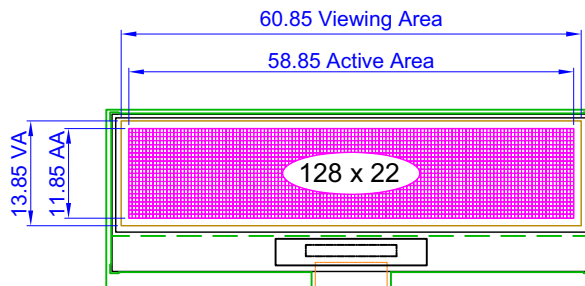



ACCEPTANCE SAMPLING

DEFECT TYPE	AQL*
Major	$\leq .65\%$
Minor	$<1.0\%$
* Acceptable Quality Level: maximum allowable error rate or variation from standard	

DEFECTS CLASSIFICATION

Defects are defined as:

- Major Defect: results in failure or substantially reduces usability of unit for its intended purpose
- Minor Defect: deviates from standards but is not likely to reduce usability for its intended purpose

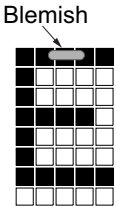
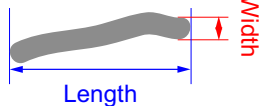
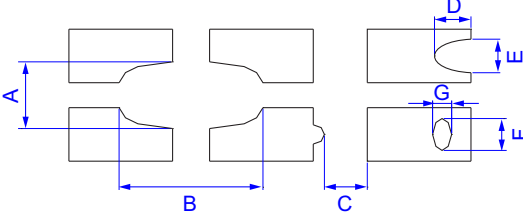

ACCEPTANCE STANDARDS

#	DEFECT TYPE	CRITERIA			MAJOR / MINOR	
1	Electrical defects	1. No display, display malfunctions, or shorted segments. 2. Current consumption exceeds specifications.			Major	
2	Viewing area defect	Viewing area does not meet specifications.			Major	
3	Blemishes or foreign matter on display segments		<i>Defect Size</i>	<i>Acceptable Qty</i>	Minor	
			≤ 0.30 mm	3		
			≤ 2 defects within 10 mm of each other			
4	Dark lines or scratches in display area		<i>Defect Width</i>	<i>Defect Length</i>	<i>Acceptable Qty</i>	Minor
			≤ 0.03 mm	≤ 3.0 mm	3	
			0.03 to 0.05	≤ 2.0 mm	2	
			0.05 to 0.08	≤ 2.0 mm	1	
			0.08 to 0.10	≤ 3.0 mm	0	
			≥ 0.10	> 3.0 mm	0	
5	Bubbles between polarizer film and glass		<i>Defect Size</i>	<i>Acceptable Qty</i>	Minor	
			≤ 0.20 mm	Ignore		
			0.20 to 0.40 mm	3		
			0.40 to 0.60 mm	2		
			≥ 0.60 mm	0		
6	Display pattern defect		<i>Pixel Size</i>	<i>Acceptable Qty</i>	Minor	
			$((A+B)/2) \leq 0.20$ mm	≤ 3 total defects ≤ 2 pinholes per digit		
			$C > 0$ mm			
			$((D+E)/2) \leq 0.25$ mm			
			$((F+G)/2) \leq 0.25$ mm			



#	DEFECT TYPE	CRITERIA	MAJOR / MINOR
7	PCB defects	<ol style="list-style-type: none">1. Oxidation or contamination on connectors.*2. Wrong parts, missing parts, or parts not in specification.*3. Jumpers set incorrectly.4. Solder (if any) on bezel, LED pad, zebra pad, or screw hole pad is not smooth. *Minor if display functions correctly. Major if the display fails.	Minor
8	Soldering defects	<ol style="list-style-type: none">1. Unmelted solder paste.2. Cold solder joints, missing solder connections, or oxidation.*3. Solder bridges causing short circuits.*4. Residue or solder balls.5. Solder flux is black or brown. *Minor if display functions correctly. Major if the display fails.	Minor



APPENDIX B: SAMPLE CODE

SOURCES FOR DRIVER LIBRARIES

Graphic driver libraries may save a lot of time and help you develop a more professional product. Possible library sources are [easyGUI](#), [en.radzio.dxp.pl](#), [Gwentech](#), [Micrium](#), [RAMTEX](#), and [Segger emWin](#).

SAMPLE CODE

This code will initialize the display and then show an image, toggling between inverted and not inverted. You can download the complete source from this link: <http://www.crystalfontz.com/products/document/1827/CFAL12822A.zip>.

Note: Please observe V_{PANEL} sequencing as described in [Details of Interface Pin Function \(Pg. 18\)](#). See also [Power Up and Power Down Sequencing \(Pg. 16\)](#).

```
#include <avr/io.h>
#include <util/delay.h>

//This is the display memory.
volatile unsigned char display[8][132]; //1024 bytes

// all on PORTC
#define OLED_DC (1 << 7)
#define OLED_RW (1 << 6)
#define OLED_E (1 << 5)
#define OLED_CS (1 << 4)
#define OLED_RES(1 << 2)

uint8_t logo[8][132] =
{
SEE FULL LISTING
};/*****/
void delay(uint32_t twait)
{
    while (twait--)
        asm volatile ("nop");
}
/*****/
void oled_cmd(uint8_t cmd)
{
    PORTA = cmd;// set up data on bus

    PORTC &= ~(OLED_DC | OLED_RW | OLED_CS);// command mode, write mode, chip select

    // toggle E
    PORTC |= OLED_E;
    PORTC &= ~OLED_E;

    PORTC |= OLED_CS;// remove chip select
}
/*****/
void oled_dat(uint8_t dat)
{
    PORTA = dat;// set up data on bus

    PORTC |= OLED_DC;// data mode
    PORTC &= ~(OLED_RW | OLED_CS);// write mode, chip select

    // toggle E
```



```

PORTC |= OLED_E;
PORTC &= ~OLED_E;

PORTC |= OLED_CS; // remove chip select
}
/*****/
void oled_clr(uint8_t color)
{
    int i,p;

    oled_cmd(0x40);

    for (p=0;p<8;p++) // pages
    {
        oled_cmd(0xb0 + p);
        oled_cmd(0x10);
        oled_cmd(0x00);
        for (i=0;i<132;i++)
        {
            oled_dat(color);
        }
    }
}
/*****/
typedef uint8_t bitmap_t[8][132];

void bmp(bitmap_t b)
{
    int i,j, index;

    for (j=0;j<8;j++)
    {
        oled_cmd(0xB0+j);
        oled_cmd(0x10);
        oled_cmd(0x00);

        for(i=0;i<128;i++)
            oled_dat( b[j][i] );
    }
}
/*****/
int main( void )
{
    PORTD = 0; // all off

    DDRD |= (1<<3); // VPP output

    DDRA = 0xFF;

    //6800 mode
    PORTC = 0b11011110;

    DDRC = 0xFE;

    delay(20000L);

    PORTC &= ~OLED_RES;
    delay(10000);
    PORTC |= OLED_RES;

    delay(20000);

    // enable VPP
    PORTD |= (1<<3);

```



```
delay(200000L);

oled_cmd(0xae); //Set Display ON/OFF
oled_cmd(0xad); //master configuration
oled_cmd(0x8e); //second byte

oled_cmd(0xa8); //Set Mux
oled_cmd(0x16); //22 mux

oled_cmd(0x40); //display start line 0

oled_cmd(0x81); //set contrast control
oled_cmd(0x40); //second byte

oled_cmd(0xd5); //Set Display Clock Divide Ratio/Oscillator Frequency
oled_cmd(0x20); //105hz

oled_cmd(0xd8); //Set Area Color Mode ON/OFF & LowPower Display Mode
oled_cmd(0x00); //second byte

oled_cmd(0xaf); //Set Display ON

delay(5000L);

oled_clr(0);

delay(20000L);

while (1)
{
    bmp(logo);
    delay(5000000L);
    oled_cmd(0xa7); //Inverse display
    bmp(logo);
    delay(5000000L);
    oled_cmd(0xa6); //Normal display
}

return 0;
}
```



APPENDIX C: OLED MODULE TERMS AND SYMBOLS

Symbol	Description
C	Capacitor
cd/m ² nit	Candela meter squared is the standard unit of measurement for luminous intensity (photometric brightness).
CIE	A color model based on human perception developed by the CIE (Commission Internationale de l'Eclairage) committee.
CLS	Clock select pin.
COF COT TAB	Chip On Flex. Controller is on the FPC. Similar in appearance to "TAB." The flex circuit on COF is typically much thinner than the flex of a "flex tail."
COG	Chip On Glass. Controller is on the glass panel.
COM	Common driver. Common signal output for OLED display.
CR	Contrast Ratio = (brightness with pixels light)/(brightness with pixels dark).
$\overline{\text{CS}}$ CS# CSB	Chip select input. <i>Low:</i> Controller chip is selected. Communications with host is possible. <i>High:</i> Controller chip is not selected. Host interface signals are ignored by the controller.
D	Diode
DB0 ~ DBn D0 ~ Dn	Bidirectional databus connects to 8-bit or 16-bit standard host databus. When SPI (serial interface) is selected, DB0 serves as the serial clock input signal (SCL or SCLK) and DB1 serves as the serial data input signal (SI or SDIN). DB2 to DBn are set to high impedance.
$\overline{\text{D/C}}$ RS A0 CD D/C# SD/C	Data/Command control. Determines whether data bits are data or command. <i>1 – High:</i> Addresses the data register. <i>0 – Low:</i> Addresses the command register.
ESD	Electro-Static Discharge. Sudden and brief electrical current that flows between two objects. ESD between a human and a OLED module can cause permanent damage.
FB	Feedback input for the booster circuit. Use to adjust booster output voltage level, V _{PANEL} .
FFC	Flat Flex Cable. Used for Touch Screen connection. Also called "pigtail."
FG	Frame Ground.
FPC	Flexible Printed Circuit. Also called "flex tail." Typically much thicker than the "flex" film of COF (Chip On Flex).
GDR	Gate Drive. Output signal drives the gate of the external NMOS of the booster circuit.



Symbol	Description (Continued)															
GND V _{SS}	Power supply and signal ground. Must be connected to an external ground.															
I _{LOGIC} I _{DD}	Operating current for V _{LOGIC} .															
I _{LOGIC, SLEEP} I _{DD, SLEEP}	Sleep mode current for V _{LOGIC} .															
I _{PANEL} I _{CC}	Supply current for V _{PANEL} .															
I _{PANEL, SLEEP} I _{CC, SLEEP}	Sleep mode current for V _{PANEL} .															
I _{REF}	Segment output current reference for brightness adjustment. A resistor should be connected between this pin and GND. Used to set the current.															
I/O	Input/Output.															
IM _n	Interface mode select pin. (Where <i>n</i> is the corresponding number.)															
IS1 BS1 C86 M80	<table border="1"> <thead> <tr> <th>IS1</th> <th>IS2</th> <th>Interface Mode</th> </tr> </thead> <tbody> <tr> <td>0</td> <td>0</td> <td>SPI (Serial), if available</td> </tr> <tr> <td>0</td> <td>1</td> <td>6800 Parallel, if available</td> </tr> <tr> <td>1</td> <td>0</td> <td>Not Allowed</td> </tr> <tr> <td>1</td> <td>1</td> <td>8080 Parallel</td> </tr> </tbody> </table>	IS1	IS2	Interface Mode	0	0	SPI (Serial), if available	0	1	6800 Parallel, if available	1	0	Not Allowed	1	1	8080 Parallel
IS1		IS2	Interface Mode													
0		0	SPI (Serial), if available													
0		1	6800 Parallel, if available													
1	0	Not Allowed														
1	1	8080 Parallel														
IS2 BS2 P/S MS MS̄ M/S#																
L _{BRNORMAL} IV	Luminous Intensity Brightness, NORMAL operation.															
L _{BRSTANDBY} IV	Luminous Intensity Brightness, STANDBY.															
mm	Millimeter or millimetre. Unit of length equal to one thousandth of a meter. 1 millimeter = 0.0394 inches.															
mW	Milliwatt is equal to one thousandth of a Watt. Watts = Volts x Amps.															
NC nc	Make no connection.															
OLED	Organic light-emitting diode.															
P _{OPERATION} P _T	Normal mode Power consumption.															
P _{STANDBY}	Standby mode Power consumption.															



Symbol	Description (Continued)
Q	Transistor, including FET and MOSFET.
R	Resistor
\overline{RD}_{8080} (E_{6800}) \overline{RD} (E) E (\overline{RD}) E RDB	Host interface input. <i>8080 Host:</i> Active low. Signal on the databus is latched at the rising edge of \overline{RD} . <i>6800 Host (if available):</i> Enable control signal input active high. E = High: Read or Write operation is active. E = Low: No operation.
RH Rh	Relative Humidity.
RoHS	Restriction of Hazardous Substances Directive, an environmental standard.
\overline{RST} \overline{RES} RST# RES# RSTB RESET	Reset signal. <i>Low:</i> Display controller is reset. The \overline{RST} pin should be pulsed low shortly after power is applied. <i>High:</i> The \overline{RST} pin should be brought high for normal operation.
SCL SCK	Serial Clock signal.
SDO MISO	Data output pin in serial interface. SDO = Serial Data Out MISO = Master In, Slave Out
SEG	Segment driver. Segment signal output for OLED display.
SENSE	Source current for external NMOS of booster circuit.
SI SDI MOSI	Data input pin in serial interface. SDI = Serial Data In MOSI - Master Out, Slave In
SW	Switch output drives the gate of the external NMOS of the booster circuit.
T _a TA	“Ambient temperature” is the temperature of the air that surrounds a component.
T _{OP}	Operating temperature.
T _{ST} T _{STG}	Storage Temperature.
V _{BREF}	Internal voltage reference for booster circuit. A decoupling capacitor, typically 1μF, should be connected to GND.

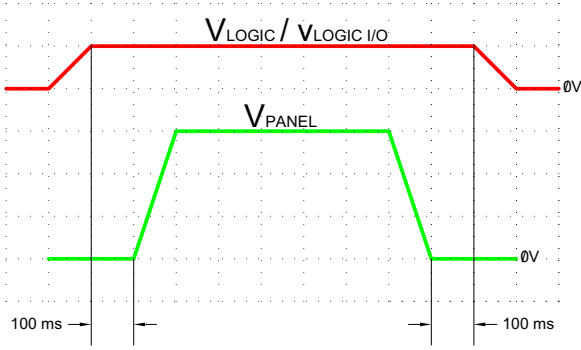

Symbol	Description (Continued)
V_{COL}	Column Supply Voltage. This is odd and even column supply voltage. It can be supplied externally or by connecting to V_{PANEL} .
V_{COMH}	High level voltage output for common signals. A low ESR capacitor should be connected between this pin and GND. Do not connect external power supply directly to this pin.
V_{IH} V_{ICH}	High level input voltage.
V_{IL} V_{LCH}	Low level input voltage.
V_{LOGIC}	Power supply input. Must be connected to an external source.
$V_{LOGIC\ I/O}$ V_{DD} V_{DD1} V_{CC} (if it has PCB) $V_{DD\ I/O}$ $V_{I/O}$ V_{CCIO}	Supply voltage for I/O signals.
V_{OH} V_{OHC}	High level output voltage.
V_{OL} V_{OLC}	Low level output voltage.
V_{PANEL} V_{PP} V_{CC} (if no PCB)	<p>Driver supply voltage. Only high voltage input on chip. Power must be supplied externally. <i>Note: You must observe power sequencing for this signal.</i></p> <p><i>Power Up</i> – Display must be powered up and initialized before power is applied to the signal.</p> <p><i>Power Down</i> – Power must be removed from this signal before the display is powered off.</p> 
V_{REF}	Voltage reference pin for pre-charge voltage in driving OLED device. Voltage should be set to match with the OLED driving voltage in current drive phase. It can either be supplied externally or by connecting to V_{PANEL} .



Symbol	Description (Continued)
V_{ROW}	Row Driver Supply. This is odd and even row power supply. It can be supplied externally or by connecting to V_{PANEL} .
V_{SL}	Segment voltage reference pin. This pin should be left open.
\overline{WR}_{8080} (R/\overline{W}_{6800}) $\overline{R/\overline{W}}$ (\overline{WR}) \overline{WR} (R/\overline{W}) $R/W\#$ WRB	<p>Host interface input.</p> <p><i>8080 Host:</i> Active low. Signal on the databus is latched at the rising edge of \overline{WR} signal.</p> <p><i>6800 Host (if available):</i> Read/Write control signal output.</p> <p>R/\overline{W} = High: Read (Host←Module)</p> <p>R/\overline{W} = Low: Write (Host→Module)</p>



APPENDIX D: SOLOMON SYSTECH SSD1305 CONTROLLER SPECIFICATION SHEET

The complete *Solomon Systech 132 x 64 Dot Matrix OLED/PLED Segment/Common Driver with Controller Data Sheet* (Rev 2.0, Oct 2008, 71 pages) follows.

SSD1305

Advance Information

132 x 64 Dot Matrix OLED/PLED Segment/Common Driver with Controller

This document contains information on a new product. Specifications and information herein are subject to change without notice.

<http://www.solomon-systech.com>

SSD1305

Rev 2.0

P 1/71

Oct 2008

Copyright © 2008 **Solomon Systech Limited**



Appendix: IC Revision history of SSD1305 Specification

Version	Change Items	Effective Date
1.0	Change to Advance Info.	27-Mar-06
1.1	Revise command 91h Add a note on the capacitor value in Section 13 Application Example Add I2C Interface	28-Apr-06
1.2	Revise CL pin description in Table 7-1 Revise Figure 10-6	26-Jun-06
1.3	Revise section 8.1.2 & Section 13 Add Figure 10-7	17-Aug-06
1.4	Remove software reset command (E2h) Revise command 26h/27h/29h/2Ah (Set time interval between each scroll step)	06-Sep-06
1.5	Revise Figure 14-1 Application Example Revise Die thickness to 457um from 475um	22-Sep-06
1.6	Revise “Bump Size” of pin “127-147, 294-314” Revise Figure 10-6 ,Figure 8-5 , Figure 13-4	21-Dec-06
1.7	Add light sensitive note In Section 11 – Maximum ratings Revise Note 2 in Section 8.10 Power ON/OFF sequence by adding the word “disable” Add China RoHS disclaimer at the last page.	16-May-07
1.8	For SPI/6800/8080 MCU interface, change the Rise / Fall time (tR/tF) to max. 40ns Revise typo in SSD1305T6R1 dwg on P.68 pitch: From 0.85 change to 0.845	02-Aug-07
1.9	Add SSD1305Z3 in ordering information & add die tray Revise CL pin to “connected to VSS” in Section 8.3 Revise typo in page 42 : from “upper column address is 00h” to “upper column address is 10h”	23-May-08
2.0	Add IC revision history on spec	27-Oct-08

CONTENTS

1	GENERAL DESCRIPTION	8
2	FEATURES	8
3	ORDERING INFORMATION	8
4	BLOCK DIAGRAM	9
5	DIE PAD FLOOR PLAN	10
6	PIN ARRANGEMENT	13
6.1	SSD1305T6R1 PIN ASSIGNMENT.....	13
6.2	SSD1305T7R1 PIN ASSIGNMENT.....	15
7	PIN DESCRIPTION	17
8	FUNCTIONAL BLOCK DESCRIPTIONS	19
8.1	MCU INTERFACE SELECTION.....	19
8.1.1	MCU Parallel 6800-series Interface.....	19
8.1.2	MCU Parallel 8080-series Interface.....	20
8.1.3	MCU Serial Interface.....	22
8.1.4	MCU I ² C Interface.....	22
8.2	COMMAND DECODER	25
8.3	OSCILLATOR CIRCUIT AND DISPLAY TIME GENERATOR.....	26
8.4	FR SYNCHRONIZATION	27
8.5	RESET CIRCUIT	27
8.6	SEGMENT DRIVERS / COMMON DRIVERS	28
8.7	GRAPHIC DISPLAY DATA RAM (GDDRAM).....	30
8.8	AREA COLOR DECODER.....	31
8.9	SEG/COM DRIVING BLOCK	32
8.10	POWER ON AND OFF SEQUENCE	33
9	COMMAND TABLE	34
9.1	DATA READ / WRITE	40
10	COMMAND DESCRIPTIONS	41
10.1	FUNDAMENTAL COMMAND	41
10.1.1	Set Lower Column Start Address for Page Addressing Mode (00h~0Fh)	41
10.1.2	Set Higher Column Start Address for Page Addressing Mode (10h~1Fh)	41
10.1.3	Set Memory Addressing Mode (20h).....	41
10.1.4	Set Column Address (21h)	42
10.1.5	Set Page Address (22h).....	43
10.1.6	Set Display Start Line (40h~7Fh)	44
10.1.7	Set Contrast Control for BANK0 (81h).....	44
10.1.8	Set Brightness for Area Color Banks (82h).....	44
10.1.9	Set Look Up Table (LUT) (91h).....	44
10.1.10	Set Bank Color of BANK1 to BANK16 (PAGE0) (92h)	45
10.1.11	Set Bank Color of BANK17 to BANK32 (PAGE0) (93h)	45
10.1.12	Set Segment Re-map (A0h/A1h).....	45
10.1.13	Entire Display ON (A4h/A5h).....	45
10.1.14	Set Normal/Inverse Display (A6h/A7h).....	45
10.1.15	Set Multiplex Ratio (A8h).....	45
10.1.16	Reserved (AAh)	45
10.1.17	Dim Mode setting (ABh)	45
10.1.18	Master Configuration (ADh).....	45

10.1.19	Set Display ON/OFF (ACh/AEh/AFh).....	46
10.1.20	Set Page Start Address for Page Addressing Mode (B0h~B7h).....	46
10.1.21	Set COM Output Scan Direction (C0h/C8h).....	46
10.1.22	Set Display Offset (D3h).....	46
10.1.23	Set Display Clock Divide Ratio/ Oscillator Frequency (D5h).....	49
10.1.24	Set Area Color Mode ON/OFF & Low Power Display Mode (D8h).....	49
10.1.25	Set Pre-charge Period (D9h).....	49
10.1.26	Set COM Pins Hardware Configuration (DAh).....	50
10.1.27	Set V _{COMH} Deselect Level (DBh).....	52
10.1.28	Enter Read Modify Write (E0h).....	52
10.1.29	NOP (E3h).....	53
10.1.30	Exit Read Modify Write (EEh).....	53
10.1.31	Status register Read.....	53
10.2	GRAPHIC ACCELERATION COMMAND.....	54
10.2.1	Horizontal Scroll Setup (26h/27h).....	54
10.2.2	Continuous Vertical and Horizontal Scroll Setup (29h/2Ah).....	55
10.2.3	Deactivate Scroll (2Eh).....	56
10.2.4	Activate Scroll (2Fh).....	56
10.2.5	Set Vertical Scroll Area(A3h).....	57
11	MAXIMUM RATINGS.....	58
12	DC CHARACTERISTICS.....	59
13	AC CHARACTERISTICS.....	60
14	APPLICATION EXAMPLE.....	65
15	PACKAGE INFORMATION.....	66
15.1	SSD1305Z DIE TRAY INFORMATION.....	66
15.2	SSD1305T6R1 DETAIL DIMENSION.....	67
15.3	SSD1305T7R1 DETAIL DIMENSION.....	69
15.4	SSD1305Z3 DIE TRAY INFORMATION.....	70

TABLES

TABLE 3-1 : ORDERING INFORMATION	8
TABLE 5-1 : SSD1305Z BUMP DIE PAD COORDINATES	12
TABLE 6-1 : SSD1305T6R1 PIN ASSIGNMENT TABLE	14
TABLE 6-2 : SSD1305T7R1 PIN ASSIGNMENT	16
TABLE 7-1 : PIN DESCRIPTION	17
TABLE 7-2 : MCU BUS INTERFACE PIN SELECTION	18
TABLE 8-1 : MCU INTERFACE ASSIGNMENT UNDER DIFFERENT BUS INTERFACE MODE.....	19
TABLE 8-2 : CONTROL PINS OF 6800 INTERFACE	19
TABLE 8-3 : CONTROL PINS OF 8080 INTERFACE (FORM 1)	21
TABLE 8-4 : CONTROL PINS OF 8080 INTERFACE (FORM 2)	21
TABLE 8-5 : CONTROL PINS OF SERIAL INTERFACE	22
TABLE 9-1: COMMAND TABLE	34
TABLE 9-2 : READ COMMAND TABLE	40
TABLE 9-3 : ADDRESS INCREMENT TABLE (AUTOMATIC).....	40
TABLE 10-1 : EXAMPLE OF SET DISPLAY OFFSET AND DISPLAY START LINE WITH NO REMAP	47
TABLE 10-2 :EXAMPLE OF SET DISPLAY OFFSET AND DISPLAY START LINE WITH REMAP	48
TABLE 10-3 : COM PINS HARDWARE CONFIGURATION.....	50
TABLE 10-4 : EXAMPLE OF READ MODIFY WRITE MODE	53
TABLE 11-1 : MAXIMUM RATINGS (VOLTAGE REFERENCED TO V_{SS})	58
TABLE 12-1 : DC CHARACTERISTICS	59
TABLE 13-1 : AC CHARACTERISTICS	60
TABLE 13-2 : 6800-SERIES MCU PARALLEL INTERFACE TIMING CHARACTERISTICS	61
TABLE 13-3 : 8080-SERIES MCU PARALLEL INTERFACE TIMING CHARACTERISTICS	62
TABLE 13-4 : SERIAL INTERFACE TIMING CHARACTERISTICS	63
TABLE 13-5 :I ² C INTERFACE TIMING CHARACTERISTICS	64

FIGURES

FIGURE 4-1 : SSD1305 BLOCK DIAGRAM.....	9
FIGURE 5-1 : SSD1305Z DIE DRAWING.....	10
FIGURE 5-2 : SSD1305Z ALIGNMENT MARKS DIMENSION.....	11
FIGURE 6-1 : SSD1305T6R1 PIN ASSIGNMENT	13
FIGURE 6-2 : SSD1305T7R1 PIN ASSIGNMENT	15
FIGURE 8-1 : DATA READ BACK PROCEDURE - INSERTION OF DUMMY READ.....	20
FIGURE 8-2 : EXAMPLE OF WRITE PROCEDURE IN 8080 PARALLEL INTERFACE MODE.....	20
FIGURE 8-3 : EXAMPLE OF READ PROCEDURE IN 8080 PARALLEL INTERFACE MODE.....	20
FIGURE 8-4 : DISPLAY DATA READ BACK PROCEDURE - INSERTION OF DUMMY READ	21
FIGURE 8-5 : WRITE PROCEDURE IN SPI MODE.....	22
FIGURE 8-6 : I ² C -BUS DATA FORMAT.....	23
FIGURE 8-7 : DEFINITION OF THE START AND STOP CONDITION.....	24
FIGURE 8-8 : DEFINITION OF THE ACKNOWLEDGEMENT CONDITION.....	25
FIGURE 8-9 : DEFINITION OF THE DATA TRANSFER CONDITION	25
FIGURE 8-10 : OSCILLATOR CIRCUIT AND DISPLAY TIME GENERATOR	26
FIGURE 8-11 : SEGMENT OUTPUT WAVEFORM IN THREE PHASES.....	28
FIGURE 8-12 : SEGMENT OUTPUT WAVEFORM FOR TWO DIFFERENT COLORS LUT SETTING.....	28
FIGURE 8-13 : EXAMPLE OF SEGMENT OUTPUT WAVEFORM OF MONOCHROME DISPLAY SECTION UNDER MONOCHROME MODE.....	29
FIGURE 8-14 : EXAMPLE OF SEGMENT OUTPUT WAVEFORM OF AREA COLOR DISPLAY SECTION UNDER AREA COLOR MODE.....	29
FIGURE 8-15 : GDDRAM PAGES STRUCTURE OF SSD1305	30
FIGURE 8-16 : ENLARGEMENT OF GDDRAM (NO ROW RE-MAPPING AND COLUMN-RE-MAPPING)	30
FIGURE 8-17 : EXAMPLE OF AREA COLOR ASSIGNMENT ON A 132X64 OLED PANEL	31
FIGURE 8-18 : I _{REF} CURRENT SETTING BY RESISTOR VALUE	32
FIGURE 8-19 : THE POWER ON SEQUENCE.....	33
FIGURE 8-20 : THE POWER OFF SEQUENCE	33
FIGURE 10-1 : ADDRESS POINTER MOVEMENT OF PAGE ADDRESSING MODE.....	41
FIGURE 10-2 : EXAMPLE OF GDDRAM ACCESS POINTER SETTING IN PAGE ADDRESSING MODE (NO ROW AND COLUMN-RE-MAPPING)	41
FIGURE 10-3 : ADDRESS POINTER MOVEMENT OF HORIZONTAL ADDRESSING MODE.....	42
FIGURE 10-4 : ADDRESS POINTER MOVEMENT OF VERTICAL ADDRESSING MODE	42
FIGURE 10-5 : EXAMPLE OF COLUMN AND ROW ADDRESS POINTER MOVEMENT.....	43
FIGURE 10-6 : SEGMENT CURRENT VS CONTRAST SETTING.....	44
FIGURE 10-7 : TRANSITION BETWEEN DIFFERENT MODES	46
FIGURE 10-8 : TYPICAL OSCILLATOR FREQUENCY ADJUSTMENT BY D5 COMMAND (V _{DD} =2.8V).....	49
FIGURE 10-9 : HORIZONTAL SCROLL EXAMPLE: SCROLL RIGHT BY 4 COLUMNS	54
FIGURE 10-10 : HORIZONTAL SCROLL EXAMPLE: SCROLL LEFT BY 2 COLUMNS.....	54
FIGURE 10-11 : HORIZONTAL SCROLLING SETUP EXAMPLE	54
FIGURE 10-12 : CONTINUOUS VERTICAL AND HORIZONTAL SCROLLING SETUP EXAMPLES.....	55
FIGURE 10-13 : CONTINUOUS VERTICAL AND HORIZONTAL SCROLLING EXAMPLE: WITH SETTING IN MUX RATIO	56
FIGURE 10-14 : VERTICAL SCROLL AREA SETUP EXAMPLES	57
FIGURE 13-1 : 6800-SERIES MCU PARALLEL INTERFACE CHARACTERISTICS	61
FIGURE 13-2 : 8080-SERIES PARALLEL INTERFACE CHARACTERISTICS (FORM 1)	62
FIGURE 13-3 : 8080-SERIES PARALLEL INTERFACE CHARACTERISTICS (FORM 2)	62
FIGURE 13-4 : SERIAL INTERFACE CHARACTERISTICS	63
FIGURE 13-5 : I ² C INTERFACE TIMING CHARACTERISTICS	64
FIGURE 14-1 : APPLICATION EXAMPLE OF SSD1305T6R1	65

FIGURE 15-1 SSD1305Z DIE TRAY INFORMATION 66
FIGURE 15-2 SSD1305T6R1 DETAIL DIMENSION 67
FIGURE 15-3 SSD1305T7R1 DETAIL DIMENSION 69
FIGURE 15-4 SSD1305Z3 DIE TRAY INFORMATION 70

1 GENERAL DESCRIPTION

The SSD1305 is a CMOS OLED/PLED driver with controller for organic/polymer light emitting diode dot-matrix graphic display system. It consists of 132 segments and 64 commons that can support a maximum display resolution of 132x64. There are 4-color selections to support monochrome or area color OLED/PLED. This IC is designed for Common Cathode type OLED panel.

The SSD1305 embeds with contrast control, display RAM and oscillator, which reduces the number of external components and power consumption. It has 256-step brightness control and separate power for I/O interface logic. It is suitable for many compact portable applications, such as mobile phone sub-display, calculator and MP3 player, etc.

2 FEATURES

- Resolution: 132 x 64 dot matrix panel
- Area color support with 4 Color Selection and 64 steps per color
- Power supply:
 - $V_{DD} = 2.4V$ to $3.5V$ for IC logic
 - $V_{CC} = 7.0V$ to $15.0V$ for Panel driving
 - $V_{DDIO} = 1.6V$ to V_{DD} for MCU interface
- Segment maximum source current: 320uA
- Common maximum sink current: 45mA
- Embedded 132 x 64 bit SRAM display buffer
- 256-step Contrast Control
- 8-bit 6800-series Parallel Interface, 8-bit 8080-series Parallel Interface, Serial Peripheral Interface, I²C Interface
- Row Re-mapping and Column Re-mapping
- Continuous Horizontal, Vertical and Diagonal Scrolling
- Dim Mode operations
- Programmable Frame Frequency and Multiplexing Ratio
- On-Chip Oscillator
- Low power consumption
- Wide range of operating temperatures: -40 to 85 °C

3 ORDERING INFORMATION

Table 3-1 : Ordering Information

Ordering Part Number	SEG	COM	Package Form	Reference	Remark
SSD1305Z	132	64	Gold Bump Die	Page 10, 66	<ul style="list-style-type: none"> • Min SEG pad pitch: 52um • Min COM pad pitch: 45um
SSD1305T6R1	132	64	TAB	Page 13 ,67	<ul style="list-style-type: none"> • 35mm film, 4 sprocket hole • Folding TAB • 8-bit 80 / 8-bit 68 / SPI / I²C interface • SEG lead pitch 0.120mm x 0.998 =0.11976mm • COM lead pitch 0.120mm x 0.998 =0.11976mm
SSD1305T7R1	132	64	TAB	Page 15, 69	<ul style="list-style-type: none"> • 35mm film, 4 sprocket hole • Folding TAB • 8-bit 80 / 8-bit 68 / SPI / I²C interface • SEG lead pitch 0.120mm x 0.998 =0.11976mm • COM lead pitch 0.120mm x 0.998 =0.11976mm
SSD1305Z3	132	64	Gold Bump Die	Page 70	<ul style="list-style-type: none"> • Die Thickness : 300 um ± 25 um

4 BLOCK DIAGRAM

Figure 4-1 : SSD1305 Block Diagram

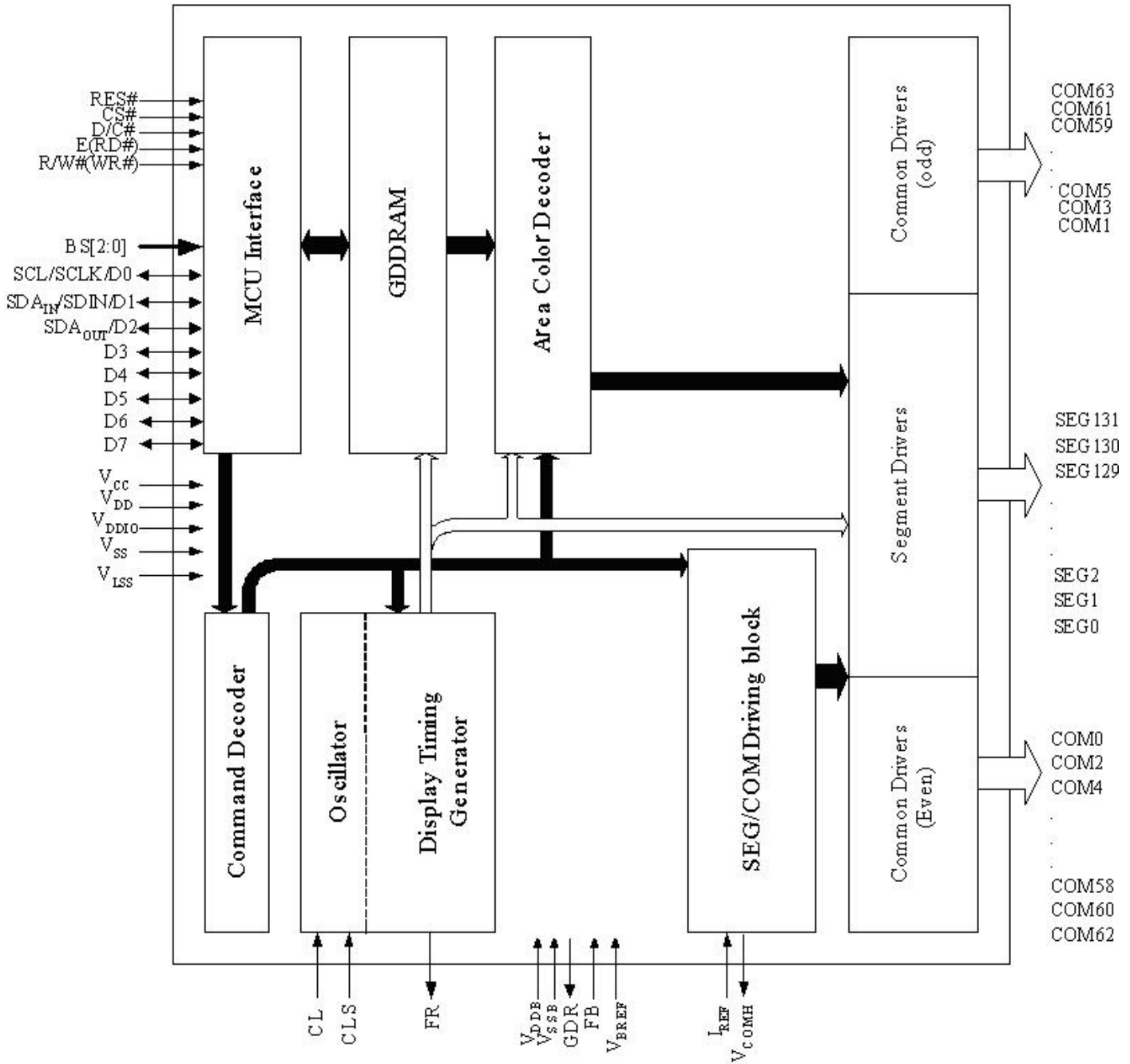

5 DIE PAD FLOOR PLAN

Figure 5-1 : SSD1305Z Die Drawing

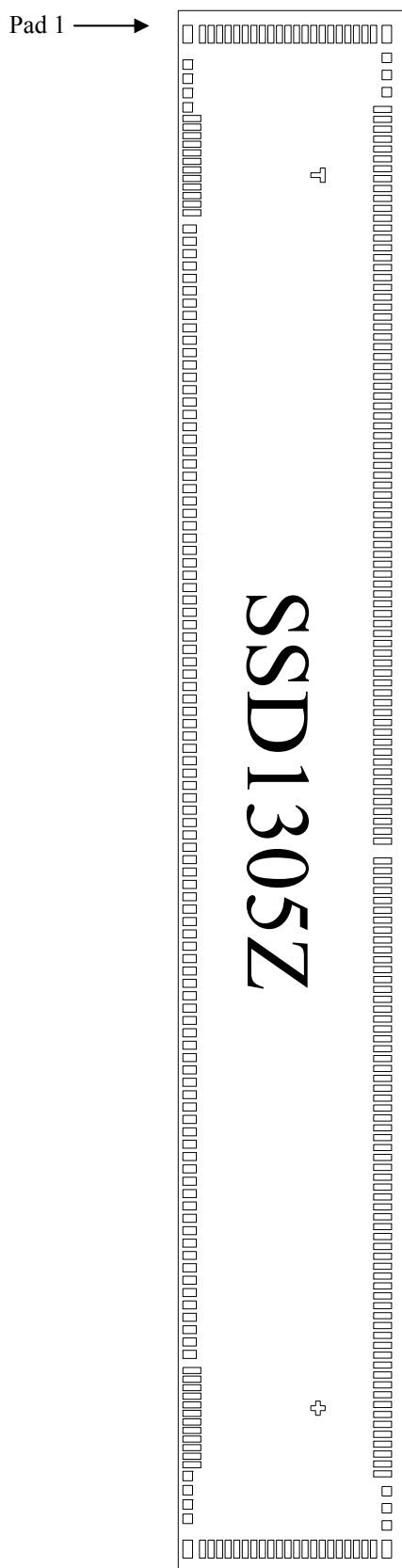

Alignment marks

(For details dimension please see p.9)

	Position	Size
T shape	(-3240, 139)	75um x 75um
+ shape	(3240, 139)	75um x 75um

Die Size	8.2mm x 1.2mm
Die Thickness	457 um ± 25 um
Min I/O pad pitch	65 um
Min SEG pad pitch	52 um
Min COM pad pitch	45 um
Bump Height	Nominal 15 um

Bump Size		
Pad #	X [um]	Y [um]
1, 126, 148, 293	94	50
18-109	42	70
2-5, 122-125, 149-151, 290-292	50	50
6-17, 110-121, 152-289	32	94
127-147, 294-314	94	32

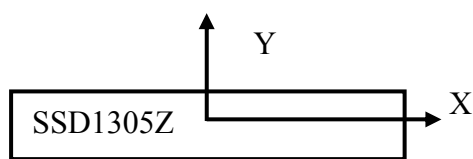

Pad 1,2,3,...->126
Gold Bumps face up

Figure 5-2 : SSD1305Z Alignment Marks Dimension

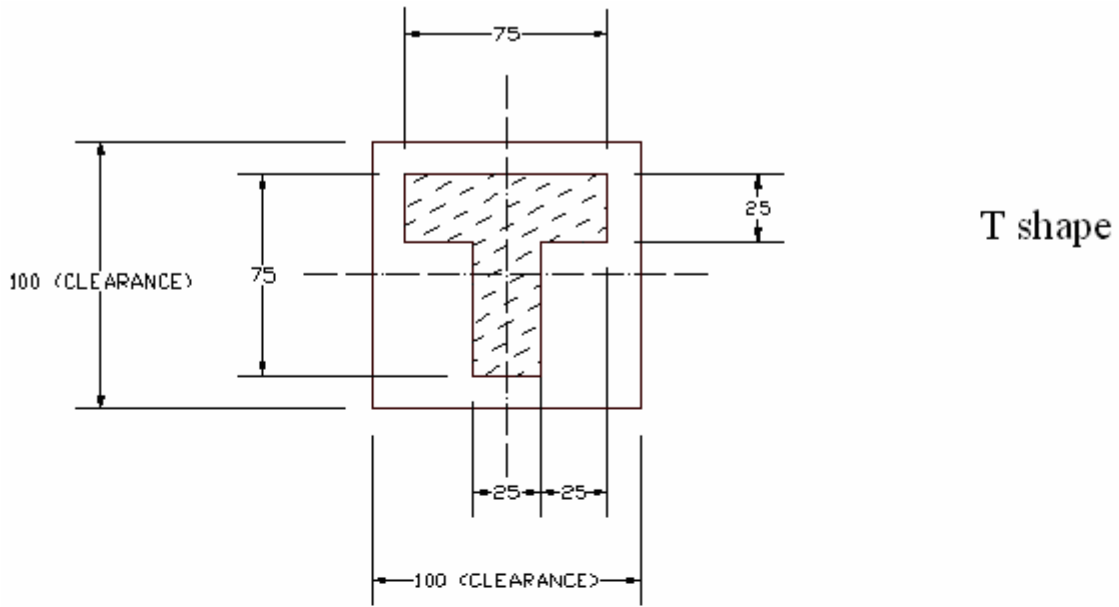

T shape

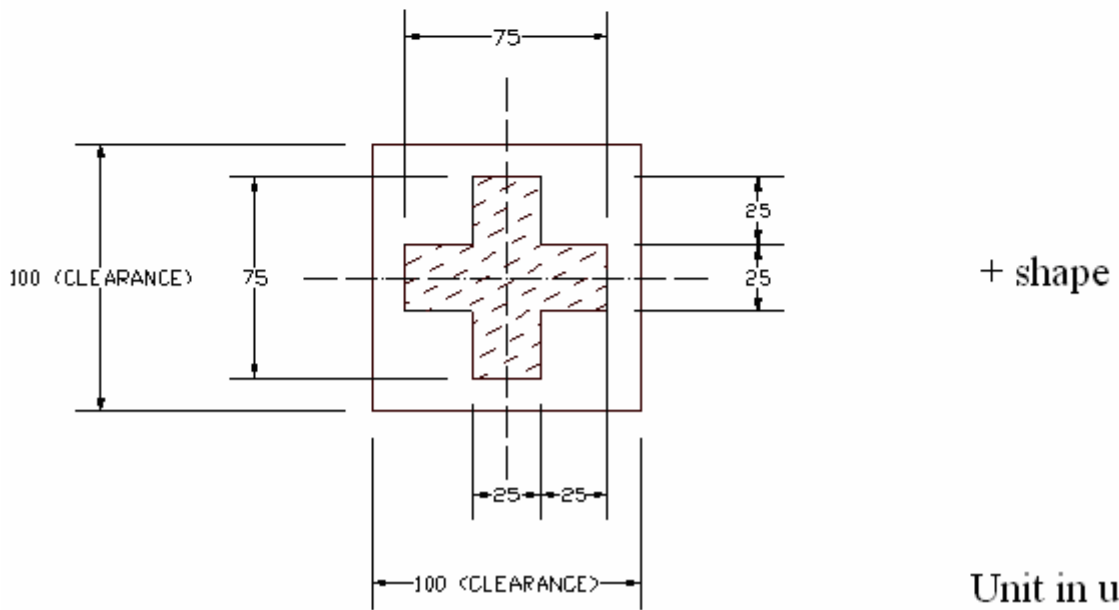

+ shape

Unit in um

Table 5-1 : SSD1305Z Bump Die Pad Coordinates

Pad no.	Pad Name	X-pos	Y-pos	Pad no.	Pad Name	X-pos	Y-pos	Pad no.	Pad Name	X-pos	Y-pos	Pad no.	Pad Name	X-pos	Y-pos
1	NC	-3980.5	-546.0	81	VDDIO	1137.5	-536.0	161	SEG6	3117.6	479.1	241	SEG86	-1091.2	479.1
2	NC	-3821.5	-546.0	82	D0	1202.5	-536.0	162	SEG7	3065.7	479.1	242	SEG87	-1143.1	479.1
3	NC	-3746.5	-546.0	83	D1	1267.5	-536.0	163	SEG8	3013.7	479.1	243	SEG88	-1195.1	479.1
4	NC	-3671.5	-546.0	84	D2	1332.5	-536.0	164	SEG9	2961.7	479.1	244	SEG89	-1247.0	479.1
5	NC	-3596.5	-546.0	85	D3	1397.5	-536.0	165	SEG10	2909.8	479.1	245	SEG90	-1299.0	479.1
6	COM53	-3537.5	-524.0	86	VSS	1462.5	-536.0	166	SEG11	2857.8	479.1	246	SEG91	-1351.0	479.1
7	COM54	-3492.5	-524.0	87	D4	1527.5	-536.0	167	SEG12	2805.9	479.1	247	SEG92	-1402.9	479.1
8	COM55	-3447.5	-524.0	88	D5	1592.5	-536.0	168	SEG13	2753.9	479.1	248	SEG93	-1454.9	479.1
9	COM56	-3402.5	-524.0	89	D6	1657.5	-536.0	169	SEG14	2701.9	479.1	249	SEG94	-1506.8	479.1
10	COM57	-3357.5	-524.0	90	D7	1722.5	-536.0	170	SEG15	2650.0	479.1	250	SEG95	-1558.8	479.1
11	COM58	-3312.5	-524.0	91	VSS	1787.5	-536.0	171	SEG16	2598.0	479.1	251	SEG96	-1610.8	479.1
12	COM59	-3267.5	-524.0	92	CLS	1852.5	-536.0	172	SEG17	2546.1	479.1	252	SEG97	-1662.7	479.1
13	COM60	-3222.5	-524.0	93	VDDIO	1917.5	-536.0	173	SEG18	2494.1	479.1	253	SEG98	-1714.7	479.1
14	COM61	-3177.5	-524.0	94	VDDIO	1982.5	-536.0	174	SEG19	2442.1	479.1	254	SEG99	-1766.6	479.1
15	COM62	-3132.5	-524.0	95	VDD	2047.5	-536.0	175	SEG20	2390.2	479.1	255	SEG100	-1818.6	479.1
16	COM63	-3087.5	-524.0	96	VDD	2112.5	-536.0	176	SEG21	2338.2	479.1	256	SEG101	-1870.6	479.1
17	NC	-3042.5	-524.0	97	VDD	2177.5	-536.0	177	SEG22	2286.3	479.1	257	SEG102	-1922.5	479.1
18	NC	-2957.5	-536.0	98	IREF	2242.5	-536.0	178	SEG23	2234.3	479.1	258	SEG103	-1974.5	479.1
19	VCC	-2892.5	-536.0	99	VCOMH	2307.5	-536.0	179	SEG24	2182.3	479.1	259	SEG104	-2026.4	479.1
20	VCC	-2827.5	-536.0	100	VCC	2372.5	-536.0	180	SEG25	2130.4	479.1	260	SEG105	-2078.4	479.1
21	VCC	-2762.5	-536.0	101	VCC	2437.5	-536.0	181	SEG26	2078.4	479.1	261	SEG106	-2130.4	479.1
22	VCOMH	-2697.5	-536.0	102	VCC	2502.5	-536.0	182	SEG27	2026.5	479.1	262	SEG107	-2182.3	479.1
23	VLSS	-2632.5	-536.0	103	VCC	2567.5	-536.0	183	SEG28	1974.5	479.1	263	SEG108	-2234.3	479.1
24	VLSS	-2567.5	-536.0	104	VCC	2632.5	-536.0	184	SEG29	1922.5	479.1	264	SEG109	-2286.2	479.1
25	VLSS	-2502.5	-536.0	105	VCC	2697.5	-536.0	185	SEG30	1870.6	479.1	265	SEG110	-2338.2	479.1
26	VSS	-2437.5	-536.0	106	VLSS	2762.5	-536.0	186	SEG31	1818.6	479.1	266	SEG111	-2390.2	479.1
27	VSS	-2372.5	-536.0	107	VLSS	2827.5	-536.0	187	SEG32	1766.7	479.1	267	SEG112	-2442.1	479.1
28	TR11	-2307.5	-536.0	108	VLSS	2892.5	-536.0	188	SEG33	1714.7	479.1	268	SEG113	-2494.1	479.1
29	TR10	-2242.5	-536.0	109	NC	2957.5	-536.0	189	SEG34	1662.7	479.1	269	SEG114	-2546.0	479.1
30	TR9	-2177.5	-536.0	110	NC	3042.5	-524.0	190	SEG35	1610.8	479.1	270	SEG115	-2598.0	479.1
31	TR8	-2112.5	-536.0	111	COM31	3087.5	-524.0	191	SEG36	1558.8	479.1	271	SEG116	-2650.0	479.1
32	TR7	-2047.5	-536.0	112	COM30	3132.5	-524.0	192	SEG37	1506.9	479.1	272	SEG117	-2701.9	479.1
33	TR6	-1982.5	-536.0	113	COM29	3177.5	-524.0	193	SEG38	1454.9	479.1	273	SEG118	-2753.9	479.1
34	VSS	-1917.5	-536.0	114	COM28	3222.5	-524.0	194	SEG39	1402.9	479.1	274	SEG119	-2805.8	479.1
35	TR5	-1852.5	-536.0	115	COM27	3267.5	-524.0	195	SEG40	1351.0	479.1	275	SEG120	-2857.8	479.1
36	TR4	-1787.5	-536.0	116	COM26	3312.5	-524.0	196	SEG41	1299.0	479.1	276	SEG121	-2909.8	479.1
37	TR3	-1722.5	-536.0	117	COM25	3357.5	-524.0	197	SEG42	1247.1	479.1	277	SEG122	-2961.7	479.1
38	TR2	-1657.5	-536.0	118	COM24	3402.5	-524.0	198	SEG43	1195.1	479.1	278	SEG123	-3013.7	479.1
39	TR1	-1592.5	-536.0	119	COM23	3447.5	-524.0	199	SEG44	1143.1	479.1	279	SEG124	-3065.6	479.1
40	TR0	-1527.5	-536.0	120	COM22	3492.5	-524.0	200	SEG45	1091.2	479.1	280	SEG125	-3117.6	479.1
41	VSS	-1462.5	-536.0	121	COM21	3537.5	-524.0	201	SEG46	1039.2	479.1	281	SEG126	-3169.6	479.1
42	VSSB	-1397.5	-536.0	122	NC	3596.5	-546.0	202	SEG47	987.3	479.1	282	SEG127	-3221.5	479.1
43	GDR	-1332.5	-536.0	123	NC	3671.5	-546.0	203	SEG48	935.3	479.1	283	SEG128	-3273.5	479.1
44	GDR	-1267.5	-536.0	124	NC	3746.5	-546.0	204	SEG49	883.3	479.1	284	SEG129	-3325.4	479.1
45	VDDB	-1202.5	-536.0	125	NC	3821.5	-546.0	205	SEG50	831.4	479.1	285	SEG130	-3377.4	479.1
46	VDDB	-1137.5	-536.0	126	NC	3900.5	-546.0	206	SEG51	779.4	479.1	286	SEG131	-3429.4	479.1
47	VDDB	-1072.5	-536.0	127	COM20	3980.5	-468.4	207	SEG52	727.5	479.1	287	NC	-3481.3	479.1
48	FB	-1007.5	-536.0	128	COM19	3980.5	-423.4	208	SEG53	675.5	479.1	288	NC	-3533.3	479.1
49	VBREF	-942.5	-536.0	129	COM18	3980.5	-378.4	209	SEG54	623.5	479.1	289	NC	-3585.2	479.1
50	BGGND	-877.5	-536.0	130	COM17	3980.5	-333.4	210	SEG55	571.6	479.1	290	NC	-3637.2	501.1
51	VSS	-812.5	-536.0	131	COM16	3980.5	-288.4	211	SEG56	519.6	479.1	291	NC	-3689.2	501.1
52	VDDB	-747.5	-536.0	132	COM15	3980.5	-243.4	212	SEG57	467.7	479.1	292	NC	-3741.2	501.1
53	VCIR	-682.5	-536.0	133	COM14	3980.5	-198.4	213	SEG58	415.7	479.1	293	NC	-3793.2	501.1
54	VCIR	-617.5	-536.0	134	COM13	3980.5	-153.4	214	SEG59	363.7	479.1	294	COM32	-3980.5	431.6
55	VDD	-552.5	-536.0	135	COM12	3980.5	-108.4	215	SEG60	259.8	479.1	295	COM33	-3980.5	386.6
56	VDD	-487.5	-536.0	136	COM11	3980.5	-63.4	216	SEG61	207.9	479.1	296	COM34	-3980.5	341.6
57	VDD	-422.5	-536.0	137	COM10	3980.5	-18.4	217	SEG62	155.9	479.1	297	COM35	-3980.5	296.6
58	VDD	-357.5	-536.0	138	COM9	3980.5	26.6	218	SEG63	103.9	479.1	298	COM36	-3980.5	251.6
59	VDDIO	-292.5	-536.0	139	COM8	3980.5	71.6	219	SEG64	52.0	479.1	299	COM37	-3980.5	206.6
60	VDDIO	-227.5	-536.0	140	COM7	3980.5	116.6	220	SEG65	0.0	479.1	300	COM38	-3980.5	161.6
61	VDDIO	-162.5	-536.0	141	COM6	3980.5	161.6	221	SEG66	-52.0	479.1	301	COM39	-3980.5	116.6
62	VCC	-97.5	-536.0	142	COM5	3980.5	206.6	222	SEG67	-103.9	479.1	302	COM40	-3980.5	71.6
63	VCC	-32.5	-536.0	143	COM4	3980.5	251.6	223	SEG68	-155.9	479.1	303	COM41	-3980.5	26.6
64	VCC	32.5	-536.0	144	COM3	3980.5	296.6	224	SEG69	-207.8	479.1	304	COM42	-3980.5	-18.4
65	VDDIO	97.5	-536.0	145	COM2	3980.5	341.6	225	SEG70	-259.8	479.1	305	COM43	-3980.5	-63.4
66	BS0	162.5	-536.0	146	COM1	3980.5	386.6	226	SEG71	-311.8	479.1	306	COM44	-3980.5	-108.4
67	VSS	227.5	-536.0	147	COM0	3980.5	431.6	227	SEG72	-363.7	479.1	307	COM45	-3980.5	-153.4
68	BS1	292.5	-536.0	148	NC	3980.5	501.1	228	SEG73	-415.7	479.1	308	COM46	-3980.5	-198.4
69	VDDIO	357.5	-536.0	149	NC	3856.5	501.1	229	SEG74	-467.6	479.1	309	COM47	-3980.5	-243.4
70	BS2	422.5	-536.0	150	NC	3766.5	501.1	230	SEG75	-519.6	479.1	310	COM48	-3980.5	-288.4
71	VSS	487.5	-536.0	151	NC	3676.5	501.1	231	SEG76	-571.6	479.1	311	COM49	-3980.5	-333.4
72	FR	552.5	-536.0	152	NC	3585.2	479.1	232	SEG77	-623.5	479.1	312	COM50	-3980.5	-378.4
73	CL	617.5	-536.0	153	NC	3533.3	479.1	233	SEG78	-675.5	479.1	313	COM51	-3980.5	-423.4
74	VSS	682.5	-536.0	154	NC	3481.3	479.1	234	SEG79	-727.4	479.1	314	COM52	-3980.5	-468.4
75	CS#	747.5	-536.0	155	SEG0	3429.4	479.1	235	SEG80	-779.4	479.1				
76	RES#	812.5	-536.0	156	SEG1	3377.4	479.1	236	SEG81	-831.4	479.1				
77	D/C#	877.5	-536.0	157	SEG2	3325.4	479.1	237	SEG82	-883.3	479.1				
78	VSS	942.5	-536.0	158	SEG3	3273.5	479.1	238	SEG83	-935.3	479.1				
79	R/W#(WR#)	1007.5	-536.0	159	SEG4	3221.5	479.1	239	SEG84	-987.2	479.1				
80	E(RD#)	1072.5	-536.0	160	SEG5	3169.6	479.1	240	SEG85	-1039.2	479.1				

6 PIN ARRANGEMENT

6.1 SSD1305T6R1 pin assignment

Figure 6-1 : SSD1305T6R1 Pin Assignment

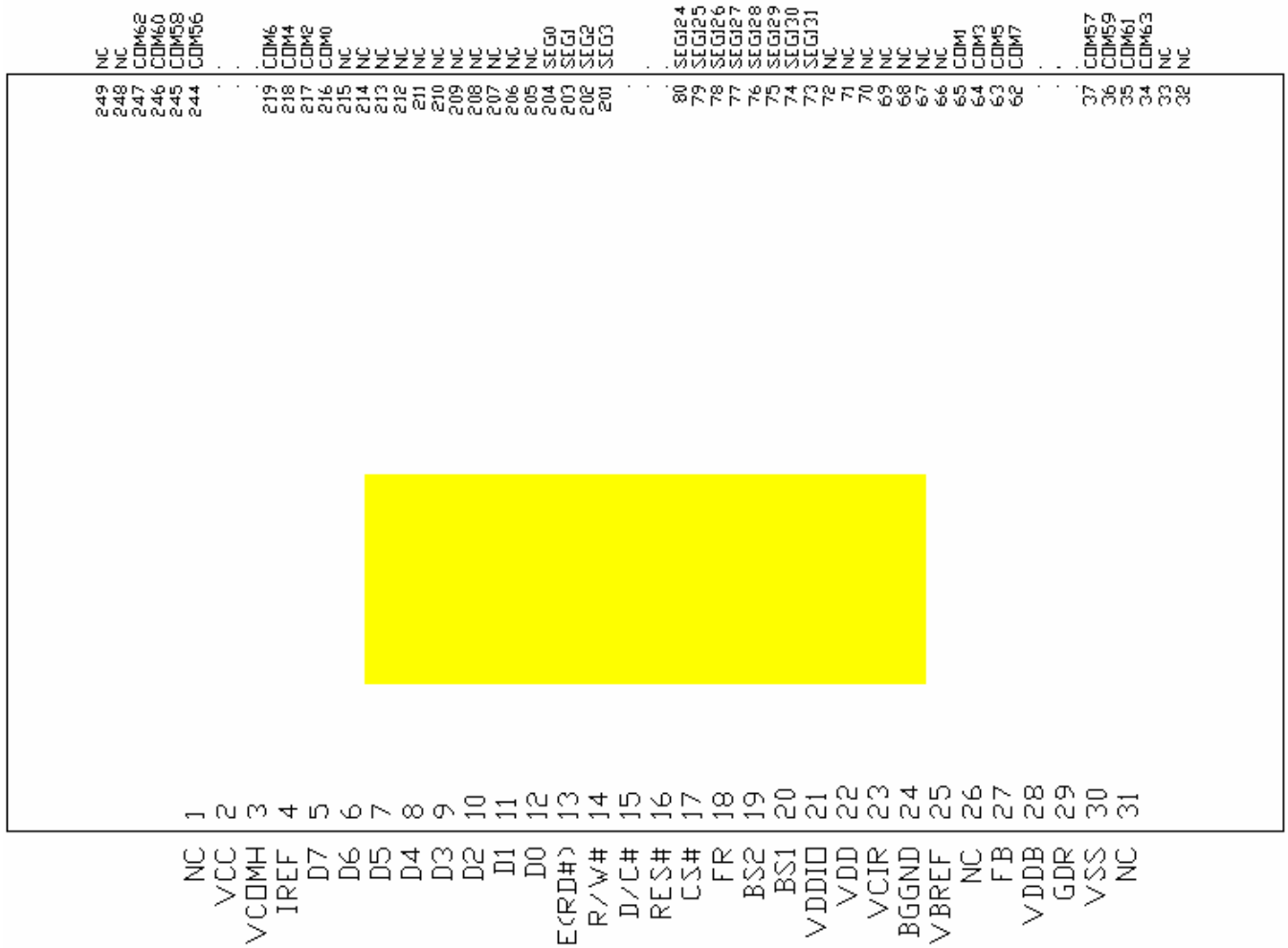

Table 6-1 : SSD1305T6R1 Pin Assignment Table

Pin#	Name	Pin#	Name	Pin#	Name	Pin#	Name
1	NC	81	SEG123	161	SEG43	241	COM50
2	VCC	82	SEG122	162	SEG42	242	COM52
3	VCOMH	83	SEG121	163	SEG41	243	COM54
4	IREF	84	SEG120	164	SEG40	244	COM56
5	D7	85	SEG119	165	SEG39	245	COM58
6	D6	86	SEG118	166	SEG38	246	COM60
7	D5	87	SEG117	167	SEG37	247	COM62
8	D4	88	SEG116	168	SEG36	248	NC
9	D3	89	SEG115	169	SEG35	249	NC
10	D2	90	SEG114	170	SEG34		
11	D1	91	SEG113	171	SEG33		
12	D0	92	SEG112	172	SEG32		
13	E(RD#)	93	SEG111	173	SEG31		
14	R/W#	94	SEG110	174	SEG30		
15	D/C#	95	SEG109	175	SEG29		
16	RES#	96	SEG108	176	SEG28		
17	CS#	97	SEG107	177	SEG27		
18	FR	98	SEG106	178	SEG26		
19	BS2	99	SEG105	179	SEG25		
20	BS1	100	SEG104	180	SEG24		
21	VDDIO	101	SEG103	181	SEG23		
22	VDD	102	SEG102	182	SEG22		
23	VCIR	103	SEG101	183	SEG21		
24	BGGND	104	SEG100	184	SEG20		
25	VBREF	105	SEG99	185	SEG19		
26	NC	106	SEG98	186	SEG18		
27	FB	107	SEG97	187	SEG17		
28	VDDB	108	SEG96	188	SEG16		
29	GDR	109	SEG95	189	SEG15		
30	VSS	110	SEG94	190	SEG14		
31	NC	111	SEG93	191	SEG13		
32	NC	112	SEG92	192	SEG12		
33	NC	113	SEG91	193	SEG11		
34	COM63	114	SEG90	194	SEG10		
35	COM61	115	SEG89	195	SEG9		
36	COM59	116	SEG88	196	SEG8		
37	COM57	117	SEG87	197	SEG7		
38	COM55	118	SEG86	198	SEG6		
39	COM53	119	SEG85	199	SEG5		
40	COM51	120	SEG84	200	SEG4		
41	COM49	121	SEG83	201	SEG3		
42	COM47	122	SEG82	202	SEG2		
43	COM45	123	SEG81	203	SEG1		
44	COM43	124	SEG80	204	SEG0		
45	COM41	125	SEG79	205	NC		
46	COM39	126	SEG78	206	NC		
47	COM37	127	SEG77	207	NC		
48	COM35	128	SEG76	208	NC		
49	COM33	129	SEG75	209	NC		
50	COM31	130	SEG74	210	NC		
51	COM29	131	SEG73	211	NC		
52	COM27	132	SEG72	212	NC		
53	COM25	133	SEG71	213	NC		
54	COM23	134	SEG70	214	NC		
55	COM21	135	SEG69	215	NC		
56	COM19	136	SEG68	216	COM0		
57	COM17	137	SEG67	217	COM2		
58	COM15	138	SEG66	218	COM4		
59	COM13	139	SEG65	219	COM6		
60	COM11	140	SEG64	220	COM8		
61	COM9	141	SEG63	221	COM10		
62	COM7	142	SEG62	222	COM12		
63	COM5	143	SEG61	223	COM14		
64	COM3	144	SEG60	224	COM16		
65	COM1	145	SEG59	225	COM18		
66	NC	146	SEG58	226	COM20		
67	NC	147	SEG57	227	COM22		
68	NC	148	SEG56	228	COM24		
69	NC	149	SEG55	229	COM26		
70	NC	150	SEG54	230	COM28		
71	NC	151	SEG53	231	COM30		
72	NC	152	SEG52	232	COM32		
73	SEG131	153	SEG51	233	COM34		
74	SEG130	154	SEG50	234	COM36		
75	SEG129	155	SEG49	235	COM38		
76	SEG128	156	SEG48	236	COM40		
77	SEG127	157	SEG47	237	COM42		
78	SEG126	158	SEG46	238	COM44		
79	SEG125	159	SEG45	239	COM46		
80	SEG124	160	SEG44	240	COM48		

6.2 SSD1305T7R1 pin assignment

Figure 6-2 : SSD1305T7R1 Pin Assignment

1	NC	249	NC
2	VCC	248	NC
3	VCOMH	247	COM62
4	IREF	246	COM60
5	D7	245	COM58
6	D6	244	COM56
7	D5	219	COM6
8	D4	218	COM4
9	D3	217	COM2
10	D2	216	COM0
11	D1	215	NC
12	D0	214	NC
13	E/RD#	213	NC
14	R/W#	212	NC
15	D/C#	211	NC
16	RES#	210	NC
17	CS#	209	NC
18	NC	208	NC
19	BS2	207	NC
20	BS1	206	NC
21	VDD	205	NC
22	NC	204	SEG0
23	NC	203	SEG1
24	NC	202	SEG2
25	VBREF	201	SEG3
26	NC	80	SEG124
27	FB	79	SEG125
28	VDDDB	78	SEG126
29	GDR	77	SEG127
30	VSS	76	SEG128
31	NC	75	SEG129
		74	SEG130
		73	SEG131
		72	NC
		71	NC
		70	NC
		69	NC
		68	NC
		67	NC
		66	NC
		65	COM1
		64	COM3
		63	COM5
		62	COM7
		37	COM57
		36	COM59
		35	COM61
		34	COM63
		33	NC
		32	NC

Table 6-2 : SSD1305T7R1 Pin Assignment

Pin #	Name	Pin #	Name	Pin #	Name	Pin #	Name
1	NC	81	SEG123	161	SEG43	241	COM50
2	VCC	82	SEG122	162	SEG42	242	COM52
3	VCOMH	83	SEG121	163	SEG41	243	COM54
4	IREF	84	SEG120	164	SEG40	244	COM56
5	D7	85	SEG119	165	SEG39	245	COM58
6	D6	86	SEG118	166	SEG38	246	COM60
7	D5	87	SEG117	167	SEG37	247	COM62
8	D4	88	SEG116	168	SEG36	248	NC
9	D3	89	SEG115	169	SEG35	249	NC
10	D2	90	SEG114	170	SEG34		
11	D1	91	SEG113	171	SEG33		
12	D0	92	SEG112	172	SEG32		
13	E/RD#	93	SEG111	173	SEG31		
14	R/W#	94	SEG110	174	SEG30		
15	D/C#	95	SEG109	175	SEG29		
16	RES#	96	SEG108	176	SEG28		
17	CS#	97	SEG107	177	SEG27		
18	NC	98	SEG106	178	SEG26		
19	BS2	99	SEG105	179	SEG25		
20	BS1	100	SEG104	180	SEG24		
21	VDD	101	SEG103	181	SEG23		
22	NC	102	SEG102	182	SEG22		
23	NC	103	SEG101	183	SEG21		
24	NC	104	SEG100	184	SEG20		
25	VBREF	105	SEG99	185	SEG19		
26	NC	106	SEG98	186	SEG18		
27	FB	107	SEG97	187	SEG17		
28	VDDB	108	SEG96	188	SEG16		
29	GDR	109	SEG95	189	SEG15		
30	VSS	110	SEG94	190	SEG14		
31	NC	111	SEG93	191	SEG13		
32	NC	112	SEG92	192	SEG12		
33	NC	113	SEG91	193	SEG11		
34	COM63	114	SEG90	194	SEG10		
35	COM61	115	SEG89	195	SEG9		
36	COM59	116	SEG88	196	SEG8		
37	COM57	117	SEG87	197	SEG7		
38	COM55	118	SEG86	198	SEG6		
39	COM53	119	SEG85	199	SEG5		
40	COM51	120	SEG84	200	SEG4		
41	COM49	121	SEG83	201	SEG3		
42	COM47	122	SEG82	202	SEG2		
43	COM45	123	SEG81	203	SEG1		
44	COM43	124	SEG80	204	SEG0		
45	COM41	125	SEG79	205	NC		
46	COM39	126	SEG78	206	NC		
47	COM37	127	SEG77	207	NC		
48	COM35	128	SEG76	208	NC		
49	COM33	129	SEG75	209	NC		
50	COM31	130	SEG74	210	NC		
51	COM29	131	SEG73	211	NC		
52	COM27	132	SEG72	212	NC		
53	COM25	133	SEG71	213	NC		
54	COM23	134	SEG70	214	NC		
55	COM21	135	SEG69	215	NC		
56	COM19	136	SEG68	216	COM0		
57	COM17	137	SEG67	217	COM2		
58	COM15	138	SEG66	218	COM4		
59	COM13	139	SEG65	219	COM6		
60	COM11	140	SEG64	220	COM8		
61	COM9	141	SEG63	221	COM10		
62	COM7	142	SEG62	222	COM12		
63	COM5	143	SEG61	223	COM14		
64	COM3	144	SEG60	224	COM16		
65	COM1	145	SEG59	225	COM18		
66	NC	146	SEG58	226	COM20		
67	NC	147	SEG57	227	COM22		
68	NC	148	SEG56	228	COM24		
69	NC	149	SEG55	229	COM26		
70	NC	150	SEG54	230	COM28		
71	NC	151	SEG53	231	COM30		
72	NC	152	SEG52	232	COM32		
73	SEG131	153	SEG51	233	COM34		
74	SEG130	154	SEG50	234	COM36		
75	SEG129	155	SEG49	235	COM38		
76	SEG128	156	SEG48	236	COM40		
77	SEG127	157	SEG47	237	COM42		
78	SEG126	158	SEG46	238	COM44		
79	SEG125	159	SEG45	239	COM46		
80	SEG124	160	SEG44	240	COM48		

7 PIN DESCRIPTION

Key: I = Input, O =Output, IO = Bi-directional (input/output), P = Power pin

Table 7-1 : Pin Description

Pin Name	Pin Type	Description
V _{DD}	P	Power supply pin for core logic operation.
V _{DDIO}	P	Power supply for interface logic level. It should be match with MCU interface voltage level. V _{DDIO} must always be equal or lower than V _{DD} .
V _{CC}	P	Power supply for panel driving voltage. This is also the most positive power voltage supply pin.
V _{SS}	P	This is a ground pin.
V _{LSS}	P	This is an analog ground pin. It should be connected to V _{SS} externally.
V _{COMH}	O	The pin for COM signal deselected voltage level. A capacitor should be connected between this pin and V _{SS} .
BGGND	P	This pin must be connected to ground.
V _{DDB}	P	This is a reserved pin. It must be connected to V _{DD} .
V _{SSB}	P	This is a reserved pin. It must be connected to V _{SS} .
GDR	O	This is a reserved pin. It should be kept NC (i.e. Float during normal operation).
FB	I	This is a reserved pin. It should be kept NC (i.e. Float during normal operation).
V _{BREF}	P	This is a reserved pin. It should be kept NC (i.e. Float during normal operation).
V _{CIR}	O	This is a reserved pin. It should be kept NC (i.e. Float during normal operation).
BS[2:0]	I	MCU bus interface selection pins. Please refer to Table 7-2 for the details of setting.
I _{REF}	I	This is segment output current reference pin. A resistor should be connected between this pin and V _{SS} to maintain the I _{REF} current at 10uA. Please refer to Figure 8-18 for the details of resistor value.
FR	O	This pin outputs RAM write synchronization signal. Proper timing between MCU data writing and frame display timing can be achieved to prevent tearing effect. It should be kept NC if it is not used. Please refer to Section 8.4 for details usage.
CL	I	This is external clock input pin. When internal clock is enabled (i.e. HIGH in CLS pin), this pin is not used and should be connected to V _{SS} . When internal clock is disabled (i.e. LOW in CLS pin), this pin is the external clock source input pin.
CLS	I	This is internal clock enable pin. When it is pulled HIGH (i.e. connect to V _{DDIO}), internal clock is enabled. When it is pulled LOW, the internal clock is disabled; an external clock source must be connected to the CL pin for normal operation.
RES#	I	This pin is reset signal input. When the pin is LOW, initialization of the chip is executed. Keep this pin HIGH (i.e. connect to V _{DDIO}) during normal operation.

Pin Name	Pin Type	Description
CS#	I	This pin is the chip select input. (active LOW)
D/C#	I	This is Data/Command control pin. When it is pulled HIGH (i.e. connect to V _{DDIO}), the data at D[7:0] is treated as data. When it is pulled LOW, the data at D[7:0] will be transferred to the command register. In I ² C mode, this pin acts as SA0 for slave address selection. For detail relationship to MCU interface signals, please refer to the Timing Characteristics Diagrams: Figure 13-1 to Figure 13-5.
E (RD#)	I	When interfacing to a 6800-series microprocessor, this pin will be used as the Enable (E) signal. Read/write operation is initiated when this pin is pulled HIGH (i.e. connect to V _{DDIO}) and the chip is selected. When connecting to an 8080-microprocessor, this pin receives the Read (RD#) signal. Read operation is initiated when this pin is pulled LOW and the chip is selected. When serial interface is selected, this pin must be connected to V _{SS} .
R/W#(WR#)	I	This is read / write control input pin connecting to the MCU interface. When interfacing to a 6800-series microprocessor, this pin will be used as Read/Write (R/W#) selection input. Read mode will be carried out when this pin is pulled HIGH (i.e. connect to V _{DDIO}) and write mode when LOW. When 8080 interface mode is selected, this pin will be the Write (WR#) input. Data write operation is initiated when this pin is pulled LOW and the chip is selected. When serial interface is selected, this pin must be connected to V _{SS} .
D[7:0]	IO	These are 8-bit bi-directional data bus to be connected to the microprocessor's data bus. When serial interface mode is selected, D0 will be the serial clock input: SCLK; D1 will be the serial data input: SDIN and D2 should be left opened. When I ² C mode is selected, D2, D1 should be tied together and serve as SDA _{out} , SDA _{in} in application and D0 is the serial clock input, SCL.
TR0-TR11	-	Testing reserved pins. It should be kept NC.
SEG0 ~ SEG131	O	These pins provide Segment switch signals to OLED panel. They are in high impedance stage when display is OFF.
COM0 ~ COM63	O	These pins provide Common switch signals to OLED panel. They are in high impedance state when display is OFF.
NC	-	This is dummy pin. Do not group or short NC pins together.

Table 7-2 : MCU Bus Interface Pin Selection

Pin Name	I ² C Interface	6800-parallel interface (8 bit)	8080-parallel interface (8 bit)	Serial interface
BS0	0	0	0	0
BS1	1	0	1	0
BS2	0	1	1	0

Note

⁽¹⁾ 0 is connected to V_{SS}

⁽²⁾ 1 is connected to V_{DDIO}

8 FUNCTIONAL BLOCK DESCRIPTIONS

8.1 MCU Interface selection

SSD1305 MCU interface consist of 8 data pins and 5 control pins. The pin assignment at different interface mode is summarized in Table 8-1. Different MCU mode can be set by hardware selection on BS[2:0] pins (please refer to Table 7-2 for BS[2:0] setting).

Table 8-1 : MCU interface assignment under different bus interface mode

Pin Name Bus Interface	Data/Command Interface								Control Signal				
	D7	D6	D5	D4	D3	D2	D1	D0	E	R/W#	CS#	D/C#	RES#
8-bit 8080	D[7:0]								RD#	WR#	CS#	D/C#	RES#
8-bit 6800	D[7:0]								E	R/W#	CS#	D/C#	RES#
SPI	Tie LOW				NC	SDIN	SCLK	Tie LOW		CS#	D/C#	RES#	
I ² C	Tie LOW				SDA _{OUT}	SDA _{IN}	SCL	Tie LOW		SA0	RES#		

8.1.1 MCU Parallel 6800-series Interface

The parallel interface consists of 8 bi-directional data pins (D[7:0]), R/W#, D/C#, E and CS#.

A LOW in R/W# indicates WRITE operation and HIGH in R/W# indicates READ operation.
 A LOW in D/C# indicates COMMAND read/write and HIGH in D/C# indicates DATA read/write.
 The E input serves as data latch signal while CS# is LOW. Data is latched at the falling edge of E signal.

Table 8-2 : Control pins of 6800 interface

Function	E	R/W#	CS#	D/C#
Write command	↓	L	L	L
Read status	↓	H	L	L
Write data	↓	L	L	H
Read data	↓	H	L	H

Note

- ⁽¹⁾ ↓ stands for falling edge of signal
- H stands for HIGH in signal
- L stands for LOW in signal

In order to match the operating frequency of display RAM with that of the microprocessor, some pipeline processing is internally performed which requires the insertion of a dummy read before the first actual display data read. This is shown in Figure 8-1.

Figure 8-1 : Data read back procedure - insertion of dummy read

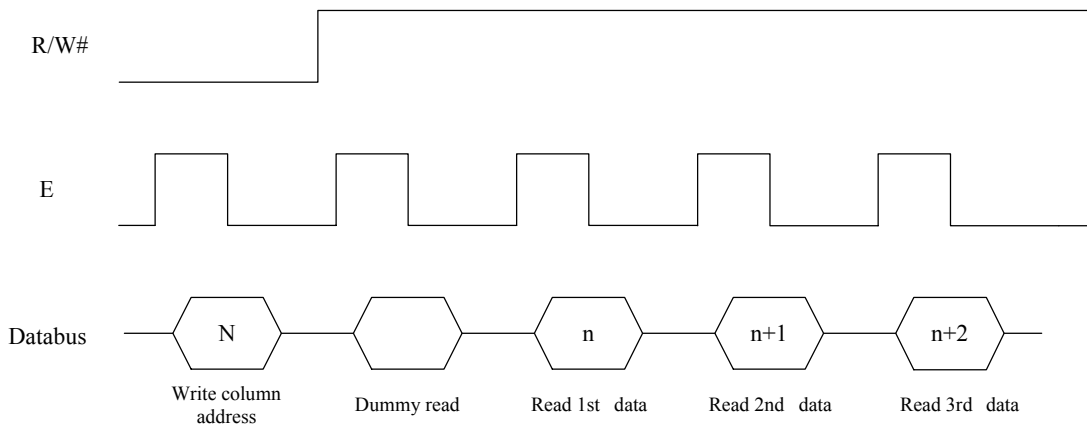

8.1.2 MCU Parallel 8080-series Interface

The parallel interface consists of 8 bi-directional data pins (D[7:0]), RD#, WR#, D/C# and CS#.

A LOW in D/C# indicates COMMAND read/write and HIGH in D/C# indicates DATA read/write.

A rising edge of RD# input serves as a data READ latch signal while CS# is kept LOW.

A rising edge of WR# input serves as a data/command WRITE latch signal while CS# is kept LOW.

Figure 8-2 : Example of Write procedure in 8080 parallel interface mode

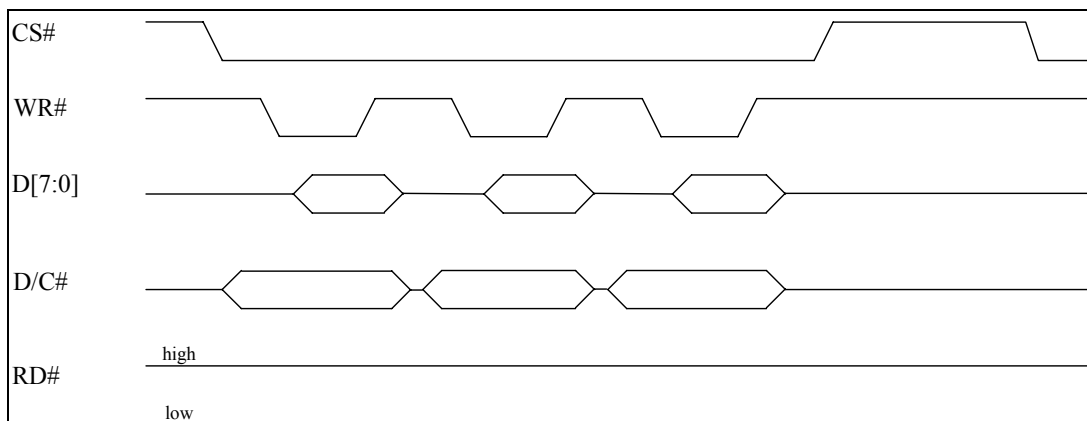

Figure 8-3 : Example of Read procedure in 8080 parallel interface mode

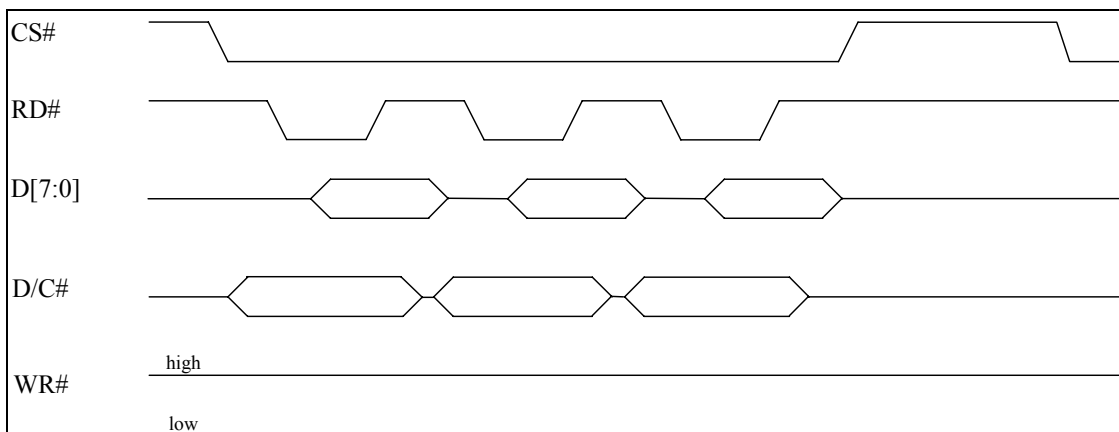

Table 8-3 : Control pins of 8080 interface (Form 1)

Function	RD#	WR#	CS#	D/C#
Write command	H	↑	L	L
Read status	↑	H	L	L
Write data	H	↑	L	H
Read data	↑	H	L	H

Note

- (1) ↑ stands for rising edge of signal
- (2) H stands for HIGH in signal
- (3) L stands for LOW in signal
- (4) Refer to Figure 13-2 for Form 1 8080-Series MPU Parallel Interface Timing Characteristics

Alternatively, RD# and WR# can be keep stable while CS# serves as the data/command latch signal.

Table 8-4 : Control pins of 8080 interface (Form 2)

Function	RD#	WR#	CS#	D/C#
Write command	H	L	↑	L
Read status	L	H	↑	L
Write data	H	L	↑	H
Read data	L	H	↑	H

Note

- (1) ↑ stands for rising edge of signal
- (2) H stands for HIGH in signal
- (3) L stands for LOW in signal
- (4) Refer to Figure 13-3 for Form 2 8080-Series MPU Parallel Interface Timing Characteristics

In order to match the operating frequency of display RAM with that of the microprocessor, some pipeline processing is internally performed which requires the insertion of a dummy read before the first actual display data read. This is shown in Figure 8-4.

Figure 8-4 : Display data read back procedure - insertion of dummy read

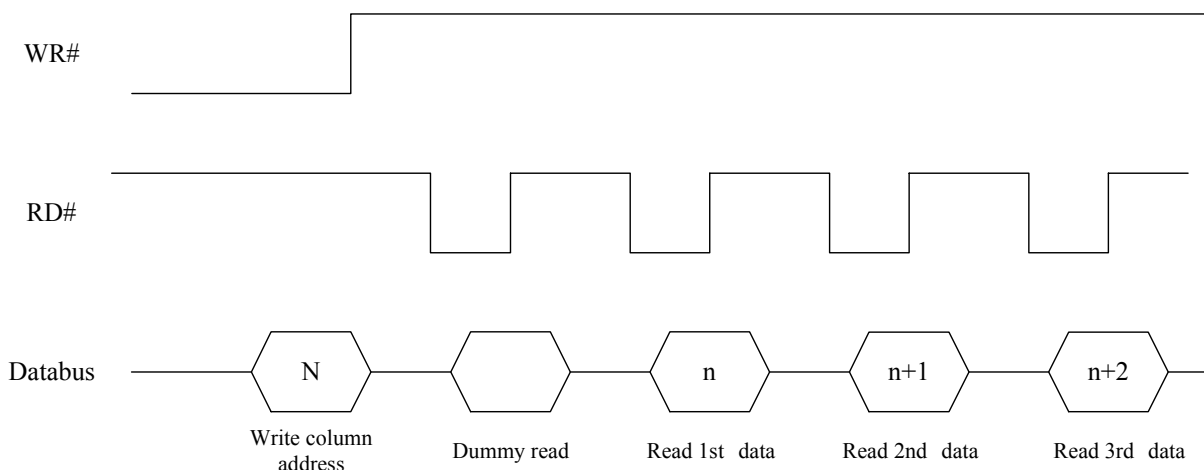

8.1.3 MCU Serial Interface

The serial interface consists of serial clock SCLK, serial data SDIN, D/C#, CS#. In SPI mode, D0 acts as SCLK, D1 acts as SDIN. For the unused data pins, D2 should be left open. The pins from D3 to D7, E and R/W# can be connected to an external ground.

Table 8-5 : Control pins of Serial interface

Function	E(RD#)	R/W#(WR#)	CS#	D/C#	D0	Note
Write command	Tie LOW	Tie LOW	L	L	↑	(1) ↑ stands for rising edge of signal
Write data	Tie LOW	Tie LOW	L	H	↑	(2) H stands for HIGH in signal (3) L stands for LOW in signal

SDIN is shifted into an 8-bit shift register on every rising edge of SCLK in the order of D7, D6, ... D0. D/C# is sampled on every eighth clock and the data byte in the shift register is written to the Graphic Display Data RAM (GDDRAM) or command register in the same clock.

Under serial mode, only write operations are allowed.

Figure 8-5 : Write procedure in SPI mode

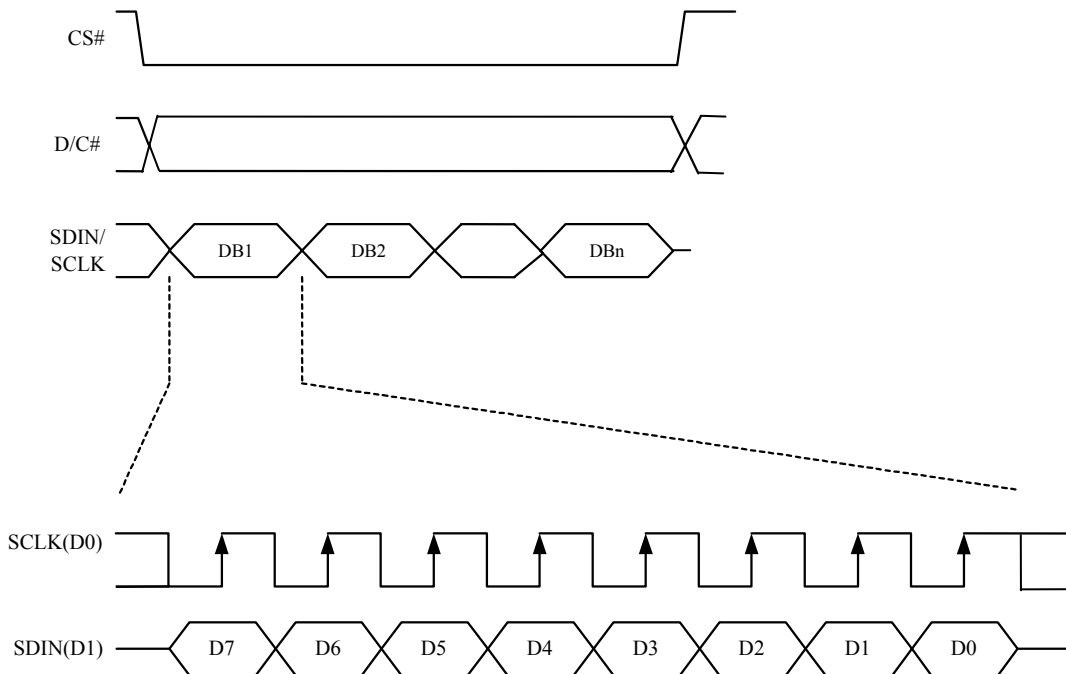

8.1.4 MCU I²C Interface

The I²C communication interface consists of slave address bit SA0, I²C-bus data signal SDA (SDA_{OUT}/D₂ for output and SDA_{IN}/D₁ for input) and I²C-bus clock signal SCL (D₀). Both the data and clock signals must be connected to pull-up resistors. RES# is used for the initialization of device.

a) Slave address bit (SA0)

SSD1305 has to recognize the slave address before transmitting or receiving any information by the I²C-bus. The device will respond to the slave address following by the slave address bit (“SA0” bit) and the read/write select bit (“R/W#” bit) with the following byte format,

b₇ b₆ b₅ b₄ b₃ b₂ b₁ b₀
 0 1 1 1 1 0 SA0 R/W#

“SA0” bit provides an extension bit for the slave address. Either “0111100” or “0111101”, can be selected as the slave address of SSD1305. D/C# pin acts as SA0 for slave address selection.

“R/W#” bit is used to determine the operation mode of the I²C-bus interface. R/W#=1, it is in read mode. R/W#=0, it is in write mode.

b) I²C-bus data signal (SDA)

SDA acts as a communication channel between the transmitter and the receiver. The data and the acknowledgement are sent through the SDA.

It should be noticed that the ITO track resistance and the pulled-up resistance at “SDA” pin becomes a voltage potential divider. As a result, the acknowledgement would not be possible to attain a valid logic 0 level in “SDA”.

“SDA_{IN}” and “SDA_{OUT}” are tied together and serve as SDA. The “SDA_{IN}” pin must be connected to act as SDA. The “SDA_{OUT}” pin may be disconnected. When “SDA_{OUT}” pin is disconnected, the acknowledgement signal will be ignored in the I²C-bus.

c) I²C-bus clock signal (SCL)

The transmission of information in the I²C-bus is following a clock signal, SCL. Each transmission of data bit is taken place during a single clock period of SCL.

8.1.4.1 I²C-bus Write data

The I²C-bus interface gives access to write data and command into the device. Please refer to Figure 8-6 for the write mode of I²C-bus in chronological order.

Figure 8-6 : I²C -bus data format

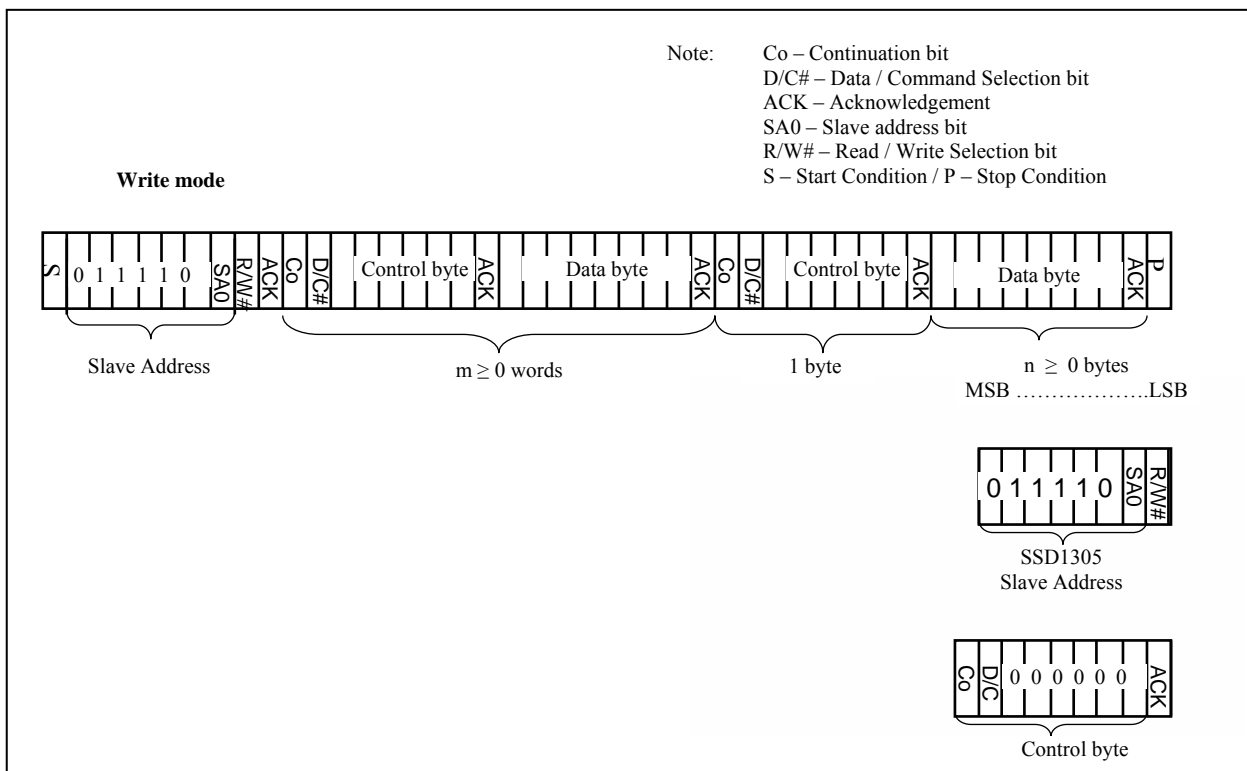

8.1.4.2 Write mode for I²C

- 1) The master device initiates the data communication by a start condition. The definition of the start condition is shown in Figure 8-7. The start condition is established by pulling the SDA from HIGH to LOW while the SCL stays HIGH.
- 2) The slave address is following the start condition for recognition use. For the SSD1305, the slave address is either “b0111100” or “b0111101” by changing the SA0 to LOW or HIGH (D/C pin acts as SA0).
- 3) The write mode is established by setting the R/W# bit to logic “0”.
- 4) An acknowledgement signal will be generated after receiving one byte of data, including the slave address and the R/W# bit. Please refer to the Figure 8-8 for the graphical representation of the acknowledge signal. The acknowledge bit is defined as the SDA line is pulled down during the HIGH period of the acknowledgement related clock pulse.
- 5) After the transmission of the slave address, either the control byte or the data byte may be sent across the SDA. A control byte mainly consists of Co and D/C# bits following by six “0” ‘s.
 - a. If the Co bit is set as logic “0”, the transmission of the following information will contain data bytes only.
 - b. The D/C# bit determines the next data byte is acted as a command or a data. If the D/C# bit is set to logic “0”, it defines the following data byte as a command. If the D/C# bit is set to logic “1”, it defines the following data byte as a data which will be stored at the GDDRAM. The GDDRAM column address pointer will be increased by one automatically after each data write.
- 6) Acknowledge bit will be generated after receiving each control byte or data byte.
- 7) The write mode will be finished when a stop condition is applied. The stop condition is also defined in Figure 8-7. The stop condition is established by pulling the “SDA in” from LOW to HIGH while the “SCL” stays HIGH.

Figure 8-7 : Definition of the Start and Stop Condition

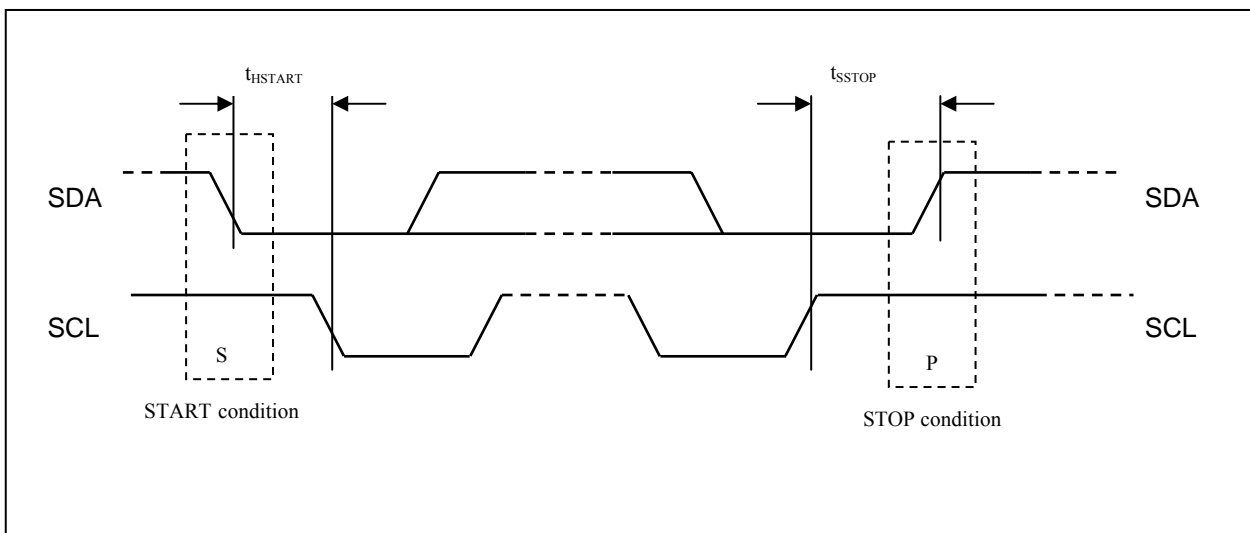
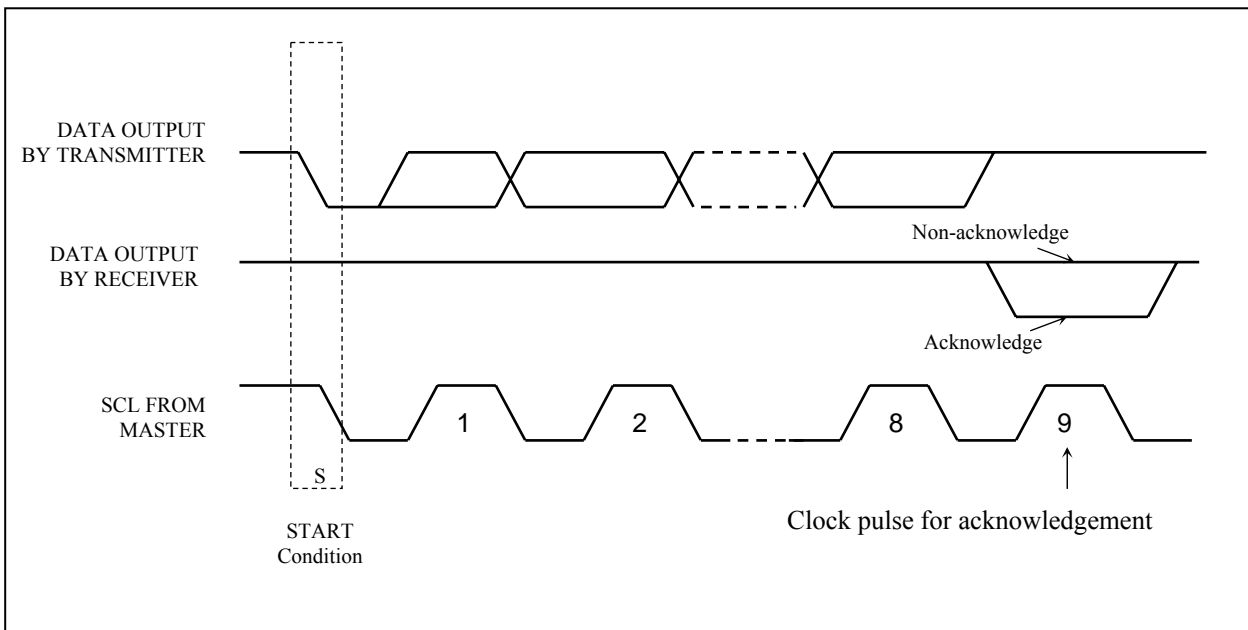

Figure 8-8 : Definition of the acknowledgement condition



Please be noted that the transmission of the data bit has some limitations.

1. The data bit, which is transmitted during each SCL pulse, must keep at a stable state within the “HIGH” period of the clock pulse. Please refer to the Figure 8-9 for graphical representations. Except in start or stop conditions, the data line can be switched only when the SCL is LOW.
2. Both the data line (SDA) and the clock line (SCL) should be pulled up by external resistors.

Figure 8-9 : Definition of the data transfer condition

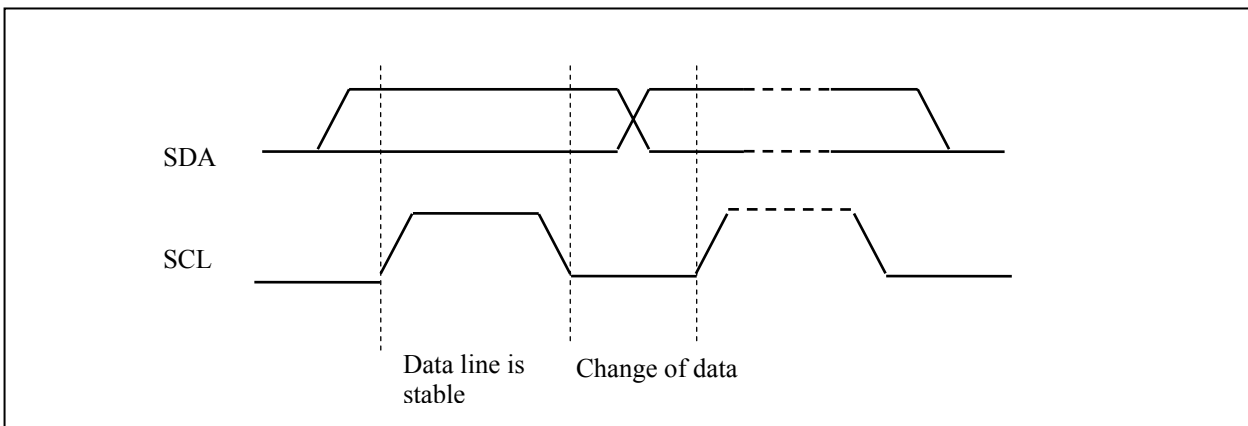

8.2 Command Decoder

This module determines whether the input data is interpreted as data or command. Data is interpreted based upon the input of the D/C# pin.

If D/C# pin is HIGH, D[7:0] is interpreted as display data written to Graphic Display Data RAM (GDDRAM). If it is LOW, the input at D[7:0] is interpreted as a command. Then data input will be decoded and written to the corresponding command register.

8.3 Oscillator Circuit and Display Time Generator

Figure 8-10 : Oscillator Circuit and Display Time Generator

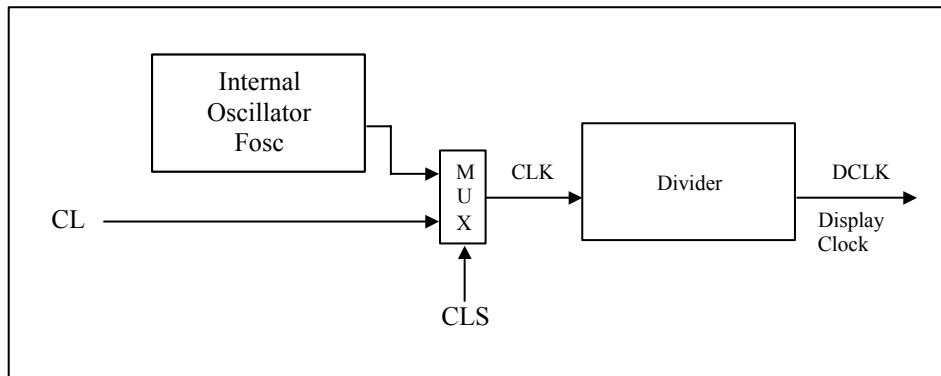

This module is an on-chip LOW power RC oscillator circuitry. The operation clock (CLK) can be generated either from internal oscillator or external source CL pin. This selection is done by CLS pin. If CLS pin is pulled HIGH, internal oscillator is chosen and CL should be connected to V_{SS}. Pulling CLS pin LOW disables internal oscillator and external clock must be connected to CL pins for proper operation. When the internal oscillator is selected, its output frequency F_{osc} can be changed by command D5h A[7:4].

The display clock (DCLK) for the Display Timing Generator is derived from CLK. The division factor “D” can be programmed from 1 to 16 by command D5h

$$DCLK = F_{OSC} / D$$

The frame frequency of display is determined by the following formula.

$$F_{FRM} = \frac{F_{osc}}{D \times K \times \text{No. of Mux}}$$

where

- D stands for clock divide ratio. It is set by command D5h A[3:0]. The divide ratio has the range from 1 to 16.
- K is the number of display clocks per row. The value is derived by
 $K = \text{Phase 1 period} + \text{Phase 2 period} + \text{BANK0 pulse width}$
 $= 2 + 2 + 50 = 54$ at power on reset
 (Please refer to Section 8.6 “Segment Drivers / Common Drivers” for the details of the “Phase”)
- Number of multiplex ratio is set by command A8h. The power on reset value is 63 (i.e. 64MUX).
- F_{OSC} is the oscillator frequency. It can be changed by command D5h A[7:4]. The higher the register setting results in higher frequency.

8.4 FR synchronization

FR synchronization signal can be used to prevent tearing effect.

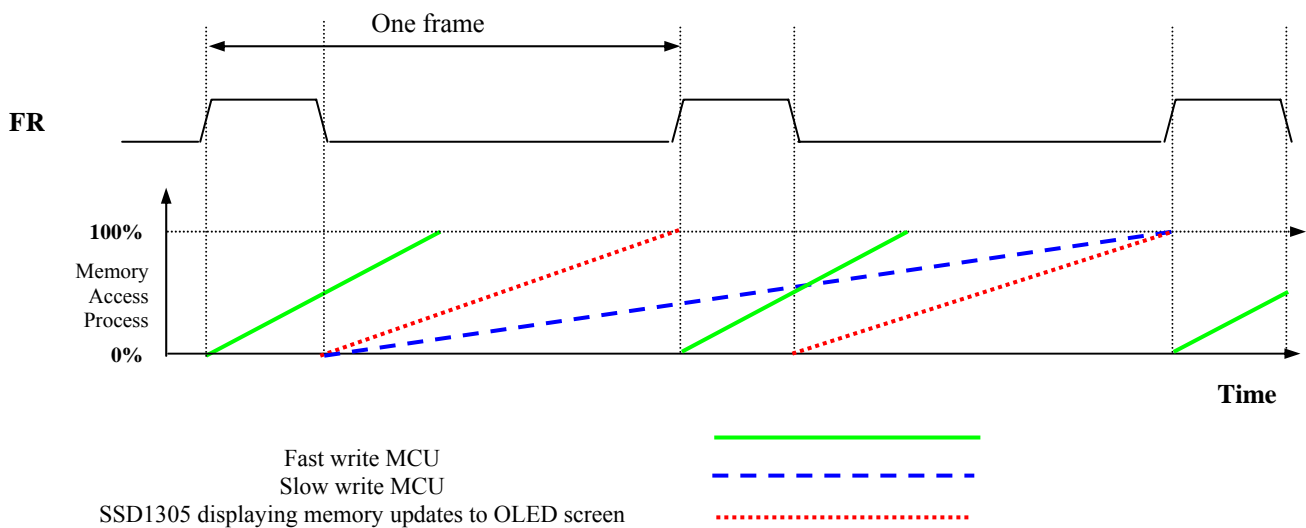

The starting time to write a new image to OLED driver is depended on the MCU writing speed. If MCU can finish writing a frame image within one frame period, it is classified as fast write MCU. For MCU needs longer writing time to complete (more than one frame but within two frames), it is a slow write one.

For fast write MCU: MCU should start to write new frame of ram data just after rising edge of FR pulse and should be finished well before the rising edge of the next FR pulse.

For slow write MCU: MCU should start to write new frame ram data after the falling edge of the 1st FR pulse and must be finished before the rising edge of the 3rd FR pulse.

8.5 Reset Circuit

When RES# input is LOW, the chip is initialized with the following status:

1. Display is OFF
2. 132 x 64 Display Mode
3. Normal segment and display data column address and row address mapping (SEG0 mapped to address 00h and COM0 mapped to address 00h)
4. Shift register data clear in serial interface
5. Display start line is set at display RAM address 0
6. Column address counter is set at 0
7. Normal scan direction of the COM outputs
8. Contrast control register is set at 80h
9. Normal display mode (Equivalent to A4h command)

8.6 Segment Drivers / Common Drivers

Segment drivers deliver 132 current sources to drive the OLED panel. The driving current can be adjusted from 0 to 320uA with 256 steps. Common drivers generate voltage-scanning pulses.

The segment driving waveform is divided into three phases:

1. In phase 1, the OLED pixel charges of previous image are discharged in order to prepare for next image content display.
2. In phase 2, the OLED pixel is driven to the targeted voltage. The pixel is driven to attain the corresponding voltage level from V_{SS} . The period of phase 2 can be programmed in length from 1 to 15 DCLKs. If the capacitance value of the pixel of OLED panel is larger, a longer period is required to charge up the capacitor to reach the desired voltage.
3. In phase 3, the OLED driver switches to use current source to drive the OLED pixels and this is the current drive stage. SSD1305 employs PWM (Pulse Width Modulation) method to control the brightness of area color A, B, C, D color individually. The longer the waveform in current drive stage is, the brighter is the pixel and vice versa.

Figure 8-11 : Segment Output Waveform in three phases

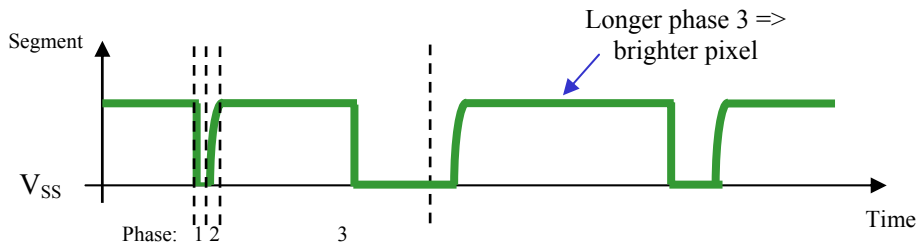

After finishing phase 3, the driver IC will go back to phase 1 to display the next row image data. This three-step cycle is run continuously to refresh image display on OLED panel.

The length of phase 3 for area colors: A,B,C and monochrome BANK0 can be configured by command 91h "Set Look Up Table". There are 64 steps available for each color but the one of color D is fixed at 64. The unit of the step is in DCLK.

For example, the look up table for area color A, B, is set to 20, 40 DCLKs respectively. Color B is set to be brighter than color A. Then the result segment output waveform of these two colors is shown below.

Figure 8-12 : Segment Output Waveform for two different colors LUT setting

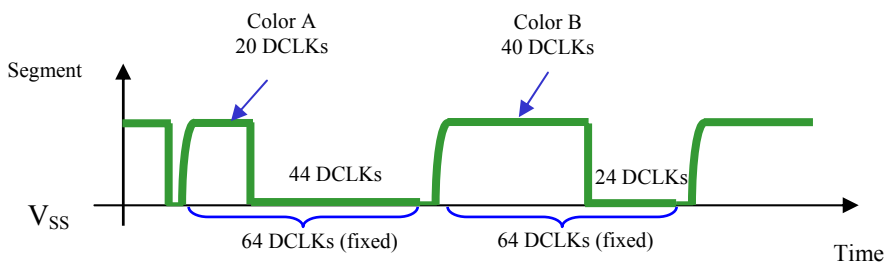

In phase 3, the segment output waveforms under the monochrome mode and area color mode are different.

In monochrome mode, if the length of current drive pulse width is set to 50, after finishing 50 DCLKs in current drive phase, the driver IC will go back to phase 1 for next row display.

Figure 8-13 : Example of Segment Output Waveform of monochrome display section under monochrome mode

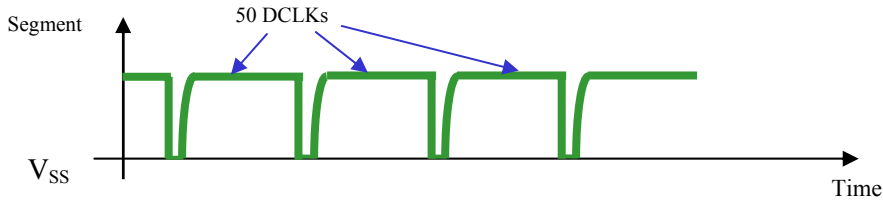

In area color mode, the phase 3 of both BANK0 and area color banks (BANK1 to BANK32) are fixed into 64 DCLKs. For instance, if the length of the pulse width is set to 50, then after the end of 50 DCLKs of current drive phase, the segment waveform will be gone to V_{SS} level and the driver is still in current drive phase. This phase will be end after 64 DCLKs from the start of the phase is passed. And then the drive goes back to phase 1 for next row display. Figure 8-14 shows the example of the segment output waveform of area color display section when the pulse width of area color is set to 50.

Figure 8-14 : Example of Segment Output Waveform of area color display section under area color mode

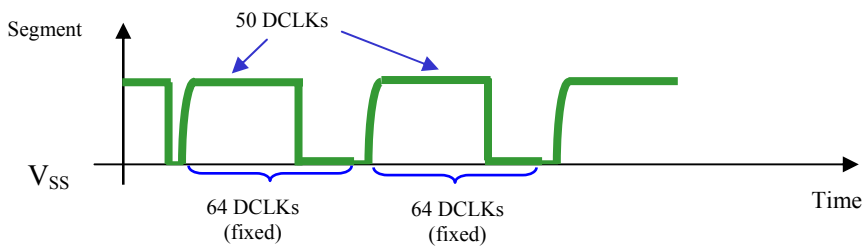

8.7 Graphic Display Data RAM (GDDRAM)

The GDDRAM is a bit mapped static RAM holding the bit pattern to be displayed. The size of the RAM is 132 x 64 bits and the RAM is divided into eight pages, from PAGE0 to PAGE7, as shown in Figure 8-15. In GDDRAM, PAGE0 and PAGE1 are belonged to area color section with resolution 132x16. PAGE2 to PAGE7 are used for monochrome 132x48 dot matrix display.

Figure 8-15 : GDDRAM pages structure of SSD1305

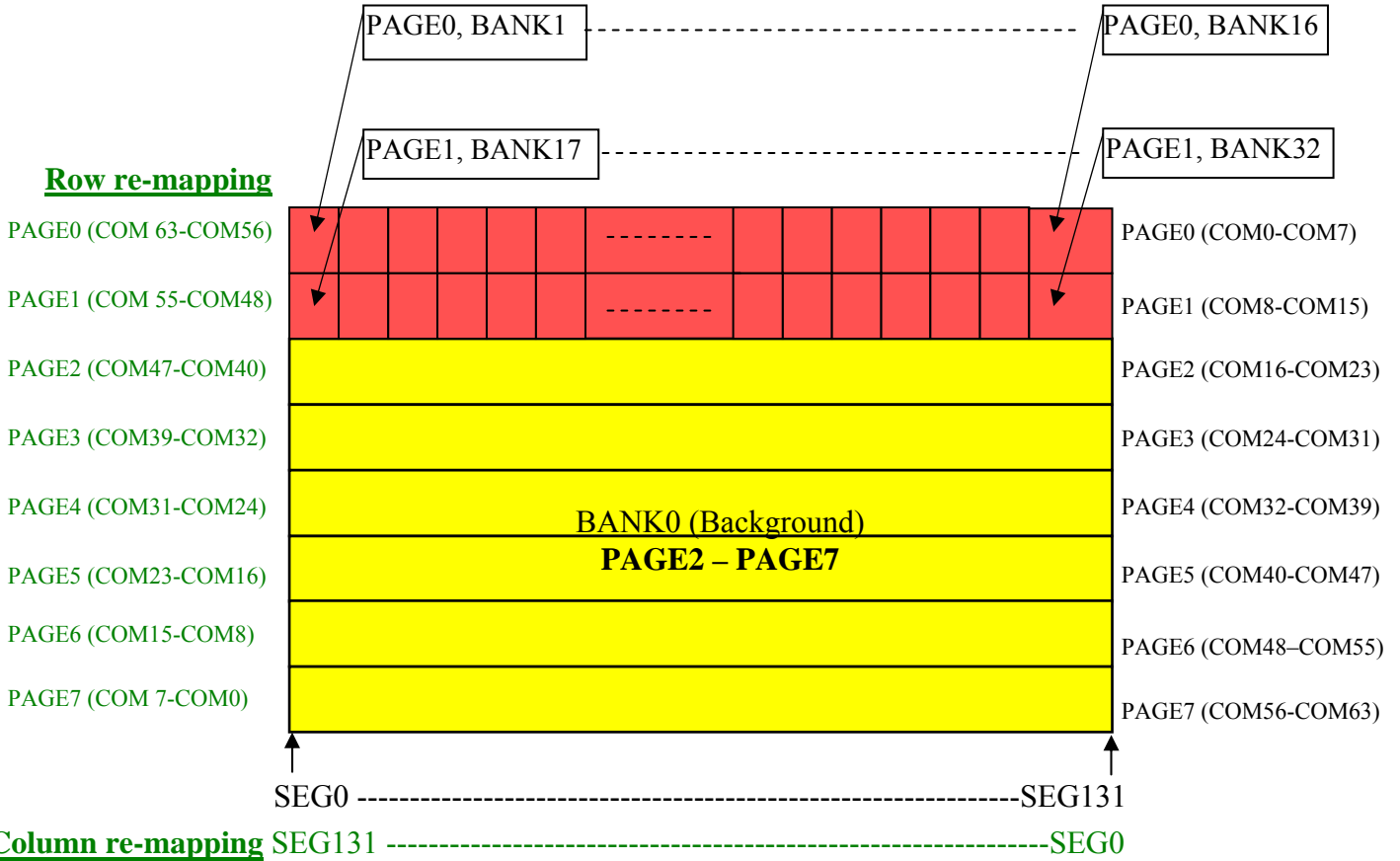

When one data byte is written into GDDRAM, all the rows image data of the same page of the current column are filled (i.e. the whole column (8 bits) pointed by the column address pointer is filled.). Data bit D0 is written into the top row, while data bit D7 is written into bottom row as shown in Figure 8-16.

Figure 8-16 : Enlargement of GDDRAM (No row re-mapping and column-remapping)

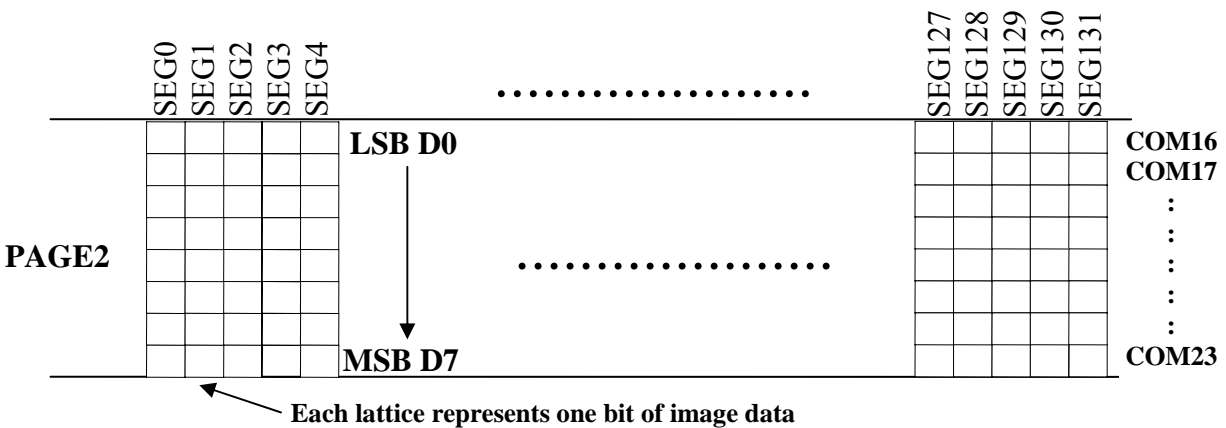

For mechanical flexibility, re-mapping on both Segment and Common outputs can be selected by software as shown in Figure 8-15.

For vertical shifting of the display, an internal register storing the display start line can be set to control the portion of the RAM data to be mapped to the display (command D3h).

8.8 Area Color Decoder

The 132x64 display matrix is divided into 8 pages. The first two pages, PAGE0 and PAGE1, are divided into 32 banks. BANK16 and BANK32 consist of a display area of 12x8 pixels. Other banks (BANK0 to BANK15 & BANK17 to BANK31) have matrices of 8x8 pixels. Each bank can be programmed to any one of the four colors (color A, B, C and D) as the example shown in Figure 8-17. Detailed operation can be referred to command 92h in Table 9-1.

Figure 8-17 : Example of area color assignment on a 132x64 OLED panel

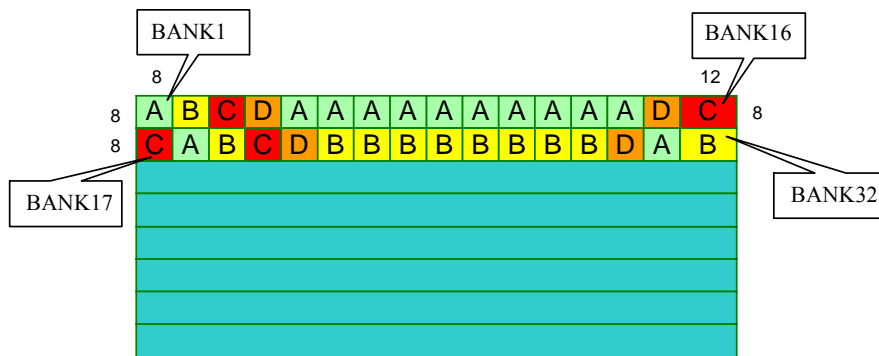

8.9 SEG/COM Driving block

This block is used to derive the incoming power sources into the different levels of internal use voltage and current.

- V_{CC} is the most positive voltage supply.
- V_{COMH} is the Common deselected level. It is internally regulated.
- V_{LSS} is the ground path of the analog and panel current.
- I_{REF} is a reference current source for segment current drivers I_{SEG} . The relationship between reference current and segment current of a color is:

$$I_{SEG} = \text{Contrast} / 256 \times I_{REF} \times \text{scale factor}$$

in which

the contrast (0~255) is set by Set Contrast command 81h; and
the scale factor is 32 by default.

The magnitude of I_{REF} is controlled by the value of resistor, which is connected between I_{REF} pin and V_{SS} as shown in Figure 8-18. It is recommended to set I_{REF} to 10uA +/- 2uA so as to achieve $I_{SEG} = 320\mu\text{A}$ at maximum contrast 255.

Figure 8-18 : I_{REF} Current Setting by Resistor Value

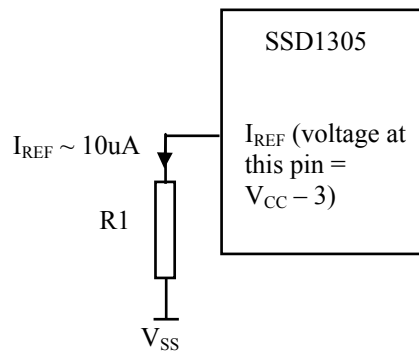

Since the voltage at I_{REF} pin is $V_{CC} - 3\text{V}$, the value of resistor $R1$ can be found as below.

$$R1 = (\text{Voltage at } I_{REF} - V_{SS}) / I_{REF} = (V_{CC} - 3) / 10\mu\text{A} \approx 910\text{k}\Omega \text{ for } V_{CC} = 12\text{V}.$$

8.10 Power ON and OFF sequence

The following figures illustrate the recommended power ON and power OFF sequence of SSD1305 (assume V_{DD} and V_{DDIO} are at the same voltage level).

Power ON sequence:

1. Power ON V_{DD} , V_{DDIO} .
2. After V_{DD} , V_{DDIO} become stable, set RES# pin LOW (logic low) for at least 3 μ s (t_1)⁽⁴⁾ and then HIGH (logic high).
3. After set RES# pin LOW (logic low), wait for at least 3 μ s (t_2). Then Power ON V_{CC} .⁽¹⁾
4. After V_{CC} become stable, send command AFh for display ON. SEG/COM will be ON after 100ms (t_{AF}).

Figure 8-19 : The Power ON sequence

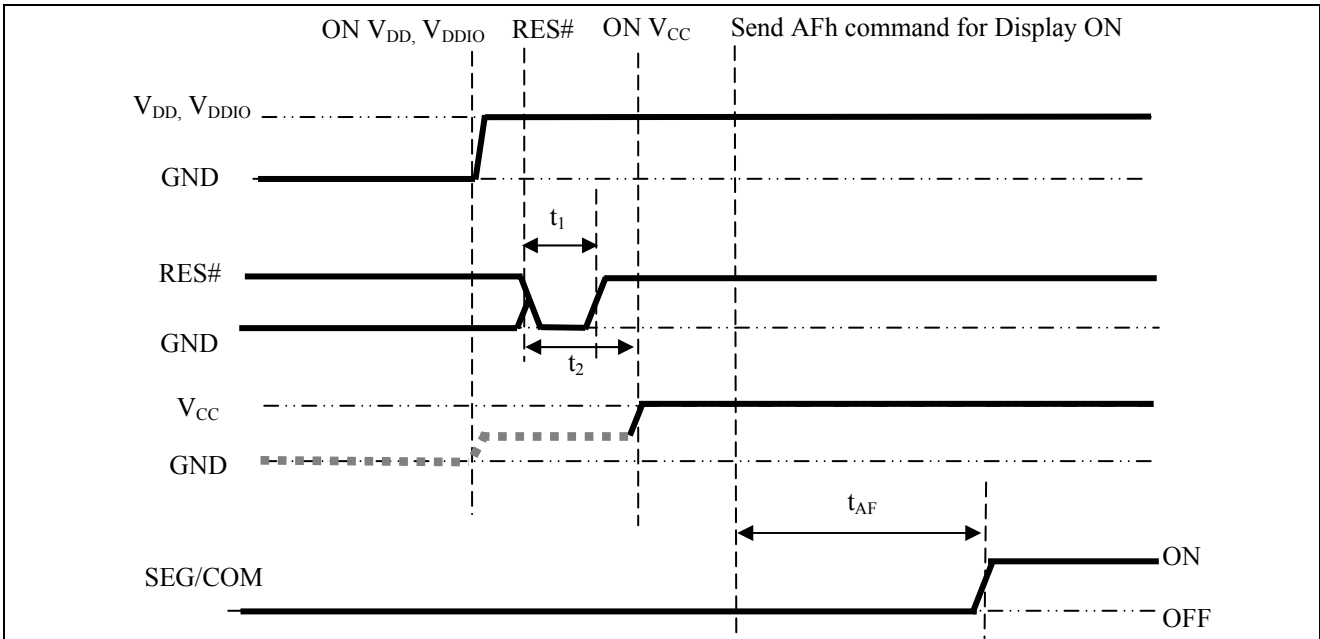

Power OFF sequence:

1. Send command AEh for display OFF.
2. Power OFF V_{CC} .^{(1), (2), (3)}
3. Wait for t_{OFF} . Power OFF V_{DD} , V_{DDIO} . (where Minimum $t_{OFF}=0$ ms⁽⁵⁾, Typical $t_{OFF}=100$ ms)

Figure 8-20 : The Power OFF sequence

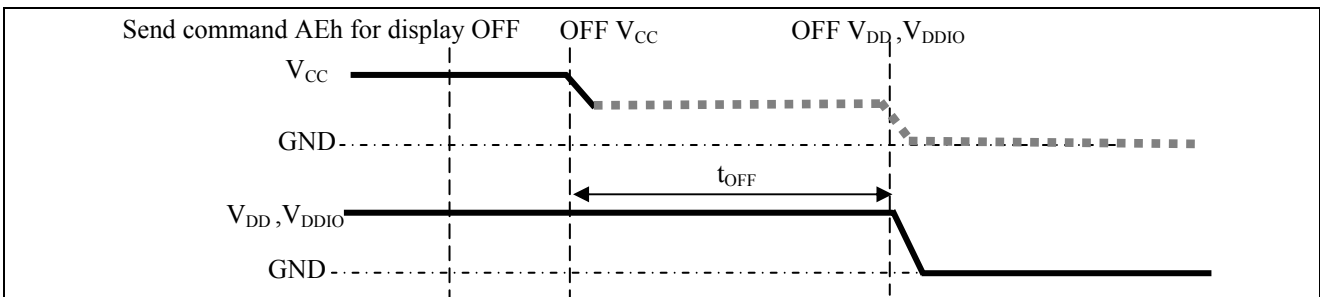

Note:

- (1) Since an ESD protection circuit is connected between V_{DD} , V_{DDIO} and V_{CC} , V_{CC} becomes lower than V_{DD} whenever V_{DD} , V_{DDIO} is ON and V_{CC} is OFF as shown in the dotted line of V_{CC} in Figure 8-19 and Figure 8-20.
- (2) V_{CC} should be kept float (disable) when it is OFF.
- (3) Power Pins (V_{DD} , V_{CC}) can never be pulled to ground under any circumstance.
- (4) The register values are reset after t_1 .
- (5) V_{DD} should not be Power OFF before V_{CC} Power OFF.

9 COMMAND TABLE

Table 9-1: Command Table

(D/C#=0, R/W#(WR#) = 0, E(RD#=1) unless specific setting is stated)

Fundamental Command Table											
D/C#	Hex	D7	D6	D5	D4	D3	D2	D1	D0	Command	Description
0	00~0F	0	0	0	0	X ₃	X ₂	X ₁	X ₀	Set Lower Column Start Address for Page Addressing Mode	Set the lower nibble of the column start address register for Page Addressing Mode using X[3:0] as data bits. The initial display line register is reset to 0000b after RESET.
0	10~1F	0	0	0	1	X ₃	X ₂	X ₁	X ₀	Set Higher Column Start Address for Page Addressing Mode	Set the higher nibble of the column start address register for Page Addressing Mode using X[3:0] as data bits. The initial display line register is reset to 0000b after RESET.
0 0	20 A[1:0]	0 *	0 *	1 *	0 *	0 *	0 *	0 A ₁	0 A ₀	Set Memory Addressing Mode	A[1:0] = 00b, Horizontal Addressing Mode A[1:0] = 01b, Vertical Addressing Mode A[1:0] = 10b, Page Addressing Mode (RESET) A[1:0] = 11b, Invalid
0 0 0	21 A[7:0] B[7:0]	0 A ₇ B ₇	0 A ₆ B ₆	1 A ₅ B ₅	0 A ₄ B ₄	0 A ₃ B ₃	0 A ₂ B ₂	0 A ₁ B ₁	1 A ₀ B ₀	Set Column Address	Setup column start and end address A[7:0] : Column start address, range : 0-131d, (RESET=0d) B[7:0]: Column end address, range : 0-131d, (RESET =131d)
0 0 0	22 A[2:0] B[2:0]	0 * *	0 * *	1 * *	0 * *	0 * *	0 A ₂ B ₂	1 A ₁ B ₁	0 A ₀ B ₀	Set Page Address	Setup page start and end address A[2:0] : Page start Address, range : 0-7d, (RESET = 0d) B[2:0] : Page end Address, range : 0-7d, (RESET = 7d)
0	40~7F	0	1	X ₅	X ₄	X ₃	X ₂	X ₁	X ₀	Set Display Start Line	Set display RAM display start line register from 0-63 using X ₅ X ₃ X ₂ X ₁ X ₀ . Display start line register is reset to 000000b during RESET.
0 0	81 A[7:0]	1 A ₇	0 A ₆	0 A ₅	0 A ₄	0 A ₃	0 A ₂	0 A ₁	1 A ₀	Set Contrast Control For BANK0	Double byte command to select 1 out of 256 contrast steps. Contrast increases as the value increases. (RESET = 80h)
0 0	82 A[7:0]	1 A ₇	0 A ₆	0 A ₅	0 A ₄	0 A ₃	0 A ₂	1 A ₁	0 A ₀	Set Brightness For Area Color Banks	Double byte command to select 1 out of 256 brightness steps. Brightness increases as the value increases. (RESET = 80h)
0 0 0 0	91 X[5:0] A[5:0] B[5:0] C[5:0]	1 * * * *	0 * * * *	0 X ₅ A ₅ B ₅ C ₅	1 X ₄ A ₄ B ₄ C ₄	0 X ₃ A ₃ B ₃ C ₃	0 X ₂ A ₂ B ₂ C ₂	0 X ₁ A ₁ B ₁ C ₁	1 X ₀ A ₀ B ₀ C ₀	Set Look Up Table (LUT)	Set current drive pulse width of BANK0, Color A, B and C. BANK0: X[5:0] = 31... 63; for pulse width set to 32 ~ 64 clocks (RESET = 110001b) Color A: A[5:0] same as above (RESET = 111111b) Color B: B[5:0] same as above (RESET = 111111b) Color C: C[5:0] same as above (RESET = 111111b) Note (¹) Color D pulse width is fixed at 64 clocks pulse.

Fundamental Command Table											
D/C#	Hex	D7	D6	D5	D4	D3	D2	D1	D0	Command	Description
0000	92 A[7:0] B[7:0] C[7:0] D[7:0]	1 A ₇ B ₇ C ₇ D ₇	0 A ₆ B ₆ C ₆ D ₆	0 A ₅ B ₅ C ₅ D ₅	1 A ₄ B ₄ C ₄ D ₄	0 A ₃ B ₃ C ₃ D ₃	0 A ₂ B ₂ C ₂ D ₂	1 A ₁ B ₁ C ₁ D ₁	0 A ₀ B ₀ C ₀ D ₀	Set Bank Color of BANK1 to BANK16 (PAGE0)	Set the bank color of BANK1~BANK16 to any one of the 4 colors : A, B, C and D . A[1:0] : 00b, 01b, 10b, or 11b for Color = A, B, C or D of BANK1 A[3:2] : 00b, 01b, 10b, or 11b for Color = A, B, C or D of BANK2 : : D[5:4] : 00b, 01b, 10b, or 11b for Color = A, B, C or D of BANK15 D[7:6] : 00b, 01b, 10b, or 11b for Color = A, B, C or D of BANK16
0000	93 A[7:0] B[7:0] C[7:0] D[7:0]	1 A ₇ B ₇ C ₇ D ₇	0 A ₆ B ₆ C ₆ D ₆	0 A ₅ B ₅ C ₅ D ₅	1 A ₄ B ₄ C ₄ D ₄	0 A ₃ B ₃ C ₃ D ₃	0 A ₂ B ₂ C ₂ D ₂	1 A ₁ B ₁ C ₁ D ₁	1 A ₀ B ₀ C ₀ D ₀	Set Bank Color of BANK17~BANK32 (PAGE1)	Set the bank color of BANK17~BANK32 to any one of the 4 colors: A, B, C and D. A[1:0] : 00b, 01b, 10b, or 11b for Color = A, B, C or D of BANK17 A[3:2] : 00b, 01b, 10b, or 1b1 for Color = A, B, C or D of BANK18 : : D[5:4] : 00b, 01b, 10b, or 11b for Color = A, B, C or D of BANK31 D[7:6] : 00b, 01b, 10b, or 11b for Color = A, B, C or D of BANK32
0	A0/A1	1	0	1	0	0	0	0	X ₀	Set Segment Re-map	X[0]=0b: column address 0 is mapped to SEG0 (RESET) X[0]=1b: column address 131 is mapped to SEG0
0	A4/A5	1	0	1	0	0	1	0	X ₀	Entire Display ON	X ₀ =0b: Resume to RAM content display (RESET) Output follows RAM content X ₀ =1b: Entire display ON Output ignores RAM content
0	A6/A7	1	0	1	0	0	1	1	X ₀	Set Normal/Inverse Display	X[0]=0b: Normal display (RESET) 0 in RAM: OFF in display panel 1 in RAM: ON in display panel X[0]=1b: inverse display 0 in RAM: ON in display panel 1 in RAM: OFF in display panel
00	A8 A[5:0]	1 *	0 *	1 A ₅	0 A ₄	1 A ₃	0 A ₂	0 A ₁	0 A ₀	Set Multiplex Ratio	Set MUX ratio to N+1 MUX N=A[5:0] : from 16MUX to 64MUX, RESET= 111111b (i.e. 64MUX) A[5:0] from 0 to 14 are invalid entry.
0	AA	1	0	1	0	1	0	1	0	Reserved	Reserved
0000	AB A[3:0] B[7:0] C[7:0]	1 * B ₇ C ₇	0 * B ₆ C ₆	1 * B ₅ C ₅	0 * B ₄ C ₄	1 A ₃ B ₃ C ₃	0 A ₂ B ₂ C ₂	1 A ₁ B ₁ C ₁	1 A ₀ B ₀ C ₀	Dim mode setting	A[3:0] : Reserved (set as 0000b) B [7:0] : Set contrast for BANK0, valid range 0-255d, please refer to command 81h C [7:0] : Set brightness for color bank, valid range 0-255d, please refer to command 82h

Fundamental Command Table											
D/C#	Hex	D7	D6	D5	D4	D3	D2	D1	D0	Command	Description
0 0	AD A[7:0]	1 1	0 0	1 0	0 0	1 1	1 1	0 1	1 A ₀	Master Configuration	A[0]=0b, Select external V _{CC} supply (RESET) A[0]=1b, Reserved
0	AC AE AF	1	0	1	0	1	1	A ₁	A ₀	Set Display ON/OFF	ACh = Display ON in dim mode AEh = Display OFF (sleep mode) (RESET) AFh = Display ON in normal mode
0	B0~B7	1	0	1	1	0	X ₂	X ₁	X ₀	Set Page Start Address for Page Addressing Mode	Set GDDRAM Page Start Address (PAGE0~PAGE7) for Page Addressing Mode using X[2:0].
0	C0/C8	1	1	0	0	X ₃	0	0	0	Set COM Output Scan Direction	X[3]=0b: normal mode (RESET) Scan from COM0 to COM[N-1] X[3]=1b: remapped mode. Scan from COM[N-1] to COM0 Where N is the Multiplex ratio.
0 0	D3 A[5:0]	1 *	1 *	0 A ₅	1 A ₄	0 A ₃	0 A ₂	1 A ₁	1 A ₀	Set Display Offset	Set vertical shift by COM from 0~63. The value is reset to 00h after RESET.
0	D5 A[7:0]	1 A ₇	1 A ₆	0 A ₅	1 A ₄	0 A ₃	1 A ₂	0 A ₁	1 A ₀	Set Display Clock Divide Ratio/Oscillator Frequency	A[3:0] : Define the divide ratio (D) of the display clocks (DCLK): Divide ratio= A[3:0] + 1, RESET is 0000b (divide ratio = 1) A[7:4] : Set the Oscillator Frequency, F _{OSC} . Oscillator Frequency increases with the value of A[7:4] and vice versa. RESET is 0111b Range:0000b~1111b Frequency increases as setting value increases. Refer to section 10.1.23 for details.
0 0	D8	1 0	1 0	0 X ₅	1 X ₄	1 0	0 X ₂	0 0	0 X ₀	Set Area Color Mode ON/OFF & Low Power Display Mode	X[5:4]= 00b (RESET) : monochrome mode X[5:4]= 11b Area Color enable X[2]=0b and X[0]=0b: Normal power mode(RESET) X[2]=1b and X[0]=1b: Set low power display mode
0 0	D9 A[7:0]	1 A ₇	1 A ₆	0 A ₅	1 A ₄	1 A ₃	0 A ₂	0 A ₁	1 A ₀	Set Pre-charge Period	A[3:0] : Phase 1 period of up to 15 DCLK clocks (RESET=2h); 0 is invalid entry A[7:4] : Phase 2 period of up to 15 DCLK clocks (RESET=2h); 0 is invalid entry
0 0	DA	1 0	1 0	0 X ₅	1 X ₄	1 0	0 0	1 1	0 0	Set COM Pins Hardware Configuration	X[4]=0b, Sequential COM pin configuration X[4]=1b(RESET), Alternative COM pin configuration X[5]=0b(RESET), Disable COM Left/Right remap X[5]=1b, Enable COM Left/Right remap Please refer to Table 10-3 for details.

Fundamental Command Table																							
D/C#	Hex	D7	D6	D5	D4	D3	D2	D1	D0	Command	Description												
0	DB	1	1	0	1	1	0	1	1	Set V_{COMH} Deselect Level	<table border="1"> <thead> <tr> <th>A[5:2]</th> <th>Hex code</th> <th>V_{COMH} deselect level</th> </tr> </thead> <tbody> <tr> <td>0000b</td> <td>00h</td> <td>$\sim 0.43 \times V_{CC}$</td> </tr> <tr> <td>1101b</td> <td>34h</td> <td>$\sim 0.77 \times V_{CC}$ (RESET)</td> </tr> <tr> <td>1111b</td> <td>3Ch</td> <td>$\sim 0.83 \times V_{CC}$</td> </tr> </tbody> </table>	A[5:2]	Hex code	V_{COMH} deselect level	0000b	00h	$\sim 0.43 \times V_{CC}$	1101b	34h	$\sim 0.77 \times V_{CC}$ (RESET)	1111b	3Ch	$\sim 0.83 \times V_{CC}$
A[5:2]	Hex code	V_{COMH} deselect level																					
0000b	00h	$\sim 0.43 \times V_{CC}$																					
1101b	34h	$\sim 0.77 \times V_{CC}$ (RESET)																					
1111b	3Ch	$\sim 0.83 \times V_{CC}$																					
0	A[5:2]	0	0	A ₅	A ₄	A ₃	A ₂	0	0														
0	E0	1	1	1	0	0	0	0	0	Enter Read Modify Write	Enter the Read Modify Write mode. Details please refer to section 10.1.28.												
0	E3	1	1	1	0	0	0	1	1	NOP	Command for no operation												
0	EE	1	1	1	0	1	1	1	0	Exit Read Modify Write	Exit the Read Modify Write mode (Please refer to command E0h)												

Graphic Acceleration Command Table

D/C#	Hex	D7	D6	D5	D4	D3	D2	D1	D0	Command	Description																										
0	26/27	0	0	1	0	0	1	1	X ₀	Horizontal Scroll Setup	X[0]=0, Right Horizontal Scroll X[0]=1, Left Horizontal Scroll A[2:0] : Set number of column scroll offset 000b No horizontal scroll 001b Horizontal scroll by 1 column 010b Horizontal scroll by 2 columns 011b Horizontal scroll by 3 columns 100b Horizontal scroll by 4 columns Other values are invalid. B[2:0] : Define start page address <table border="1"> <tr> <td>000b – PAGE0</td> <td>011b – PAGE3</td> <td>110b – PAGE6</td> </tr> <tr> <td>001b – PAGE1</td> <td>100b – PAGE4</td> <td>111b – PAGE7</td> </tr> <tr> <td>010b – PAGE2</td> <td>101b – PAGE5</td> <td></td> </tr> </table> C[2:0] : Set time interval between each scroll step in terms of frame frequency <table border="1"> <tr> <td>000b – 6 frames</td> <td>100b – 3 frames</td> </tr> <tr> <td>001b – 32 frames</td> <td>101b – 4 frames</td> </tr> <tr> <td>010b – 64 frames</td> <td>110b – 2 frame</td> </tr> <tr> <td>011b – 128 frames</td> <td>111b – Invalid</td> </tr> </table> D[2:0] : Define end page address <table border="1"> <tr> <td>000b – PAGE0</td> <td>011b – PAGE3</td> <td>110b – PAGE6</td> </tr> <tr> <td>001b – PAGE1</td> <td>100b – PAGE4</td> <td>111b – PAGE7</td> </tr> <tr> <td>010b – PAGE2</td> <td>101b – PAGE5</td> <td></td> </tr> </table> The value of D[2:0] must be larger or equal to B[2:0]	000b – PAGE0	011b – PAGE3	110b – PAGE6	001b – PAGE1	100b – PAGE4	111b – PAGE7	010b – PAGE2	101b – PAGE5		000b – 6 frames	100b – 3 frames	001b – 32 frames	101b – 4 frames	010b – 64 frames	110b – 2 frame	011b – 128 frames	111b – Invalid	000b – PAGE0	011b – PAGE3	110b – PAGE6	001b – PAGE1	100b – PAGE4	111b – PAGE7	010b – PAGE2	101b – PAGE5	
000b – PAGE0	011b – PAGE3	110b – PAGE6																																			
001b – PAGE1	100b – PAGE4	111b – PAGE7																																			
010b – PAGE2	101b – PAGE5																																				
000b – 6 frames	100b – 3 frames																																				
001b – 32 frames	101b – 4 frames																																				
010b – 64 frames	110b – 2 frame																																				
011b – 128 frames	111b – Invalid																																				
000b – PAGE0	011b – PAGE3	110b – PAGE6																																			
001b – PAGE1	100b – PAGE4	111b – PAGE7																																			
010b – PAGE2	101b – PAGE5																																				
0	A[2:0]	*	*	*	*	*	A ₂	A ₁	A ₀																												
0	B[2:0]	*	*	*	*	*	B ₂	B ₁	B ₀																												
0	C[2:0]	*	*	*	*	*	C ₂	C ₁	C ₀																												
0	D[2:0]	*	*	*	*	*	D ₂	D ₁	D ₀																												
0	29/2A	0	0	1	0	1	0	X ₁	X ₀	Continuous Vertical and Horizontal Scroll Setup	X ₁ X ₀ =01b : Vertical and Right Horizontal Scroll X ₁ X ₀ =10b : Vertical and Left Horizontal Scroll A[2:0] : Set number of column scroll offset 000b No horizontal scroll 001b Horizontal scroll by 1 column 010b Horizontal scroll by 2 columns 011b Horizontal scroll by 3 columns 100b Horizontal scroll by 4 columns Other values are invalid. B[2:0] : Define start page address <table border="1"> <tr> <td>000b – PAGE0</td> <td>011b – PAGE3</td> <td>110b – PAGE6</td> </tr> <tr> <td>001b – PAGE1</td> <td>100b – PAGE4</td> <td>111b – PAGE7</td> </tr> <tr> <td>010b – PAGE2</td> <td>101b – PAGE5</td> <td></td> </tr> </table> C[2:0] : Set time interval between each scroll step in terms of frame frequency <table border="1"> <tr> <td>000b – 6 frames</td> <td>100b – 3 frames</td> </tr> <tr> <td>001b – 32 frames</td> <td>101b – 4 frames</td> </tr> <tr> <td>010b – 64 frames</td> <td>110b – 2 frame</td> </tr> <tr> <td>011b – 128 frames</td> <td>111b – Invalid</td> </tr> </table> D[2:0] : Define end page address <table border="1"> <tr> <td>000b – PAGE0</td> <td>011b – PAGE3</td> <td>110b – PAGE6</td> </tr> <tr> <td>001b – PAGE1</td> <td>100b – PAGE4</td> <td>111b – PAGE7</td> </tr> <tr> <td>010b – PAGE2</td> <td>101b – PAGE5</td> <td></td> </tr> </table> The value of D[2:0] must be larger or equal to B[2:0] E[5:0] : Vertical scrolling offset e.g. E[5:0]= 01h refer to offset =1 row E[5:0] =3Fh refer to offset =63 rows	000b – PAGE0	011b – PAGE3	110b – PAGE6	001b – PAGE1	100b – PAGE4	111b – PAGE7	010b – PAGE2	101b – PAGE5		000b – 6 frames	100b – 3 frames	001b – 32 frames	101b – 4 frames	010b – 64 frames	110b – 2 frame	011b – 128 frames	111b – Invalid	000b – PAGE0	011b – PAGE3	110b – PAGE6	001b – PAGE1	100b – PAGE4	111b – PAGE7	010b – PAGE2	101b – PAGE5	
000b – PAGE0	011b – PAGE3	110b – PAGE6																																			
001b – PAGE1	100b – PAGE4	111b – PAGE7																																			
010b – PAGE2	101b – PAGE5																																				
000b – 6 frames	100b – 3 frames																																				
001b – 32 frames	101b – 4 frames																																				
010b – 64 frames	110b – 2 frame																																				
011b – 128 frames	111b – Invalid																																				
000b – PAGE0	011b – PAGE3	110b – PAGE6																																			
001b – PAGE1	100b – PAGE4	111b – PAGE7																																			
010b – PAGE2	101b – PAGE5																																				
0	A[2:0]	*	*	*	*	*	A ₂	A ₁	A ₀																												
0	B[2:0]	*	*	*	*	*	B ₂	B ₁	B ₀																												
0	C[2:0]	*	*	*	*	*	C ₂	C ₁	C ₀																												
0	D[2:0]	*	*	*	*	*	D ₂	D ₁	D ₀																												
0	E[5:0]	*	*	E ₅	E ₄	E ₃	E ₂	E ₁	E ₀																												

Graphic Acceleration Command Table

D/C#	Hex	D7	D6	D5	D4	D3	D2	D1	D0	Command	Description
0	2E	0	0	1	0	1	1	1	0	Deactivate scroll	<p>Stop scrolling that is configured by command 26h/27h/29h/2Ah.</p> <p>Note ⁽¹⁾ After sending 2Eh command to deactivate the scrolling action, the ram data needs to be rewritten.</p>
0	2F	0	0	1	0	1	1	1	1	Activate scroll	<p>Start scrolling that is configured by the scrolling setup commands :26h/27h/29h/2Ah with the following valid sequences: Valid command sequence 1: 26h ;2Fh. Valid command sequence 2: 27h ;2Fh. Valid command sequence 3: 29h ;2Fh. Valid command sequence 4: 2Ah ;2Fh.</p> <p>For example, if “26h; 2Ah; 2Fh.” commands are issued, the setting in the last scrolling setup command, i.e. 2Ah in this case, will be executed. In other words, setting in the last scrolling setup command overwrites the setting in the previous scrolling setup commands.</p>
0 0 0	A3 A[5:0] B[6:0]	1 * *	0 * B ₆	1 A ₅ B ₅	0 A ₄ B ₄	0 A ₃ B ₃	0 A ₂ B ₂	1 A ₁ B ₁	1 A ₀ B ₀	Set Vertical Scroll Area	<p>A[5:0] : Set No. of rows in top fixed area. The No. of rows in top fixed area is referenced to the top of the GDDRAM (i.e. row 0).[RESET = 0]</p> <p>B[6:0] : Set No. of rows in scroll area. This is the number of rows to be used for vertical scrolling. The scroll area starts in the first row below the top fixed area. [RESET = 64]</p> <p>Note ⁽¹⁾ A[5:0]+B[6:0] <= MUX ratio ⁽²⁾ B[6:0] <= MUX ratio ^(3a) Vertical scrolling offset (E[5:0] in 29h/2Ah) < B[6:0] ^(3b) Set Display Start Line (X5X4X3X2X1X0 of 40h~7Fh) < B[6:0] ⁽⁴⁾ The last row of the scroll area shifts to the first row of the scroll area. ⁽⁵⁾ For 64d MUX display A[5:0] = 0, B[6:0]=64 : whole area scrolls A[5:0]= 0, B[6:0] < 64 : top area scrolls A[5:0] + B[6:0] < 64 : central area scrolls A[5:0] + B[6:0] = 64 : bottom area scrolls Please refer to Figure 10-14 for details.</p>

Note

⁽¹⁾ “*” stands for “Don’t care”.

Table 9-2 : Read Command Table

Bit Pattern	Command	Description
D ₇ D ₆ D ₅ D ₄ D ₃ D ₂ D ₁ D ₀	Status Register Read	D[7] : Reserve D[6] : “1” for display OFF / “0” for display ON D[5] : Reserve D[4] : Reserve D[3] : Reserve D[2] : Reserve D[1] : Reserve D[0] : Reserve

Note

⁽¹⁾ Patterns other than those given in the Command Table are prohibited to enter the chip as a command; as unexpected results can occur.

9.1 Data Read / Write

To read data from the GDDRAM, select HIGH for both the R/W# (WR#) pin and the D/C# pin for 6800-series parallel mode and select LOW for the E (RD#) pin and HIGH for the D/C# pin for 8080-series parallel mode. No data read is provided in serial mode operation.

In normal data read mode the GDDRAM column address pointer will be increased automatically by one after each data read.

Also, a dummy read is required before the first data read.

To write data to the GDDRAM, select LOW for the R/W# (WR#) pin and HIGH for the D/C# pin for both 6800-series parallel mode and 8080-series parallel mode. The serial interface mode is always in write mode. The GDDRAM column address pointer will be increased automatically by one after each data write.

Table 9-3 : Address increment table (Automatic)

D/C#	R/W# (WR#)	Comment	Address Increment
0	0	Write Command	No
0	1	Read Status	No
1	0	Write Data	Yes
1	1	Read Data	Yes ⁽¹⁾

Note

⁽¹⁾ If read-data command is issued in read-modify-write mode no address increase occurs.

10 COMMAND DESCRIPTIONS

10.1 Fundamental Command

10.1.1 Set Lower Column Start Address for Page Addressing Mode (00h~0Fh)

This command specifies the lower nibble of the 8-bit column start address for the display data RAM under Page Addressing Mode. The column address will be incremented by each data access. Please refer to Section Table 9-1 and Section 10.1.3 for details.

10.1.2 Set Higher Column Start Address for Page Addressing Mode (10h~1Fh)

This command specifies the higher nibble of the 8-bit column start address for the display data RAM under Page Addressing Mode. The column address will be incremented by each data access. Please refer to Section Table 9-1 and Section 10.1.3 for details.

10.1.3 Set Memory Addressing Mode (20h)

There are 3 different memory addressing mode in SSD1305: page addressing mode, horizontal addressing mode and vertical addressing mode. This command sets the way of memory addressing into one of the above three modes. In there, “COL” means the graphic display data RAM column.

Page addressing mode (A[1:0]=10xb)

In page addressing mode, after the display RAM is read/written, the column address pointer is increased automatically by 1. If the column address pointer reaches column end address, the column address pointer is reset to column start address and page address pointer is not changed. Users have to set the new page and column addresses in order to access the next page RAM content. The sequence of movement of the PAGE and column address pointer for page addressing mode is shown in Figure 10-1.

Figure 10-1 : Address Pointer Movement of Page addressing mode

	COL0	COL 1	COL 130	COL 131
PAGE0	→				
PAGE1	→				
:	:	:	:	:	:
PAGE6	→				
PAGE7	→				

In normal display data RAM read or write and page addressing mode, the following steps are required to define the starting RAM access pointer location:

- Set the page start address of the target display location by command B0h to B7h.
- Set the lower start column address of pointer by command 00h~0Fh.
- Set the upper start column address of pointer by command 10h~1Fh.

For example, if the page address is set to B2h, lower column address is 03h and upper column address is 10h, then that means the starting column is SEG3 of PAGE2. The RAM access pointer is located as shown in Figure 10-2. The input data byte will be written into RAM position of column 3.

Figure 10-2 : Example of GDDRAM access pointer setting in Page Addressing Mode (No row and column-remapping)

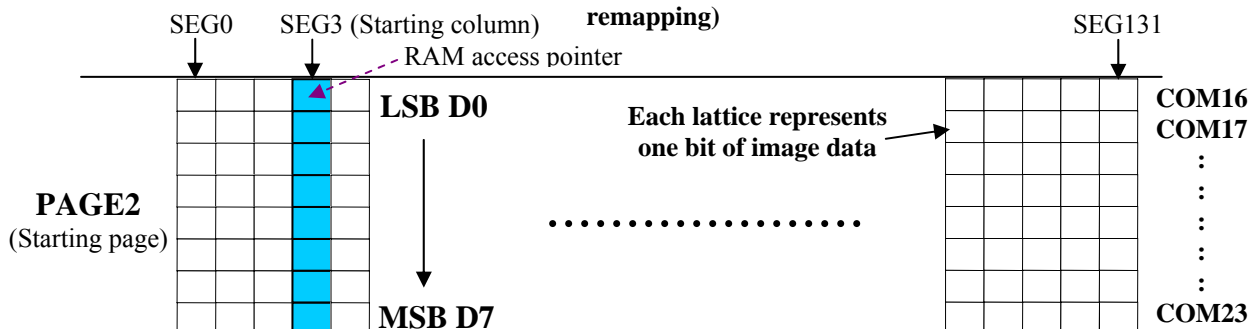

Horizontal addressing mode (A[1:0]=00b)

In horizontal addressing mode, after the display RAM is read/written, the column address pointer is increased automatically by 1. If the column address pointer reaches column end address, the column address pointer is reset to column start address and page address pointer is increased by 1. The sequence of movement of the page and column address point for horizontal addressing mode is shown in Figure 10-3. When both column and page address pointers reach the end address, the pointers are reset to column start address and page start address (Dotted line in Figure 10-3.)

Figure 10-3 : Address Pointer Movement of Horizontal addressing mode

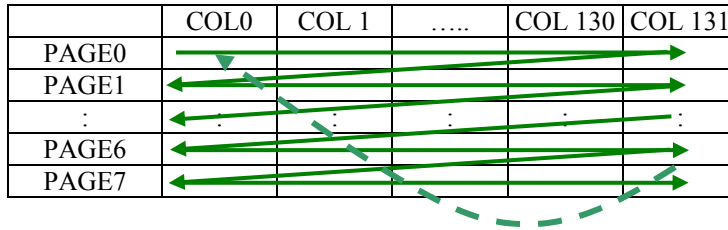

Vertical addressing mode: (A[1:0]=01b)

In vertical addressing mode, after the display RAM is read/written, the page address pointer is increased automatically by 1. If the page address pointer reaches the page end address, the page address pointer is reset to page start address and column address pointer is increased by 1. The sequence of movement of the page and column address point for vertical addressing mode is shown in Figure 10-4. When both column and page address pointers reach the end address, the pointers are reset to column start address and page start address (Dotted line in Figure 10-4.)

Figure 10-4 : Address Pointer Movement of Vertical addressing mode

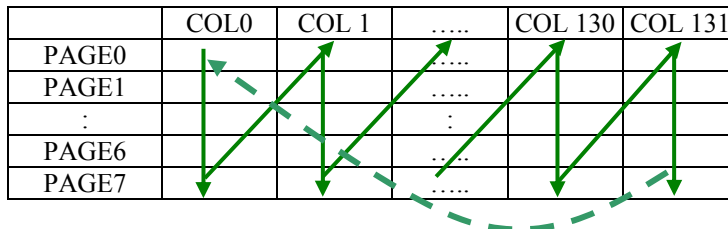

In normal display data RAM read or write and horizontal / vertical addressing mode, the following steps are required to define the RAM access pointer location:

- Set the column start and end address of the target display location by command 21h.
- Set the page start and end address of the target display location by command 22h.

Example is shown in Figure 10-5.

10.1.4 Set Column Address (21h)

This triple byte command specifies column start address and end address of the display data RAM. This command also sets the column address pointer to column start address. This pointer is used to define the current read/write column address in graphic display data RAM. If horizontal address increment mode is enabled by command 20h, after finishing read/write one column data, it is incremented automatically to the next column address. Whenever the column address pointer finishes accessing the end column address, it is reset back to start column address and the row address is incremented to the next row.

10.1.5 Set Page Address (22h)

This triple byte command specifies page start address and end address of the display data RAM. This command also sets the page address pointer to page start address. This pointer is used to define the current read/write page address in graphic display data RAM. If vertical address increment mode is enabled by command 20h, after finishing read/write one page data, it is incremented automatically to the next page address. Whenever the page address pointer finishes accessing the end page address, it is reset back to start page address.

The figure below shows the way of column and page address pointer movement through the example: column start address is set to 2 and column end address is set to 129, page start address is set to 1 and page end address is set to 6; Horizontal address increment mode is enabled by command 20h. In this case, the graphic display data RAM column accessible range is from column 2 to column 129 and from page 1 to page 6 only. In addition, the column address pointer is set to 2 and page address pointer is set to 1. After finishing read/write one pixel of data, the column address is increased automatically by 1 to access the next RAM location for next read/write operation (*solid line in Figure 10-5*). Whenever the column address pointer finishes accessing the end column 129, it is reset back to column 2 and page address is automatically increased by 1 (*solid line in Figure 10-5*). While the end page 6 and end column 129 RAM location is accessed, the page address is reset back to 1 and the column address is reset back to 2 (*dotted line in Figure 10-5*). .

Figure 10-5 : Example of Column and Row Address Pointer Movement

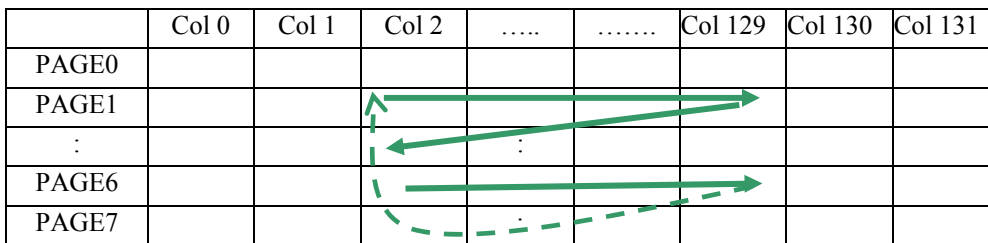

10.1.6 Set Display Start Line (40h~7Fh)

This command sets the Display Start Line register to determine starting address of display RAM, by selecting a value from 0 to 63. With value equal to 0, RAM row 0 is mapped to COM0. With value equal to 1, RAM row 1 is mapped to COM0 and so on.

Refer to Table 10-1 for more illustrations.

10.1.7 Set Contrast Control for BANK0 (81h)

This command sets the Contrast Setting of the display. The chip has 256 contrast steps from 00h to FFh. The segment output current increases as the contrast step value increases. See Figure 10-6 below.

Figure 10-6 : Segment current vs Contrast setting

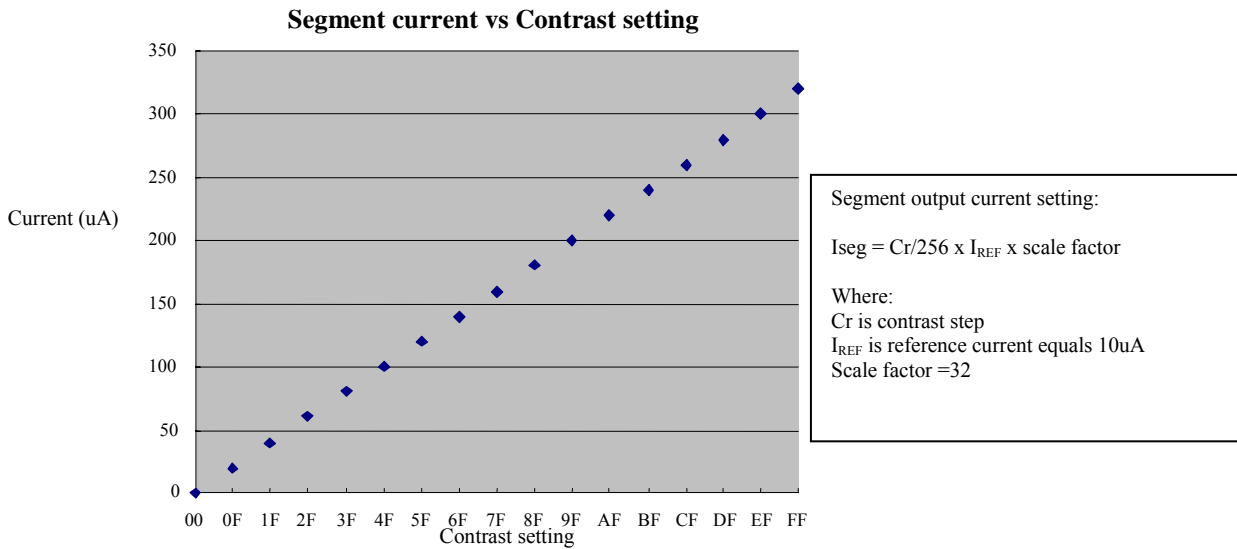

10.1.8 Set Brightness for Area Color Banks (82h)

This command sets the Brightness Setting of the display for the area color banks. The chip has 256 brightness steps from 00h to FFh. The segment output current increases as the brightness step value increases.

This setting does not affect the contrast of BANK0, which is set by command 81h.

10.1.9 Set Look Up Table (LUT) (91h)

The SSD1305 provides 4 color settings - Colors A, B, C and D for the bank color of BANK1 to BANK32 under the area color mode. The color intensity (or grey scale) is defined by the current drive pulse width. This pulse width setting must be stored in the Look Up Table (LUT). The pulse width of colors A, B, C is programmable from 32 to 64 DCLKs. The color D is fixed at 64 DCLKs pulse width. For the grey scale in BANK0, the pulse width is programmable from 32 to 64 DCLKs. Please refer to 91h command in Table 9-1 for details of the LUT setting.

After setting the pulse widths for the color of A, B, C, D and BANK0, the next step is to define the color of each display area. Each bank can be programmable to any one of the 4 colors (A, B, C and D). The user can use 92h and 93h commands for the bank color setting. It should be notice that this is only applicable in area color mode.

10.1.10 Set Bank Color of BANK1 to BANK16 (PAGE0) (92h)

This command maps the bank color (pulse width) of BANK1~BANK16 to any one of the 4 colors: A, B, C and D. For details of the setting, please refer to 92h command in Table 9-1.

10.1.11 Set Bank Color of BANK17 to BANK32 (PAGE0) (93h)

This command maps the bank color (pulse width) of BANK17~BANK32 to any one of the 4 colors: A, B, C and D. For details of the setting, please refer to 93h command in Table 9-1.

10.1.12 Set Segment Re-map (A0h/A1h)

This command changes the mapping between the display data column address and the segment driver. It allows flexibility in OLED module design. Please refer to Table 9-1.

This command only affects subsequent data input. Data already stored in GDDRAM will have no changes.

10.1.13 Entire Display ON (A4h/A5h)

A4h command enable display outputs according to the GDDRAM contents.

If A5h command is issued, then by using A4h command, the display will resume to the GDDRAM contents. In other words, A4h command resumes the display from entire display “ON” stage.

A5h command forces the entire display to be “ON”, regardless of the contents of the display data RAM.

10.1.14 Set Normal/Inverse Display (A6h/A7h)

This command sets the display to be either normal or inverse. In normal display a RAM data of 1 indicates an “ON” pixel while in inverse display a RAM data of 0 indicates an “ON” pixel.

10.1.15 Set Multiplex Ratio (A8h)

This command switches the default 63 multiplex mode to any multiplex ratio, ranging from 16 to 63. The output pads COM0~COM63 will be switched to the corresponding COM signal.

10.1.16 Reserved (AAh)

This command is reserved.

10.1.17 Dim Mode setting (ABh)

This command contains multiple bits to configure the contrast and brightness of color bank for the display in dim mode. The brightness setting of color bank can be set different to normal mode (AFh). The display can be set in dim mode through command ACh.

10.1.18 Master Configuration (ADh)

This command selects the external V_{CC} power supply by default. As external V_{CC} power supply is selected, external V_{CC} power should be connected to the V_{CC} pin.

10.1.19 Set Display ON/OFF (ACh/AEh/AFh)

These single byte commands are used to turn the OLED panel display ON or OFF.

When the display is ON, the selected circuits by Set Master Configuration command will be turned ON.

When the display is OFF, those circuits will be turned OFF and the segment and common output are in high impedance state.

These commands set the display to one of the three states:

- ACh : Dim Mode Display ON
- AEh : Display OFF
- AFh : Normal Brightness Display ON

where the dim mode settings are controlled by command ABh.

Figure 10-7 :Transition between different modes

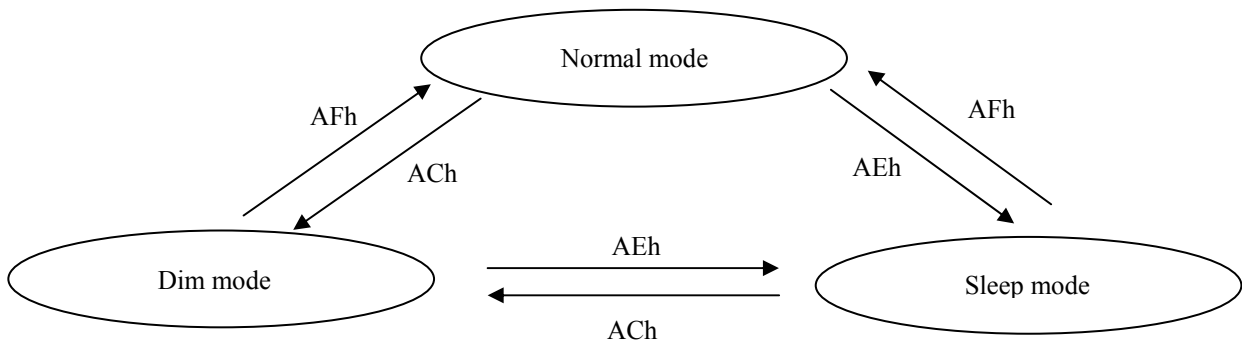

10.1.20 Set Page Start Address for Page Addressing Mode (B0h~B7h)

This command positions the page start address from 0 to 7 in GDDRAM under Page Addressing Mode. Please refer to Table 9-1 and Section 10.1.3 for details.

10.1.21 Set COM Output Scan Direction (C0h/C8h)

This command sets the scan direction of the COM output, allowing layout flexibility in the OLED module design. Additionally, the display will show once this command is issued. For example, if this command is sent during normal display then the graphic display will be vertically flipped immediately. Please refer to Table 10-3 for details.

10.1.22 Set Display Offset (D3h)

This is a double byte command. The second command specifies the mapping of the display start line to one of COM0~COM63 (assuming that COM0 is the display start line then the display start line register is equal to 0). For example, to move the COM16 towards the COM0 direction by 16 lines the 6-bit data in the second byte should be given as 010000b. To move in the opposite direction by 16 lines the 6-bit data should be given by 64 – 16, so the second byte would be 100000b.

The following two tables (Table 10-1, Table 10-2) show the example of setting the command C0h/C8h and D3h.

Table 10-1 : Example of Set Display Offset and Display Start Line with no Remap

Hardware pin name	Output												Set MUX ratio(A8h) COM Normal / Remapped (C0h / C8h) Display offset (D3h) Display start line (40h - 7Fh)
	64		64		64		56		56		56		
	Normal		Normal		Normal		Normal		Normal		Normal		
	0		8		0		0		8		8		
COM0	Row0	RAM0	Row8	RAM8	Row0	RAM8	Row0	RAM0	Row8	RAM8	Row0	RAM8	
COM1	Row1	RAM1	Row9	RAM9	Row1	RAM9	Row1	RAM1	Row9	RAM9	Row1	RAM9	
COM2	Row2	RAM2	Row10	RAM10	Row2	RAM10	Row2	RAM2	Row10	RAM10	Row2	RAM10	
COM3	Row3	RAM3	Row11	RAM11	Row3	RAM11	Row3	RAM3	Row11	RAM11	Row3	RAM11	
COM4	Row4	RAM4	Row12	RAM12	Row4	RAM12	Row4	RAM4	Row12	RAM12	Row4	RAM12	
COM5	Row5	RAM5	Row13	RAM13	Row5	RAM13	Row5	RAM5	Row13	RAM13	Row5	RAM13	
COM6	Row6	RAM6	Row14	RAM14	Row6	RAM14	Row6	RAM6	Row14	RAM14	Row6	RAM14	
COM7	Row7	RAM7	Row15	RAM15	Row7	RAM15	Row7	RAM7	Row15	RAM15	Row7	RAM15	
COM8	Row8	RAM8	Row16	RAM16	Row8	RAM16	Row8	RAM8	Row16	RAM16	Row8	RAM16	
COM9	Row9	RAM9	Row17	RAM17	Row9	RAM17	Row9	RAM9	Row17	RAM17	Row9	RAM17	
COM10	Row10	RAM10	Row18	RAM18	Row10	RAM18	Row10	RAM10	Row18	RAM18	Row10	RAM18	
COM11	Row11	RAM11	Row19	RAM19	Row11	RAM19	Row11	RAM11	Row19	RAM19	Row11	RAM19	
COM12	Row12	RAM12	Row20	RAM20	Row12	RAM20	Row12	RAM12	Row20	RAM20	Row12	RAM20	
COM13	Row13	RAM13	Row21	RAM21	Row13	RAM21	Row13	RAM13	Row21	RAM21	Row13	RAM21	
COM14	Row14	RAM14	Row22	RAM22	Row14	RAM22	Row14	RAM14	Row22	RAM22	Row14	RAM22	
COM15	Row15	RAM15	Row23	RAM23	Row15	RAM23	Row15	RAM15	Row23	RAM23	Row15	RAM23	
COM16	Row16	RAM16	Row24	RAM24	Row16	RAM24	Row16	RAM16	Row24	RAM24	Row16	RAM24	
COM17	Row17	RAM17	Row25	RAM25	Row17	RAM25	Row17	RAM17	Row25	RAM25	Row17	RAM25	
COM18	Row18	RAM18	Row26	RAM26	Row18	RAM26	Row18	RAM18	Row26	RAM26	Row18	RAM26	
COM19	Row19	RAM19	Row27	RAM27	Row19	RAM27	Row19	RAM19	Row27	RAM27	Row19	RAM27	
COM20	Row20	RAM20	Row28	RAM28	Row20	RAM28	Row20	RAM20	Row28	RAM28	Row20	RAM28	
COM21	Row21	RAM21	Row29	RAM29	Row21	RAM29	Row21	RAM21	Row29	RAM29	Row21	RAM29	
COM22	Row22	RAM22	Row30	RAM30	Row22	RAM30	Row22	RAM22	Row30	RAM30	Row22	RAM30	
COM23	Row23	RAM23	Row31	RAM31	Row23	RAM31	Row23	RAM23	Row31	RAM31	Row23	RAM31	
COM24	Row24	RAM24	Row32	RAM32	Row24	RAM32	Row24	RAM24	Row32	RAM32	Row24	RAM32	
COM25	Row25	RAM25	Row33	RAM33	Row25	RAM33	Row25	RAM25	Row33	RAM33	Row25	RAM33	
COM26	Row26	RAM26	Row34	RAM34	Row26	RAM34	Row26	RAM26	Row34	RAM34	Row26	RAM34	
COM27	Row27	RAM27	Row35	RAM35	Row27	RAM35	Row27	RAM27	Row35	RAM35	Row27	RAM35	
COM28	Row28	RAM28	Row36	RAM36	Row28	RAM36	Row28	RAM28	Row36	RAM36	Row28	RAM36	
COM29	Row29	RAM29	Row37	RAM37	Row29	RAM37	Row29	RAM29	Row37	RAM37	Row29	RAM37	
COM30	Row30	RAM30	Row38	RAM38	Row30	RAM38	Row30	RAM30	Row38	RAM38	Row30	RAM38	
COM31	Row31	RAM31	Row39	RAM39	Row31	RAM39	Row31	RAM31	Row39	RAM39	Row31	RAM39	
COM32	Row32	RAM32	Row40	RAM40	Row32	RAM40	Row32	RAM32	Row40	RAM40	Row32	RAM40	
COM33	Row33	RAM33	Row41	RAM41	Row33	RAM41	Row33	RAM33	Row41	RAM41	Row33	RAM41	
COM34	Row34	RAM34	Row42	RAM42	Row34	RAM42	Row34	RAM34	Row42	RAM42	Row34	RAM42	
COM35	Row35	RAM35	Row43	RAM43	Row35	RAM43	Row35	RAM35	Row43	RAM43	Row35	RAM43	
COM36	Row36	RAM36	Row44	RAM44	Row36	RAM44	Row36	RAM36	Row44	RAM44	Row36	RAM44	
COM37	Row37	RAM37	Row45	RAM45	Row37	RAM45	Row37	RAM37	Row45	RAM45	Row37	RAM45	
COM38	Row38	RAM38	Row46	RAM46	Row38	RAM46	Row38	RAM38	Row46	RAM46	Row38	RAM46	
COM39	Row39	RAM39	Row47	RAM47	Row39	RAM47	Row39	RAM39	Row47	RAM47	Row39	RAM47	
COM40	Row40	RAM40	Row48	RAM48	Row40	RAM48	Row40	RAM40	Row48	RAM48	Row40	RAM48	
COM41	Row41	RAM41	Row49	RAM49	Row41	RAM49	Row41	RAM41	Row49	RAM49	Row41	RAM49	
COM42	Row42	RAM42	Row50	RAM50	Row42	RAM50	Row42	RAM42	Row50	RAM50	Row42	RAM50	
COM43	Row43	RAM43	Row51	RAM51	Row43	RAM51	Row43	RAM43	Row51	RAM51	Row43	RAM51	
COM44	Row44	RAM44	Row52	RAM52	Row44	RAM52	Row44	RAM44	Row52	RAM52	Row44	RAM52	
COM45	Row45	RAM45	Row53	RAM53	Row45	RAM53	Row45	RAM45	Row53	RAM53	Row45	RAM53	
COM46	Row46	RAM46	Row54	RAM54	Row46	RAM54	Row46	RAM46	Row54	RAM54	Row46	RAM54	
COM47	Row47	RAM47	Row55	RAM55	Row47	RAM55	Row47	RAM47	Row55	RAM55	Row47	RAM55	
COM48	Row48	RAM48	Row56	RAM56	Row48	RAM56	Row48	RAM48	-	-	Row48	RAM56	
COM49	Row49	RAM49	Row57	RAM57	Row49	RAM57	Row49	RAM49	-	-	Row49	RAM57	
COM50	Row50	RAM50	Row58	RAM58	Row50	RAM58	Row50	RAM50	-	-	Row50	RAM58	
COM51	Row51	RAM51	Row59	RAM59	Row51	RAM59	Row51	RAM51	-	-	Row51	RAM59	
COM52	Row52	RAM52	Row60	RAM60	Row52	RAM60	Row52	RAM52	-	-	Row52	RAM60	
COM53	Row53	RAM53	Row61	RAM61	Row53	RAM61	Row53	RAM53	-	-	Row53	RAM61	
COM54	Row54	RAM54	Row62	RAM62	Row54	RAM62	Row54	RAM54	-	-	Row54	RAM62	
COM55	Row55	RAM55	Row63	RAM63	Row55	RAM63	Row55	RAM55	-	-	Row55	RAM63	
COM56	Row56	RAM56	Row0	RAM0	Row56	RAM0	-	-	Row0	RAM0	-	-	
COM57	Row57	RAM57	Row1	RAM1	Row57	RAM1	-	-	Row1	RAM1	-	-	
COM58	Row58	RAM58	Row2	RAM2	Row58	RAM2	-	-	Row2	RAM2	-	-	
COM59	Row59	RAM59	Row3	RAM3	Row59	RAM3	-	-	Row3	RAM3	-	-	
COM60	Row60	RAM60	Row4	RAM4	Row60	RAM4	-	-	Row4	RAM4	-	-	
COM61	Row61	RAM61	Row5	RAM5	Row61	RAM5	-	-	Row5	RAM5	-	-	
COM62	Row62	RAM62	Row6	RAM6	Row62	RAM6	-	-	Row6	RAM6	-	-	
COM63	Row63	RAM63	Row7	RAM7	Row63	RAM7	-	-	Row7	RAM7	-	-	

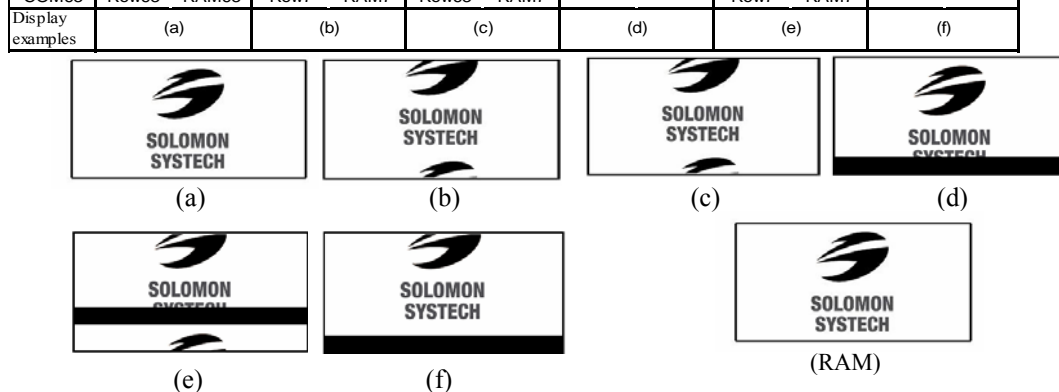
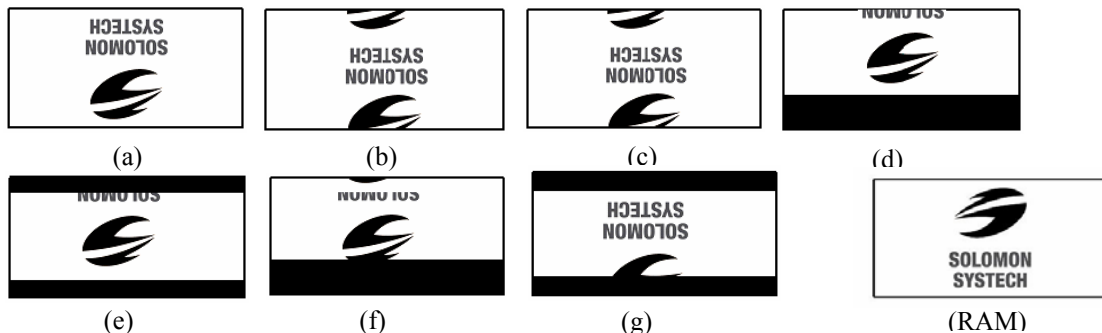

Table 10-2 :Example of Set Display Offset and Display Start Line with Remap

Hardw are pin name	Output												Set MUX ratio(A8h) COM Normal / Remapped (C0h / C8h) Display offset (D3h) Display start line (40h - 7Fh)				
	64			64			48			48				48			
	Remap			Remap			Remap			Remap				Remap			
	0			8			0			8				8			
0			0			8			0			8			16		
COM0	Row 63	RAM63	Row 7	RAM7	Row 63	RAM7	Row 47	RAM47	-	-	Row 47	RAM55	-	-			
COM1	Row 62	RAM62	Row 6	RAM6	Row 62	RAM6	Row 46	RAM46	-	-	Row 46	RAM54	-	-			
COM2	Row 61	RAM61	Row 5	RAM5	Row 61	RAM5	Row 45	RAM45	-	-	Row 45	RAM53	-	-			
COM3	Row 60	RAM60	Row 4	RAM4	Row 60	RAM4	Row 44	RAM44	-	-	Row 44	RAM52	-	-			
COM4	Row 59	RAM59	Row 3	RAM3	Row 59	RAM3	Row 43	RAM43	-	-	Row 43	RAM51	-	-			
COM5	Row 58	RAM58	Row 2	RAM2	Row 58	RAM2	Row 42	RAM42	-	-	Row 42	RAM50	-	-			
COM6	Row 57	RAM57	Row 1	RAM1	Row 57	RAM1	Row 41	RAM41	-	-	Row 41	RAM49	-	-			
COM7	Row 56	RAM56	Row 0	RAM0	Row 56	RAM0	Row 40	RAM40	-	-	Row 40	RAM48	-	-			
COM8	Row 55	RAM55	Row 63	RAM63	Row 55	RAM63	Row 39	RAM39	Row 47	RAM47	Row 39	RAM47	Row 47	RAM63			
COM9	Row 54	RAM54	Row 62	RAM62	Row 54	RAM62	Row 38	RAM38	Row 46	RAM46	Row 38	RAM46	Row 46	RAM62			
COM10	Row 53	RAM53	Row 61	RAM61	Row 53	RAM61	Row 37	RAM37	Row 45	RAM45	Row 37	RAM45	Row 45	RAM61			
COM11	Row 52	RAM52	Row 60	RAM60	Row 52	RAM60	Row 36	RAM36	Row 44	RAM44	Row 36	RAM44	Row 44	RAM60			
COM12	Row 51	RAM51	Row 59	RAM59	Row 51	RAM59	Row 35	RAM35	Row 43	RAM43	Row 35	RAM43	Row 43	RAM59			
COM13	Row 50	RAM50	Row 58	RAM58	Row 50	RAM58	Row 34	RAM34	Row 42	RAM42	Row 34	RAM42	Row 42	RAM58			
COM14	Row 49	RAM49	Row 57	RAM57	Row 49	RAM57	Row 33	RAM33	Row 41	RAM41	Row 33	RAM41	Row 41	RAM57			
COM15	Row 48	RAM48	Row 56	RAM56	Row 48	RAM56	Row 32	RAM32	Row 40	RAM40	Row 32	RAM40	Row 40	RAM56			
COM16	Row 47	RAM47	Row 55	RAM55	Row 47	RAM55	Row 31	RAM31	Row 39	RAM39	Row 31	RAM39	Row 39	RAM55			
COM17	Row 46	RAM46	Row 54	RAM54	Row 46	RAM54	Row 30	RAM30	Row 38	RAM38	Row 30	RAM38	Row 38	RAM54			
COM18	Row 45	RAM45	Row 53	RAM53	Row 45	RAM53	Row 29	RAM29	Row 37	RAM37	Row 29	RAM37	Row 37	RAM53			
COM19	Row 44	RAM44	Row 52	RAM52	Row 44	RAM52	Row 28	RAM28	Row 36	RAM36	Row 28	RAM36	Row 36	RAM52			
COM20	Row 43	RAM43	Row 51	RAM51	Row 43	RAM51	Row 27	RAM27	Row 35	RAM35	Row 27	RAM35	Row 35	RAM51			
COM21	Row 42	RAM42	Row 50	RAM50	Row 42	RAM50	Row 26	RAM26	Row 34	RAM34	Row 26	RAM34	Row 34	RAM50			
COM22	Row 41	RAM41	Row 49	RAM49	Row 41	RAM49	Row 25	RAM25	Row 33	RAM33	Row 25	RAM33	Row 33	RAM49			
COM23	Row 40	RAM40	Row 48	RAM48	Row 40	RAM48	Row 24	RAM24	Row 32	RAM32	Row 24	RAM32	Row 32	RAM48			
COM24	Row 39	RAM39	Row 47	RAM47	Row 39	RAM47	Row 23	RAM23	Row 31	RAM31	Row 23	RAM31	Row 31	RAM47			
COM25	Row 38	RAM38	Row 46	RAM46	Row 38	RAM46	Row 22	RAM22	Row 30	RAM30	Row 22	RAM30	Row 30	RAM46			
COM26	Row 37	RAM37	Row 45	RAM45	Row 37	RAM45	Row 21	RAM21	Row 29	RAM29	Row 21	RAM29	Row 29	RAM45			
COM27	Row 36	RAM36	Row 44	RAM44	Row 36	RAM44	Row 20	RAM20	Row 28	RAM28	Row 20	RAM28	Row 28	RAM44			
COM28	Row 35	RAM35	Row 43	RAM43	Row 35	RAM43	Row 19	RAM19	Row 27	RAM27	Row 19	RAM27	Row 27	RAM43			
COM29	Row 34	RAM34	Row 42	RAM42	Row 34	RAM42	Row 18	RAM18	Row 26	RAM26	Row 18	RAM26	Row 26	RAM42			
COM30	Row 33	RAM33	Row 41	RAM41	Row 33	RAM41	Row 17	RAM17	Row 25	RAM25	Row 17	RAM25	Row 25	RAM41			
COM31	Row 32	RAM32	Row 40	RAM40	Row 32	RAM40	Row 16	RAM16	Row 24	RAM24	Row 16	RAM24	Row 24	RAM40			
COM32	Row 31	RAM31	Row 39	RAM39	Row 31	RAM39	Row 15	RAM15	Row 23	RAM23	Row 15	RAM23	Row 23	RAM39			
COM33	Row 30	RAM30	Row 38	RAM38	Row 30	RAM38	Row 14	RAM14	Row 22	RAM22	Row 14	RAM22	Row 22	RAM38			
COM34	Row 29	RAM29	Row 37	RAM37	Row 29	RAM37	Row 13	RAM13	Row 21	RAM21	Row 13	RAM21	Row 21	RAM37			
COM35	Row 28	RAM28	Row 36	RAM36	Row 28	RAM36	Row 12	RAM12	Row 20	RAM20	Row 12	RAM20	Row 20	RAM36			
COM36	Row 27	RAM27	Row 35	RAM35	Row 27	RAM35	Row 11	RAM11	Row 19	RAM19	Row 11	RAM19	Row 19	RAM35			
COM37	Row 26	RAM26	Row 34	RAM34	Row 26	RAM34	Row 10	RAM10	Row 18	RAM18	Row 10	RAM18	Row 18	RAM34			
COM38	Row 25	RAM25	Row 33	RAM33	Row 25	RAM33	Row 9	RAM9	Row 17	RAM17	Row 9	RAM17	Row 17	RAM33			
COM39	Row 24	RAM24	Row 32	RAM32	Row 24	RAM32	Row 8	RAM8	Row 16	RAM16	Row 8	RAM16	Row 16	RAM32			
COM40	Row 23	RAM23	Row 31	RAM31	Row 23	RAM31	Row 7	RAM7	Row 15	RAM15	Row 7	RAM15	Row 15	RAM31			
COM41	Row 22	RAM22	Row 30	RAM30	Row 22	RAM30	Row 6	RAM6	Row 14	RAM14	Row 6	RAM14	Row 14	RAM30			
COM42	Row 21	RAM21	Row 29	RAM29	Row 21	RAM29	Row 5	RAM5	Row 13	RAM13	Row 5	RAM13	Row 13	RAM29			
COM43	Row 20	RAM20	Row 28	RAM28	Row 20	RAM28	Row 4	RAM4	Row 12	RAM12	Row 4	RAM12	Row 12	RAM28			
COM44	Row 19	RAM19	Row 27	RAM27	Row 19	RAM27	Row 3	RAM3	Row 11	RAM11	Row 3	RAM11	Row 11	RAM27			
COM45	Row 18	RAM18	Row 26	RAM26	Row 18	RAM26	Row 2	RAM2	Row 10	RAM10	Row 2	RAM10	Row 10	RAM26			
COM46	Row 17	RAM17	Row 25	RAM25	Row 17	RAM25	Row 1	RAM1	Row 9	RAM9	Row 1	RAM9	Row 9	RAM25			
COM47	Row 16	RAM16	Row 24	RAM24	Row 16	RAM24	Row 0	RAM0	Row 8	RAM8	Row 0	RAM8	Row 8	RAM24			
COM48	Row 15	RAM15	Row 23	RAM23	Row 15	RAM23	-	-	Row 7	RAM7	-	-	Row 7	RAM23			
COM49	Row 14	RAM14	Row 22	RAM22	Row 14	RAM22	-	-	Row 6	RAM6	-	-	Row 6	RAM22			
COM50	Row 13	RAM13	Row 21	RAM21	Row 13	RAM21	-	-	Row 5	RAM5	-	-	Row 5	RAM21			
COM51	Row 12	RAM12	Row 20	RAM20	Row 12	RAM20	-	-	Row 4	RAM4	-	-	Row 4	RAM20			
COM52	Row 11	RAM11	Row 19	RAM19	Row 11	RAM19	-	-	Row 3	RAM3	-	-	Row 3	RAM19			
COM53	Row 10	RAM10	Row 18	RAM18	Row 10	RAM18	-	-	Row 2	RAM2	-	-	Row 2	RAM18			
COM54	Row 9	RAM9	Row 17	RAM17	Row 9	RAM17	-	-	Row 1	RAM1	-	-	Row 1	RAM17			
COM55	Row 8	RAM8	Row 16	RAM16	Row 8	RAM16	-	-	Row 0	RAM0	-	-	Row 0	RAM16			
COM56	Row 7	RAM7	Row 15	RAM15	Row 7	RAM15	-	-	-	-	-	-	-	-			
COM57	Row 6	RAM6	Row 14	RAM14	Row 6	RAM14	-	-	-	-	-	-	-	-			
COM58	Row 5	RAM5	Row 13	RAM13	Row 5	RAM13	-	-	-	-	-	-	-	-			
COM59	Row 4	RAM4	Row 12	RAM12	Row 4	RAM12	-	-	-	-	-	-	-	-			
COM60	Row 3	RAM3	Row 11	RAM11	Row 3	RAM11	-	-	-	-	-	-	-	-			
COM61	Row 2	RAM2	Row 10	RAM10	Row 2	RAM10	-	-	-	-	-	-	-	-			
COM62	Row 1	RAM1	Row 9	RAM9	Row 1	RAM9	-	-	-	-	-	-	-	-			
COM63	Row 0	RAM0	Row 8	RAM8	Row 0	RAM8	-	-	-	-	-	-	-	-			



10.1.23 Set Display Clock Divide Ratio/ Oscillator Frequency (D5h)

This command consists of two functions:

- Display Clock Divide Ratio (D)(A[3:0])
Set the divide ratio to generate DCLK (Display Clock) from CLK. The divide ratio is from 1 to 16, with reset value = 1. Please refer to section 8.3 for the details relationship of DCLK and CLK.
- Oscillator Frequency (A[7:4])
Program the oscillator frequency Fosc that is the source of CLK if CLS pin is pulled high. The 4-bit value results in 16 different frequency settings available as shown below. The default setting is 0111b.

Figure 10-8 : Typical Oscillator frequency adjustment by D5 command ($V_{DD} = 2.8V$)

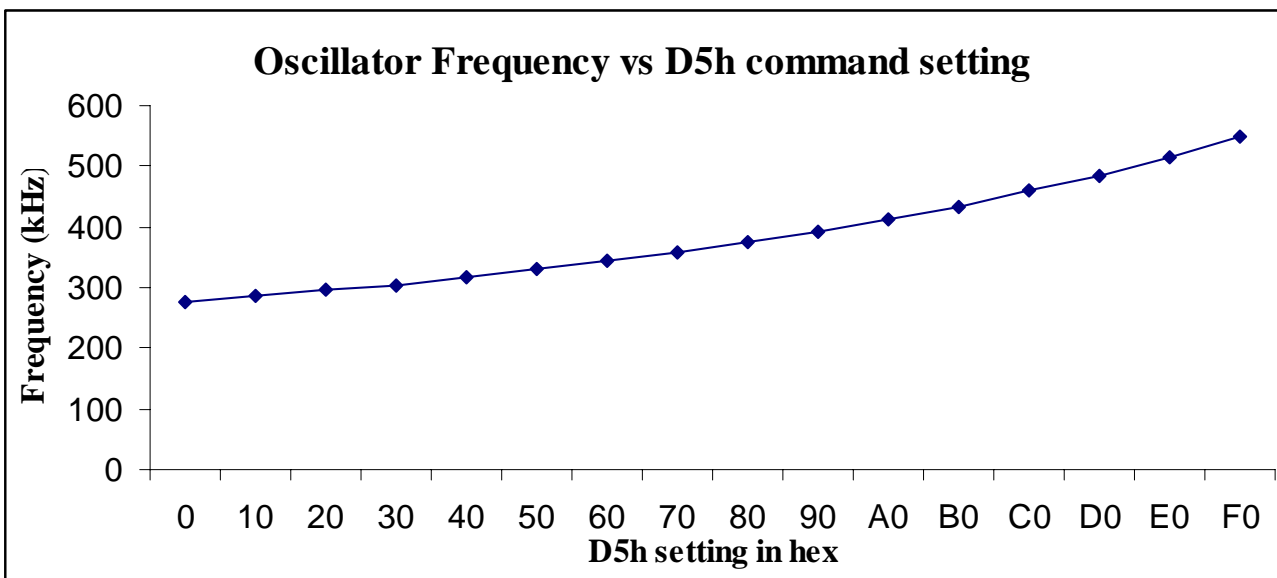

Note

⁽¹⁾ There is 10% tolerance in the above frequency values

10.1.24 Set Area Color Mode ON/OFF & Low Power Display Mode (D8h)

This command is used to enable area color mode. RESET is monochrome mode. The low power display mode can reduce power consumption during IC operation.

10.1.25 Set Pre-charge Period (D9h)

This command is used to set the duration of the pre-charge period. The interval is counted in number of DCLK, where RESET equals 2 DCLKs.

10.1.26 Set COM Pins Hardware Configuration (DAh)

This command sets the COM signals pin configuration to match the OLED panel hardware layout. The table below shows the COM pin configuration under different conditions (for MUX ratio =64):

Table 10-3 : COM Pins Hardware Configuration

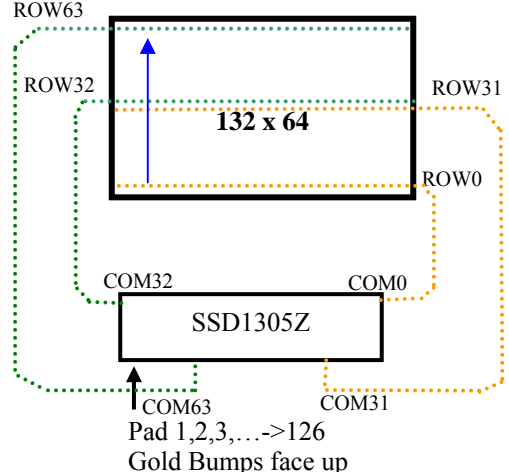
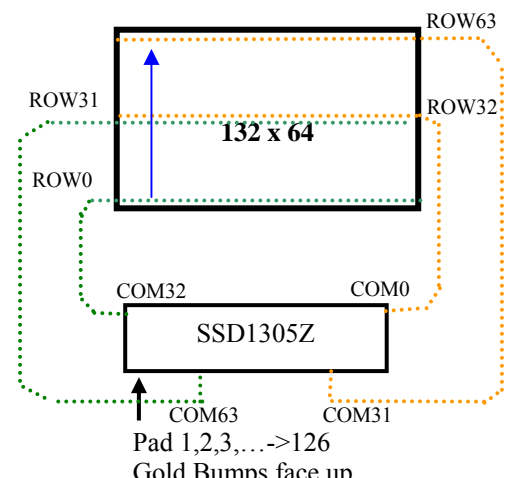
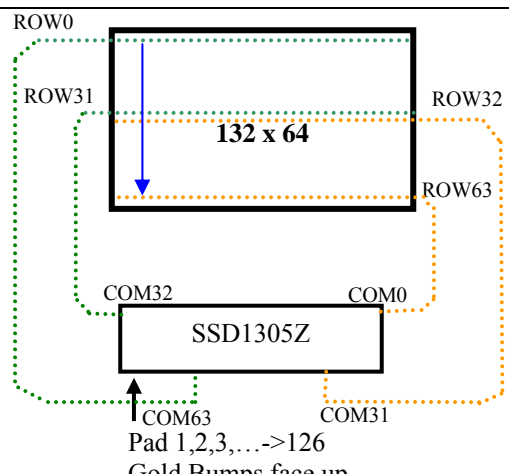
Conditions	COM pins Configurations
<p>1 Sequential COM pin configuration (DAh X[4] =0) COM output Scan direction: from COM0 to COM63 (C0h) Disable COM Left/Right remap (DAh X[5] =0)</p>	 <p>Pad 1,2,3,...->126 Gold Bumps face up</p>
<p>2 Sequential COM pin configuration (DAh X[4] =0) COM output Scan direction: from COM0 to COM63 (C0h) Enable COM Left/Right remap (DAh X[5] =1)</p>	 <p>Pad 1,2,3,...->126 Gold Bumps face up</p>
<p>3 Sequential COM pin configuration (DAh X[4] =0) COM output Scan direction: from COM63 to COM0 (C8h) Disable COM Left/Right remap (DAh X[5] =0)</p>	 <p>Pad 1,2,3,...->126 Gold Bumps face up</p>

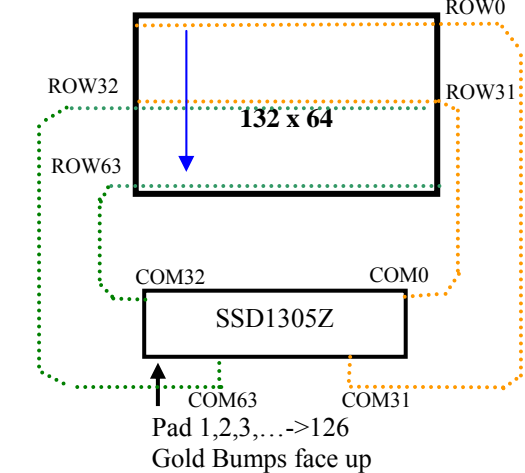
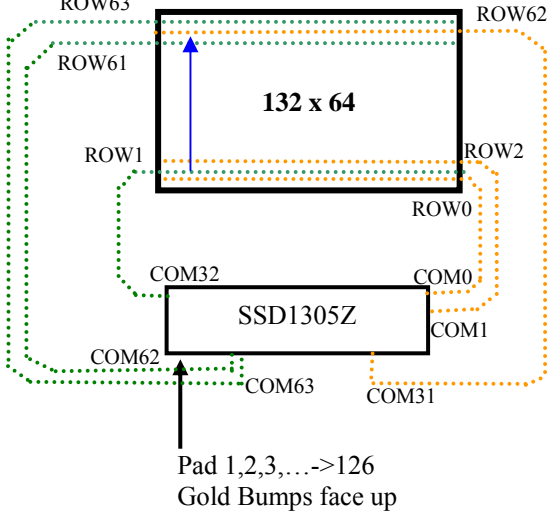
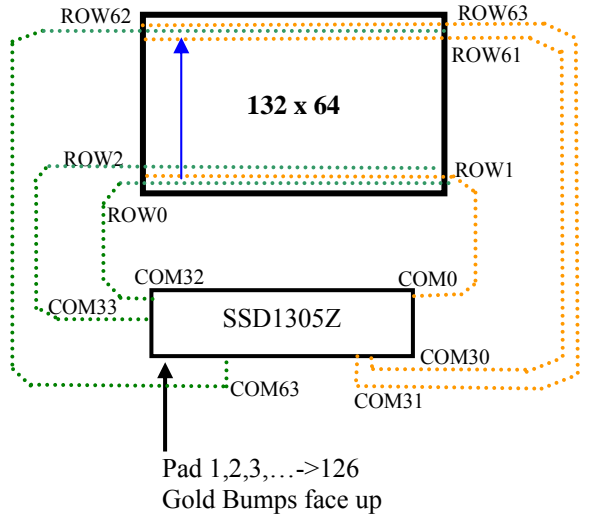
Conditions	COM pins Configurations
<p>4 Sequential COM pin configuration (DAh X[4] =0) COM output Scan direction: from COM63 to COM0 (C8h) Enable COM Left/Right remap (DAh X[5] =1)</p>	
<p>5 Alternative COM pin configuration (DAh X[4] =1) COM output Scan direction: from COM0 to COM63 (C0h) Disable COM Left/Right remap (DAh X[5] =0)</p>	
<p>6 Alternative COM pin configuration (DAh X[4] =1) COM output Scan direction: from COM0 to COM63 (C0h) Enable COM Left/Right remap (DAh X[5] =1)</p>	

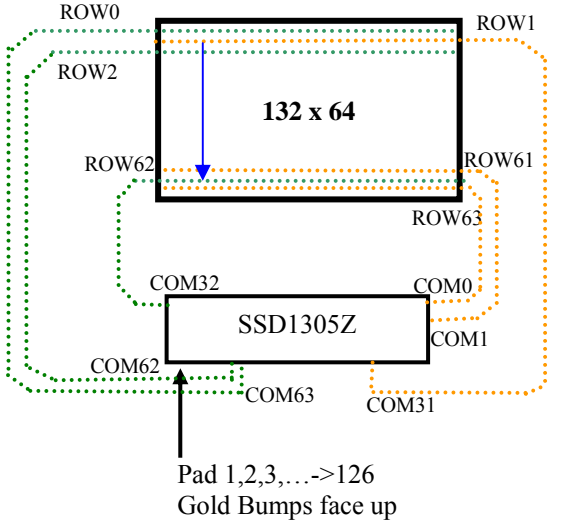
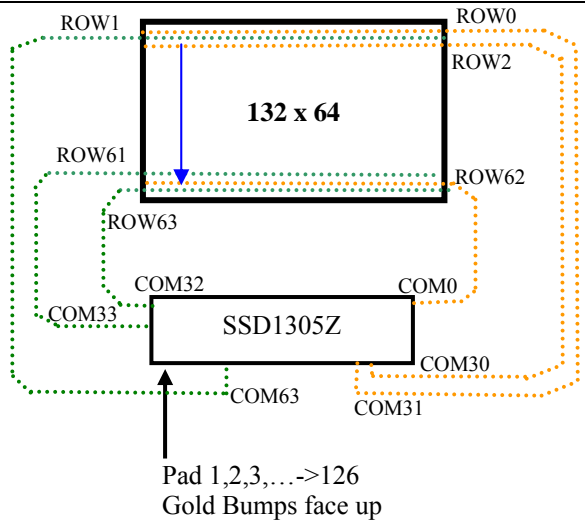
Conditions	COM pins Configurations
7 Alternative COM pin configuration (DAh X[4] =1) COM output Scan direction: from COM63 to COM0(C8h) Disable COM Left/Right remap (DAh X[5] =0)	
8 Alternative COM pin configuration (DAh X[4] =1) COM output Scan direction: from COM63 to COM0(C8h) Enable COM Left/Right remap (DAh X[5] =1)	

10.1.27 Set V_{COMH} Deselect Level (DBh)

This command adjusts the V_{COMH} regulator output.

10.1.28 Enter Read Modify Write (E0h)

This single byte command is used to enter the Read Modify Write mode.

During the Read Modify Write mode:

The RAM address pointer will not be incremented when there is data read.

The RAM address pointer will be increased by one automatically after each data write.

After exit the Read Modify Write Mode by command EEh, the RAM address pointer returns back to the original location before enter the Read Modify Write mode.

For instance, when reading the data from the RAM and re-writing a new data to the same location, there is no need to re-enter the column and page addresses again under this mode.

Table 10-4 : Example of Read Modify Write Mode

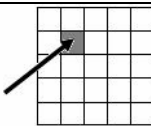
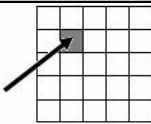
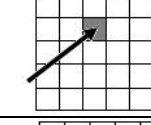
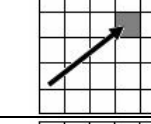
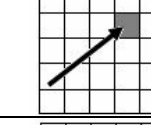
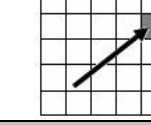
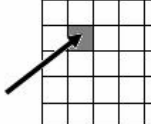
Condition	RAM & address pointer (under Horizontal addressing mode)
Originally, Address Pointer point to address A	
Enter Read Modify Write Mode by command E0h	
Data read : address pointer does not change	
Data Write: address pointer increases by one automatically after each data write	
Data Write: address pointer increases by one automatically after each data write	
Data read : address pointer does not change	
Data Write: address pointer increases by one automatically after each data write	
Exit Read Modify Write Mode by command EEh	
Address Pointer point to address A after exit Read Modify Write Mode	

10.1.29 NOP (E3h)

No Operation Command

10.1.30 Exit Read Modify Write (EEh)

This single byte command is used to exit the Read Modify Write mode (Please refer to Section 10.1.28. for details of the Read Modify Write Mode).

10.1.31 Status register Read

This command is issued by setting D/C# ON LOW during a data read (See Figure 13-1 to Figure 13-3 for parallel interface waveform). It allows the MCU to monitor the internal status of the chip. No status read is provided for serial mode.

10.2 Graphic Acceleration Command

10.2.1 Horizontal Scroll Setup (26h/27h)

This command consists of 5 consecutive bytes to set up the horizontal scroll parameters and determines the scrolling start page, end page and scrolling speed.

Before issuing this command the horizontal scroll must be deactivated (2Eh). Otherwise, RAM content may be corrupted.

The SSD1305 horizontal scroll is designed for 132 columns scrolling. The following three figures (Figure 10-9, Figure 10-10, Figure 10-11) show the examples of using the horizontal scroll:

Figure 10-9 : Horizontal scroll example: Scroll RIGHT by 4 columns

Original Setting	SEG0	SEG1	SEG2	SEG3	SEG4	SEG5	SEG126	SEG127	SEG128	SEG129	SEG130	SEG131
After one scroll step	SEG128	SEG129	SEG130	SEG131	SEG0	SEG1	SEG122	SEG123	SEG124	SEG125	SEG126	SEG127

Figure 10-10 : Horizontal scroll example: Scroll LEFT by 2 columns

Original Setting	SEG0	SEG1	SEG2	SEG3	SEG4	SEG5	SEG126	SEG127	SEG128	SEG129	SEG130	SEG131
After one scroll step	SEG2	SEG3	SEG4	SEG5	SEG6	SEG7	SEG128	SEG129	SEG130	SEG131	SEG0	SEG1

Figure 10-11 : Horizontal scrolling setup example

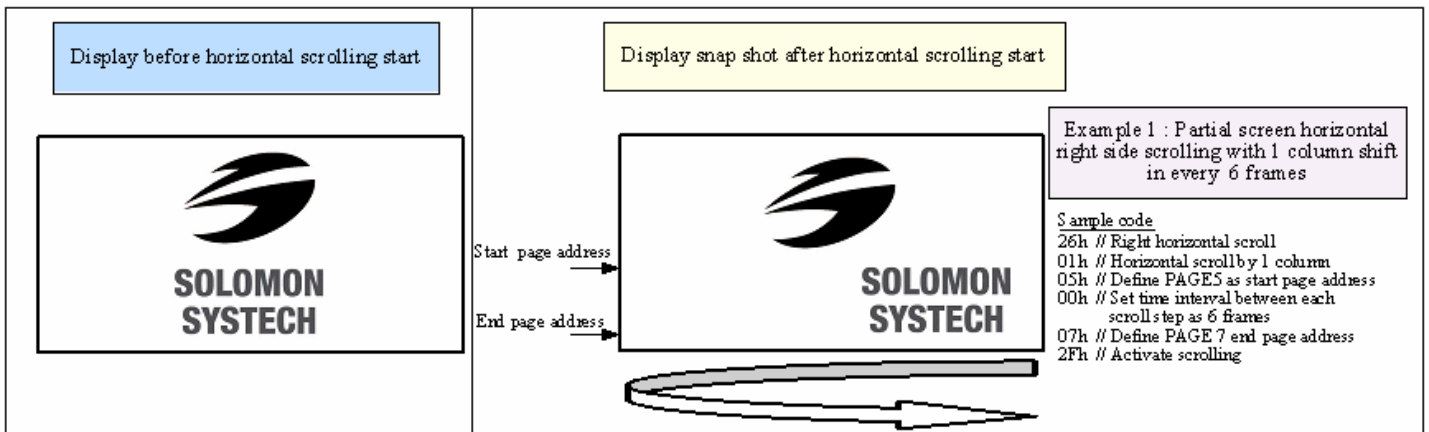

10.2.2 Continuous Vertical and Horizontal Scroll Setup (29h/2Ah)

This command consists of 6 consecutive bytes to set up the continuous vertical and horizontal scroll parameters and determines the scrolling start page, end page, scrolling speed and vertical scrolling offset.

The bytes A[2:0], B[2:0], C[2:0] and D[2:0] of command 29h/2Ah are for the setting of the continuous horizontal scrolling. The byte E[5:0] is for the setting of the continuous vertical scrolling offset. All these bytes together are for the setting of continuous diagonal (horizontal + vertical) scrolling. If the vertical scrolling offset byte E[5:0] is set to zero, then only horizontal scrolling is performed (like command 26/27h). Alternatively, if the byte A[2:0] is set to zero and E[5:0] is not set to zero, then only vertical scrolling is performed.

Before issuing this command the scroll must be deactivated (2Eh). Otherwise, RAM content may be corrupted. The following two figures (Figure 10-12 , Figure 10-13) show the examples of using the continuous vertical and horizontal scroll:

Figure 10-12 : Continuous Vertical and Horizontal scrolling setup examples

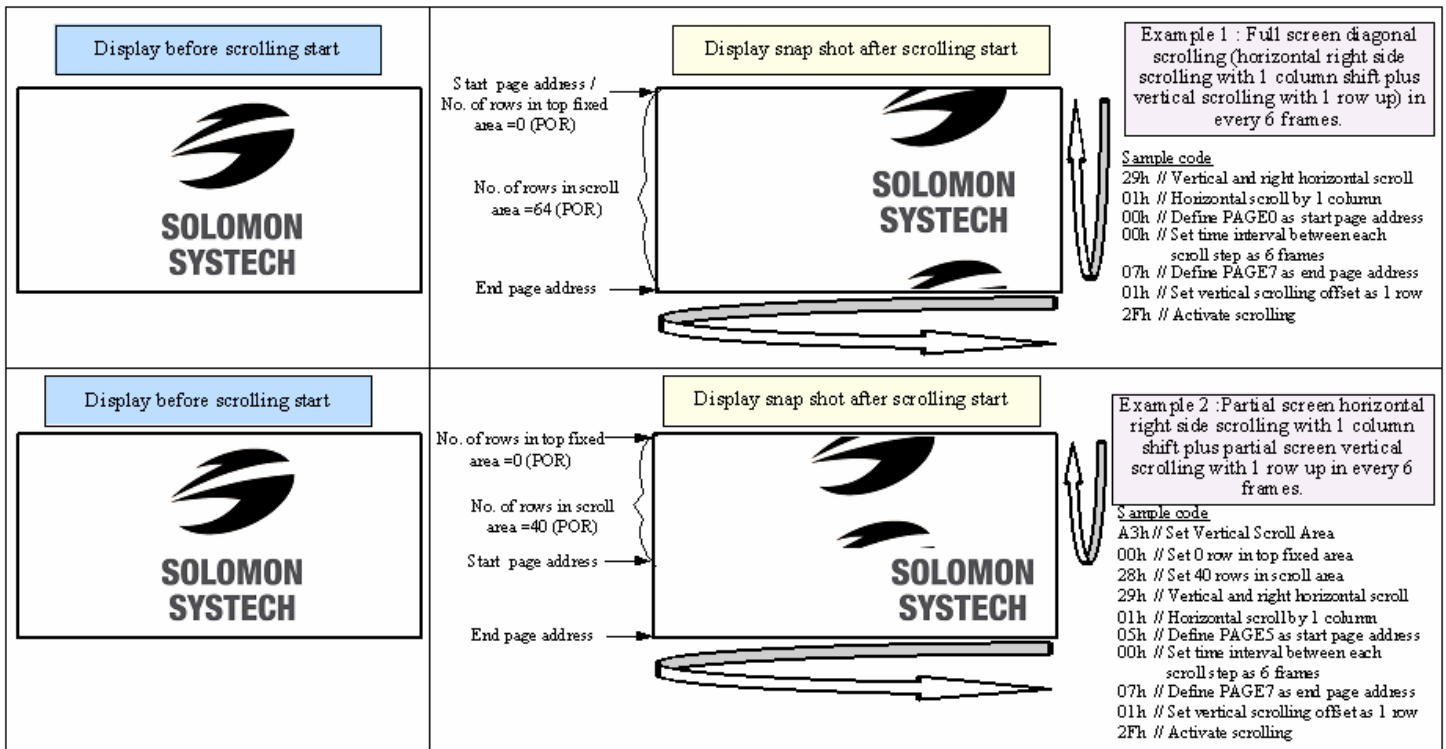
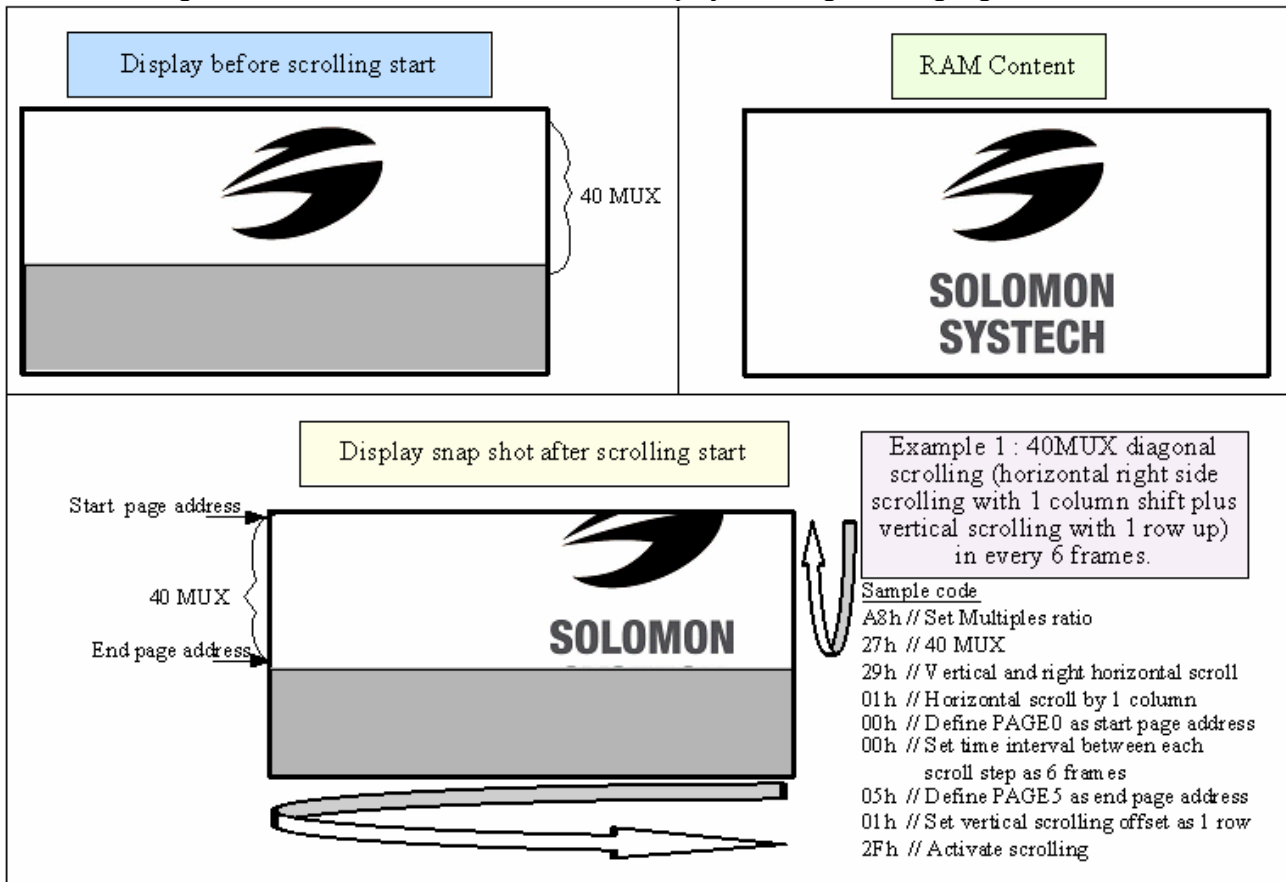

Figure 10-13 : Continuous Vertical and Horizontal scrolling example: With setting in MUX ratio

As shown in Figure 10-13, the whole RAM content is displayed during scrolling regardless of the MUX ratio.



10.2.3 Deactivate Scroll (2Eh)

This command stops the motion of scrolling. After sending 2Eh command to deactivate the scrolling action, the ram data needs to be rewritten.

10.2.4 Activate Scroll (2Fh)

This command starts the motion of scrolling and should only be issued after the scroll setup parameters have been defined by the scrolling setup commands :26h/27h/29h/2Ah . The setting in the last scrolling setup command overwrites the setting in the previous scrolling setup commands.









The following actions are prohibited after the scrolling is activated

1. RAM access (Data write or read)
2. Changing the horizontal scroll setup parameters

10.2.5 Set Vertical Scroll Area(A3h)

This command consists of 3 consecutive bytes to set up the vertical scroll area. For the continuous vertical scroll function (command 29/2Ah), the number of rows that in vertical scrolling can be set smaller or equal to the MUX ratio. Figure 10-14 shows some vertical scrolling example with different settings in vertical scroll area.

Figure 10-14 : Vertical scroll area setup examples

Display before vertical scrolling start	Display snap shot after vertical scrolling start	
	<p>No. of rows in top fixed area =0 (POR)</p> <p>No. of rows in scroll area=64 (POR)</p> 	<p>Example 1 : Full screen vertical scrolling with 1 row up in every 6 frames</p> <p>Sample code 29h // Vertical and right horizontal scroll 00h // No horizontal scroll 00h // Dummy byte for start page address 00h // Set time interval between each scroll step as 6 frames 00h // Dummy byte for end page address 01h // Set vertical scrolling offset as 1 row 2Fh // Activate scrolling</p>
	<p>No. of rows in top fixed area=0</p> <p>No. of rows in scroll area=40</p> 	<p>Example 2 : Partial screen (top area) vertical scrolling with 1 row up in every 32 frames</p> <p>Sample code A3h // Set Vertical Scroll Area 00h // Set 0 row in top fixed area 28h // Set 40 rows in scroll area 29h // Vertical and right horizontal scroll 00h // No horizontal scroll 00h // Dummy byte for start page address 01h // Set time interval between each scroll step as 32 frames 00h // Dummy byte for end page address 01h // Set vertical scrolling offset as 1 row 2Fh // Activate scrolling</p>
	<p>No. of rows in top fixed area=40</p> <p>No. of rows in scroll area=24</p> 	<p>Example 3 : Partial screen (bottom area) vertical scrolling with 1 row up in every 6 frames</p> <p>Sample code A3h // Set Vertical Scroll Area 28h // Set 40 rows in top fixed area 18h // Set 24 rows in scroll area 29h // Vertical and right horizontal scroll 00h // No horizontal scroll 00h // Dummy byte for start page address 00h // Set time interval between each scroll step as 6 frames 00h // Dummy byte for end page address 01h // Set vertical scrolling offset as 1 row 2Fh // Activate scrolling</p>
	<p>No. of rows in top fixed area=32</p> <p>No. of rows in scroll area=24</p> 	<p>Example 4 : Partial screen (central area) vertical scrolling with 1 row up in every 3 frames</p> <p>Sample code A3h // Set Vertical Scroll Area 20h // Set 32 rows in top fixed area 18h // Set 24 rows in scroll area 29h // Vertical and right horizontal scroll 00h // No horizontal scroll 00h // Dummy byte for start page address 04h // Set time interval between each scroll step as 3 frames 00h // Dummy byte for end page address 01h // Set vertical scrolling offset as 1 row 2Fh // Activate scrolling</p>

11 MAXIMUM RATINGS

Table 11-1 : Maximum Ratings (Voltage Referenced to V_{SS})

Symbol	Parameter	Value	Unit
V_{DD}	Supply Voltage	-0.3 to +4	V
V_{DDIO}		-0.3 to $V_{DD}+0.5$	V
V_{CC}		0 to 16	V
V_{SEG}	SEG output voltage	0 to V_{CC}	V
V_{COM}	COM output voltage	0 to $0.9 \cdot V_{CC}$	V
V_{in}	Input voltage	$V_{SS}-0.3$ to $V_{DD}+0.3$	V
T_A	Operating Temperature	-40 to +85	°C
T_{stg}	Storage Temperature Range	-65 to +150	°C

Maximum ratings are those values beyond which damages to the device may occur. Functional operation should be restricted to the limits in the Electrical Characteristics tables or Pin Description section

This device may be light sensitive. Caution should be taken to avoid exposure of this device to any light source during normal operation. This device is not radiation protected.

12 DC CHARACTERISTICS

Condition (Unless otherwise specified):

Voltage referenced to V_{SS}

$V_{DD} = 2.4$ to $3.5V$

$T_A = 25^\circ C$

Table 12-1 : DC Characteristics

Symbol	Parameter	Test Condition	Min	Typ	Max	Unit
V_{CC}	Operating Voltage	-	7	-	15	V
V_{DD}	Logic Supply Voltage	-	2.4	-	3.5	V
V_{DDIO}	Logic Supply Voltage for MCU interface	-	1.6	-	V_{DD}	V
V_{OH}	High Logic Output Level	$I_{OUT} = 100\mu A, 3.3MHz$	$0.9 \times V_{DDIO}$	-	-	V
V_{OL}	Low Logic Output Level	$I_{OUT} = 100\mu A, 3.3MHz$	-	-	$0.1 \times V_{DDIO}$	V
V_{IH}	High Logic Input Level	-	$0.8 \times V_{DDIO}$	-	-	V
V_{IL}	Low Logic Input Level	-	-	-	$0.2 \times V_{DDIO}$	V
$I_{CC, SLEEP}$	I_{CC} Sleep mode Current	$V_{DDIO} = 1.6V \sim 3.3V, V_{DD} = 2.4V \sim 3.5V, V_{CC} = 7V \sim 15V$ Display OFF, No panel attached	-	-	10	μA
$I_{DD, SLEEP}$	I_{DD} Sleep mode Current	$V_{DDIO} = 1.6V \sim 3.3V, V_{DD} = 2.4V \sim 3.5V, V_{CC} = 7V \sim 15V$ Display OFF, No panel attached	-	-	10	μA
$I_{DDIO, SLEEP}$	I_{DDIO} Sleep mode Current	$V_{DDIO} = 1.6V \sim 3.3V, V_{DD} = 2.4V \sim 3.5V, V_{CC} = 7V \sim 15V$ Display OFF, No panel attached	-	-	10	μA
I_{CC}	V_{CC} Supply Current $V_{DD} = 2.7V, V_{CC} = 12V,$ $I_{REF} = 10\mu A$ No loading, Display ON, All ON	Contrast = FFh	-	550	1000	μA
I_{DD}	V_{DD} Supply Current $V_{DD} = 2.7V, V_{CC} = 12V,$ $I_{REF} = 10\mu A$ No loading, Display ON, All ON		-	100	300	μA
I_{SEG}	Segment Output Current $V_{DD} = 2.7V, V_{CC} = 12V,$ $I_{REF} = 10\mu A, Display ON.$	Contrast=FFh	294	320	346	μA
		Contrast=AFh	-	220	-	
		Contrast=7Fh	-	159	-	
		Contrast=3Fh	-	79	-	
		Contrast=0Fh	-	19	-	
Dev	Segment output current uniformity	$Dev = (I_{SEG} - I_{MID}) / I_{MID}$ $I_{MID} = (I_{MAX} + I_{MIN}) / 2$ $I_{SEG}[0:131] = \text{Segment current at contrast} = FFh$	-3	-	+3	%
Adj. Dev	Adjacent pin output current uniformity (contrast = FF)	$Adj Dev = (I[n] - I[n+1]) / (I[n] + I[n+1])$	-2	-	+2	%

13 AC CHARACTERISTICS

Conditions:

Voltage referenced to V_{SS}

V_{DD} =2.4 to 3.5V

T_A = 25°C

Table 13-1 : AC Characteristics

Symbol	Parameter	Test Condition	Min	Typ	Max	Unit
FOSC ⁽¹⁾	Oscillation Frequency of Display Timing Generator	$V_{DD} = 2.8V$	324	360	396	kHz
FFRM	Frame Frequency for 64 MUX Mode	132x64 Graphic Display Mode, Display ON, Internal Oscillator Enabled	-	$F_{OSC} \times 1/(DxKx64)$ ⁽²⁾	-	Hz
RES#	Reset low pulse width		3	-	-	us

Note

⁽¹⁾ Fosc stands for the frequency value of the internal oscillator and the value is measured when command D5h A[7:4] is in default value.

⁽²⁾ D: divide ratio (default value = 1)

K: number of display clocks (default value = 54)

Please refer to Table 9-1 (Set Display Clock Divide Ratio/Oscillator Frequency, D5h) for detailed description

Table 13-2 : 6800-Series MCU Parallel Interface Timing Characteristics

($V_{DD} - V_{SS} = 2.4V$ to $3.5V$, $V_{DDIO} = V_{DD}$, $T_A = 25^\circ C$)

Symbol	Parameter	Min	Typ	Max	Unit
t_{cycle}	Clock Cycle Time	300	-	-	ns
t_{AS}	Address Setup Time	0	-	-	ns
t_{AH}	Address Hold Time	0	-	-	ns
t_{DSW}	Write Data Setup Time	40	-	-	ns
t_{DHW}	Write Data Hold Time	7	-	-	ns
t_{DHR}	Read Data Hold Time	20	-	-	ns
t_{OH}	Output Disable Time	-	-	70	ns
t_{ACC}	Access Time	-	-	140	ns
PW_{CSL}	Chip Select Low Pulse Width (read) Chip Select Low Pulse Width (write)	120 60	-	-	ns
PW_{CSH}	Chip Select High Pulse Width (read) Chip Select High Pulse Width (write)	60 60	-	-	ns
t_R	Rise Time	-	-	40	ns
t_F	Fall Time	-	-	40	ns

Figure 13-1 : 6800-series MCU parallel interface characteristics

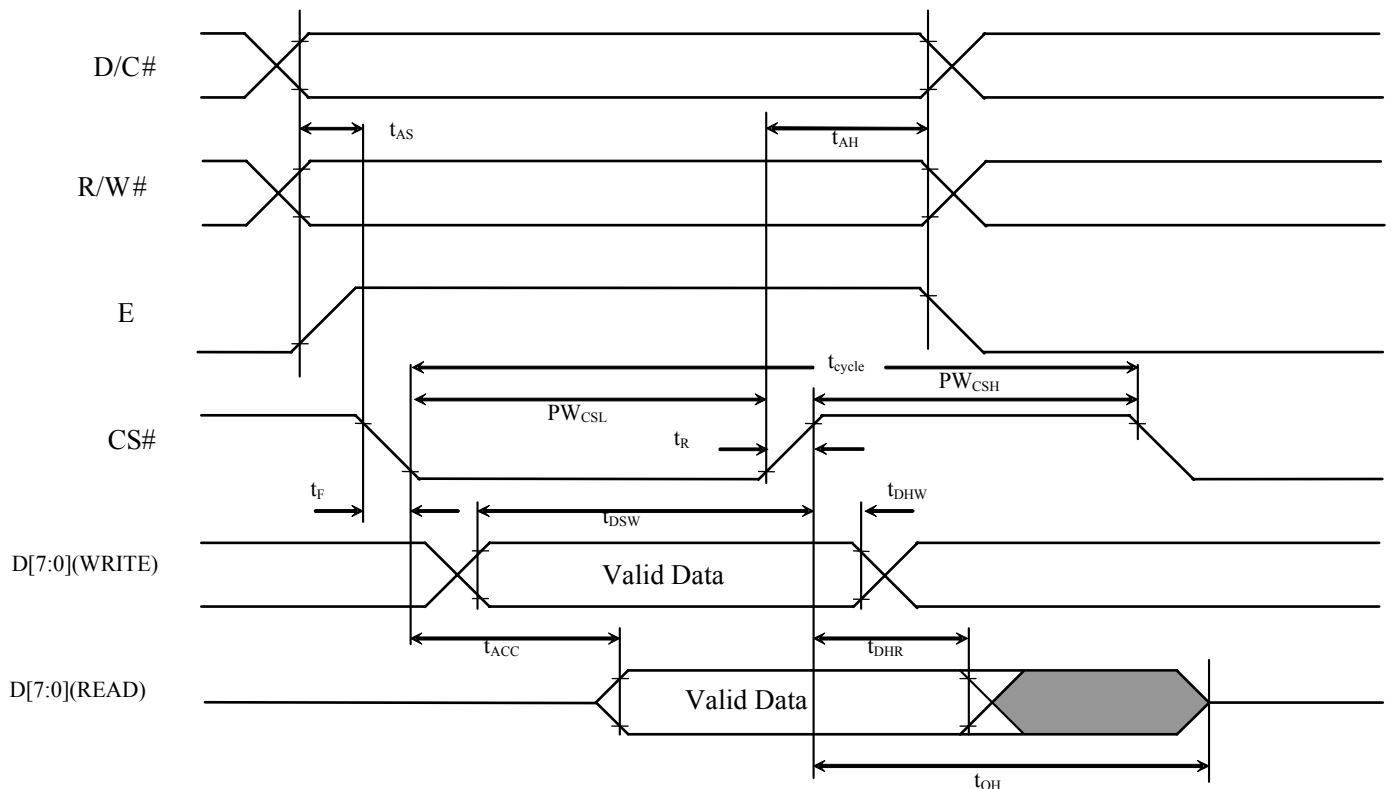

Table 13-3 : 8080-Series MCU Parallel Interface Timing Characteristics

($V_{DD} - V_{SS} = 2.4V$ to $3.5V$, $V_{DDIO} = V_{DD}$, $T_A = 25^\circ C$)

Symbol	Parameter	Min	Typ	Max	Unit
t_{cclk}	Clock Cycle Time	300	-	-	ns
t_{AS}	Address Setup Time	10	-	-	ns
t_{AH}	Address Hold Time	0	-	-	ns
t_{DSW}	Write Data Setup Time	40	-	-	ns
t_{DHW}	Write Data Hold Time	7	-	-	ns
t_{DHR}	Read Data Hold Time	20	-	-	ns
t_{OH}	Output Disable Time	-	-	70	ns
t_{ACC}	Access Time	-	-	140	ns
$t_{PWL R}$	Read Low Time	120	-	-	ns
$t_{PWL W}$	Write Low Time	60	-	-	ns
$t_{PWH R}$	Read High Time	60	-	-	ns
$t_{PWH W}$	Write High Time	60	-	-	ns
t_R	Rise Time	-	-	40	ns
t_F	Fall Time	-	-	40	ns
t_{CS}	Chip select setup time	0	-	-	ns
t_{CSH}	Chip select hold time to read signal	0	-	-	ns
t_{CSF}	Chip select hold time	20	-	-	ns

Figure 13-2 : 8080-series parallel interface characteristics (Form 1)

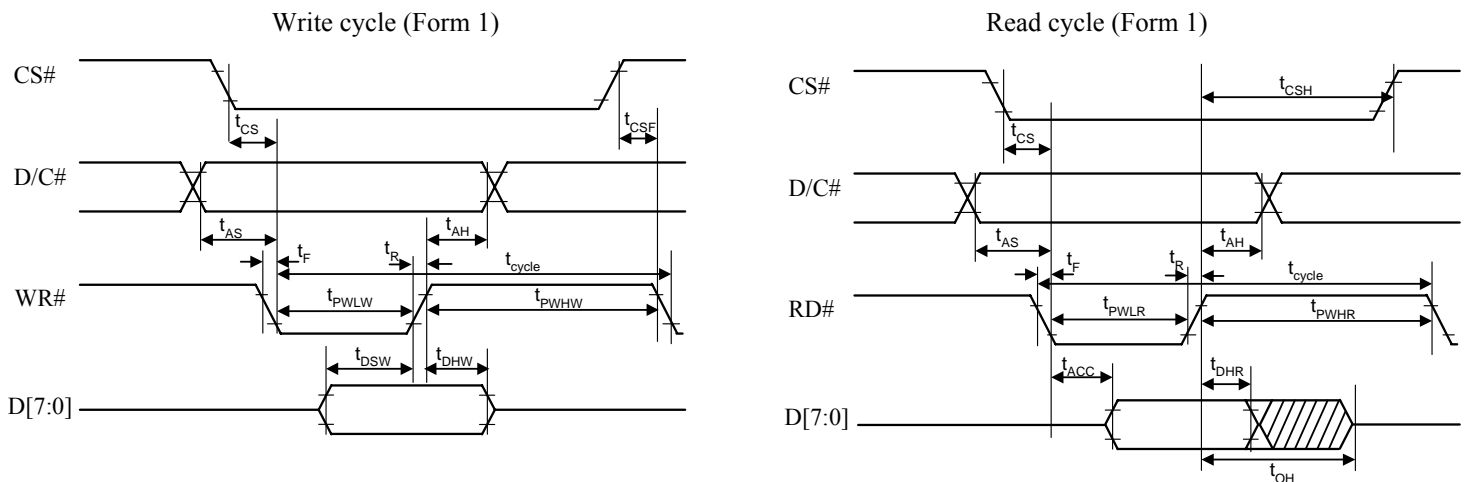

Figure 13-3 : 8080-series parallel interface characteristics (Form 2)

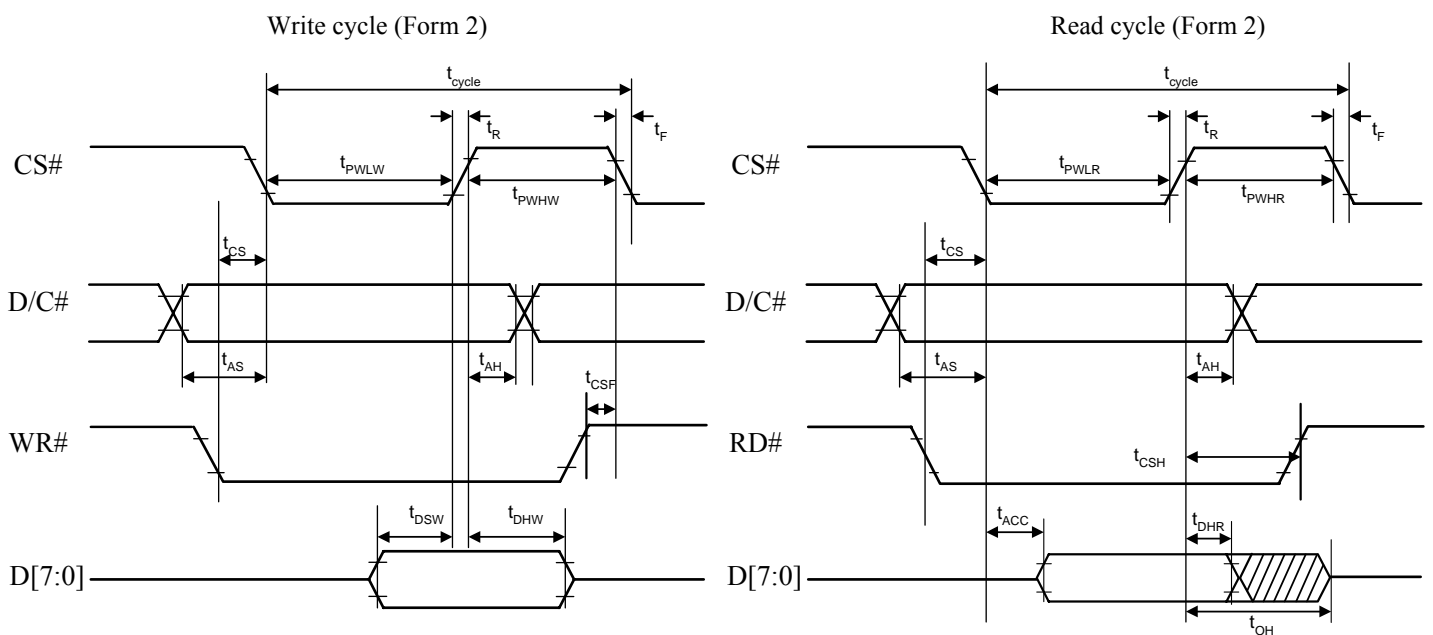
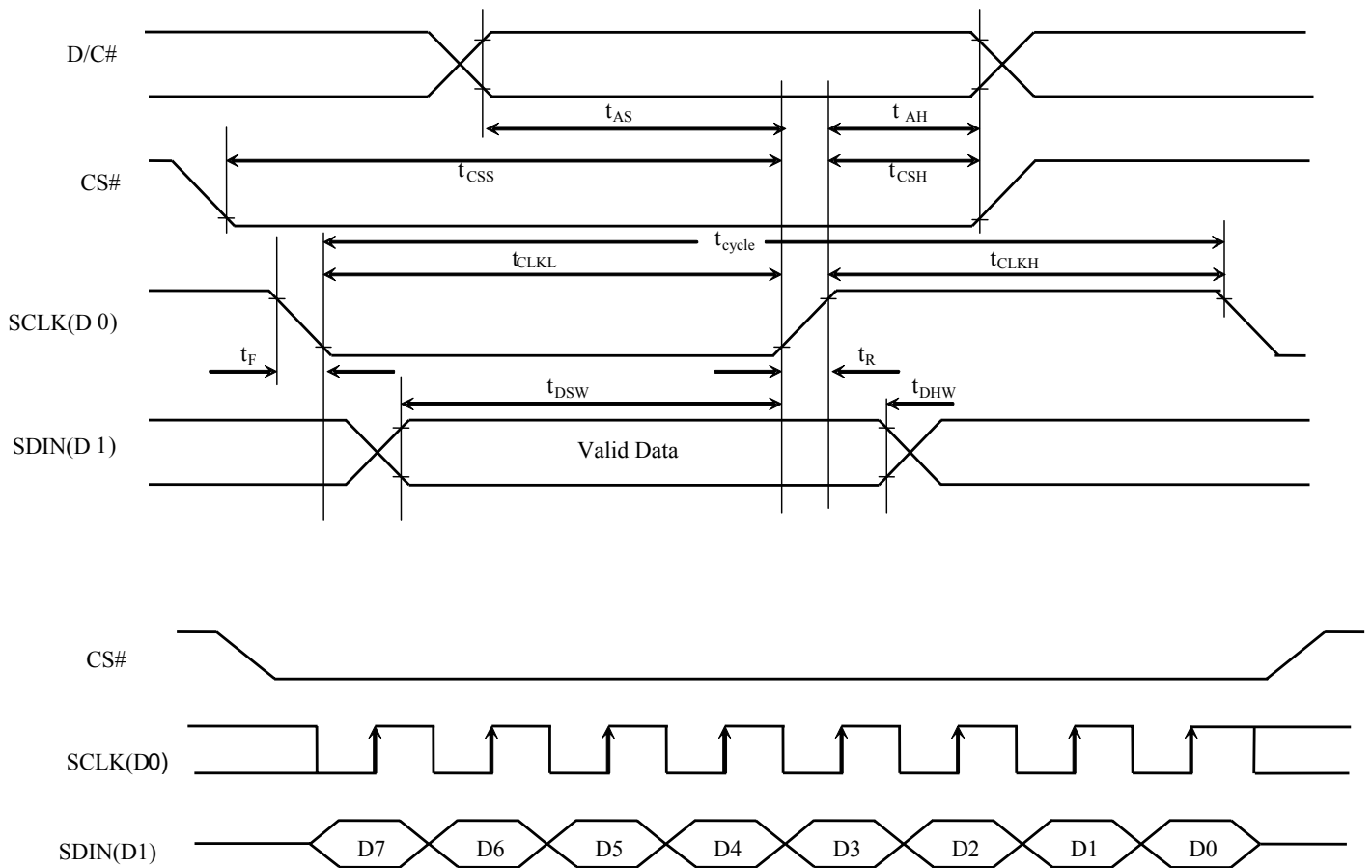

Table 13-4 : Serial Interface Timing Characteristics

($V_{DD} - V_{SS} = 2.4V$ to $3.5V$, $V_{DDIO} = V_{DD}$, $T_A = 25^{\circ}C$)

Symbol	Parameter	Min	Typ	Max	Unit
t_{cycle}	Clock Cycle Time	250	-	-	ns
t_{AS}	Address Setup Time	150	-	-	ns
t_{AH}	Address Hold Time	150	-	-	ns
t_{CSS}	Chip Select Setup Time	120	-	-	ns
t_{CSH}	Chip Select Hold Time	60	-	-	ns
t_{DSW}	Write Data Setup Time	50	-	-	ns </td
t_{DHW}	Write Data Hold Time	15	-	-	ns
t_{CLKL}	Clock Low Time	100	-	-	ns
t_{CLKH}	Clock High Time	100	-	-	ns
t_R	Rise Time	-	-	40	ns
t_F	Fall Time	-	-	40	ns

Figure 13-4 : Serial interface characteristics



Conditions:

$$V_{DD} - V_{SS} = 2.4 \text{ to } 3.5\text{V}$$

$$V_{DDIO} = V_{DD}$$

$$T_A = 25^\circ\text{C}$$

Table 13-5 :I²C Interface Timing Characteristics

Symbol	Parameter	Min	Typ	Max	Unit
t _{cycle}	Clock Cycle Time	2.5	-	-	us
t _{HSTART}	Start condition Hold Time	0.6	-	-	us
t _{HD}	Data Hold Time (for “SDA _{OUT} ” pin)	0	-	-	ns
	Data Hold Time (for “SDA _{IN} ” pin)	300	-	-	ns
t _{SD}	Data Setup Time	100	-	-	ns
t _{SSTART}	Start condition Setup Time (Only relevant for a repeated Start condition)	0.6	-	-	us
t _{SSTOP}	Stop condition Setup Time	0.6	-	-	us
t _R	Rise Time for data and clock pin	-	-	300	ns
t _F	Fall Time for data and clock pin	-	-	300	ns
t _{IDLE}	Idle Time before a new transmission can start	1.3	-	-	us

Figure 13-5 : I²C interface Timing characteristics

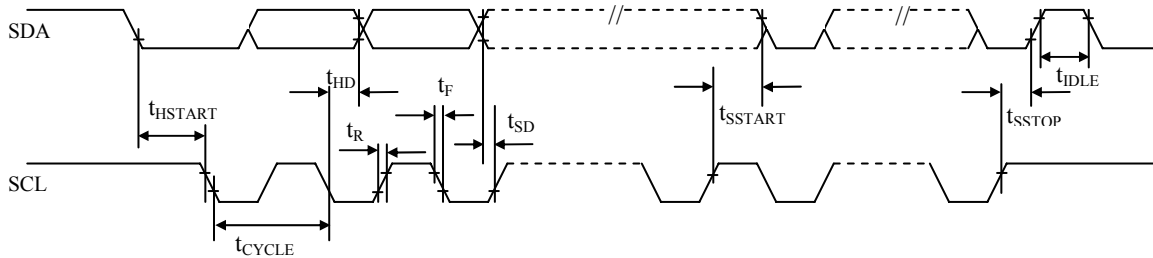

14 APPLICATION EXAMPLE

Figure 14-1 : Application Example of SSD1305T6R1

The configuration for 6800-parallel interface mode, external V_{CC} is shown in the following diagram:
 ($V_{DD}=2.7V$, $V_{CC}=12V$, $I_{REF}=10\mu A$)

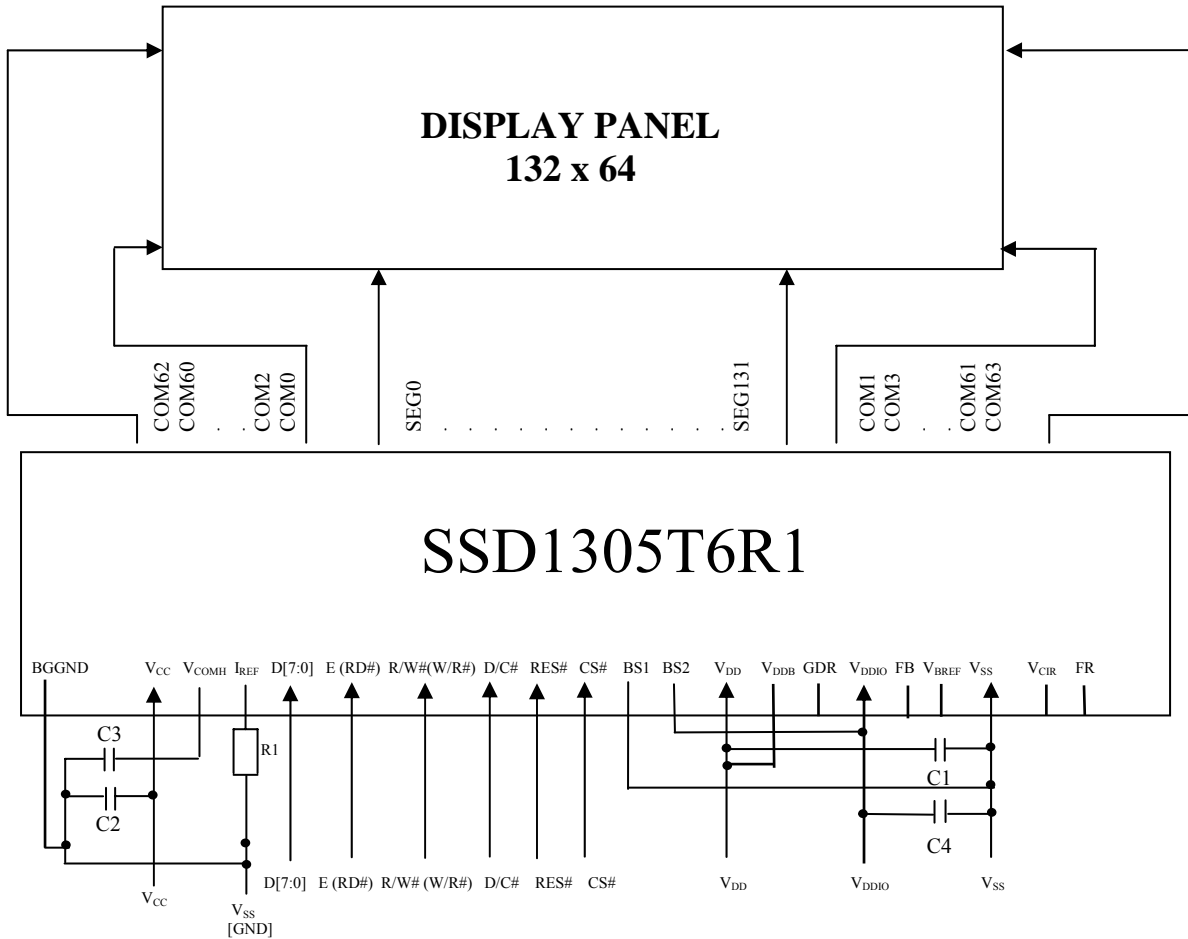

Pin connected to MCU interface: D[7:0], E, R/W#, D/C#, CS#, RES#
 Pin internally connected to V_{SS} : BS0, V_{SSB}
 GDR, V_{BREF} , FB should be left open.

- C1: 4.7 μ F ⁽¹⁾
- C2: 4.7 μ F ⁽¹⁾
- C3: 4.7 μ F ⁽¹⁾
- C4: 4.7 μ F ⁽¹⁾

R1: 910k Ω , $R1 = (\text{Voltage at } I_{REF} \text{ pin} - V_{SS}) / I_{REF}$
 Voltage at I_{REF} pin = $V_{CC} - 3V$

Note

⁽¹⁾ The capacitor value is recommended value. Select appropriate value against module application.

15 PACKAGE INFORMATION

15.1 SSD1305Z Die Tray Information

Figure 15-1 SSD1305Z die tray information

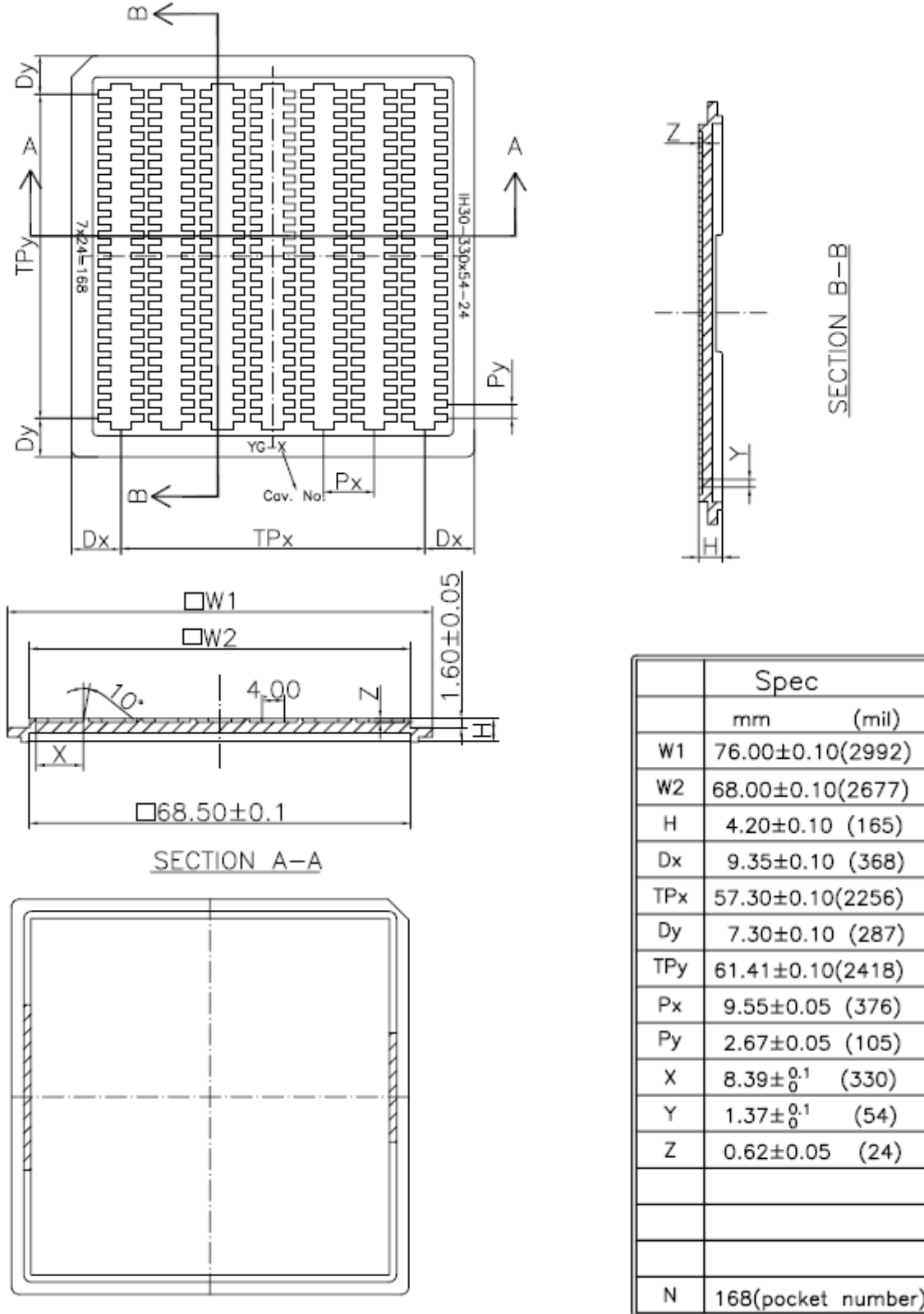

15.2 SSD1305T6R1 Detail Dimension

Figure 15-2 SSD1305T6R1 Detail Dimension

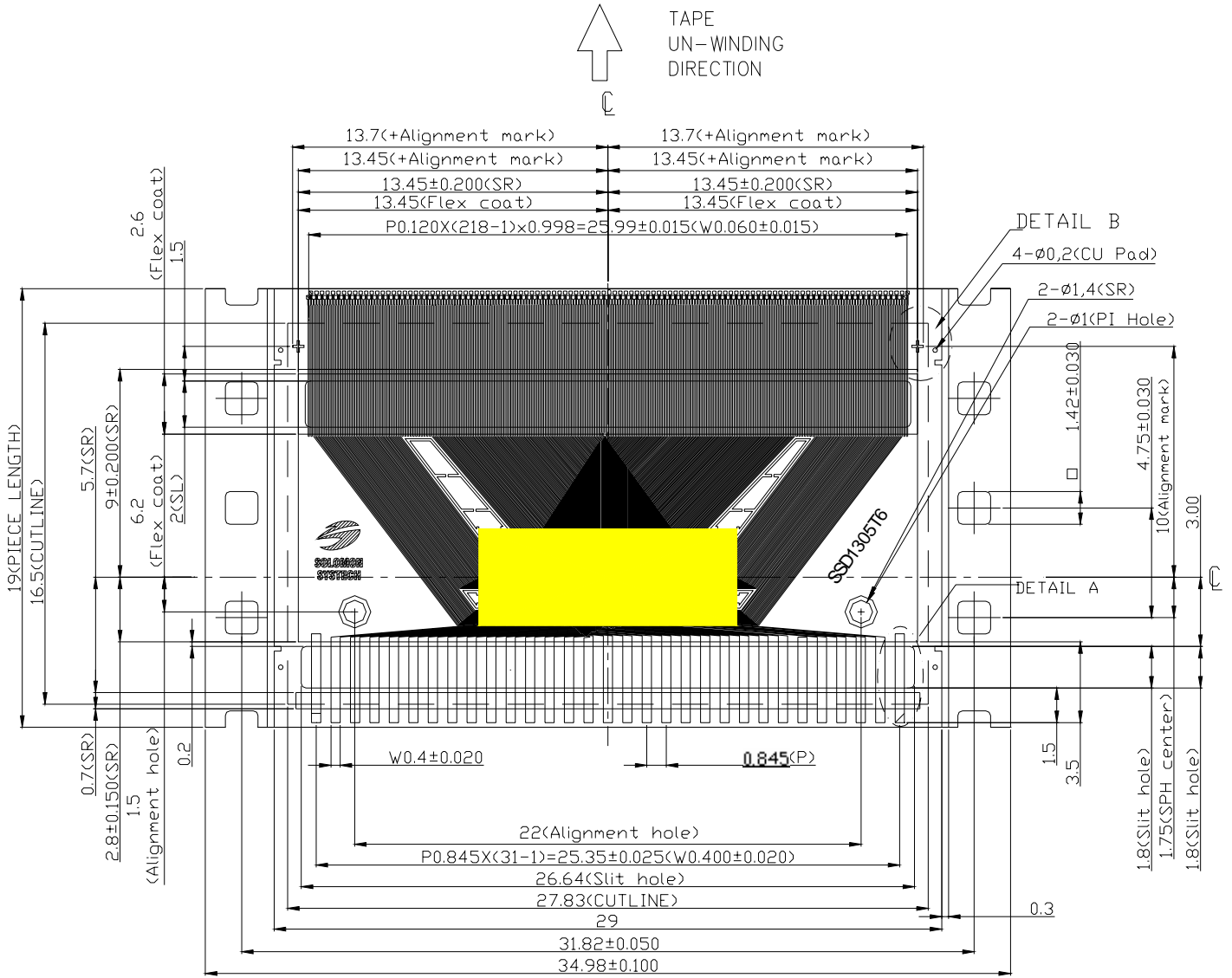

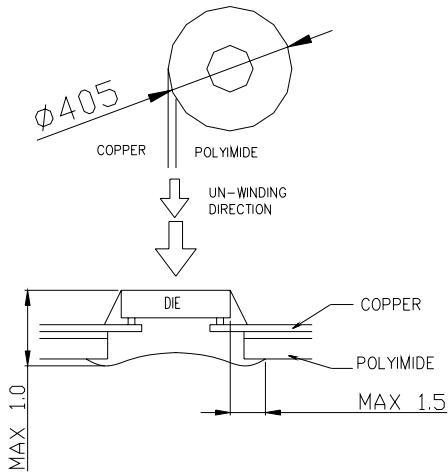

MIRROR DESIGN

NOTE:

1. GENERAL TOLERANCE: $\pm 0.05\text{MM}$
2. MATERIAL
 - PI: $75\pm 6\mu\text{m}$
 - Adhesive: $12\pm 2\mu\text{m}$ thickness
 - CU: $18\pm 5\mu\text{m}$
 - SR: $26\pm 14\mu\text{m}$
 - TOLERANCE ± 0.200
 - Flex coating :Min $10\mu\text{m}$
 - TOLERANCE ± 0.300
3. SN PLATING: $0.200\pm 0.05\mu\text{m}$
4. TAPESITE: 4 SPH, 19mm

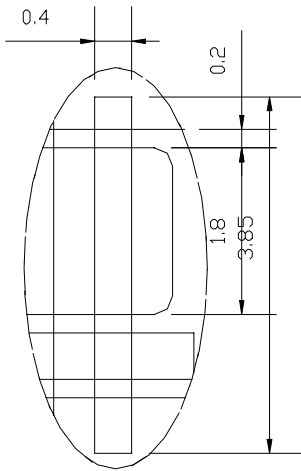

DETAIL A

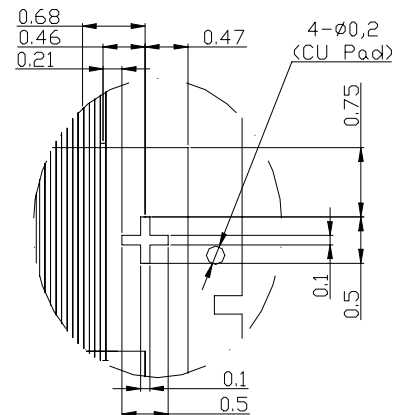

DETAIL B

15.3 SSD1305T7R1 Detail Dimension

Figure 15-3 SSD1305T7R1 Detail Dimension

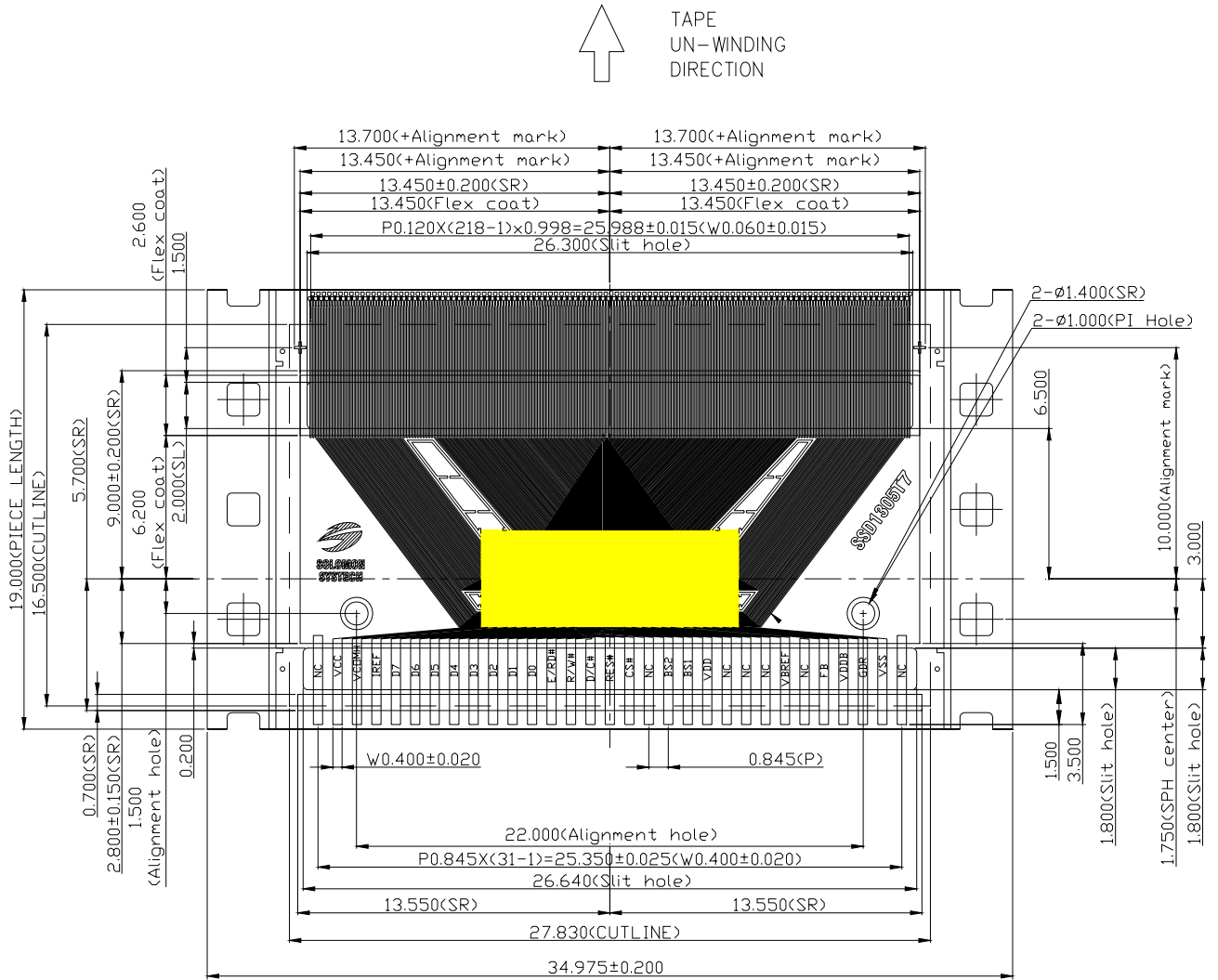

- NOTE:
1. GENERAL TOLERANCE: ±0.05MM
 2. MATERIAL
 - PI: 75±6um
 - Adhesive: 12±2um
 - CU: 18±5um
 - SR: 26±14um
 - TOLERANCE±200um
 - FC: Min 10um
 3. SN PLATING: 0.200±0.05um
 4. TAPESITE: 4 SPH,19mm

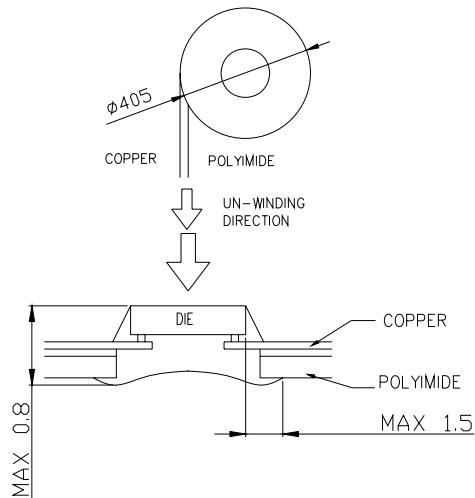

MIRROR DESIGN

15.4 SSD1305Z3 Die Tray Information

Figure 15-4 SSD1305Z3 die tray information

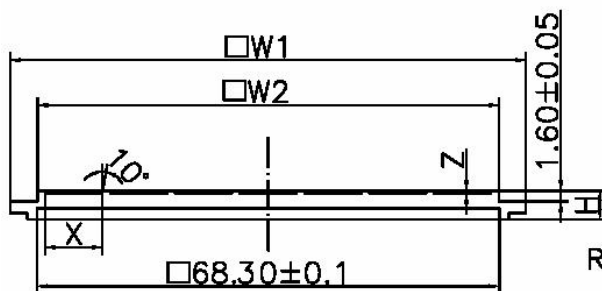
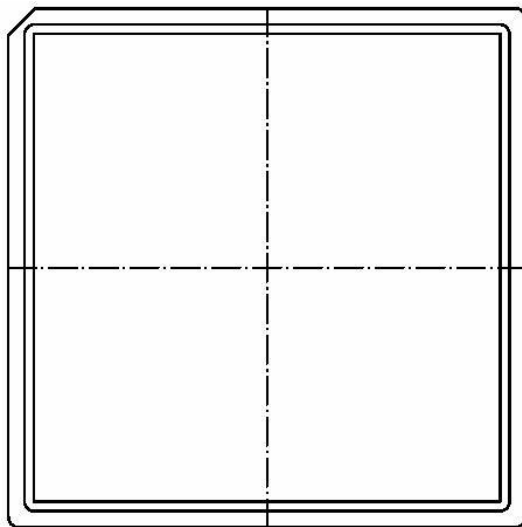
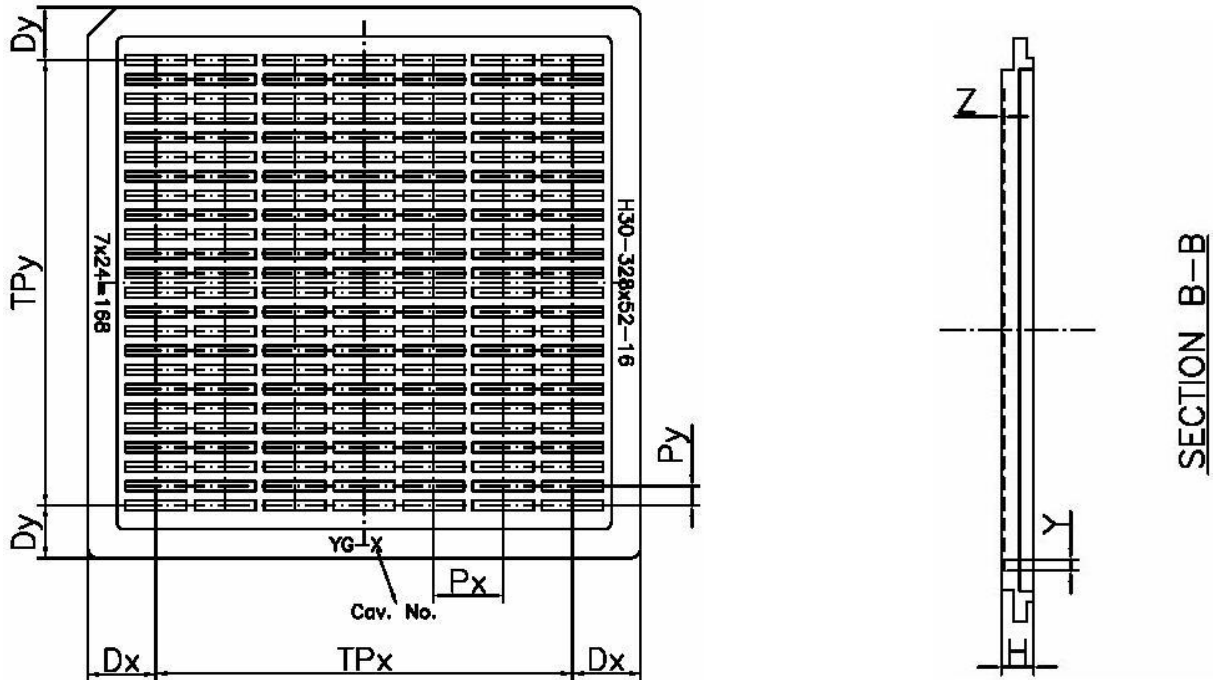

SECTION A-A

	Spec	
	mm	(mil)
W1	76.00±0.10	(2992)
W2	68.00±0.10	(2677)
H	4.20±0.10	(165)
Dx	9.35±0.10	(368)
TPx	57.30±0.10	(2256)
Dy	7.30±0.10	(287)
TPy	61.41±0.10	(2418)
Px	9.55±0.05	(376)
Py	2.67±0.05	(105)
X	8.34±0.05	(328)
Y	1.32±0.05	(52)
Z	0.40±0.05	(16)
N	168(pocket number)	

Remark:

1. Tray Material : ABS
2. Tray Color Code: Black
3. Surface Resistance: $10^9 \sim 10^{12} \Omega/\text{cm}$
4. Pocket Bottom: Rough Surface

Solomon Systech reserves the right to make changes without notice to any products herein. Solomon Systech makes no warranty, representation or guarantee regarding the suitability of its products for any particular purpose, nor does Solomon Systech assume any liability arising out of the application or use of any product or circuit, and specifically disclaims any, and all, liability, including without limitation consequential or incidental damages. “Typical” parameters can and do vary in different applications. All operating parameters, including “Typical” must be validated for each customer application by the customer’s technical experts. Solomon Systech does not convey any license under its patent rights nor the rights of others. Solomon Systech products are not designed, intended, or authorized for use as components in systems intended for surgical implant into the body, or other applications intended to support or sustain life, or for any other application in which the failure of the Solomon Systech product could create a situation where personal injury or death may occur. Should Buyer purchase or use Solomon Systech products for any such unintended or unauthorized application, Buyer shall indemnify and hold Solomon Systech and its offices, employees, subsidiaries, affiliates, and distributors harmless against all claims, costs, damages, and expenses, and reasonable attorney fees arising out of, directly or indirectly, any claim of personal injury or death associated with such unintended or unauthorized use, even if such claim alleges that Solomon Systech was negligent regarding the design or manufacture of the part.

All Solomon Systech Products complied with six (6) hazardous substances limitation requirement per European Union (EU) “Restriction of Hazardous Substance (RoHS) Directive (2002/95/EC)” and China standard “电子信息产品污染控制标识要求 (SJ/T11364-2006)” with control Marking Symbol . Hazardous Substances test report is available upon requested.

<http://www.solomon-systech.com>