



Crystalfontz America, Incorporated

GRAPHIC OLED MODULE SPECIFICATIONS



Shown actual size.

Crystalfontz Model Number	CFAL12864Z-Y-B4
Hardware Version	Revision 1.1, March 2009
Data Sheet Version	Revision 1.0, May 2009
Product Pages	www.crystalfontz.com/product/CFAL12864Z-Y-B4.html

Crystalfontz America, Incorporated

12412 East Saltese Avenue
Spokane Valley, WA 99216-0357

Phone: 888-206-9720

Fax: 509-892-1203

Email: techinfo@crystalfontz.com

URL: www.crystalfontz.com



REVISION HISTORY

HARDWARE	
2009/02/23	Current hardware version: v1.1 New module.

DATA SHEET	
2009/05/20	<p>Current Data Sheet version: v1.0 Since last revision (Preliminary):</p> <ul style="list-style-type: none">● Moved specifications into standard Graphic OLED template.● Added Ordering Information (Pg. 6).● Corrected General Specifications module dimension depth from "9.0 (MAX)" to "9.1 (D) mm". Corrected Contour Drawing module dimension depth from "9.5" to "9.1 Maximum". See Physical Characteristics (Pg. 7) and Module Outline Drawings (Pg. 8).● Corrected "0" minimum for Driver Supply Voltage in Absolute Maximum Ratings (Pg. 11) to "+8v".● Clarified and expanded electrical characteristics (see DC Characteristics (3.3v Operation) (Pg. 12).)● Added illustration to explain Power Up and Power Down Sequencing (Pg. 10).● Added photos with pins labeled. See Quick Reference For Pin Functions (Back/Front Photos) (Pg. 15).● Added explanation of Module Longevity (EOL/Replacement Policy) (Pg. 17).● Improved illustrations, including Module Outline Drawings (Pg. 8) and System Block Diagram (Pg. 10).● Deleted information that is repeated in the controller specifications.● Added appendixes APPENDIX A: QUALITY ASSURANCE STANDARDS (Pg. 20), APPENDIX B: SAMPLE CODE (Pg. 23), APPENDIX C: OLED MODULE TERMS AND SYMBOLS (Pg. 27) and APPENDIX D: SOLOMON SYSTECH SSD1325 CONTROLLER SPECIFICATION SHEET (Pg. 31).
2009/02/23	Data Sheet version: Preliminary New Data Sheet.



The Fine Print

Certain applications using CrystalFontz America, Inc. products may involve potential risks of death, personal injury, or severe property or environmental damage ("Critical Applications"). CRYSTALFONTZ AMERICA, INC. PRODUCTS ARE NOT DESIGNED, INTENDED, AUTHORIZED, OR WARRANTED TO BE SUITABLE FOR USE IN LIFE-SUPPORT APPLICATIONS, DEVICES OR SYSTEMS OR OTHER CRITICAL APPLICATIONS. Inclusion of CrystalFontz America, Inc. products in such applications is understood to be fully at the risk of the customer. In order to minimize risks associated with customer applications, adequate design and operating safeguards should be provided by the customer to minimize inherent or procedural hazard. Please contact us if you have any questions concerning potential risk applications.

CrystalFontz America, Inc. assumes no liability for applications assistance, customer product design, software performance, or infringements of patents or services described herein. Nor does CrystalFontz America, Inc. warrant or represent that any license, either express or implied, is granted under any patent right, copyright, or other intellectual property right of CrystalFontz America, Inc. covering or relating to any combination, machine, or process in which our products or services might be or are used.

The information in this publication is deemed accurate but is not guaranteed.

Company and product names mentioned in this publication are trademarks or registered trademarks of their respective owners.

Copyright © 2009 by CrystalFontz America, Inc., 12412 East Saltese Avenue, Spokane Valley, WA 99216-0357 U.S.A.



CONTENTS

MAIN FEATURES	5
Comparison to LCD Display Module	5
Features	5
Module Classification Information	6
Ordering Information	6
MECHANICAL SPECIFICATIONS	7
Physical Characteristics	7
Module Outline Drawings	8
ELECTRICAL SPECIFICATIONS	10
System Block Diagram	10
Power Up and Power Down Sequencing	10
Absolute Maximum Ratings	11
DC Characteristics (3.3v Operation)	12
Details of Interface Pin Function	13
Quick Reference For Pin Functions (Back/Front Photos)	15
ESD (Electro-Static Discharge)	16
OPTICAL SPECIFICATIONS	16
Optical Characteristics	16
OLED CONTROLLER INTERFACE	17
MODULE RELIABILITY AND LONGEVITY	17
Module Reliability	17
Module Longevity (EOL/Replacement Policy)	17
CARE AND HANDLING PRECAUTIONS	18
APPENDIX A: QUALITY ASSURANCE STANDARDS	20
APPENDIX B: SAMPLE CODE	23
Source For Driver Libraries	23
Sample Code	23
APPENDIX C: OLED MODULE TERMS AND SYMBOLS	27
APPENDIX D: SOLOMON SYSTECH SSD1325 CONTROLLER SPECIFICATION SHEET	31

LIST OF FIGURES

Figure 1. Module Outline Drawings (2 pages)	8
Figure 2. System Block Diagram	10
Figure 3. Power Up and Power Down Sequencing	10
Figure 4. Back View of PCB (Pins Labeled)	15
Figure 5. Front View of PCB (Pins Labeled)	15
Figure 6. CFAL12864Z-Y-B4 has a 160° Viewing Angle	17



MAIN FEATURES

COMPARISON TO LCD DISPLAY MODULE

The CFAL12864Z-Y-B4 is a monochrome 128 x 64 dot matrix Organic Light-Emitting Diode (OLED) display module. The light weight, small size, and ultrathin form factor allows you to use this OLED module in applications where it would be difficult or impossible to fit a traditional STN LCD. The low power requirements make it possible for the CFAL12864Z-Y-B4 to be used in battery powered portable devices such as remote controls and scientific meters (for example, temperature, sound, and gas detection).

Compared to most LCD modules, this OLED module has a quicker response time and an extremely wide viewing angle. At the low end of an STN LCD's temperature range, an LCD module's contrast will typically be poor and the response time will be very slow. The contrast and response time of the CFAL12864Z-Y-B4 OLED module will remain essentially constant through the operating range, allowing it to operate in cold environments without the need for a heater.

FEATURES

- 128 wide x 64 high OLED 93.0 (W) x 70.0 (H) x 9.10 (D) millimeters (3.66" (W) x 2.76" (H) x .36" (D)).
- 8-bit parallel (8080 or 6800) interface or Serial Peripheral Interface (SPI).
- The module displays data directly from its internal 128x 80 x 4 bits Graphic Display Data RAM (GDDRAM). Data / Commands are sent from the host through the hardware selectable 6800 / 8080 series compatible parallel Interface or SPI.
- Built-in Solomon Systech [SSD1325](#) Controller.
- Emissive display: display yellow pixels on dark area or dark pixels on yellow area (if operating with display pixels reversed/inverted).
- Viewing Angle is >160°.
- Wide temperature operation: -20°C to +70°C.
- RoHS compliant.







MODULE CLASSIFICATION INFORMATION

CFA L 128 64 Z - Y - B4 *
 ① ② ③ ④ ⑤ ⑥ ⑦ ⑧

①	Brand	CrystalFontz America, Inc.
②	Display Type	L – OLED
③	Number of Pixels (Width)	128 pixels
④	Number of Pixels (Height)	64 pixels
⑤	Model Identifier	Z
⑥	Display Color	Y – Yellow
⑦	Special Codes 1	B4 – Manufacturer’s codes
⑧	Special Codes 2	* – May have additional manufacturer's codes at this location

ORDERING INFORMATION

PART NUMBER	COLOR	OLED
CFAL12864Z-Y-B4	yellow	
<i>Additional modules in this series.</i>		
CFAL12864Z-G-B4	green	
CFAL12864Z-G-B2	green	
CFAL12864Z-Y-B2	yellow	



MECHANICAL SPECIFICATIONS

PHYSICAL CHARACTERISTICS

ITEM	SIZE
Number of Pixels	128 x 64 pixels = 8,192 pixels
Dimensions	93.0 (W) x 70.0 (H) x 9.1 (D) mm
Viewing Area	65.0 (W) x 33.0 (H) mm
Active Area	61.41 (W) x 30.69 (H) mm
Pixel Size	0.45 (W) x 0.45 (H) mm
Pixel Pitch	0.48 (W) x 0.48 (H) mm
Aperture Rate*	67.2%
Weight	49 grams (typical)
<i>*Aperture rate is defined by dividing an effective display area with unit pixel area.</i>	



MODULE OUTLINE DRAWINGS

Figure 1. Module Outline Drawings (2 pages)

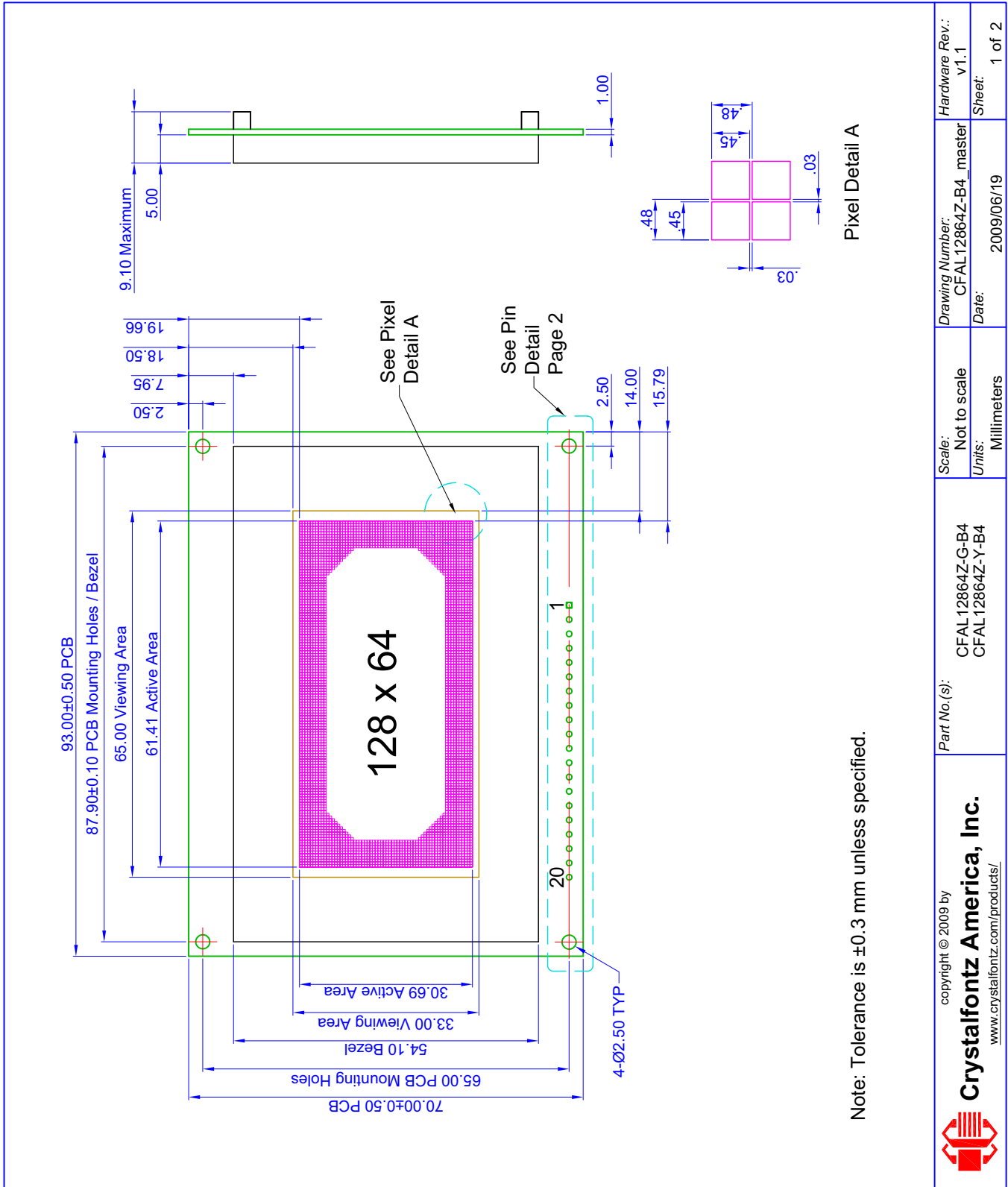

 copyright © 2009 by CrystalFontz America, Inc. www.crystalfontz.com/products/	Part No.(s): CFAL12864Z-G-B4 CFAL12864Z-Y-B4	Scale: Not to scale Units: Millimeters	Drawing Number: CFAL12864Z-B4_master Date: 2009/06/19 Hardware Rev.: V1.1 Sheet: 1 of 2
---	--	---	--

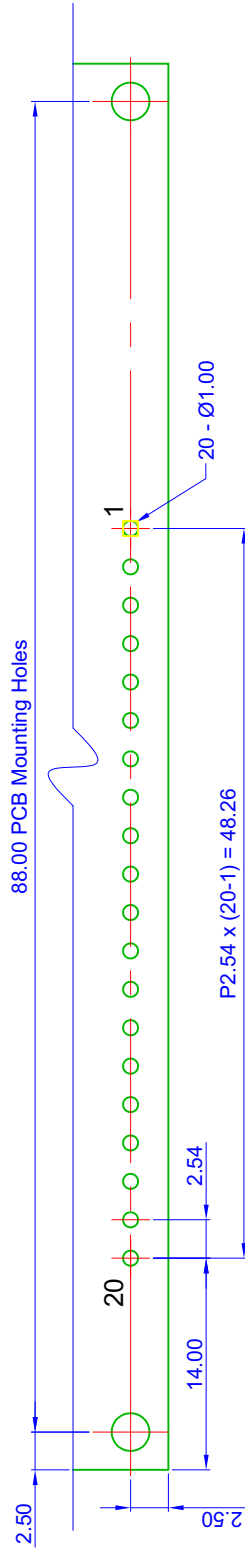

Pin Detail

Note: Tolerance is ± 0.3 mm unless specified.

 copyright © 2009 by CrystalFontz America, Inc. www.crystalfontz.com/products/	Part No.(s): CFAL12864Z-G-B4 CFAL12864Z-Y-B4	Scale: Not to scale Units: Millimeters	Drawing Number: CFAL12864Z-B4_master Date: 2009/06/19	Hardware Rev.: v1.1 Sheet: 2 of 2
---	--	---	--	--



ELECTRICAL SPECIFICATIONS

SYSTEM BLOCK DIAGRAM

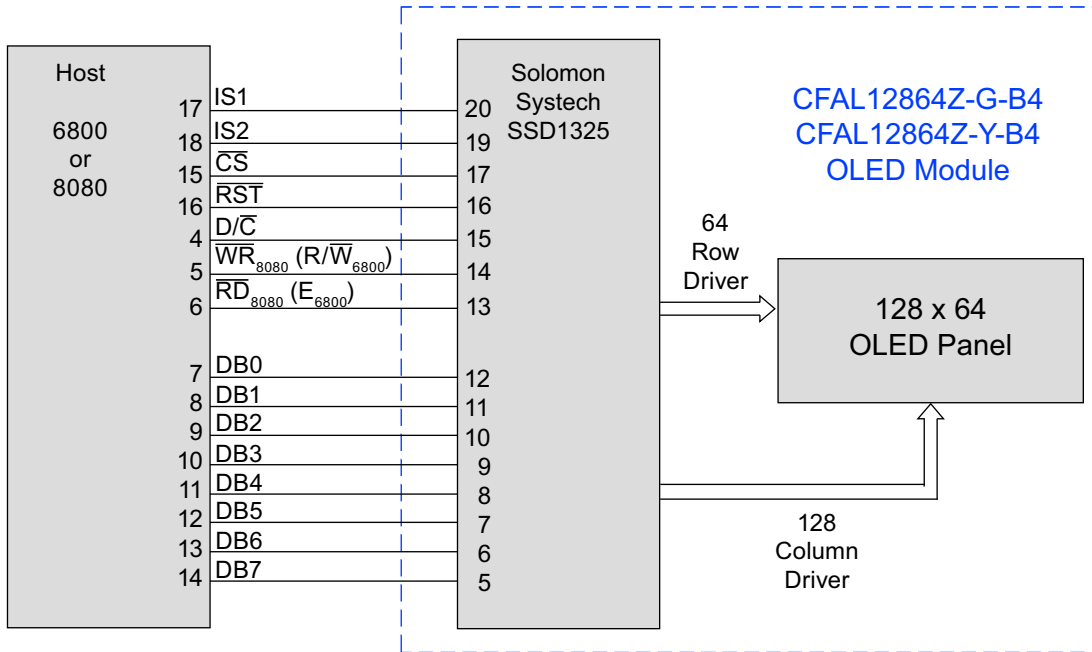

Figure 2. System Block Diagram

POWER UP AND POWER DOWN SEQUENCING

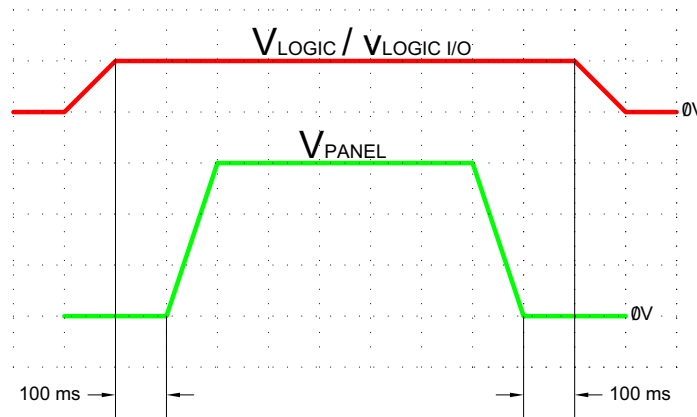

Figure 3. Power Up and Power Down Sequencing



ABSOLUTE MAXIMUM RATINGS

ABSOLUTE MAXIMUM RATINGS	SYMBOL	MINIMUM	MAXIMUM
Operating Temperature*	T _{OP}	-20°C	+70°C
Storage Temperature*	T _{ST}	-30°C	+80°C
Logic Supply Voltage	V _{LOGIC}	+2.4v	+3.5v
Driver Supply Voltage	V _{PANEL}	+8v	+16v
<i>*Prolonged exposure at temperatures outside of this range may cause permanent damage to the module.</i>			



DC CHARACTERISTICS (3.3V OPERATION)

DC CHARACTERISTICS	TEST CONDITION	SYMBOL	MINIMUM	TYPICAL	MAXIMUM
Logic Supply Voltage	$T_{OP} = -30^{\circ}C$ to $+70^{\circ}C$	V_{LOGIC}	+2.4v	+3.3v	+3.5v¹
OLED Driver Supply Voltage ²	$T_{OP} = -30^{\circ}C$ to $+70^{\circ}C$	V_{PANEL}	+8v	+12v	+16v
Input High Voltage		V_{IH}	$+0.8v \times V_{Logic}$ For $V_{Logic} = +3.3v$ $V_{IH} = +0.8v \times +3.3v$ $= +2.64v$		V_{Logic}
Input Low Voltage		V_{IL}	0v (GND)		$+0.2v \times V_{Logic}$ For $V_{Logic} = +3.3v$ $V_{IL} = +0.2v \times +3.3v =$ $+0.66v$
Output High Voltage	$I_{OUT} = 100\mu A$ 3.3MHz	V_{OH}	$+0.9v \times V_{Logic}$ For $V_{Logic} = +3.3v$ $V_{OH} = +0.9v \times +3.3v$ $= +2.97v$		V_{Logic}
Output Low Voltage	$I_{OUT} = 100\mu A$ 3.3MHz	V_{OL}	0v (GND)		$+0.1v \times V_{Logic}$ For $V_{Logic} = +3.3v$ $V_{OL} = +0.1v \times +3.3v =$ $+0.33v$

¹**Do not exceed +3.5v absolute maximum.**

²The V_{PANEL} input must be a stable value with no ripple or noise.

This is a summary of the module's major operating parameters. For detailed information see [APPENDIX D: SOLOMON SYSTECH SSD1325 CONTROLLER SPECIFICATION SHEET \(Pg. 31\)](#).



DETAILS OF INTERFACE PIN FUNCTION

PIN	SIGNAL	LEVEL	DIRECTION	DESCRIPTION
1	GND	0v		Ground. Must be connected to an external ground.
2	V _{LOGIC}			Power supply input. Must be connected to an external source.
3	NC			No Connection.
4	D/C	H/L	I	Data/Command control. Determines whether data bits are data or command. <i>1 – High: Addresses the data register.</i> <i>0 – Low: Addresses the command register.</i>
5	\overline{WR}_{8080} (R/ \overline{W}_{6800})	H/L	I	Host interface input. <i>8080 Host: Active low. Signal on the databus is latched at the rising edge of \overline{WR} signal.</i> <i>6800 Host: Read/Write control signal output.</i> <i>R/\overline{W} = High: Read (Host←Module)</i> <i>R/\overline{W} = Low: Write (Host→Module)</i>
6	\overline{RD}_{8080} (E ₆₈₀₀)	H/L	I	Host interface input. <i>8080 Host: Active low. Signal on the databus is latched at the rising edge of \overline{RD}.</i> <i>6800 Host: Enable control signal input active high.</i> <i>E = High: Read or Write operation is active</i> <i>E = Low: No operation</i>
7	DB0	H/L	I/O	Bidirectional databus connects to 8-bit or 16-bit standard host databus. <i>In serial mode (IS1=0, IS2=0):</i> DB0 serves as the serial clock input signal (SCL) and DB1 serves as the serial data input pin (SI). DB2-DB7 are high impedance. In serial mode, data can be written to the display but not read. Pin 5 (\overline{WR}_{8080} (R/ \overline{W}_{6800}) and pin 6 (\overline{RD}_{8080} (E ₆₈₀₀)) are unused and should be tied low. <i>In 6800 Parallel mode:</i> Pin 5 is used as R/ \overline{W}_{6800} . Pin 6 is used as E ₆₈₀₀ . Data is input or output on DB0-DB7. <i>In 8080 Parallel mode:</i> Pin 5 is used as \overline{WR}_{8080} . Pin 6 is used as \overline{RD}_{8080} . Data is input or output on DB0-DB7.
8	DB1	H/L	I/O	
9	DB2	H/L	I/O	
10	DB3	H/L	I/O	
11	DB4	H/L	I/O	
12	DB5	H/L	I/O	
13	DB6	H/L	I/O	
14	DB7	H/L	I/O	
15	\overline{CS}	H/L	I	Chip select input. <i>Low: Controller chip is selected. Communications with host is possible.</i> <i>High: Controller chip is not selected. Host interface signals are ignored by the controller.</i>
16	\overline{RST}	L	I	Reset signal input <i>Low: Display controller is reset. The \overline{RST} pin should be pulsed low shortly after power is applied.</i> <i>High: The RST pin should be brought high for normal operation.</i>



PIN	SIGNAL	LEVEL	DIRECTION	DESCRIPTION															
17	IS1	H/L	I	<table border="1"> <thead> <tr> <th>IS1</th> <th>IS2</th> <th>Interface Mode</th> </tr> </thead> <tbody> <tr> <td>0</td> <td>0</td> <td>Serial</td> </tr> <tr> <td>0</td> <td>1</td> <td>00 Parallel</td> </tr> <tr> <td>1</td> <td>0</td> <td>Not Allowed</td> </tr> <tr> <td>1</td> <td>1</td> <td>8080 Parallel</td> </tr> </tbody> </table>	IS1	IS2	Interface Mode	0	0	Serial	0	1	00 Parallel	1	0	Not Allowed	1	1	8080 Parallel
IS1	IS2	Interface Mode																	
0	0	Serial																	
0	1	00 Parallel																	
1	0	Not Allowed																	
1	1	8080 Parallel																	
18	IS2	H/L	I																
19	NC		I	No Connection.															
20	FG			Frame ground.															



QUICK REFERENCE FOR PIN FUNCTIONS (BACK/FRONT PHOTOS)

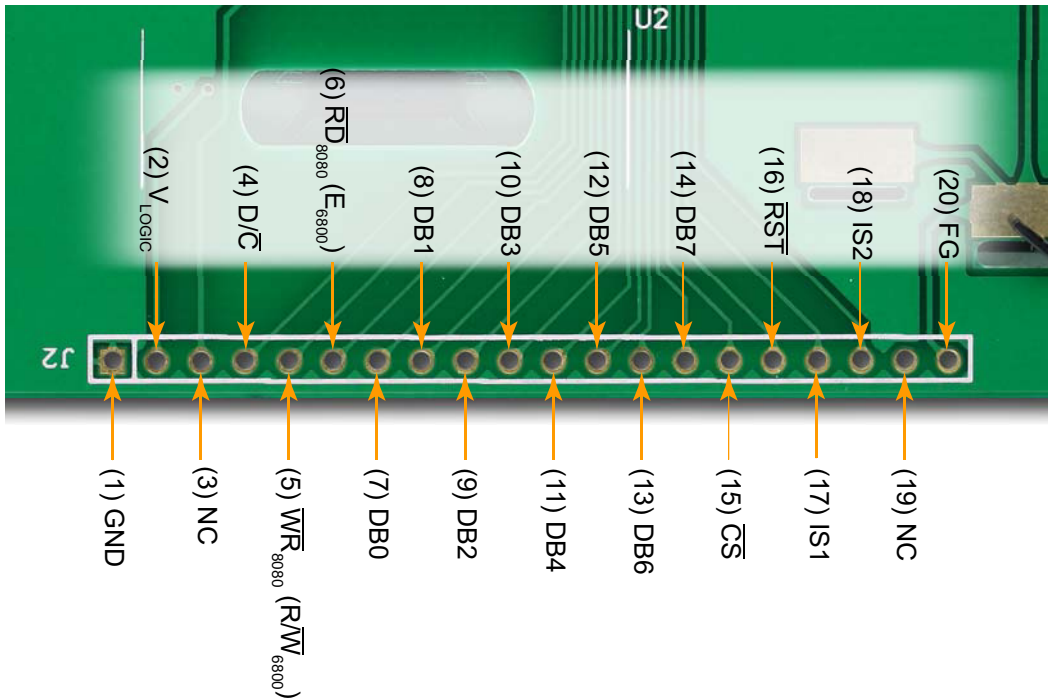

Figure 4. Back View of PCB (Pins Labeled)

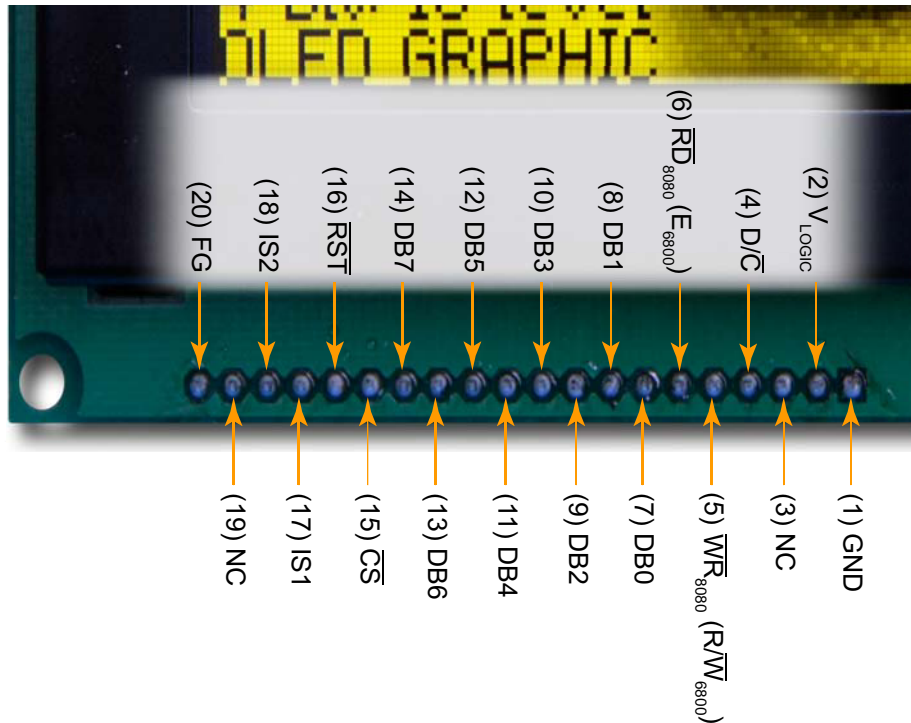

Figure 5. Front View of PCB (Pins Labeled)



ESD (ELECTRO-STATIC DISCHARGE)

The circuitry is industry standard CMOS logic and susceptible to ESD damage. Please use industry standard antistatic precautions as you would for any other PCB such as expansion cards or motherboards. Ground your body, work surfaces, and equipment.

OPTICAL SPECIFICATIONS

OPTICAL CHARACTERISTICS

ITEM	SYMBOL	TEST CONDITION	TYPICAL
Viewing Angle			>160°
Dark Room Contrast Ratio ¹	CR	80 cd/m ²	>100:1
Response Time ²			<1 ms
Luminous Intensity (IV)	L _{BR}	with polarizer	80 cd/m ²
Duty		1/64	
<i>¹Contrast Ratio = (brightness with pixels light)/(brightness with pixels dark). ²Response Time: The amount of time it takes a pixel to change from active to inactive or back again.</i>			



Definition of Viewing Angle

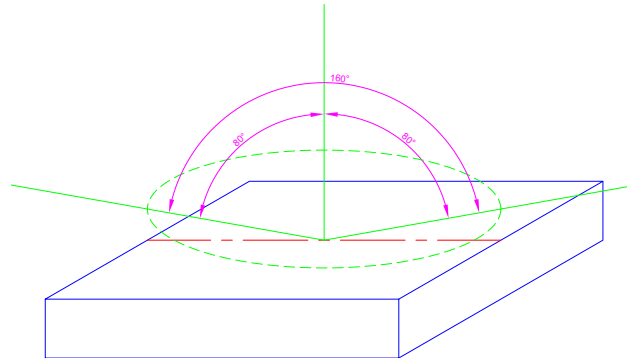

Figure 6. CFAL12864Z-Y-B4 has a 160° Viewing Angle

OLED CONTROLLER INTERFACE

This module uses a Solomon Systech SSD1325 controller. For your reference, we added [APPENDIX D: SOLOMON SYSTECH SSD1325 CONTROLLER SPECIFICATION SHEET \(Pg. 31\)](#) to this Data Sheet.

MODULE RELIABILITY AND LONGEVITY

MODULE RELIABILITY

AVERAGE BRIGHTNESS	SPECIFICATION
80 cd/m ²	Brightness will be >50% of a new module's initial brightness for at least 10,000 hours of operation.
40 cd/m ²	20,000 hours.
<i>Test Condition: 25°C.</i>	

OLED displays are an emissive technology. Each pixel is susceptible to dimming based on its individual use (burn-in). Frequently used pixels will dim more quickly than pixels that are not used as often. Please avoid using a bright, static, high-contrast image for a long time. If you want to leave the display powered on, please use scrolling text or alternating images to "wear level" the pixels. To conserve power and display lifetime, turn off or dim the display when it is not in use.

MODULE LONGEVITY (EOL/REPLACEMENT POLICY)

Crystalfontz is committed to making all of our modules available for as long as possible. For each module we introduce, we intend to offer it indefinitely. We do not preplan a module's obsolescence. The majority of modules we have introduced are still available.



We recognize that discontinuing a module may cause problems for some customers. However, rapidly changing technologies, component availability, or low customer order levels may force us to discontinue ("End of Life", EOL) a module. For example, we must occasionally discontinue a module when a supplier discontinues a component or a manufacturing process becomes obsolete. When we discontinue a module, we will do our best to find an acceptable replacement module with the same fit, form, and function.

In most situations, you will not notice a difference when comparing a "fit, form, and function" replacement module to the discontinued module. However, sometimes a change in component or process for the replacement module results in a slight variation, perhaps an improvement, over the previous design.

Although the replacement module is still within the stated Data Sheet specifications and tolerances of the discontinued module, changes may require modification to your circuit and/or firmware. Possible changes include:

- *Controller.* A new controller may require minor changes in your code.
- *Component tolerances.* Module components have manufacturing tolerances. In extreme cases, the tolerance stack can change the visual or operating characteristics.

Please understand that we avoid changing a module whenever possible; we only discontinue a module if we have no other option. We will post Part Change Notices on the product's webpage as soon as possible. If interested, you can subscribe to future part change notifications.

CARE AND HANDLING PRECAUTIONS

For optimum operation of the module and to prolong its life, please follow the precautions below.

ESD (ELECTRO-STATIC DISCHARGE)

The circuitry is industry standard CMOS logic and susceptible to ESD damage. Please use industry standard antistatic precautions as you would for any other PCB such as expansion cards or motherboards. Ground your body, work surfaces, and equipment.

DESIGN AND MOUNTING

- The exposed surface of the "glass" is actually a polarizer laminated on top of the glass. To protect the soft plastic polarizer from damage, the module ships with a protective film over the polarizer. Please peel off the protective film slowly. Peeling off the protective film abruptly may generate static electricity.
- The polarizer is made out of soft plastic and is easily scratched or damaged. When handling the module, avoid touching the polarizer. Finger oils are difficult to remove.
- To protect the soft plastic polarizer from damage, place a transparent plate (for example, acrylic, polycarbonate, or glass) in front of the module, leaving a small gap between the plate and the display surface. We use GE HP-92 Lexan, which is readily available and works well.
- Do not disassemble or modify the module.
- Do not modify the tab of the metal holder or make connections to it.
- For prototype work, hand soldering may be acceptable. Preset soldering iron to <math><260^{\circ}\text{C}</math>. Do not apply heat for more than 3 to 4 seconds.
- Do not reverse polarity to the power supply connections. Reversing polarity will immediately ruin the module.
- Use care to keep the exposed terminals clean. Contamination, including fingerprints may make the soldering difficult, and the reliability of the soldered connection poor.



AVOID SHOCK, IMPACT, TORQUE, OR TENSION

- Do not expose the module to strong mechanical shock, impact, torque, or tension.
- Do not drop, toss, bend, or twist the module.
- Do not place weight or pressure on the module.

CLEANING

The polarizer (laminated to the glass) is soft plastic. The soft plastic is easily scratched or damaged. Be very careful when you clean the polarizer.

- Do not clean the polarizer with liquids. Do not wipe the polarizer with any type of cloth or swab (for example, Q-tips).
- Use the removable protective film to remove smudges (for example, fingerprints) and any foreign matter. If you no longer have the protective film, use standard transparent office tape (for example, Scotch® brand "Crystal Clear Tape"). If the polarizer is dusty, you may carefully blow it off with clean, dry, oil-free compressed air.

OPERATION

- We do not recommend connecting this module to a PC's parallel port as an "end product." This module is not "user friendly" and connecting it to a PC's parallel port is often difficult, frustrating, and can result in a "dead" display due to mishandling. For more information, see our forum thread at <http://www.crystalfontz.com/forum/showthread.php?s=&threadid=3257>.
- Your circuit should be designed to protect the module from ESD and power supply transients.
- Observe the operating temperature limitations: from -20°C minimum to +70°C maximum with minimal fluctuations. Operation outside of these limits may shorten the life and/or harm the display.
- Operate away from dust, moisture, and direct sunlight.

STORAGE AND RECYCLING



- Store in an ESD-approved container away from dust, moisture, and direct sunlight, fluorescent lamps, or any ultraviolet ray.
- Observe the storage temperature limitations: from -30°C minimum to +80°C maximum with minimal fluctuations. Rapid temperature changes can cause moisture to form, resulting in permanent damage.
- Do not allow weight to be placed on the modules while they are in storage.
- Please recycle your outdated Crystalfontz modules at an approved facility.



APPENDIX A: QUALITY ASSURANCE STANDARDS

INSPECTION CONDITIONS

- Environment
 - Temperature: 25±5°C
 - Humidity: 30~85% RH (noncondensing)
- For visual inspection of active display area
 - Source lighting: two 20-Watt or one 40-Watt fluorescent light
 - Display adjusted for best contrast
 - Viewing distance: 30±5 cm (about 12 inches)
 - Viewing angle: inspect at 45° angle of vertical line right and left, top and bottom

COLOR DEFINITIONS

We try to describe the appearance of our modules as accurately as possible. For the photos, we adjust for optimal appearance. Actual display appearance may vary due to (1) different operating conditions, (2) small variations of component tolerances, (3) inaccuracies of our camera, (4) color interpretation of the photos on your monitor, and/or (5) personal differences in the perception of color.

DEFINITION OF ACTIVE AREA AND VIEWING AREA

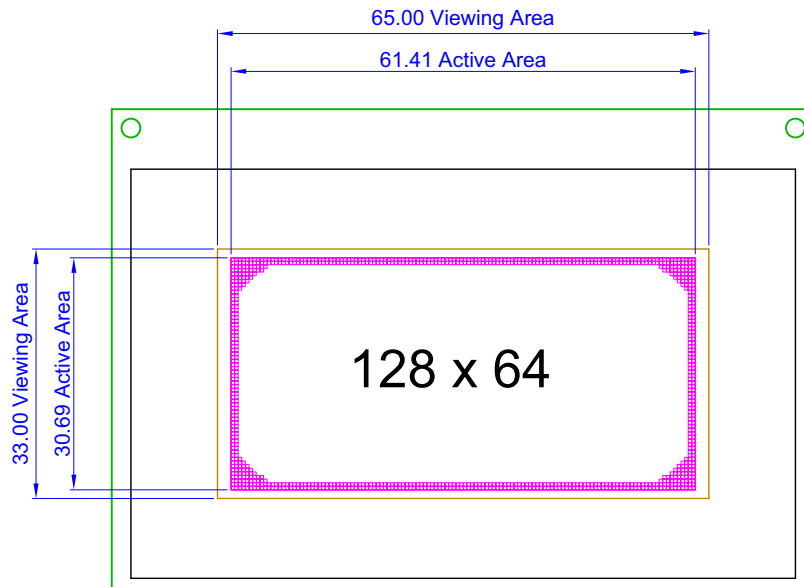



ACCEPTANCE SAMPLING

DEFECT TYPE	AQL*
Major	≤.65%
Minor	<1.0%
* Acceptable Quality Level: maximum allowable error rate or variation from standard	

DEFECTS CLASSIFICATION

Defects are defined as:

- Major Defect: results in failure or substantially reduces usability of unit for its intended purpose
- Minor Defect: deviates from standards but is not likely to reduce usability for its intended purpose

ACCEPTANCE STANDARDS

#	DEFECT TYPE	CRITERIA			MAJOR / MINOR	
1	Electrical defects	1. No display, display malfunctions, or shorted segments. 2. Current consumption exceeds specifications.			Major	
2	Viewing area defect	Viewing area does not meet specifications.			Major	
3	Blemishes or foreign matter on display segments		<i>Defect Size</i>	<i>Acceptable Qty</i>	Minor	
			≤0.30 mm	3		
			≤2 defects within 10 mm of each other			
4	Dark lines or scratches in display area		<i>Defect Width</i>	<i>Defect Length</i>	<i>Acceptable Qty</i>	Minor
			≤0.03 mm	≤3.0 mm	3	
			0.03 to 0.05	≤2.0 mm	2	
			0.05 to 0.08	≤2.0 mm	1	
			0.08 to 0.10	≤3.0 mm	0	
			≥0.10	>3.0 mm	0	



#	DEFECT TYPE	CRITERIA		MAJOR / MINOR
5	Bubbles between polarizer film and glass	<i>Defect Size</i>	<i>Acceptable Qty</i>	Minor
		≤0.20 mm	Ignore	
		0.20 to 0.40 mm	3	
		0.40 to 0.60 mm	2	
		≥0.60 mm	0	
6	Display pattern defect			Minor
		<i>Pixel Size</i>	<i>Acceptable Qty</i>	
		$((A+B)/2) \leq 0.20$ mm	≤ 3 total defects ≤ 2 pinholes per digit	
		$C > 0$ mm		
		$((D+E)/2) \leq 0.25$ mm		
		$((F+G)/2) \leq 0.25$ mm		
7	PCB defects	<ol style="list-style-type: none"> 1. Oxidation or contamination on connectors.* 2. Wrong parts, missing parts, or parts not in specification.* 3. Jumpers set incorrectly. 4. Solder (if any) on bezel, LED pad, zebra pad, or screw hole pad is not smooth. *Minor if display functions correctly. Major if the display fails.		Minor
8	Soldering defects	<ol style="list-style-type: none"> 1. Unmelted solder paste. 2. Cold solder joints, missing solder connections, or oxidation.* 3. Solder bridges causing short circuits.* 4. Residue or solder balls. 5. Solder flux is black or brown. *Minor if display functions correctly. Major if the display fails.		Minor



APPENDIX B: SAMPLE CODE

SOURCE FOR DRIVER LIBRARIES

Graphic driver libraries may save you a lot of time and help you develop a more professional product. Possible library sources are [easyGUI](#), [RAMTEX](#), [Micrium](#), [en.radzio.dxp.pl](#), and [Segger emWin](#).

SAMPLE CODE

This code will initialize the display and show a screen. You can download the complete source from our website. *Note:* Please observe V_{PP} sequencing as described in [Details of Interface Pin Function \(Pg. 12\)](#). See also [Power Up and Power Down Sequencing \(Pg. 9\)](#).

```
.
#include <avr/io.h>
#include <avr/interrupt.h>
#include <util/delay.h>
#include <avr/pgmspace.h>

// all on PORTC
#define LCD_CDPC7
#define LCD_WR PC6
#define LCD_RD PC5
#define LCD_CSPC4
#define LCD_RESPC2

#define CLR_CD PORTC &= ~(1<<LCD_CD);
#define SET_CD PORTC |= (1<<LCD_CD);

#define CLR_CS PORTC &= ~(1<<LCD_CS);
#define SET_CS PORTC |= (1<<LCD_CS);

#define CLR_RESET PORTC &= ~(1<<LCD_RES);
#define SET_RESET PORTC |= (1<<LCD_RES);

// 8080 mode pin functions
#define CLR_WR PORTC &= ~(1 << LCD_WR);
#define SET_WR PORTC |= (1 << LCD_WR);
#define CLR_RD PORTC &= ~(1 << LCD_RD);
#define SET_RD PORTC |= (1 << LCD_RD);

//Bitmap to be displayed on OLED module
unsigned char Data_12864greynocolorsbmp[4096] = {SEE FULL TEXT FROM WEBSITE};

void delay(uint32_t twait)
{
    while (twait--)
        asm volatile ("nop");
}

void WriteCommand(unsigned command)
{
```



```
PORTA = command;// set up data on bus
CLR_CS; // chip selected
CLR_CD; // command mode
SET_RD;

// clock WR
CLR_WR;
SET_WR;

SET_CS; // deselect chip
}

void WriteData(unsigned data)
{
    PORTA = data;// set up data on bus
    SET_CD; // data mode
    CLR_CS; // chip selected
    SET_RD;

    // clock WR
    CLR_WR;
    SET_WR;

    SET_CS; // deselect chip
}

void reset_display(void)
{
    CLR_RESET;
    delay(10000);
    SET_RESET;
}

void init_OLED()
{
    reset_display();

    // Column Address
    WriteCommand(0x15); // Set Column Address
    WriteCommand(0x00); // Start = 0
    WriteCommand(0x3F); // End = 127

    // Row Address
    WriteCommand(0x75); // Set Row Address
    WriteCommand(0x0C); // Start = 0
    WriteCommand(0x4B); // End = 63

    // Contrast Control
    WriteCommand(0x81); // Set Contrast Control
    WriteCommand(0x38); // 0 ~ 127

    // Current Range
    WriteCommand(0x86); // Set Current Range84h:Quarter, 85h:Half,86h:Full

    // Re-map
    WriteCommand(0xA0); // Set Re-map
    WriteCommand(0x52); // [0]:MX, [1]:Nibble, [2]:H/Vaddress [4]:MY, [6]:Com Split Odd/Even "100010"
```



```
// Display Start Line
WriteCommand(0xA1); // Set Display Start Line
WriteCommand(0x0c); // Top

// Display Offset
WriteCommand(0xA2); // Set Display Offset
WriteCommand(0x4C); // No offset

// Display Mode
WriteCommand(0xA4); // Set Display Mode,A4:Normal,A5:All ON, A6: All OFF ,A7:Inverse

// Multiplex Ratio
WriteCommand(0xA8); // Set Multiplex Ratio
WriteCommand(0x3F); // [6:0]16~128, 64 rows=3Fh

// Phase Length
WriteCommand(0xB1); // Set Phase Length
WriteCommand(0x22); // [3:0]:Phase 1 period of 1~16clocks
// [7:4]:Phase 2 period of 1~16clocks // POR = 0111 0100
// Row Period
WriteCommand(0xB2); // Set Row Period
WriteCommand(0x46); // [7:0]:18~255,K=P1+P2+GS15 (POR:4+7+29)

// Display Clock Divide
WriteCommand(0xB3); // Set Clock Divide
WriteCommand(0x41); // [3:0]:1~16, [7:4]:0~16
// POR = 0000 0001
// VSL
WriteCommand(0xBF); // Set VSL
WriteCommand(0x0D); // [3:0]:VSL

// CCOMH
WriteCommand(0xBE); // Set VCOMH
WriteCommand(0x00); // [7:0]:VCOMH

// VP
WriteCommand(0xBC); // Set VP
WriteCommand(0x0B); // [7:0]:VP

// Gamma
WriteCommand(0xB8); // Set Gamma with next 8 bytes
WriteCommand(0x01); // L1[2:1]
WriteCommand(0x11); // L3[6:4], L2[2:0] 0001 0001
WriteCommand(0x22); // L5[6:4], L4[2:0] 0010 0010
WriteCommand(0x32); // L7[6:4], L6[2:0] 0011 1011
WriteCommand(0x43); // L9[6:4], L8[2:0] 0100 0100
WriteCommand(0x54); // LB[6:4], LA[2:0] 0101 0101
WriteCommand(0x65); // LD[6:4], LC[2:0] 0110 0110
WriteCommand(0x76); // LF[6:4], LE[2:0] 1000 0111

// Set DC-DC
WriteCommand(0xAD); // Set DC-DC OFF
WriteCommand(0x02);

// Display ON/OFF
WriteCommand(0xAF); // AF=ON, AE=Sleep Mode
```



```
}  
  
void show_bitmap()  
{  
    unsigned char j=0;  
    unsigned char i=0;  
  
    WriteCommand(0xA4); // normal display  
  
    for(i=0;i<64;i++)  
    {  
        for(j=0;j<64;j++)  
        {  
            WriteData(Data_12864greynocolorsbmp[(i<<6)+j]);  
        }  
    }  
}  
  
int main()  
{  
  
    PORTD = 0; // all off  
    DDRD |= (1<<3); // VPP output  
  
    DDRA = 0xFF; // set PORTA for output  
  
    PORTC = 0b11111110;  
  
    DDRC = 0xFE;  
  
    DDRD |= 0x06; // OLED pins output  
  
    delay(20000L);  
  
    init_OLED(); // initialize OLED module  
  
    show_bitmap(); // display image  
  
    while(1);  
  
    return 0;  
}
```



APPENDIX C: OLED MODULE TERMS AND SYMBOLS

Crystalfontz Symbol	Equivalent	Equivalent	Equivalent	Description
C				Capacitor
cd/m ²	nit			Candela meter squared is the standard unit of measurement for luminous intensity (photometric brightness).
CIE				A color model based on human perception developed by the CIE (Commission Internationale de l'Eclairage) committee.
CLS				Clock select pin.
COF	COT	TAB		Chip On Flex. (Chip On Tab.)
COM				Common driver. Common signal output for OLED display.
CR				Contrast Ratio = (brightness with pixels light)/ (brightness with pixels dark).
\overline{CS}	CS#			Chip select input. <i>Low</i> : Controller chip is selected. Communications with host is possible. <i>High</i> : Controller chip is not selected. Host interface signals are ignored by the controller.
D				Diode
DB0 ~ DBn	D0 ~ Dn			Bidirectional databus connects to 8-bit or 16-bit standard host databus. When serial interface is selected, DB0 serves as the serial clock input signal (SCL) and DB1 serves as the serial data input signal (SI). DB2 to DBn are set to high impedance.
D/ \overline{C}	RS	A0	CD or D/C#	Data/Command control. Determines whether data bits are data or command. <i>1 – High</i> : Addresses the data register. <i>0 – Low</i> : Addresses the command register.
FB				Feedback input for the booster circuit. Use to adjust booster output voltage level, V _{PANEL} .
FG				Frame Ground
GDR				Gate Drive. Output signal drives the gate of the external NMOS of the booster circuit.
GND	V _{SS}			Ground. Must be connected to an external ground.



Crystalfontz Symbol	Equivalent	Equivalent	Equivalent	Description															
I_{LOGIC}	I_{DD}			Operating current for V_{LOGIC} .															
$I_{\text{LOGIC, SLEEP}}$	$I_{\text{DD, SLEEP}}$			Sleep mode current for V_{LOGIC} .															
I_{PANEL}	I_{CC}			Supply current for V_{PANEL} .															
$I_{\text{PANEL, SLEEP}}$	$I_{\text{CC, SLEEP}}$			Sleep mode current for V_{PANEL} .															
I_{REF}				Segment output current reference for brightness adjustment. A resistor should be connected between this pin and GND. Used to set the current.															
IS1	BS1	C86	M80	<table border="1"> <thead> <tr> <th>IS1</th> <th>IS2</th> <th>Interface Mode</th> </tr> </thead> <tbody> <tr> <td>0</td> <td>0</td> <td>Serial</td> </tr> <tr> <td>0</td> <td>1</td> <td>6800 Parallel</td> </tr> <tr> <td>1</td> <td>0</td> <td>Not Allowed</td> </tr> <tr> <td>1</td> <td>1</td> <td>8080 Parallel</td> </tr> </tbody> </table>	IS1	IS2	Interface Mode	0	0	Serial	0	1	6800 Parallel	1	0	Not Allowed	1	1	8080 Parallel
IS1	IS2	Interface Mode																	
0	0	Serial																	
0	1	6800 Parallel																	
1	0	Not Allowed																	
1	1	8080 Parallel																	
IS2	BS2	P/S	MS, MS̄ or M/S#																
L_{BR}	IV			Luminous Intensity Brightness.															
NC	nc			No Connection.															
Q				Transistor, including FET and MOSFET.															
R				Resistor															
$\overline{\text{RD}}_{8080}$ (E ₆₈₀₀)	$\overline{\text{RD}}$ (E)	E ($\overline{\text{RD}}$)	E	Host interface input. 8080 Host: Active low. Signal on the databus is latched at the rising edge of $\overline{\text{RD}}$. 6800 Host: Enable control signal input active high. E = High: Read or Write operation is active E = Low: No operation															
$\overline{\text{RST}}$	$\overline{\text{RES}}$	RST#	RES#	Reset signal. Low: Display controller is reset. The $\overline{\text{RST}}$ pin should be pulsed low shortly after power is applied. High: The $\overline{\text{RST}}$ pin should be brought high for normal operation.															
SCL	SCK			Serial Clock signal.															
SEG				Segment driver. Segment signal output for OLED display.															
SENSE				Source current for external NMOS of booster circuit.															



Crystalfontz Symbol	Equivalent	Equivalent	Equivalent	Description
SI	SDA	MOSI		Serial data Input signal.
SW				Switch output drives the gate of the external NMOS of the booster circuit.
T _{OP}	T _a			Operating temperature.
T _{ST}	T _{STG}			Storage temperature.
V _{BREF}				Internal voltage reference for booster circuit. A decoupling capacitor, typically 1μF, should be connected to GND.
V _{COMH}				High level voltage output for common signals. A low ESR capacitor should be connected between this pin and GND. Do not connect external power supply directly to this pin.
V _{IH}	V _{ICH}			High level input voltage.
V _{IL}	V _{LCH}			Low level input voltage.
V _{LOGIC}	V _{DD}	V _{DD1}		Power supply input. Must be connected to an external source.
V _{LOGIC I/O}	V _{DD I/O}	V _{I/O}		Supply voltage for I/O signals.
V _{OH}	V _{OHC}			High level output voltage.
V _{OL}	V _{OLC}			Low level output voltage.
V _{PANEL}	V _{PP}	V _{CC}		<p>Driver supply voltage. Only high voltage input on chip. Power must be supplied externally. <i>Note: You must observe power sequencing for this signal.</i> <i>Power Up</i> – Display must be powered up and initialized before power is applied to the signal. <i>Power Down</i> – Power must be removed from this signal before the display is powered off.</p>



Crystalfontz Symbol	Equivalent	Equivalent	Equivalent	Description
V_{REF}				Voltage reference pin for pre-charge voltage in driving OLED device. Voltage should be set to match with the OLED driving voltage in current drive phase. It can either be supplied externally or by connecting to V_{PANEL} .
V_{SL}				Segment voltage reference pin. This pin should be left open.
\overline{WR}_{8080} (R/\overline{W}_{6800})	R/\overline{W} (\overline{WR})	\overline{WR} (R/\overline{W})	$R/\overline{W}\#$	Host interface input. <i>8080 Host:</i> Active low. Signal on the databus is latched at the rising edge of \overline{WR} signal. <i>6800 Host:</i> Read/Write control signal output. R/\overline{W} = High: Read (Host←Module) R/\overline{W} = Low: Write (Host→Module)



APPENDIX D: SOLOMON SYSTECH SSD1325 CONTROLLER SPECIFICATION SHEET

The complete *Solomon Systech 128 x 80, 16 Gray Scale Dot Matrix OLED/PLED Segment/Common Driver with Controller* Data Sheet (61 pages) follows.

SSD1325

Advance Information

128 x 80, 16 Gray Scale Dot Matrix OLED/PLED Segment/Common Driver with Controller

This document contains information on a new product. Specifications and information herein are subject to change without notice.

<http://www.solomon-systech.com>

SSD1325

Rev 2.1

P 1/61

May 2008

Copyright © 2008 Solomon Systech Limited



**SOLOMON
SYSTECH**



TABLE OF CONTENTS

1	GENERAL DESCRIPTION	6
2	FEATURES	6
3	ORDERING INFORMATION	6
4	BLOCK DIAGRAM	7
5	DIE PAD FLOOR PLAN	8
6	PIN ARRANGEMENT	11
7	PIN DESCRIPTION	13
8	FUNCTIONAL BLOCK DESCRIPTIONS	16
8.1	MPU INTERFACE SELECTION	16
8.1.1	MPU Parallel 6800-series Interface.....	16
8.1.2	MPU Parallel 8080-series Interface.....	17
8.1.3	MPU Serial Interface.....	19
8.2	SEGMENT DRIVERS/COMMON DRIVERS.....	20
8.3	OSCILLATOR CIRCUIT AND DISPLAY TIME GENERATOR.....	23
8.4	COMMAND DECODER AND COMMAND INTERFACE.....	23
8.5	RESET CIRCUIT	24
8.6	CURRENT CONTROL AND VOLTAGE CONTROL	24
8.7	GRAPHIC DISPLAY DATA RAM (GDDRAM).....	24
8.8	GRAY SCALE DECODER.....	27
8.9	POWER ON AND OFF SEQUENCE.....	29
9	COMMAND TABLE	30
9.1	Data Read / Write	35
10	COMMAND DESCRIPTIONS	36
10.1	FUNDAMENTAL COMMAND DESCRIPTION	36
10.1.1	Set Column Address (15h).....	36
10.1.2	Set Row Address (75h).....	36
10.1.3	Set Contrast Current (81h)	37
10.1.4	Set Current Range (84h, 85h, 87h).....	37
10.1.5	Set Re-map (A0h).....	37
10.1.6	Set Display Start Line (A1h)	40
10.1.7	Set Display Offset (A2h).....	41
10.1.8	Set Display Mode (A4h ~ A7h).....	42
10.1.9	Set Multiplex Ratio (A8h).....	43
10.1.10	Set Master Configuration (ADh).....	43
10.1.11	Set Display ON/OFF (AEh / AFh)	43
10.1.12	Set V _{COMH} Voltage (BEh).....	43
10.1.13	Set Precharge Voltage (BCh).....	44
10.1.14	Set Phase Length (B1h).....	44
10.1.15	Set Row Period (B2h).....	44
10.1.16	Set Display Clock Divide Ratio (B3h).....	44
10.1.17	Set Gray Scale Table.....	44
10.1.18	NOP (E3h)	45
10.1.19	Status register Read.....	45
10.2	GRAPHIC ACCELERATION COMMAND SET DESCRIPTION	46
10.2.1	Graphic Acceleration Command Options (23h)	46
10.2.2	Draw Rectangle (24h).....	46
10.2.3	Copy (25h).....	47
10.2.4	Horizontal Scroll (26h).....	47

10.2.5	Stop Moving (2Eh).....	48
10.2.6	Start Moving (2Fh).....	48
11	MAXIMUM RATINGS.....	49
12	DC CHARACTERISTICS.....	50
13	AC CHARACTERISTICS.....	51
14	APPLICATION EXAMPLES.....	55
15	PACKAGE INFORMATION.....	57
15.1	SSD1325Z DIE TRAY INFORMATION.....	57
15.2	SSD1325T6R1 DETAIL DIMENSION.....	59

LIST OF FIGURES

FIGURE 1 : SSD1325 BLOCK DIAGRAM	7
FIGURE 2 : SSD1325Z DIE DRAWING	8
FIGURE 3 : SSD1325Z ALIGNMENT MARK DIMENSIONS	9
FIGURE 4 : SSD1325T6R1 PIN ASSIGNMENT	11
FIGURE 5 : DATA READ BACK PROCEDURE - INSERTION OF DUMMY READ	17
FIGURE 6 : EXAMPLE OF WRITE PROCEDURE IN 8080 PARALLEL INTERFACE MODE	17
FIGURE 7 : EXAMPLE OF READ PROCEDURE IN 8080 PARALLEL INTERFACE MODE	17
FIGURE 8 : DISPLAY DATA READ BACK PROCEDURE - INSERTION OF DUMMY READ	18
FIGURE 9 : DISPLAY DATA WRITE PROCEDURE IN SPI MODE	19
FIGURE 10 : SEGMENT AND COMMON DRIVER BLOCK DIAGRAM	20
FIGURE 11 : SEGMENT AND COMMON DRIVER SIGNAL WAVEFORM	21
FIGURE 12 : GRAY SCALE CONTROL BY PWM IN SEGMENT	22
FIGURE 13 : OSCILLATOR CIRCUIT	23
FIGURE 14 : I _{REF} CURRENT SETTING BY RESISTOR VALUE	24
FIGURE 15 : GRAY SCALE PULSE WIDTH SET DIAGRAM	28
FIGURE 16 : THE POWER ON SEQUENCE	29
FIGURE 17 : THE POWER OFF SEQUENCE	29
FIGURE 18 : EXAMPLE OF COLUMN AND ROW ADDRESS POINTER MOVEMENT	36
FIGURE 19 : SEGMENT CURRENT VS CONTRAST SETTING	37
FIGURE 20 : ADDRESS POINTER MOVEMENT OF HORIZONTAL ADDRESS INCREMENT MODE	38
FIGURE 21 : ADDRESS POINTER MOVEMENT OF VERTICAL ADDRESS INCREMENT MODE	38
FIGURE 22 : OUTPUT PIN ASSIGNMENT WHEN COMMAND A0H BIT A[6]=0	39
FIGURE 23 : OUTPUT PIN ASSIGNMENT WHEN COMMAND A0H BIT A[6]=1	39
FIGURE 24 : EXAMPLE OF SET DISPLAY START LINE WITH NO REMAPPING	40
FIGURE 25 : EXAMPLE OF SET DISPLAY OFFSET WITH NO REMAPPING	41
FIGURE 26 : EXAMPLE OF NORMAL DISPLAY	42
FIGURE 27 : EXAMPLE OF ENTIRE DISPLAY ON	42
FIGURE 28 : EXAMPLE OF ENTIRE DISPLAY OFF	42
FIGURE 29 : EXAMPLE OF INVERSE DISPLAY	42
FIGURE 30 : EXAMPLE OF GAMMA CORRECTION BY GRAY SCALE TABLE SETTING	44
FIGURE 31 : EXAMPLE OF DRAW RECTANGLE COMMAND	46
FIGURE 32 : EXAMPLE OF COPY COMMAND	47
FIGURE 33 : SCROLLING EXAMPLES	47
FIGURE 34 : 6800-SERIES MPU PARALLEL INTERFACE CHARACTERISTICS	52
FIGURE 35 : 8080-SERIES PARALLEL INTERFACE CHARACTERISTICS (FORM 1)	53
FIGURE 36 : 8080-SERIES PARALLEL INTERFACE CHARACTERISTICS (FORM 2)	53
FIGURE 37 : SERIAL INTERFACE CHARACTERISTICS	54
FIGURE 38 : APPLICATION EXAMPLE FOR SSD1325Z SPI SERIAL INTERFACE MODE	55
FIGURE 39 : APPLICATION EXAMPLE FOR SSD1325T6R1	56
FIGURE 40 : SSD1325Z DIE TRAY DRAWING	57
FIGURE 41 : SSD1325T6R1 DETAIL DIMENSION	59

LIST OF TABLES

TABLE 1 : ORDERING INFORMATION.....	6
TABLE 2 : SSD1325Z BUMP DIE PAD COORDINATES.....	10
TABLE 3: SSD1325T6R1 TAB PIN ASSIGNMENT TABLE.....	12
TABLE 4: PIN DESCRIPTIONS	13
TABLE 5 : BUS INTERFACE SELECTION.....	13
TABLE 6 : MCU INTERFACE ASSIGNMENT UNDER DIFFERENT BUS INTERFACE MODE	16
TABLE 7: CONTROL PINS OF 6800 INTERFACE.....	16
TABLE 8: CONTROL PINS OF 8080 INTERFACE (FORM 1).....	18
TABLE 9: CONTROL PINS OF 8080 INTERFACE (FORM 2).....	18
TABLE 10: CONTROL PINS OF SERIAL INTERFACE	19
TABLE 11 : GDDRAM ADDRESS MAP 1.....	25
TABLE 12 : GDDRAM ADDRESS MAP 2.....	25
TABLE 13 : GDDRAM ADDRESS MAP 3.....	26
TABLE 14 : GDDRAM ADDRESS MAP 4.....	26
TABLE 15 : GDDRAM ADDRESS MAP 5.....	27
TABLE 16 : GRAY SCALE PULSE WIDTH SET TABLE	27
TABLE 17 : GRAY SCALE PULSE WIDTH DEFAULT VALUES	28
TABLE 18: COMMAND TABLE.....	30
TABLE 19: GRAPHIC ACCELERATION COMMAND	33
TABLE 20: READ COMMAND TABLE.....	34
TABLE 21: ADDRESS INCREMENT TABLE (AUTOMATIC).....	35
TABLE 22 : MAXIMUM RATINGS (VOLTAGE REFERENCE TO V _{SS}).....	49
TABLE 23 : DC CHARACTERISTICS	50
TABLE 24 : AC CHARACTERISTICS	51
TABLE 25 : 6800-SERIES MPU PARALLEL INTERFACE TIMING CHARACTERISTICS	52
TABLE 26 : 8080-SERIES MPU PARALLEL INTERFACE TIMING CHARACTERISTICS	53
TABLE 27 : SERIAL INTERFACE TIMING CHARACTERISTICS	54
TABLE 28 : SSD1325Z DIE TRAY DIMENSIONS.....	58

1 GENERAL DESCRIPTION

SSD1325 is a single-chip CMOS OLED/PLED driver with controller for organic/polymer light emitting diode dot-matrix graphic display system. It consists of 208 high voltage/current driving output pins for driving 128 segments and 80 commons. This IC is designed for Common Cathode type OLED/PLED panel.

SSD1325 displays data directly from its internal 128x80x4 bits Graphic Display Data RAM (GDDRAM). Data/Commands are sent from general MCU through the hardware selectable 6800-/8080-series compatible Parallel Interface or Serial Peripheral Interface.

It has a 128-step contrast control and a 16 gray level control. The embedded on-chip oscillator and DC-DC voltage converter reduce the number of external components.

2 FEATURES

- Support max. 128 x 80 matrix panel
- Power supply: $V_{DD} = 2.4V - 3.5V$
 $V_{CC} = 8.0V - 16.0V$
- For matrix display:
 - OLED driving output voltage, 14V maximum
 - Can output maximum segment source current: 300uA
 - Common maximum sink current: 40mA
- Embedded 128 x 80 x 4 bit SRAM display memory
- 128 step contrast current control on monochrome passive OLED panel
- 16 gray scale
- Internal Oscillator
- Programmable Frame Rate
- 8-bit 6800-series Parallel Interface, 8080-series Parallel Interface, Serial Peripheral Interface.
- Row re-mapping and Column re-mapping
- Low power consumption (<5.0uA @sleep mode)
- Wide range of operating temperature: -40 to 85 °C

3 ORDERING INFORMATION

Table 1 : Ordering Information

Ordering Part Number	SEG	COM	Package Form	Reference	Remarks
SSD1325Z	128	80	COG	Page 8, 57	<ul style="list-style-type: none">• Min SEG pad pitch: 52.2um• Min COM pad pitch: 51.8um
SSD1325T6R1	128	80	TAB	Page 58	<ul style="list-style-type: none">• 8-bit 80 / 68 / SPI interface• Output lead pitch: 0.12mm x 0.998 = 0.11976mm• 4 SPH, 35m film• Full resolution 128 x 80

4 BLOCK DIAGRAM

Figure 1 : SSD1325 Block Diagram

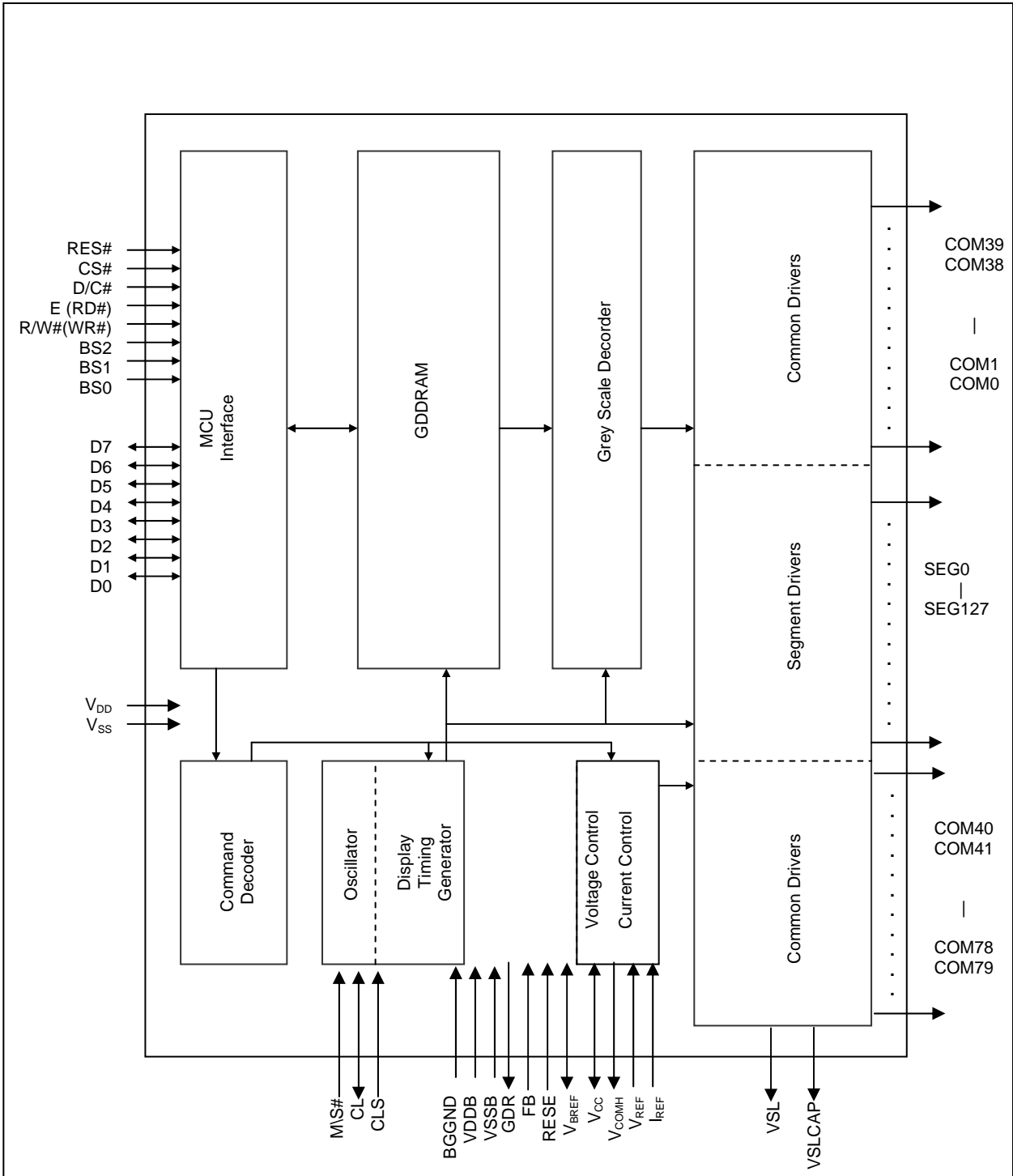

5 DIE PAD FLOOR PLAN

Figure 2 : SSD1325Z Die Drawing

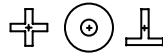
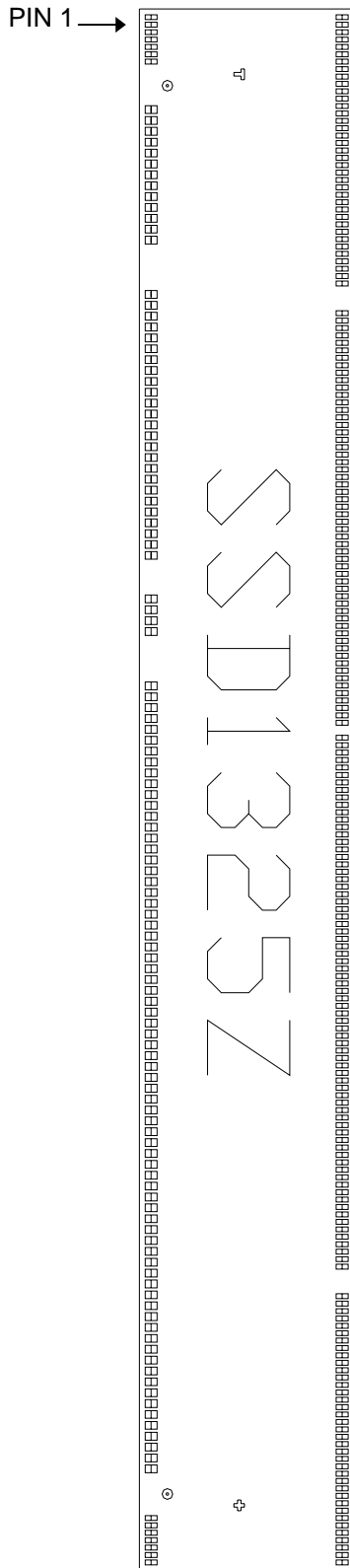

Note

¹ + represents the centre of the alignment mark

Alignment Mark	X-pos (μm)	Y-pos (μm)
o Shape	4934.100	-557.675
	-4934.100	-557.675
+ shape	5014.100	-52.200
T shape	-5014.100	-52.200

Die Size	10942 μm x 1508 μm
Die Thickness	457 +/- 25 μm
I/O pad pitch	76.2 μm
SEG pad pitch	52.2 μm
COM pad pitch	51.8 μm
Bump Height	Nominal 18 μm

Bump size	X (μm)	Y (μm)
Pad 1-7,123-331	34	84
Pad 8-122	54	84

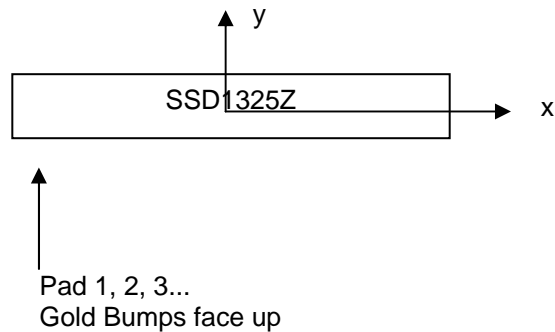

Figure 3 : SSD1325Z Alignment Mark Dimensions

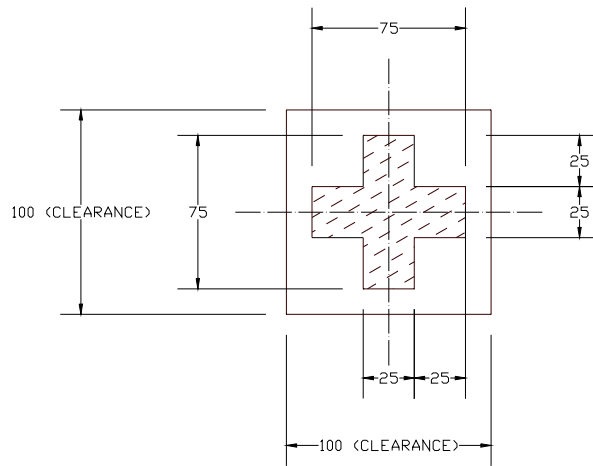
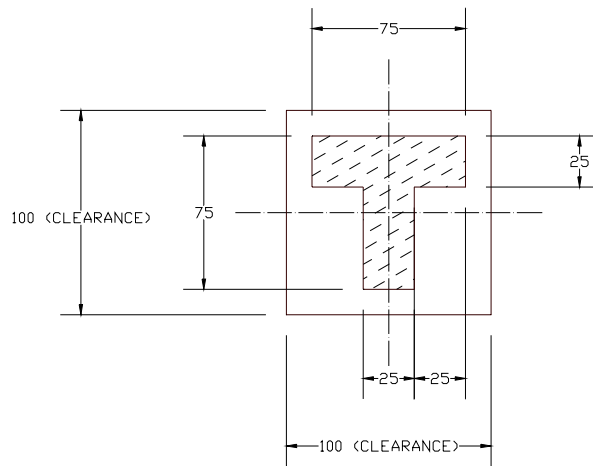

Table 2 : SSD1325Z Bump Die Pad Coordinates

Pad#	Signal	X-pos	Y-pos	Pad#	Signal	X-pos	Y-pos	Pad#	Signal	X-pos	Y-pos	Pad#	Signal	X-pos	Y-pos
1	DUMMY	-5414.000	-672.075	91	VDD	2395.725	-672.075	181	SEG14	2610.000	672.075	271	SEG104	-2140.200	672.075
2	DUMMY	-5361.800	-672.075	92	ICAS	2471.925	-672.075	182	SEG15	2557.800	672.075	272	SEG105	-2192.400	672.075
3	COM75	-5309.600	-672.075	93	REF	2548.125	-672.075	183	SEG16	2505.600	672.075	273	SEG106	-2244.600	672.075
4	COM76	-5257.800	-672.075	94	VCOMH	2624.325	-672.075	184	SEG17	2453.400	672.075	274	SEG107	-2296.800	672.075
5	COM77	-5206.000	-672.075	95	VCOMH	2700.525	-672.075	185	SEG18	2401.200	672.075	275	SEG108	-2349.000	672.075
6	COM78	-5154.200	-672.075	96	VREF	2776.725	-672.075	186	SEG19	2349.000	672.075	276	SEG109	-2401.200	672.075
7	COM79	-5102.400	-672.075	97	VCC	2852.925	-672.075	187	SEG20	2296.800	672.075	277	SEG110	-2453.400	672.075
8	DUMMY	-4767.075	-672.075	98	VCC	2929.125	-672.075	188	SEG21	2244.600	672.075	278	SEG111	-2505.600	672.075
9	DUMMY	-4690.875	-672.075	99	VDD	3005.325	-672.075	189	SEG22	2192.400	672.075	279	SEG112	-2557.800	672.075
10	DUMMY	-4614.675	-672.075	100	VSL	3081.525	-672.075	190	SEG23	2140.200	672.075	280	SEG113	-2610.000	672.075
11	DUMMY	-4538.475	-672.075	101	VSS	3157.725	-672.075	191	SEG24	2088.000	672.075	281	SEG114	-2662.200	672.075
12	DUMMY	-4462.275	-672.075	102	VCL	3233.925	-672.075	192	SEG25	2035.800	672.075	282	SEG115	-2714.400	672.075
13	DUMMY	-4386.075	-672.075	103	VCL	3310.125	-672.075	193	SEG26	1983.600	672.075	283	SEG116	-2766.600	672.075
14	DUMMY	-4309.875	-672.075	104	VCL	3386.325	-672.075	194	SEG27	1931.400	672.075	284	SEG117	-2818.800	672.075
15	DUMMY	-4233.675	-672.075	105	DUMMY	3462.525	-672.075	195	SEG28	1879.200	672.075	285	SEG118	-2871.000	672.075
16	DUMMY	-4157.475	-672.075	106	DUMMY	3538.725	-672.075	196	SEG29	1827.000	672.075	286	SEG119	-2923.200	672.075
17	DUMMY	-4081.275	-672.075	107	DUMMY	3614.925	-672.075	197	SEG30	1774.800	672.075	287	SEG120	-2975.400	672.075
18	DUMMY	-4005.075	-672.075	108	DUMMY	3691.125	-672.075	198	SEG31	1722.600	672.075	288	SEG121	-3027.600	672.075
19	DUMMY	-3928.875	-672.075	109	DUMMY	3767.325	-672.075	199	SEG32	1670.400	672.075	289	SEG122	-3079.800	672.075
20	DUMMY	-3852.675	-672.075	110	DUMMY	3843.525	-672.075	200	SEG33	1618.200	672.075	290	SEG123	-3132.000	672.075
21	VCL	-3471.675	-672.075	111	DUMMY	3919.725	-672.075	201	SEG34	1566.000	672.075	291	SEG124	-3184.200	672.075
22	VCL	-3395.475	-672.075	112	DUMMY	3995.925	-672.075	202	SEG35	1513.800	672.075	292	SEG125	-3236.400	672.075
23	VCL	-3319.275	-672.075	113	DUMMY	4072.125	-672.075	203	SEG36	1461.600	672.075	293	SEG126	-3288.600	672.075
24	VSS	-3243.075	-672.075	114	DUMMY	4148.325	-672.075	204	SEG37	1409.400	672.075	294	SEG127	-3340.800	672.075
25	VSSB	-3166.875	-672.075	115	DUMMY	4224.525	-672.075	205	SEG38	1357.200	672.075	295	COM40	-3548.400	672.075
26	VSSB	-3090.675	-672.075	116	DUMMY	4300.725	-672.075	206	SEG39	1305.000	672.075	296	COM41	-3600.200	672.075
27	VSL	-3014.475	-672.075	117	DUMMY	4376.925	-672.075	207	SEG40	1252.800	672.075	297	COM42	-3652.000	672.075
28	VSLCAP	-2938.275	-672.075	118	DUMMY	4453.125	-672.075	208	SEG41	1200.600	672.075	298	COM43	-3703.800	672.075
29	VSLCAP	-2862.075	-672.075	119	DUMMY	4529.325	-672.075	209	SEG42	1148.400	672.075	299	COM44	-3755.600	672.075
30	VDD	-2785.875	-672.075	120	DUMMY	4605.525	-672.075	210	SEG43	1096.200	672.075	300	COM45	-3807.400	672.075
31	VCC	-2709.675	-672.075	121	DUMMY	4681.725	-672.075	211	SEG44	1044.000	672.075	301	COM46	-3859.200	672.075
32	VCC	-2633.475	-672.075	122	DUMMY	4757.925	-672.075	212	SEG45	991.800	672.075	302	COM47	-3911.000	672.075
33	VCOMH	-2557.275	-672.075	123	COM39	5102.400	-672.075	213	SEG46	939.600	672.075	303	COM48	-3962.800	672.075
34	VCOMH	-2481.075	-672.075	124	COM38	5154.200	-672.075	214	SEG47	887.400	672.075	304	COM49	-4014.600	672.075
35	IR8	-2404.875	-672.075	125	COM37	5206.000	-672.075	215	SEG48	835.200	672.075	305	COM50	-4066.400	672.075
36	IR7	-2328.675	-672.075	126	COM36	5257.800	-672.075	216	SEG49	783.000	672.075	306	COM51	-4118.200	672.075
37	IR6	-2252.475	-672.075	127	COM35	5309.600	-672.075	217	SEG50	730.800	672.075	307	COM52	-4170.000	672.075
38	IR5	-2176.275	-672.075	128	DUMMY	5361.800	-672.075	218	SEG51	678.600	672.075	308	COM53	-4221.800	672.075
39	IR4	-2100.075	-672.075	129	DUMMY	5414.000	-672.075	219	SEG52	626.400	672.075	309	COM54	-4273.600	672.075
40	IR3	-2023.875	-672.075	130	DUMMY	5414.000	672.075	220	SEG53	574.200	672.075	310	COM55	-4325.400	672.075
41	IR2	-1947.675	-672.075	131	DUMMY	5361.800	672.075	221	SEG54	522.000	672.075	311	COM56	-4377.200	672.075
42	IR1	-1871.475	-672.075	132	COM34	5309.600	672.075	222	SEG55	469.800	672.075	312	COM57	-4429.000	672.075
43	IR0	-1795.275	-672.075	133	COM33	5257.800	672.075	223	SEG56	417.600	672.075	313	COM58	-4480.800	672.075
44	VSS	-1719.075	-672.075	134	COM32	5206.000	672.075	224	SEG57	365.400	672.075	314	COM59	-4532.600	672.075
45	VSSB	-1642.875	-672.075	135	COM31	5154.200	672.075	225	SEG58	313.200	672.075	315	COM60	-4584.400	672.075
46	GDR	-1338.075	-672.075	136	COM30	5102.400	672.075	226	SEG59	261.000	672.075	316	COM61	-4636.200	672.075
47	GDR	-1261.875	-672.075	137	COM29	5050.600	672.075	227	SEG60	208.800	672.075	317	COM62	-4688.000	672.075
48	GDR	-1185.675	-672.075	138	COM28	4998.800	672.075	228	SEG61	156.600	672.075	318	COM63	-4739.800	672.075
49	GDR	-1109.475	-672.075	139	COM27	4947.000	672.075	229	SEG62	104.400	672.075	319	COM64	-4791.600	672.075
50	VDD	-728.475	-672.075	140	COM26	4895.200	672.075	230	SEG63	52.200	672.075	320	COM65	-4843.400	672.075
51	VDD	-652.275	-672.075	141	COM25	4843.400	672.075	231	SEG64	0.000	672.075	321	COM66	-4895.200	672.075
52	VDD	-576.075	-672.075	142	COM24	4791.600	672.075	232	SEG65	-52.200	672.075	322	COM67	-4947.000	672.075
53	VDD	-499.875	-672.075	143	COM23	4739.800	672.075	233	SEG66	-104.400	672.075	323	COM68	-4998.800	672.075
54	FB	-423.675	-672.075	144	COM22	4688.000	672.075	234	SEG67	-156.600	672.075	324	COM69	-5050.600	672.075
55	RESE	-347.475	-672.075	145	COM21	4636.200	672.075	235	SEG68	-208.800	672.075	325	COM70	-5102.400	672.075
56	VBREF	-271.275	-672.075	146	COM20	4584.400	672.075	236	SEG69	-261.000	672.075	326	COM71	-5154.200	672.075
57	BGND	-195.075	-672.075	147	COM19	4532.600	672.075	237	SEG70	-313.200	672.075	327	COM72	-5206.000	672.075
58	VSS	-118.875	-672.075	148	COM18	4480.800	672.075	238	SEG71	-365.400	672.075	328	COM73	-5257.800	672.075
59	VCC	-42.675	-672.075	149	COM17	4429.000	672.075	239	SEG72	-417.600	672.075	329	COM74	-5309.600	672.075
60	GPO0	33.525	-672.075	150	COM16	4377.200	672.075	240	SEG73	-469.800	672.075	330	DUMMY	-5361.800	672.075
61	GPI01	109.725	-672.075	151	COM15	4325.400	672.075	241	SEG74	-522.000	672.075	331	DUMMY	-5414.000	672.075
62	VDD	185.925	-672.075	152	COM14	4273.600	672.075	242	SEG75	-574.200	672.075				
63	BS0	262.125	-672.075	153	COM13	4221.800	672.075	243	SEG76	-626.400	672.075				
64	VSS	338.325	-672.075	154	COM12	4170.000	672.075	244	SEG77	-678.600	672.075				
65	BS1	414.525	-672.075	155	COM11	4118.200	672.075	245	SEG78	-730.800	672.075				
66	VDD	490.725	-672.075	156	COM10	4066.400	672.075	246	SEG79	-783.000	672.075				
67	BS2	566.925	-672.075	157	COM9	4014.600	672.075	247	SEG80	-835.200	672.075				
68	VSS	643.125	-672.075	158	COM8	3962.800	672.075	248	SEG81	-887.400	672.075				
69	FR	719.325	-672.075	159	COM7	3911.000	672.075	249	SEG82	-939.600	672.075				
70	CL	795.525	-672.075	160	COM6	3859.200	672.075	250	SEG83	-991.800	672.075				
71	DOF#	871.725	-672.075	161	COM5	3807.400	672.075	251	SEG84	-1044.000	672.075				
72	VSS	947.925	-672.075	162	COM4	3755.600	672.075	252	SEG85	-1096.200	672.075				
73	CS#	1024.125	-672.075	163	COM3	3703.800	672.075	253	SEG86	-1148.400	672.075				
74	RES#	1100.325	-672.075	164	COM2	3652.000	672.075	254	SEG87	-1200.600	672.075				
75	D/C#	1176.525	-672.075	165	COM1	3600.200	672.075	255	SEG88	-1252.800	672.075				
76	VSS	1252.725	-672.075	166	COM0	3548.400	672.075	256	SEG89	-1305.000	672.075				
77	RW#(WR#)	132													

6 PIN ARRANGEMENT

6.1 SSD1325T6R1 pin assignment

Figure 4 : SSD1325T6R1 Pin Assignment

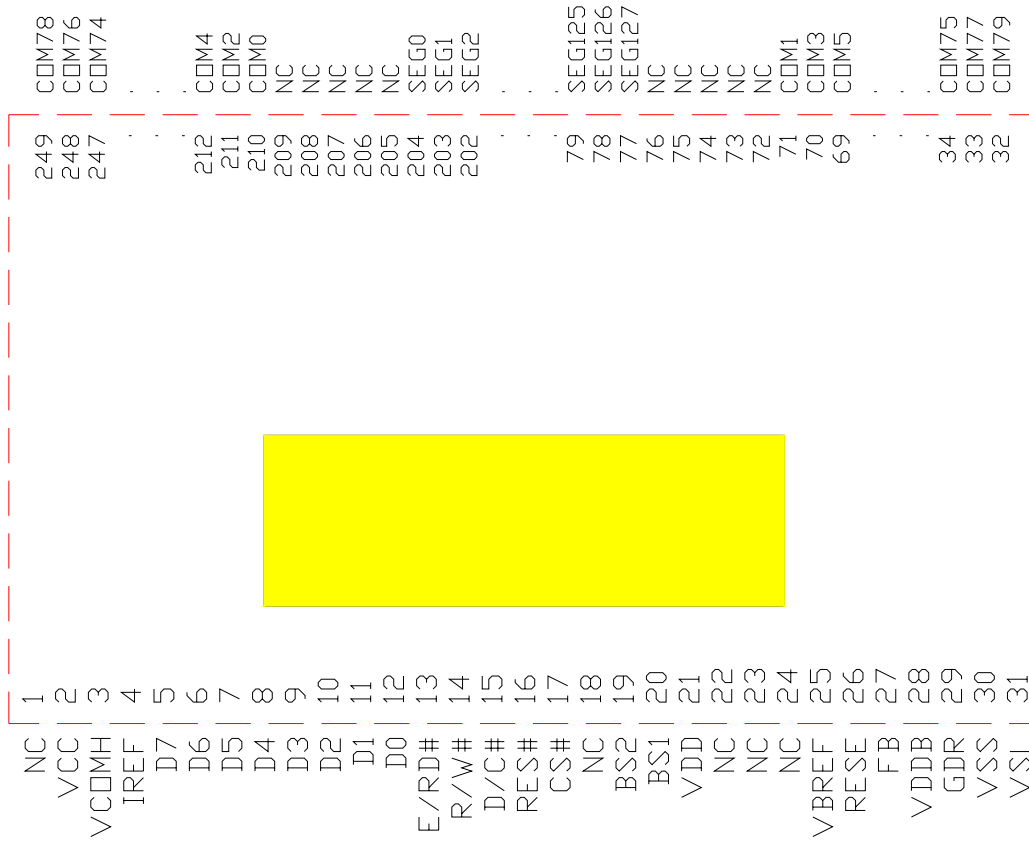

Table 3: SSD1325T6R1 TAB Pin assignment Table

PIN NO.	PIN NAME	PIN NO.	PIN NAME	PIN NO.	PIN NAME	PIN NO.	PIN NAME
1	NC	81	SEG125	161	SEG43	241	COM62
2	VCC	82	SEG122	162	SEG42	242	COM64
3	VCOMH	83	SEG121	163	SEG41	243	COM66
4	IREF	84	SEG120	164	SEG40	244	COM68
5	D7	85	SEG119	165	SEG39	245	COM70
6	D6	86	SEG118	166	SEG38	246	COM72
7	D5	87	SEG117	167	SEG37	247	COM74
8	D4	88	SEG116	168	SEG36	248	COM76
9	D3	89	SEG115	169	SEG35	249	COM78
10	D2	90	SEG114	170	SEG34		
11	D1	91	SEG113	171	SEG33		
12	D0	92	SEG112	172	SEG32		
13	E/RD#	93	SEG111	173	SEG31		
14	R/W#	94	SEG110	174	SEG30		
15	D/C#	95	SEG109	175	SEG29		
16	RES#	96	SEG108	176	SEG28		
17	CS#	97	SEG107	177	SEG27		
18	NC	98	SEG106	178	SEG26		
19	BS2	99	SEG105	179	SEG25		
20	BS1	100	SEG104	180	SEG24		
21	VDD	101	SEG103	181	SEG23		
22	NC	102	SEG102	182	SEG22		
23	NC	103	SEG101	183	SEG21		
24	NC	104	SEG100	184	SEG20		
25	VBREF	105	SEG99	185	SEG19		
26	RESE	106	SEG98	186	SEG18		
27	FR	107	SEG97	187	SEG17		
28	VDDB	108	SEG96	188	SEG16		
29	GDR	109	SEG95	189	SEG15		
30	VSS	110	SEG94	190	SEG14		
31	VSL	111	SEG93	191	SEG13		
32	COM9	112	SEG92	192	SEG12		
33	COM7	113	SEG91	193	SEG11		
34	COM5	114	SEG90	194	SEG10		
35	COM3	115	SEG89	195	SEG9		
36	COM1	116	SEG88	196	SEG8		
37	COM9	117	SEG87	197	SEG7		
38	COM6	118	SEG86	198	SEG6		
39	COM5	119	SEG85	199	SEG5		
40	COM3	120	SEG84	200	SEG4		
41	COM1	121	SEG83	201	SEG3		
42	COM9	122	SEG82	202	SEG2		
43	COM7	123	SEG81	203	SEG1		
44	COM5	124	SEG80	204	SEG0		
45	COM3	125	SEG79	205	NC		
46	COM1	126	SEG78	206	NC		
47	COM9	127	SEG77	207	NC		
48	COM7	128	SEG76	208	NC		
49	COM5	129	SEG75	209	NC		
50	COM3	130	SEG74	210	COM0		
51	COM1	131	SEG73	211	COM2		
52	COM9	132	SEG72	212	COM4		
53	COM7	133	SEG71	213	COM6		
54	COM5	134	SEG70	214	COM8		
55	COM3	135	SEG69	215	COM10		
56	COM1	136	SEG68	216	COM12		
57	COM9	137	SEG67	217	COM14		
58	COM7	138	SEG66	218	COM16		
59	COM5	139	SEG65	219	COM18		
60	COM3	140	SEG64	220	COM20		
61	COM1	141	SEG63	221	COM22		
62	COM9	142	SEG62	222	COM24		
63	COM7	143	SEG61	223	COM26		
64	COM5	144	SEG60	224	COM28		
65	COM3	145	SEG59	225	COM30		
66	COM1	146	SEG58	226	COM32		
67	COM9	147	SEG57	227	COM34		
68	COM7	148	SEG56	228	COM36		
69	COM5	149	SEG55	229	COM38		
70	COM3	150	SEG54	230	COM40		
71	COM1	151	SEG53	231	COM42		
72	NC	152	SEG52	232	COM44		
73	NC	153	SEG51	233	COM46		
74	NC	154	SEG50	234	COM48		
75	NC	155	SEG49	235	COM50		
76	NC	156	SEG48	236	COM52		
77	SEG127	157	SEG47	237	COM54		
78	SEG126	158	SEG46	238	COM56		
79	SEG125	159	SEG45	239	COM58		
80	SEG124	160	SEG44	240	COM60		

7 PIN DESCRIPTION

Key:

I = Input	NC = Not Connected
O = Output	Pull LOW = Connect to Ground
IO = Bi-directional (input/output)	Pull HIGH = Connect to V _{DD}
P = Power pin	

Table 4: Pin Descriptions

Pin Name	Pin Type	Description																
RES#	I	This pin is reset signal input. When the pin is LOW, initialization of the chip is executed. Keep this pin HIGH during normal operation.																
CS#	I	This pin is the chip select input. The chip is enabled for MCU communication only when CS# is pulled LOW.																
D/C#	I	This pin is Data/Command control pin. When the pin is pulled HIGH, the data at D[7:0] is treated as data. When the pin is pulled LOW, the data at D[7:0] will be transferred to the command register. For detail relationship to MCU interface signals, please refer to the Timing Characteristics Diagrams in Figure 34 to Figure 37.																
E (RD#)	I	This pin is MCU interface input. When interfacing to a 6800-series microprocessor, this pin will be used as the Enable (E) signal. Read/write operation is initiated when this pin is pulled HIGH and the chip is selected. When connecting to an 8080-microprocessor, this pin receives the Read (RD#) signal. Data read operation is initiated when this pin is pulled LOW and the chip is selected.																
R/W# (WR#)	I	This pin is MCU interface input. When interfacing to a 6800-series microprocessor, this pin will be used as Read/Write (R/W#) selection input. Read mode will be carried out when this pin is pulled HIGH and write mode will be carried out when LOW. When 8080 interface mode is selected, this pin will be the Write (WR#) input. Data write operation is initiated when this pin is pulled LOW and the chip is selected.																
D[7:0]	IO	These pins are 8-bit bi-directional data bus to be connected to the microprocessor's data bus. When serial mode is selected, D1 will be the serial data input SDIN and D0 will be the serial clock input SCLK.																
BS[2:0]	I	These pins are MCU bus interface selection. Table 5 : Bus Interface selection <table border="1" style="margin-left: auto; margin-right: auto;"> <thead> <tr> <th></th> <th>6800-parallel interface (8 bit)</th> <th>8080-parallel interface (8 bit)</th> <th>Serial interface</th> </tr> </thead> <tbody> <tr> <td>BS0</td> <td>0</td> <td>0</td> <td>0</td> </tr> <tr> <td>BS1</td> <td>0</td> <td>1</td> <td>0</td> </tr> <tr> <td>BS2</td> <td>1</td> <td>1</td> <td>0</td> </tr> </tbody> </table> Note (1) 0 is connected to V _{SS} (2) 1 is connected to V _{DD}		6800-parallel interface (8 bit)	8080-parallel interface (8 bit)	Serial interface	BS0	0	0	0	BS1	0	1	0	BS2	1	1	0
	6800-parallel interface (8 bit)	8080-parallel interface (8 bit)	Serial interface															
BS0	0	0	0															
BS1	0	1	0															
BS2	1	1	0															
V _{DD}	P	This is a power supply pin. It must be connected to external source.																
V _{SS}	P	This is a ground pin. It also acts as ground reference for the logic pins. It must be connected to external ground.																
CL	IO	This pin is the system clock input. When internal oscillator is disabled (i.e. CLS is pulled LOW), this pin receives display clock signal from external clock source. When internal																

Pin Name	Pin Type	Description
		clock is enabled (i.e. CLS is pulled HIGH), this pin should be kept NC and left open.
CLS	I	This is the internal clock enable pin. When this pin is pulled HIGH, internal oscillator is selected. The internal clock will be disabled when it is pulled LOW, an external clock source must be connected to CL pin for normal operation.
V _{CC}	P	This pin is the most positive voltage supply of the chip. It is supplied by external high voltage source.
V _{COMH}	P	A capacitor should be connected between this pin and V _{SS} . No external power supply is allowed to connect to this pin.
I _{REF}	I	This pin is the segment output current reference pin. I _{SEG} is derived from I _{REF} . A resistor should be connected between this pin and V _{SS} to maintain the current around 10uA.
COM0 ~ COM79	O	These pins provide the Common switch signals to the OLED panel. These pins are in high impedance state when display is OFF.
SEG0 ~ SEG127	O	These pins provide the OLED segment driving signals. These pins are in high impedance state when display is OFF.
V _{REF}	P	This pin is the voltage reference for the pre-charge voltage in driving OLED device. Voltage should be set matching with the OLED driving voltage in the current drive phase. It can be either supplied externally or connected to V _{CC} .
VCL	O	This is the output pin for the voltage output low level for COM signals. This pin should be connected to V _{SS} .
VSL	O	This is the output pin for the voltage output low level for SEG signals. This pin can be kept NC or connected with a capacitor to V _{SS} for stability. Refer to command BFh for VSL pin connection details.
VSLCAP	O	This is a reserved pin. It has to be kept NC and left open.
M/S#	I	This pin is an input pin and must be pulled HIGH to enable the chip function.
VDDDB	P	This is a reserved pin. It should be connected to V _{DD} .
VSSB	P	This is a reserved pin. It should be connected to V _{SS} .
GDR	O	This is a reserved pin. It should be kept NC.
RESE	I	This is a reserved pin. It should be kept NC.
FB	I	This is a reserved pin. It should be kept NC.
VBREF	I	This is an internal voltage reference pin. It should be kept NC and left open.
FR	-	It is No Connection pin. It should be kept NC and left open.
DOF#	-	It is No Connection pin. It should be kept NC and left open.
GPIO0	IO	This is a reserved pin. It should be kept NC and left open.
GPIO1	IO	This is a reserved pin. It should be kept NC and left open.

Pin Name	Pin Type	Description
TR[8:0]	-	This is a reserved pin. It should be kept NC and left open.
ICAS	-	This is a reserved pin. It should be kept NC and left open.

8 FUNCTIONAL BLOCK DESCRIPTIONS

8.1 MPU Interface selection

SSD1325 MCU interface consist of 8 data pins and 5 control pins. The pin assignment at different interface mode is summarized in Table 6. Different MCU mode can be set by hardware selection on BS[2:0] pins (please refer to Table 5 for BS[2:0] setting).

Table 6 : MCU interface assignment under different bus interface mode

Pin Name Bus Interface	Data/Command Interface								Control Signal				
	D7	D6	D5	D4	D3	D2	D1	D0	E	R/W#	CS#	D/C#	RES#
8-bit 8080	D[7:0]								RD#	WR#	CS#	D/C#	RES#
8-bit 6800	D[7:0]								E	R/W#	CS#	D/C#	RES#
SPI	Tie LOW				NC	SDIN	SCLK	Tie LOW		CS#	D/C#	RES#	

8.1.1 MPU Parallel 6800-series Interface

The parallel interface consists of 8 bi-directional data pins (D[7:0]), R/W#, D/C#, E and CS#.

A LOW in R/W# indicates WRITE operation and HIGH in R/W# indicates READ operation.

A LOW in D/C# indicates COMMAND read/write and HIGH in D/C# indicates DATA read/write.

The E input serves as data latch signal while CS# is LOW. Data is latched at the falling edge of E signal.

Table 7: Control pins of 6800 interface

Function	E	R/W#	CS#	D/C#
Write command	↓	L	L	L
Read status	↓	H	L	L
Write data	↓	L	L	H
Read data	↓	H	L	H

Note

⁽¹⁾↓ stands for falling edge of signal

H stands for HIGH in signal

L stands for LOW in signal

In order to match the operating frequency of display RAM with that of the microprocessor, some pipeline processing is internally performed which requires the insertion of a dummy read before the first actual display data read. This is shown in Figure 5.

Figure 5 : Data read back procedure - insertion of dummy read

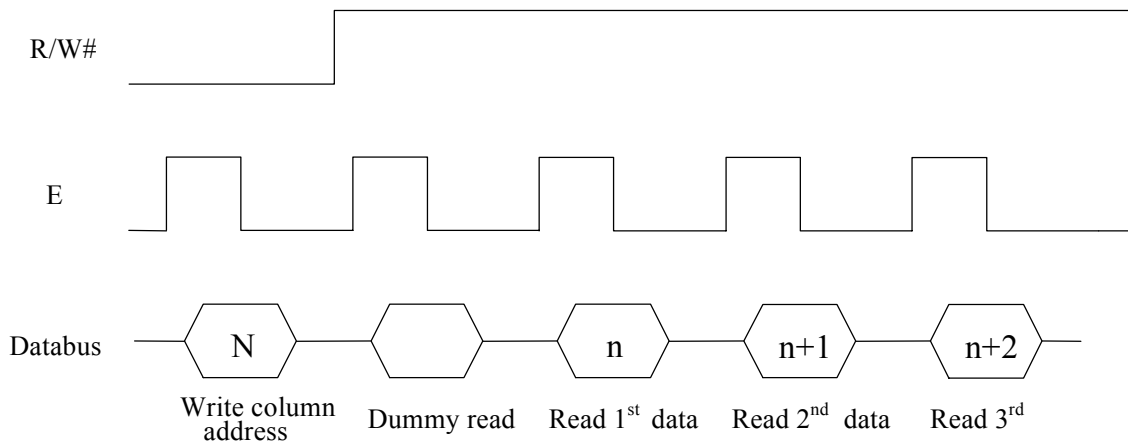

8.1.2 MPU Parallel 8080-series Interface

The parallel interface consists of 8 bi-directional data pins (D[7:0]), RD#, WR#, D/C# and CS#.

A LOW in D/C# indicates COMMAND read/write and HIGH in D/C# indicates DATA read/write.

A rising edge of RD# input serves as a data READ latch signal while CS# is kept LOW.

A rising edge of WR# input serves as a data/command WRITE latch signal while CS# is kept LOW.

Figure 6 : Example of Write procedure in 8080 parallel interface mode

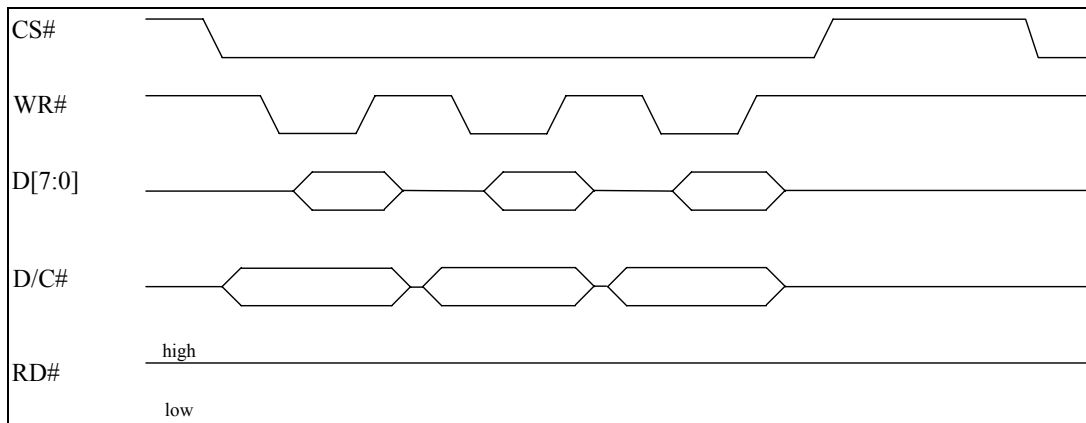

Figure 7 : Example of Read procedure in 8080 parallel interface mode

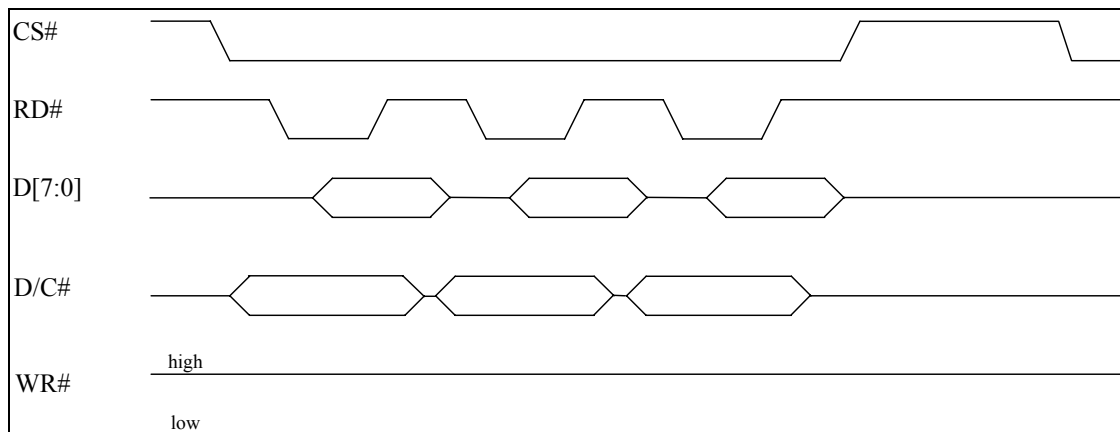

Table 8: Control pins of 8080 interface (Form 1)

Function	RD#	WR#	CS#	D/C#
Write command	H	↑	L	L
Read status	↑	H	L	L
Write data	H	↑	L	H
Read data	↑	H	L	H

Note

- (1) ↑ stands for rising edge of signal
- (2) H stands for HIGH in signal
- (3) L stands for LOW in signal
- (4) Refer to Figure 35 for Form 1 8080-Series MPU Parallel Interface Timing Characteristics

Alternatively, RD# and WR# can be keep stable while CS# serves as the data/command latch signal.

Table 9: Control pins of 8080 interface (Form 2)

Function	RD#	WR#	CS#	D/C#
Write command	H	L	↑	L
Read status	L	H	↑	L
Write data	H	L	↑	H
Read data	L	H	↑	H

Note

- (1) ↑ stands for rising edge of signal
- (2) H stands for HIGH in signal
- (3) L stands for LOW in signal
- (4) Refer to Figure 36 for Form 2 8080-Series MPU Parallel Interface Timing Characteristics

In order to match the operating frequency of display RAM with that of the microprocessor, some pipeline processing is internally performed which requires the insertion of a dummy read before the first actual display data read. This is shown in Figure 8.

Figure 8: Display data read back procedure - insertion of dummy read

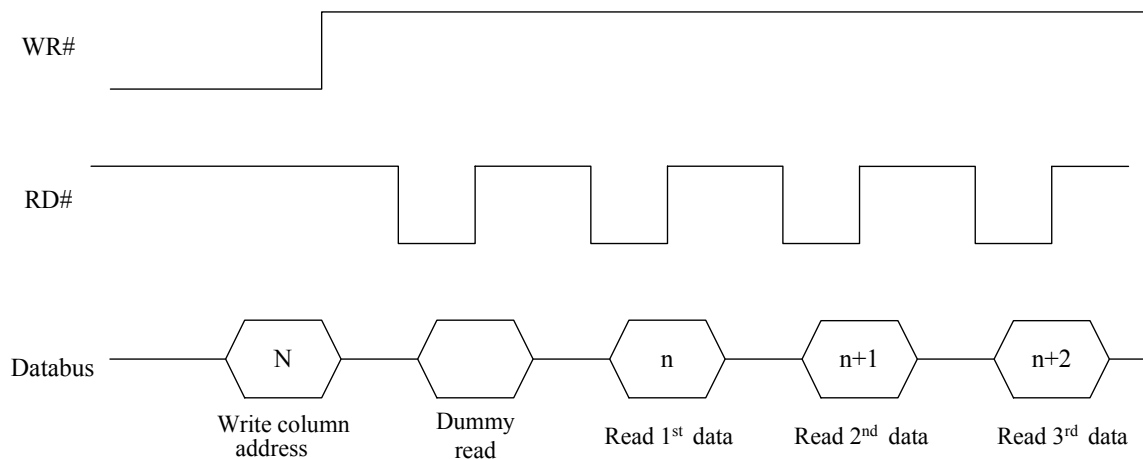

8.1.3 MPU Serial Interface

The serial interface consists of serial clock SCLK, serial data SDIN, D/C#, CS#. In SPI mode, D0 acts as SCLK, D1 acts as SDIN. For the unused data pins, D2 should be left open. The pins from D3 to D7, E and R/W# can be connected to an external ground.

Table 10: Control pins of Serial interface

Function	E	R/W#	CS#	D/C#
Write command	Tie LOW	Tie LOW	L	L
Write data	Tie LOW	Tie LOW	L	H

SDIN is shifted into an 8-bit shift register on every rising edge of SCLK in the order of D7, D6, ... D0. D/C# is sampled on every eighth clock and the data byte in the shift register is written to the Graphic Display Data RAM (GDDRAM) or command register in the same clock.

Under serial mode, only write operations are allowed.

Figure 9: Display data write procedure in SPI mode

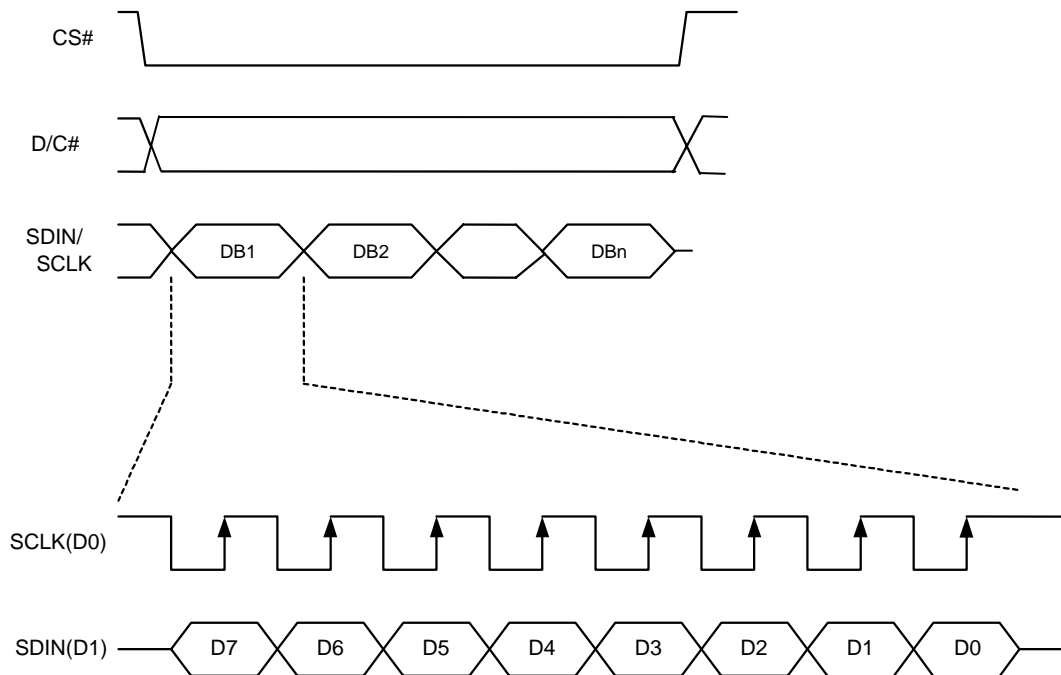

8.2 Segment Drivers/Common Drivers

Segment drivers have 128 current sources to drive OLED panel. The driving current can be adjusted from 0 to 300uA with 7 bits, 128 steps. Common drivers generate voltage scanning pulses. The block diagrams and waveforms of the segment and common driver are shown as follow.

Figure 10 : Segment and Common Driver Block Diagram

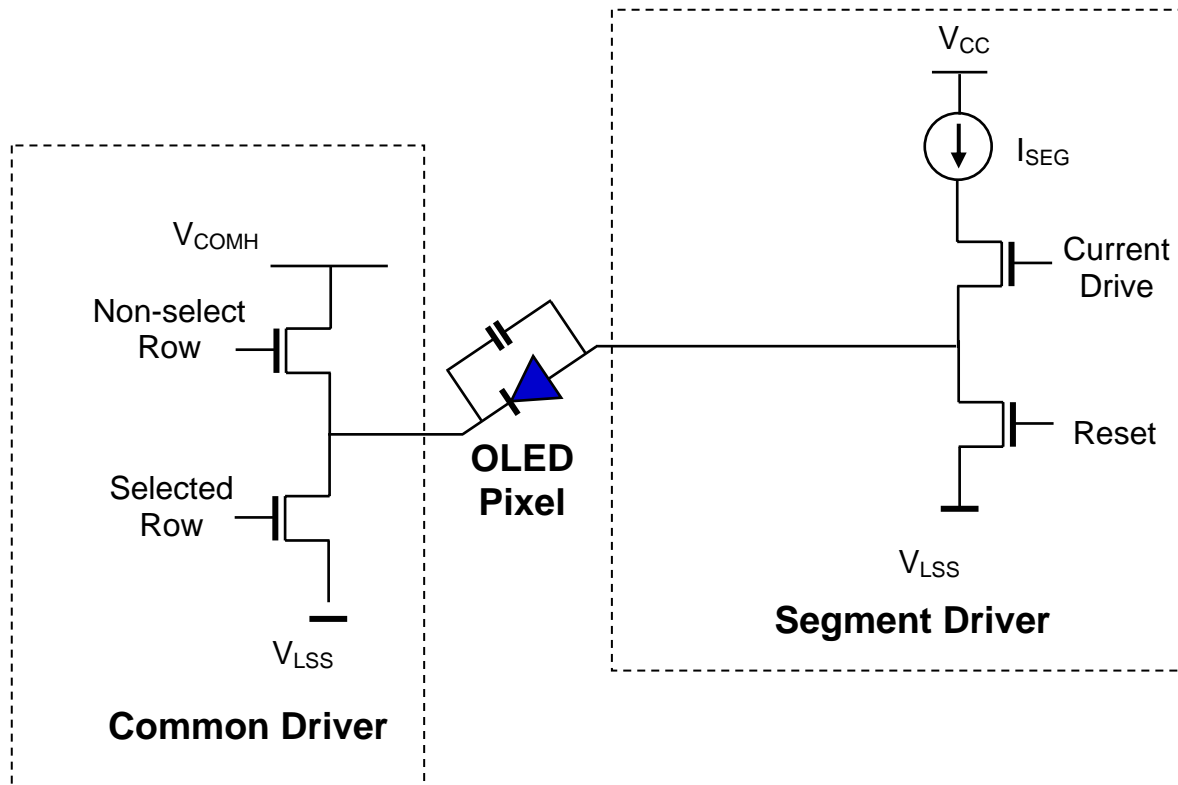

The commons are scanned sequentially, row by row. If a row is not selected, all the pixels on the row are in reverse bias by driving those commons to voltage V_{COMH} as shown in Figure 11.

In the scanned row, the pixels on the row will be turned ON or OFF by sending the corresponding data signal to the segment pins. If the pixel is turned OFF, the segment current is kept at 0. On the other hand, the segment drives to I_{SEG} when the pixel is turned ON.

Figure 11 : Segment and Common Driver Signal Waveform

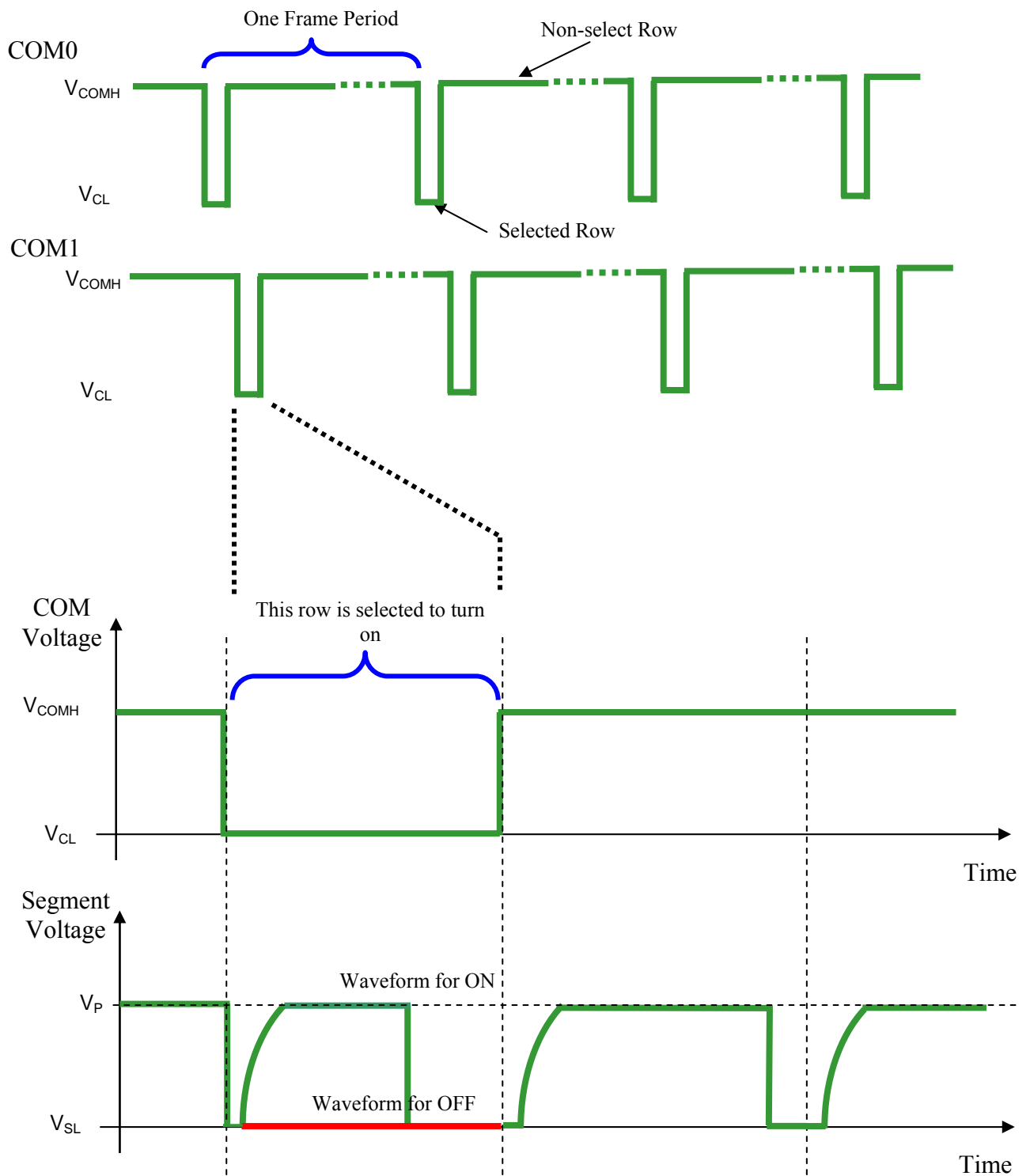

There are three phases to driving an OLED a pixel. In phase 1, the pixel is reset by the segment driver to V_{SS} in order to discharge the previous data charge stored in the parasitic capacitance along the segment electrode. The period of phase 1 can be programmed by command B1h A[3:0] from 1 to 15 DCLK. An OLED panel with larger capacitance requires a longer period for discharging.

In phase 2, pre-charge is performed. The pixel is driven to attain the corresponding voltage level V_P from V_{SS} . The amplitude of V_P can be programmed by the command BCh. The period of phase 2 can be programmed in length from 1 to 15 DCLK by command B1h A[7:4]. If the capacitance value of the pixel of OLED panel is larger, a longer period is required to charge up the capacitor to reach the desired voltage.

Last phase (phase 3 is current drive stage. The current source in the segment driver delivers constant current to the pixel. The driver IC employs PWM (Pulse Width Modulation) method to control the gray scale of each pixel individually. The wider pulse widths in the current drive stage results in brighter pixels and vice versa. This is shown in the following figure.

Figure 12 : Gray Scale Control by PWM in Segment

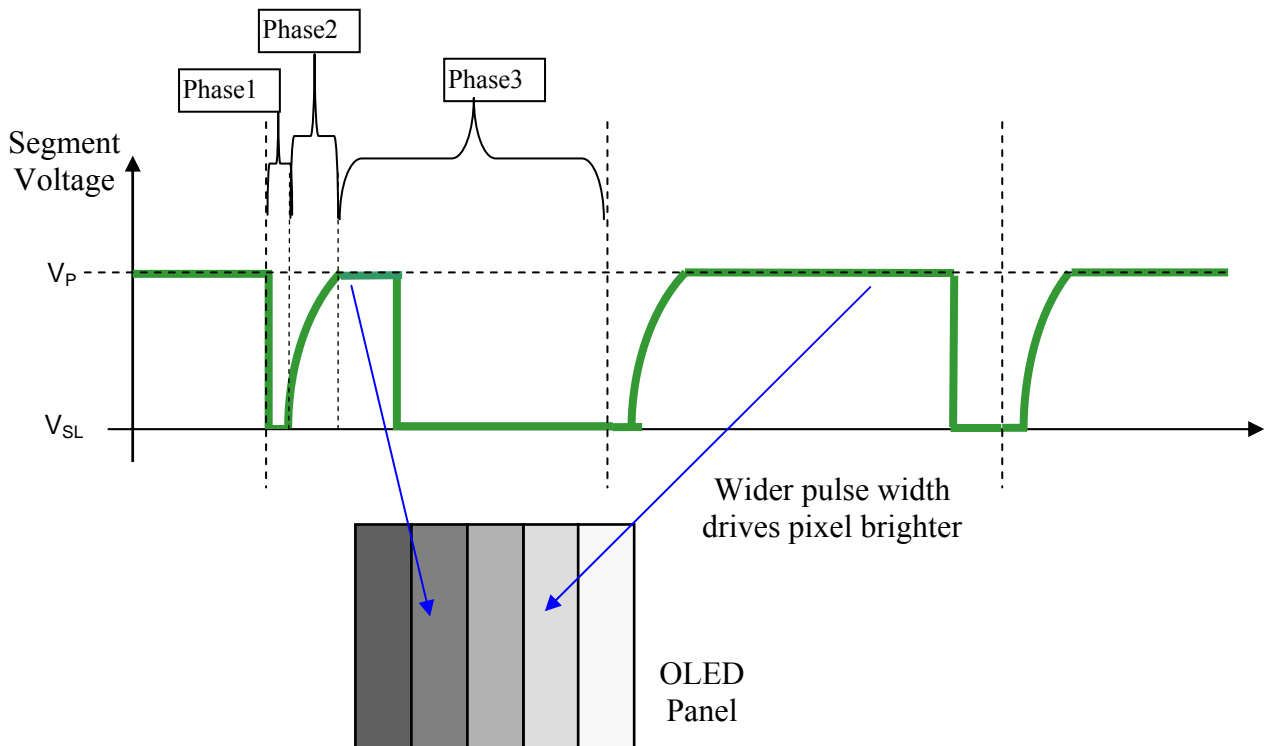

After finishing phase 3, the driver IC will go back to phase 1 to display the next row image data. This three-step cycle is run continuously to refresh image display on OLED panel.

The pulse width, which is counted from Phase 2 to Phase 3, is defined by command B8h “Set Gray Scale Table”. In the table, the gray scale is defined in incremental way, with reference to the length of previous table entry.

8.3 Oscillator Circuit and Display Time Generator

This module is an On-Chip low power RC oscillator circuitry. The operation clock (CLK) can be generated either from internal oscillator or external source CL pin. This selection is done by CLS pin. If CLS pin is pulled HIGH, internal oscillator is chosen and CL should be left open. Pulling CLS pin LOW disables internal oscillator and external clock must be connected to CL pins for proper operation. When the internal oscillator is selected, its output frequency F_{OSC} can be changed by command B3h, please refer to Table 18.

Figure 13 : Oscillator Circuit

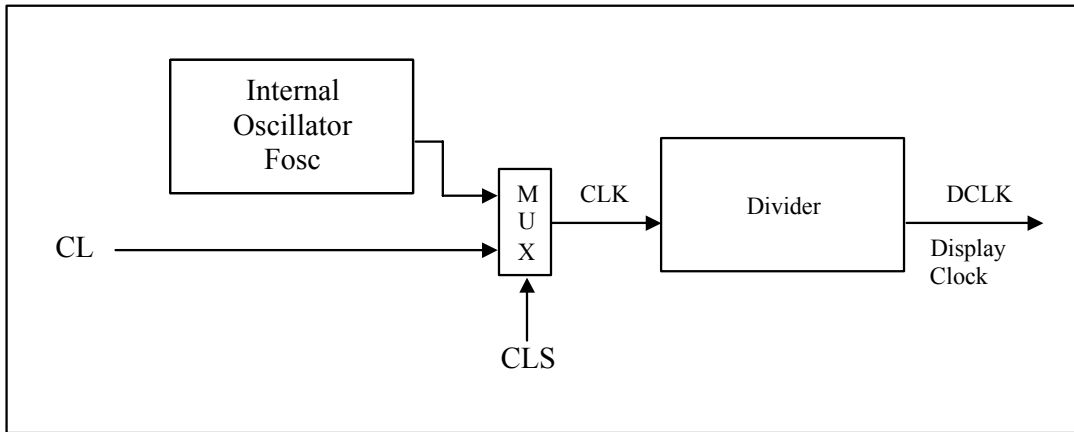

The display clock (DCLK) for the Display Timing Generator is derived from CLK. The division factor “D” can be programmed from 1 to 16 by command B3h

$$DCLK = F_{OSC} / D$$

The frame frequency of display is determined by the following formula.

$$F_{FRM} = \frac{F_{osc}}{D \times K \times \text{No. of Mux}}$$

where

- D stands for clock divide ratio. It is set by command B3h A[3:0]. The divide ratio has the range from 1 to 16.
- K is row period. It is configured by command B2h. This value should comply with following condition.

$$K \geq \text{Phase 1} + \text{Phase 2} + \text{Phase 3} + \text{GS15}$$

- Number of multiplex ratio is set by command A8h. The power ON reset value is 4Fh.
- F_{OSC} is the oscillator frequency. It can be changed by command B3h A[7:4]. The higher the register setting results in faster frequency.

If the frame frequency is set too low, flickering may occur. On the other hand, higher frame frequency leads to higher power consumption on the whole system.

8.4 Command Decoder and Command Interface

This module determines whether the input data is interpreted as data or command. Data is interpreted based upon the input of the D/C# pin.

If D/C# pin is HIGH, the input at D_7 - D_0 is written to Graphic Display Data RAM (GDDRAM). If it is LOW, the input at D_7 - D_0 is interpreted as a Command which will be decoded and be written to the corresponding command register.

8.5 Reset Circuit

When RES# input is LOW, the chip is initialized with the following status:

1. Display is OFF
2. 128 x 80 Display Mode
3. Normal segment and display data column address and row address mapping (SEG0 mapped to address 00h and COM0 mapped to address 00h)
4. Shift register data clear in serial interface
5. Display start line is set at display RAM address 0
6. Column address counter is set at 0
7. Normal scan direction of the COM outputs
8. Contrast control register is set at 40h

8.6 Current Control and Voltage Control

This block is used to derive the incoming power sources into the different levels of internal use voltage and current.

- V_{DD} is an external voltage supply.
- V_{CC} is the most positive external voltage supply.
- V_{COMH} is the Common deselected level. It is internally regulated.
- V_{SS} is the ground path of the analog and panel current.
- I_{REF} is a reference current source for segment current drivers I_{SEG} .

Note that V_{REF} is reference voltage, which is used to derive driving voltage for segments and commons. The magnitude of I_{REF} is controlled by the value of resistor, which is connected between I_{REF} pin and V_{SS} as shown in Figure 14. It is recommended to set I_{REF} to $10\mu A \pm 2\mu A$ so as to achieve $I_{SEG} = 300\mu A$ at maximum contrast 127.

Figure 14: I_{REF} Current Setting by Resistor Value

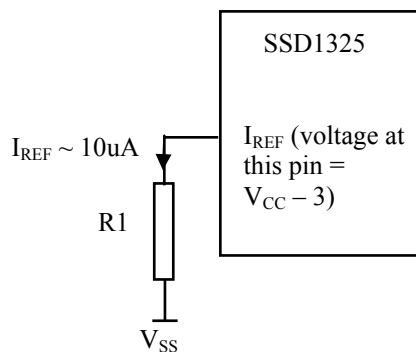

Since the voltage at I_{REF} pin is $V_{CC} - 3V$, the value of resistor $R1$ can be found as below.

$$R1 = (\text{Voltage at } I_{REF} - V_{SS}) / I_{REF} = (V_{CC} - 3) / 10\mu A \approx 910k\Omega \text{ for } V_{CC} = 12V.$$

8.7 Graphic Display Data RAM (GDDRAM)

The GDDRAM is a bit mapped static RAM holding the bit pattern to be displayed. The size of the RAM is 128x80x4 bits. For mechanical flexibility, re-mapping on both Segment and Common outputs can be selected by software. The GDDRAM address maps in

Table 11 to Table 15 show some examples on using the command “Set Re-map” A0h to re-map the GDDRAM. In the following tables, the lower nibble and higher nibble of D0, D1, D2 ... D5117, D5118, D5119 represent the 128x80 data bytes in the GDDRAM.

Table 11 shows the GDDRAM map under the following condition:

- Command “Set Re-map” A0h is set to:
 - Disable Column Address Re-map (A[0]=0)
 - Disable Nibble Re-map (A[1]=0)
 - Enable Horizontal Address Increment (A[2]=0)
 - Disable COM Re-map (A[4]=0)
- Display Start Line=00h
- Data byte sequence: D0, D1, D2 ... D5119

Table 11 : GDDRAM address map 1

		SEG0	SEG1	SEG2	SEG3		SEG124	SEG125	SEG126	SEG127	SEG Outputs Column Address (HEX)
		00		01			3E		3F		
COM0	00	D0[3:0]	D0[7:4]	D1[3:0]	D1[7:4]		D62[3:0]	D62[7:4]	D63[3:0]	D63[7:4]	
COM1	01	D64[3:0]	D64[7:4]	D65[3:0]	D65[7:4]		D126[3:0]	D126[7:4]	D127[3:0]	D127[7:4]	
COM78	4E	D4992[3:0]	D4992[7:4]	D4993[3:0]	D4993[7:4]		D5054[3:0]	D5054[7:4]	D5055[3:0]	D5055[7:4]	
COM79	4F	D5056[3:0]	D5056[7:4]	D5057[3:0]	D5057[7:4]		D5118[3:0]	D5118[7:4]	D5119[3:0]	D5119[7:4]	

COM Outputs Row Address (HEX)
(Display Startline=0)

Nibble re-map A[1]=0

Table 12 shows the GDDRAM map under the following condition:

- Command “Set Re-map” A0h is set to:
 - Disable Column Address Re-map (A[0]=0)
 - Disable Nibble Re-map (A[1]=0)
 - Enable Vertical Address Increment (A[2]=1)
 - Disable COM Re-map (A[4]=0)
- Display Start Line=00h
- Data byte sequence: D0, D1, D2 ... D5119

Table 12 : GDDRAM address map 2

		SEG0	SEG1	SEG2	SEG3		SEG124	SEG125	SEG126	SEG127	SEG Outputs Column Address (HEX)
		00		01			3E		3F		
COM0	00	D0[3:0]	D0[7:4]	D80[3:0]	D80[7:4]		D4960[3:0]	D4960[7:4]	D5040[3:0]	D5040[7:4]	
COM1	01	D1[3:0]	D1[7:4]	D81[3:0]	D81[7:4]		D4961[3:0]	D4961[7:4]	D5041[3:0]	D5041[7:4]	
COM78	4E	D78[3:0]	D78[7:4]	D158[3:0]	D158[7:4]		D5038[3:0]	D5038[7:4]	D5118[3:0]	D5118[7:4]	
COM79	4F	D79[3:0]	D79[7:4]	D159[3:0]	D159[7:4]		D5039[3:0]	D5039[7:4]	D5119[3:0]	D5119[7:4]	

COM Outputs Row Address (HEX)
(Display Startline=0)

Nibble re-map A[1]=0

Table 13 shows the GDDRAM map under the following condition:



- Command “Set Re-map” A0h is set to:
 - Enable Column Address Re-map (A[0]=1)
 - Enable Nibble Re-map (A[1]=1)
 - Enable Horizontal Address Increment (A[2]=0)
 - Disable COM Re-map (A[4]=0)
- Display Start Line=00h
- Data byte sequence: D0, D1, D2 ... D5119

Table 13 : GDDRAM address map 3

		SEG0	SEG1	SEG2	SEG3		SEG124	SEG125	SEG126	SEG127	SEG Outputs Column Address (HEX)
		3F		3E			01		00		
COM0	00	D63[7:4]	D63[3:0]	D62[7:4]	D62[3:0]		D1[7:4]	D1[3:0]	D0[7:4]	D0[3:0]	
COM1	01	D127[7:4]	D127[3:0]	D126[7:4]	D126[3:0]		D65[7:4]	D65[3:0]	D64[7:4]	D64[3:0]	
COM78	4E	D5055[7:4]	D5055[3:0]	D5054[7:4]	D5054[3:0]		D4993[7:4]	D4993[3:0]	D4992[7:4]	D4992[3:0]	
COM79	4F	D5119[7:4]	D5119[3:0]	D5118[7:4]	D5118[3:0]		D5057[7:4]	D5057[3:0]	D5056[7:4]	D5056[3:0]	
COM Outputs	Row Address (HEX)										

(Display Startline=0)

Nibble re-map A[1]=1

For vertical scrolling of the display, an internal register storing display start line can be set to control the portion of the RAM data to be mapped to the display.

Table 14 shows the example in which the display start line register is set to 10h with the following condition:

- Command “Set Re-map” A0h is set to:
 - Disable Column Address Re-map (A[0]=0)
 - Disable Nibble Re-map (A[1]=0)
 - Enable Horizontal Address Increment (A[2]=0)
 - Enable COM Re-map (A[4]=1)
- Display Start Line=10h (corresponds to COM15)
- Data byte sequence: D0, D1, D2 ... D5119

Table 14 : GDDRAM address map 4

		SEG0	SEG1	SEG2	SEG3		SEG124	SEG125	SEG126	SEG127	SEG Outputs Column Address (HEX)
		00		01			3E		3F		
COM15	0F	D0[3:0]	D0[7:4]	D1[3:0]	D1[7:4]		D62[3:0]	D62[7:4]	D63[3:0]	D63[7:4]	
COM14	0E	D64[3:0]	D64[7:4]	D65[3:0]	D65[7:4]		D126[3:0]	D126[7:4]	D127[3:0]	D127[7:4]	
COM17	11	D4992[3:0]	D4992[7:4]	D4993[3:0]	D4993[7:4]		D5054[3:0]	D5054[7:4]	D5055[3:0]	D5055[7:4]	
COM16	10	D5056[3:0]	D5056[7:4]	D5057[3:0]	D5057[7:4]		D5118[3:0]	D5118[7:4]	D5119[3:0]	D5119[7:4]	
COM Outputs	Row Address (HEX)										

(Display Startline=10H)

Nibble re-map A[1]=0

Table 15 shows the GDDRAM map under the following condition:

- Command “Set Re-map” A0h is set to:
 - Disable Column Address Re-map (A[0]=0)
 - Disable Nibble Re-map (A[1]=0)
 - Enable Horizontal Address Increment (A[2]=0)
 - Disable COM Re-map (A[4]=0)
- Display Start Line=00h
- Column Start Address=01h
- Column End Address=3Eh
- Row Start Address=01h
- Row End Address=4Eh
- Data byte sequence: D0, D1, D2 ... D4835

Table 15 : GDDRAM address map 5

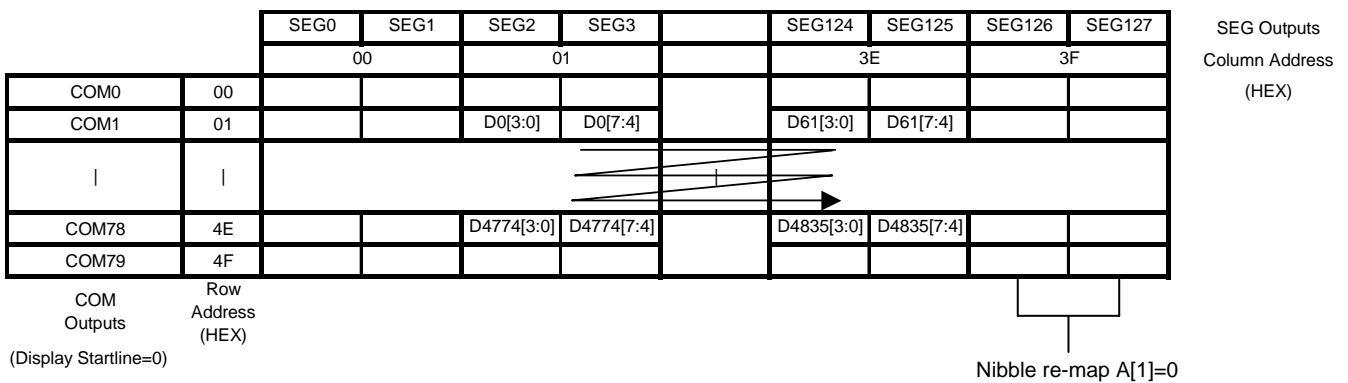

Note

- (1) Please refer to Table 18 for the details of setting command “Set Re-map”A0h.
- (2) The “Display Start Line” is set by the command “Set Display Start Line” A1h and please refer to Table 18 for the setting details
- (3) The “Column Start/End Address” is set by the command “Set Column Address” 15h and please refer to Table 18 for the setting details
- (4) The “Row Start/End Address” is set by the command “Set Row Address” 75h and please refer to Table 18 for the setting detail

8.8 Gray Scale Decoder

There are 16 gray levels from GS0 to GS15. The gray scale of the display is defined by the pulse width (PW) of current drive phase, GS0 has no pre-charge (phase 2) and no current drive (phase 3). Each L value represents an offset to the corresponding gray scale level. See below table and graphical representation:

Table16 : Gray scale pulse width set table

	Description	Number of DCLKs
L1	Set GS1 level Pulse Width	0-7
L2	Set GS2 level Pulse Width Offset	1-8
L3	Set GS3 level Pulse Width Offset	1-8
·	·	·
·	·	·
·	·	·
L13	Set GS13 level Pulse Width Offset	1-8
L14	Set GS14 level Pulse Width Offset	1-8
L15	Set GS15 level Pulse Width Offset	1-8

DCLK: Internal Display Clock. It is used for defining phase clock period.

Figure 15 : Gray scale pulse width set diagram

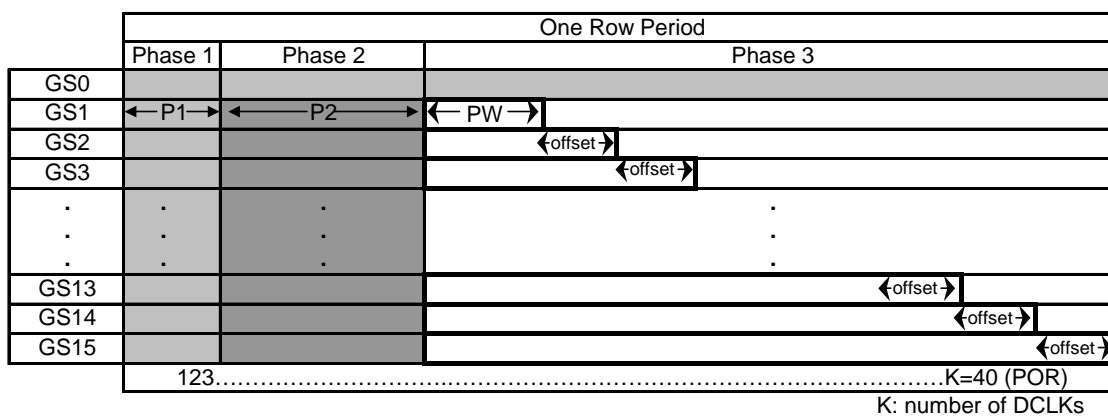

Table 17 : Gray scale pulse width default values

RESET	Result
L1=1	GS1 level Pulse width=1
L2=1	GS2 level Pulse width=3
L3=1	GS3 level Pulse width=5
L4=1	GS4 level Pulse width=7
L5=1	GS5 level Pulse width=9
L6=1	GS6 level Pulse width=11
L7=1	GS7 level Pulse width=13
L8=1	GS8 level Pulse width=15
L9=1	GS9 level Pulse width=17
L10=1	GS10 level Pulse width=19
L11=1	GS11 level Pulse width=21
L12=1	GS12 level Pulse width=23
L13=1	GS13 level Pulse width=25
L14=1	GS14 level Pulse width=27
L15=1	GS15 level Pulse width=29

8.9 Power ON and OFF sequence

The following figures illustrate the recommended power ON and power OFF sequence of SSD1325.

Power ON sequence:

1. Power ON V_{DD} .
2. After V_{DD} become stable, set RES# pin LOW (logic LOW) for at least 3 μ s (t_1)⁽⁴⁾ and then HIGH (logic HIGH).
3. After set RES# pin LOW (logic LOW), wait for at least 3 μ s (t_2). Then Power ON V_{CC} .⁽¹⁾
4. After V_{CC} become stable, send command AFh for display ON. SEG/COM will be ON after 100ms (t_{AF}).

Figure 16 : The Power ON sequence

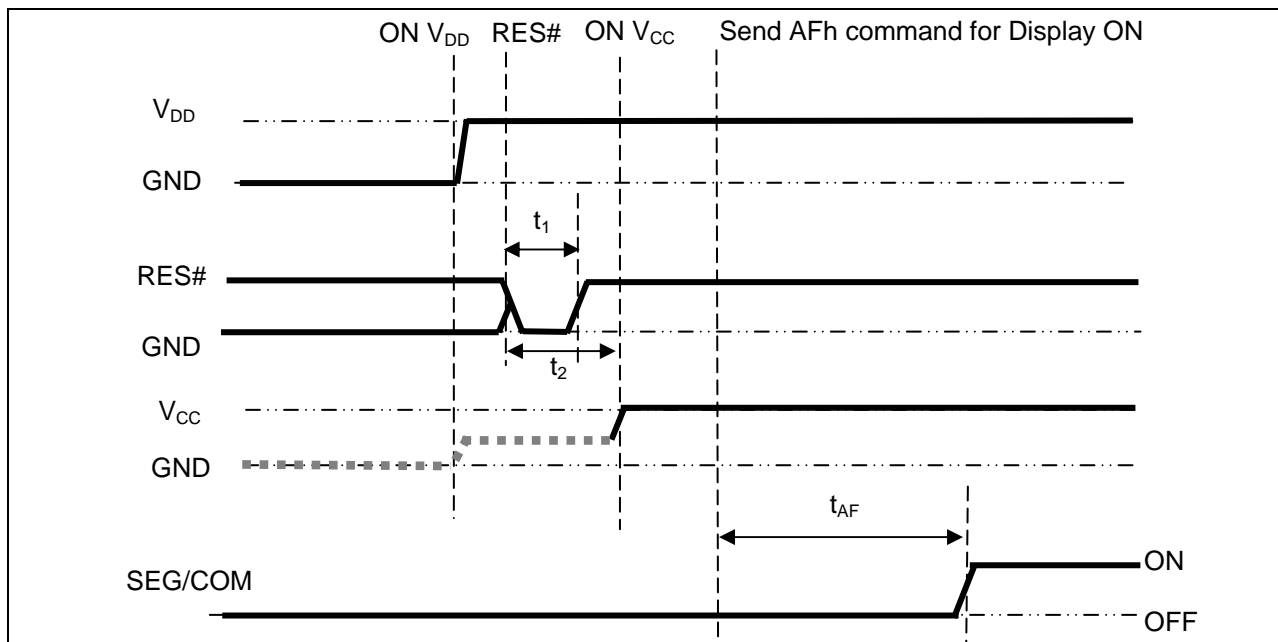

Power OFF sequence:

1. Send command AEh for display OFF.
2. Wait until panel discharges completely.
3. Power OFF V_{CC} .^{(1), (2), (3)}
4. Wait for t_{OFF} . Power OFF V_{DD} . (where Minimum $t_{OFF}=0ms$ ⁽⁵⁾ Typical $t_{OFF}=100ms$)

Figure 17 : The Power OFF sequence

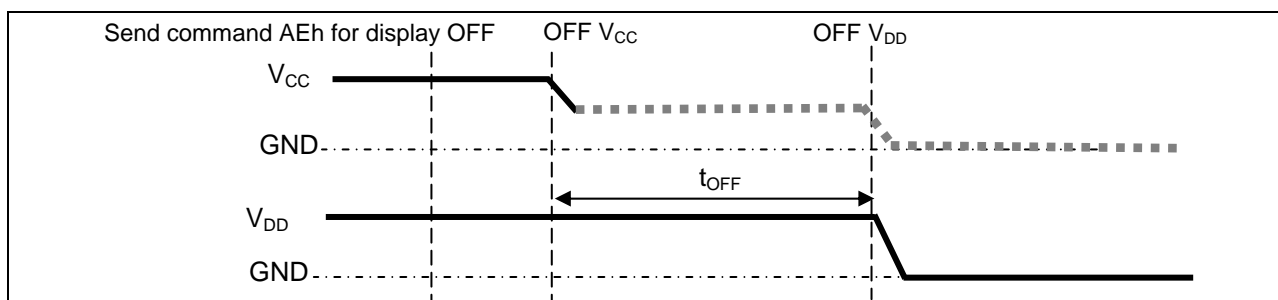

Note:

- (1) Since an ESD protection circuit is connected between V_{DD} and V_{CC} , V_{CC} becomes lower than V_{DD} whenever V_{DD} is ON and V_{CC} is OFF as shown in the dotted line of V_{CC} in Figure 16 and Figure 17.
- (2) V_{CC} should be kept float (disable) when it is OFF.
- (3) Power Pins (V_{DD} , V_{CC}) can never be pulled to ground under any circumstance.
- (4) The register values are reset after t_1 .
- (5) V_{DD} should not be Power OFF before V_{CC} Power OFF.

9 COMMAND TABLE

Table 18: Command Table

(D/C# = 0, R/W# (WR#) = 0, E (RD#) = 1) unless specific setting is stated

Fundamental Command Table											
D/C	Hex	D7	D6	D5	D4	D3	D2	D1	D0	Command	Description
0 0 0	15 A[5:0] B[5:0]	0 * *	0 * *	0 A ₅ B ₅	1 A ₄ B ₄	0 A ₃ B ₃	1 A ₂ B ₂	0 A ₁ B ₁	1 A ₀ B ₀	Set Column Address	Second command A[5:0] sets the column start address from 0-63, POR = 00h Third command B[5:0] sets the column end address from 0-63, RESET = 3Fh
0 0 0	75 A[6:0] B[6:0]	0 * *	1 A ₆ B ₆	1 A ₅ B ₅	1 A ₄ B ₄	0 A ₃ B ₃	1 A ₂ B ₂	0 A ₁ B ₁	1 A ₀ B ₀	Set Row address	Second command A[6:0] sets the row start address from 0-79, RESET = 00h Third command B[6:0] sets the row end address from 0-79, RESET = 4Fh
0 0	81 A[6:0]	1 *	0 A ₆	0 A ₅	0 A ₄	0 A ₃	0 A ₂	0 A ₁	1 A ₀	Set Contrast Current	Double byte command to select 1 out of 128 contrast steps. Contrast increases as level increase The level is set to 40h after RESET
0	84~86	1	0	0	0	0	1	X ₁	X ₀	Set Current Range	84h = Quarter Current Range (RESET) 85h = Half Current Range 86h = Full Current Range
0 0	A0 A[6:0]	1 *	0 A ₆	1 A ₅	0 A ₄	0 A ₃	0 A ₂	0 A ₁	0 A ₀	Set Re-map	A[0]=0, Disable Column Address Re-map (RESET) A[0]=1, Enable Column Address Re-map A[1]=0, Disable Nibble Re-map (RESET) A[1]=1, Enable Nibble Re-map A[2]=0, Horizontal Address Increment (RESET) A[2]=1, Vertical Address Increment A[4]=0, Disable COM Re-map disable (RESET) A[4]=1, Enable COM Re-map A[5]=0, Reserved (RESET) A[5]=1, Reserved A[6]=0, Disable COM Split Odd Even (RESET) A[6]=1, Enable COM Split Odd Even
0 0	A1 A[6:0]	1 *	0 A ₆	1 A ₅	0 A ₄	0 A ₃	0 A ₂	0 A ₁	1 A ₀	Set Display Start Line	Set display RAM display start line register from 0-79 Display start line register is reset to 00h after RESET
0 0	A2 A[6:0]	1 *	0 A ₆	1 A ₅	0 A ₄	0 A ₃	0 A ₂	1 A ₁	0 A ₀	Set Display Offset	Set vertical scroll by COM from 0-79 The value is reset to 00H after RESET

Fundamental Command Table											
D/C	Hex	D7	D6	D5	D4	D3	D2	D1	D0	Command	Description
0	A4~A7	1	0	1	0	0	X ₂	X ₁	X ₀	Set Display Mode	<p>A4h = Normal Display (RESET)</p> <p>A5h = Entire Display ON, all pixels turns ON in GS level 15</p> <p>A6h = Entire Display OFF, all pixels turns OFF</p> <p>A7h = Inverse Display</p>
0 0	A8 A[6:0]	1 *	0 A ₆	1 A ₅	0 A ₄	1 A ₃	0 A ₂	0 A ₁	0 A ₀	Set Multiplex Ratio	<p>The next command determines multiplex ratio N from 16MUX-80MUX,</p> <p>A[6:0] = 15 represents 16MUX A[6:0] = 16 represents 17MUX : A[6:0] = 78 represents 79MUX A[6:0] = 79 represents 80MUX</p>
0 0	AD A[1:0]	1 *	0 *	1 *	0 *	1 *	1 *	0 1	1 A ₀	Set Master Configuration	<p>A[0] = 0, Select external V_{CC} supply A[0] = 1, Reserved (RESET)</p> <p>Note ⁽¹⁾ Bit A[0] must be set to 0b after RESET. ⁽²⁾ The setting will be activated after issuing Set Display ON command (AFh)</p>
0	AE	1	0	1	0	1	1	1	0	Set Display ON	A Eh = Display OFF (Sleep mode) (RESET)
0	AF	1	0	1	0	1	1	1	1	Set Display OFF	AFh = Display ON
0 0	B0 A[5:0]	1 *	0 *	1 A ₅	1 A ₄	0 A ₃	0 A ₂	0 A ₁	0 A ₀	Set Pre-charge Compensation Enable	<p>A[5:0] = 08h (RESET)</p> <p>A[5:0] = 28h, Enable pre-charge compensation</p>
0 0 0	B1 A[3:0] A[7:4]	1 * A ₇	0 * A ₆	1 * A ₅	1 * A ₄	0 A ₃	0 A ₂	0 A ₁	1 A ₀ *	Set Phase Length	<p>A[3:0] = P1, phase 1 period of 1-15 DCLKs, RESET = 3DCLKS = 3h</p> <p>A[7:4] = P2, phase 2 period of 1-15 DCLKs, RESET = 5DCLKS = 5h</p> <p>Note ⁽¹⁾ 0 DCLK is invalid in phase 1 & phase 2</p>
0 0	B2 A[7:0]	1 A ₇	0 A ₆	1 A ₅	1 A ₄	0 A ₃	0 A ₂	1 A ₁	0 A ₀	Set Row Period (set frame frequency)	<p>The next command sets the number of DCLKs, K, per row between 2-158 DCLKS RESET = 37DCLKS = 25h The K value should be set as K = P1+P2+GS15 pulse width (RESET: 3+5+29DCLKS)</p>

Fundamental Command Table												
D/C	Hex	D7	D6	D5	D4	D3	D2	D1	D0	Command	Description	
0 0 0	B3 A[3:0] A[7:4]	1 * A ₇	0 * A ₆	1 * A ₅	1 * A ₄	0 A ₃	0 A ₂	1 A ₁	1 A ₀	Set Display Clock Divide Ratio / Oscillator Frequency	The lower nibble (A[3:0]) of the next command defines the divide ratio (D) of display clock (DCLK) Divide ratio (D)=A[3:0]+1 (A[3:0]RESET is 0001b, i.e. divide ratio (D) = 2) The higher nibble (A[7:4]) of the next command sets the Oscillator Frequency Oscillator Frequency increases with the value of A[7:4] and vice versa Range: 0000b~1111b RESET= 0100b represents 655KHz, typical step value: 5% of previous value	
0 0	B4 A[2:0]	1 *	0 *	1 *	1 *	0 *	1 A ₂	0 A ₁	0 A ₀	Set Pre-charge Compensation Level	A[2:0] = 0 (RESET) A[2:0] = 3h, Recommended level	
0 0 0 0 0 0 0 0 0 0 0 0 0 0 0 0 0 0	B8 A[2:0] B[2:0] B[6:4] C[2:0] C[6:4] D[2:0] D[6:4] E[2:0] E[6:4] F[2:0] F[6:4] G[2:0] G[6:4] H[2:0] H[6:4]	1 * * * * * * * * * * * * * * * * *	0 * * B ₆ * C ₆ * D ₆ * E ₆ * F ₆ * G ₆ * H ₆	1 * * B ₅ * C ₅ * D ₅ * E ₅ * F ₅ * G ₅ * H ₅	1 * * B ₄ * C ₄ * D ₄ * E ₄ * F ₄ * G ₄ * H ₄	1 * * * * * * * * * * * * * * * * *	0 A ₂	0 B ₂	0 B ₁	0 B ₀	Set Gray Scale Table	The next eight bytes of command set the gray scale level of GS1-15 as below: A[2:0] = Gray scale level of GS1, RESET=1 B[2:0] = Gray scale level of GS2, RESET=1 B[6:4] = Gray scale level of GS3, RESET=1 C[2:0] = Gray scale level of GS4, RESET=1 C[6:4] = Gray scale level of GS5, RESET=1 D[2:0] = Gray scale level of GS6, RESET=1 D[6:4] = Gray scale level of GS7, RESET=1 E[2:0] = Gray scale level of GS8, RESET=1 E[6:4] = Gray scale level of GS9, RESET=1 F[2:0] = Gray scale level of GS10, RESET=1 F[6:4] = Gray scale level of GS11, RESET=1 G[2:0] = Gray scale level of GS12, RESET=1 G[6:4] = Gray scale level of GS13, RESET=1 H[2:0] = Gray scale level of GS14, RESET=1 H[6:4] = Gray scale level of GS15, RESET=1
0 0	BC A[7:0]	1 A ₇	0 A ₆	1 A ₅	1 A ₄	1 A ₃	1 A ₂	0 A ₁	0 A ₀	Set Precharge Voltage	Second command A[7:0] sets the precharge voltage level, A[7:0] 1xxxxxxx connects to V _{COMH} 001xxxxx 1.0 * V _{REF} 00000000 0.51* V _{REF} 00000001 0.52* V _{REF} 00011000 0.75* V _{REF} (RESET) 00011111 0.84* V _{REF}	
0 0	BE A[4:0]	1 *	0 *	1 0	1 A ₄	1 A ₃	1 A ₂	1 A ₁	0 A ₀	Set V _{COMH} Voltage	Second command A[4:0] sets the V _{COMH} voltage level , A[4:0] 00000 0.51*V _{REF} 00001 0.52* V _{REF} 10001 0.68* V _{REF} (RESET) 11101 0.81* V _{REF} 11110 0.82* V _{REF} 11111 0.84* V _{REF}	

Fundamental Command Table											
D/C	Hex	D7	D6	D5	D4	D3	D2	D1	D0	Command	Description
0 0	BF A[3:0]	1 *	0 *	1 *	1 *	1 A ₃	1 A ₂	1 A ₁	1 A ₀	Set Segment Low Voltage (VSL)	Second command A[3:0] sets the VSL voltage as follow: A[3:0] = 0010 kept VSL pin NC A[3:0] = 1110 (RESET) connect a capacitor between VSL pin and V _{SS}
0	E3	1	1	1	0	0	0	1	1	NOF	Command for No Operation

Table 19: Graphic acceleration command

Set (GAC) (D/C# = 0, R/W#(WR#)= 0, E(RD#) = 1) unless specific setting is stated

Graphic acceleration command											
D/C#	Hex	D7	D6	D5	D4	D3	D2	D1	D0	Command	Description
0 0	23 A[4:0]	0 *	0 *	1 *	0 A ₄	0 *	0 *	1 A ₁	1 A ₀	Graphic Acceleration Command Options	A[0] = 0b: Disable Fill rectangle A[0] = 1b: Enable Fill rectangle (RESET) A[1] = 0b: Disable x-wrap(RESET) A[1] = 1b: Enable wrap around in x-direction during copying and scrolling A[4] = 0b: Disable reverse copy (RESET) A[4] = 1b: Enable reverse during copying.
0 0 0 0 0 0	24 A[5:0] B[6:0] C[5:0] D[6:0] E[7:0]	0 * * * * E ₇	0 * B ₆ * D ₆ E ₆	1 A ₅ B ₅ C ₅ D ₅ E ₅	0 A ₄ B ₄ C ₄ D ₄ E ₄	0 A ₃ B ₃ C ₃ D ₃ E ₃	1 A ₂ B ₂ C ₂ D ₂ E ₂	0 A ₁ B ₁ C ₁ D ₁ E ₁	0 A ₀ B ₀ C ₀ D ₀ E ₀	Draw Rectangle	A[5:0]: Column Address of Start B[6:0]: Row Address of Start C[5:0]: Column Address of End D[6:0]: Row Address of End E[7:0]: Set Gray scale pattern E[7:0] This byte is divided into two nibbles. The most significant 4 bits represent the gray scale level of the left pixel of each group. The least significant 4 bits represent the gray scale level of the right pixel of each group. Please refer to Figure 31 for the gray scale pattern setting examples. Note: (1) 0 ≤ A < C ≤ 63 (2) 0 ≤ B < D ≤ 79
0 0 0 0 0 0 0	25 A[5:0] B[6:0] C[5:0] D[6:0] E[5:0] F[6:0]	0 * * * * * *	0 * B ₆ * D ₆ * F ₆	1 A ₅ B ₅ C ₅ D ₅ E ₅ F ₅	0 A ₄ B ₄ C ₄ D ₄ E ₄ F ₄	0 A ₃ B ₃ C ₃ D ₃ E ₃ F ₃	1 A ₂ B ₂ C ₂ D ₂ E ₂ F ₂	0 A ₁ B ₁ C ₁ D ₁ E ₁ F ₁	1 A ₀ B ₀ C ₀ D ₀ E ₀ F ₀	Copy	A[5:0]: Column Address of Start B[6:0]: Row Address of Start C[5:0]: Column Address of End D[6:0]: Row Address of End

Graphic acceleration command											
D/C#	Hex	D7	D6	D5	D4	D3	D2	D2	D0	Command	Description
											E[5:0]: Column Address of New Start F[6:0]: Row Address of New Start Note: (1) $0 \leq A < C \leq 63$ (2) $0 \leq B < D \leq 79$ (3) $0 \leq E \leq 63$ (4) $0 \leq F \leq 79$
0 0 0 0	26 A[5:0] B[6:0] C[1:0]	0 * * *	0 * B ₆ *	1 A ₅ B ₅ *	0 A ₄ B ₄ *	0 A ₃ B ₃ *	1 A ₂ B ₂ *	1 A ₁ B ₁ *	0 A ₀ B ₀ C ₁	Horizontal Scroll	A[5:0]: 1~63 horizontal offset in number of 2~127 column 0 no horizontal scroll B[6:0]: 2~80 number of rows to be H-scrolled C[1:0]: scrolling time interval 00b 12 frames 01b 64 frames 10b 128 frames 11b 256 frames Note: (1) Scrolling operates during display ON. (2) The parameters should not be changed after scrolling is activated
0	2E	0	0	1	0	1	1	1	0	Stop Moving	This command deactivates the scrolling action. Note (1) After sending 2Eh command to deactivate the scrolling action, the ram data needs to be rewritten.
0	2F	0	0	1	0	1	1	1	1	Start Moving	This command activates the scrolling function according to the setting done by Horizontal Scroll command 26h. Note (1) The “wrap around in x-direction” function must be enabled before scrolling start. i.e. Bit A{1} of command 23h must be set to 1b before issuing 2F command.

Table 20: Read Command Table

(D/C#=0, R/W# (WR#)=1, E (RD#)=1 for 6800 or E (RD#)=0 for 8080)

D ₇ D ₆ D ₅ D ₄ D ₃ D ₂ D ₁ D ₀	Status Register Read	D7 = 0:reserved D7 = 1:reserved D6 = 0:indicates the display is ON D6 = 1:indicated the display is OFF D5 = 0:reserved D5 = 1:reserved D4 = 0:reserved D4 = 1:reserved
--	----------------------	---

Note

(1) Patterns other than that given in Command Table are prohibited to enter to the chip as a command; Otherwise, unexpected result will occur

9.1 Data Read / Write

To read data from the GDDRAM, input HIGH to R/W# (WR#) pin and D/C# pin for 6800-series parallel mode, LOW to E (RD#) pin and HIGH to D/C# pin for 8080-series parallel mode.

In horizontal address increment mode, GDDRAM column address pointer will be increased by one automatically after each data read. In vertical address increment mode, GDDRAM row address pointer will be increased by one automatically after each data read.

Also, a dummy read is required before the first data read. See Figure 5 and Figure 8 in Functional Description.

To write data to the GDDRAM, input LOW to R/W#(WR#) pin and HIGH to D/C# pin for 6800-series parallel mode and 8080-series parallel mode. For serial interface mode, it is always in write mode. In horizontal address increment mode, GDDRAM column address pointer will be increased by one automatically after each data write. In vertical address increment mode, GDDRAM row address pointer will be increased by one automatically after each data write.

It should be noted that, in horizontal address increment mode, the row address pointer would be increased by one automatically if the column address pointer wraps around. In vertical address increment mode, the column address pointer will be increased by one automatically if the row address pointer wraps around.

Table 21: Address Increment Table (Automatic)

D/C#	R/W# (WR#)	Comment	Address Increment
0	0	Write Command	No
0	1	Read Status	No
1	0	Write Data	Yes
1	1	Read Data	Yes

10 COMMAND DESCRIPTIONS

10.1 Fundamental command description

10.1.1 Set Column Address (15h)

This triple byte command specifies column start address and end address of the display data RAM. This command also sets the column address pointer to column start address. This pointer is used to define the current read/write column address in graphic display data RAM. If horizontal address increment mode is enabled by command A0h, after finishing read/write one column data, it is incremented automatically to the next column address. Whenever the column address pointer finishes accessing the end column address, it is reset back to start column address and the row address is incremented to the next row.

10.1.2 Set Row Address (75h)

This triple byte command specifies row start address and end address of the display data RAM. This command also sets the row address pointer to row start address. This pointer is used to define the current read/write row address in graphic display data RAM. If vertical address increment mode is enabled by command A0h, after finishing read/write one row data, it is incremented automatically to the next row address. Whenever the row address pointer finishes accessing the end row address, it is reset back to start row address.

The diagram below shows the way of column and row address pointer movement through the example: column start address is set to 2 and column end address is set to 61, row start address is set to 1 and row end address is set to 78; horizontal address increment mode is enabled by command A0h. In this case, the graphic display data RAM column accessible range is from column 2 to column 61 and from row 1 to row 78 only. In addition, the column address pointer is set to 2 and row address pointer is set to 1. After finishing read/write one pixel of data, the column address is increased automatically by 1 to access the next RAM location for next read/write operation (*solid line in Figure 18*). Whenever the column address pointer finishes accessing the end column 61, it is reset back to column 2 and row address is automatically increased by 1 (*solid line in Figure 18*). While the end row 78 and end column 61 RAM location is accessed, the row address is reset back to 1 and the column address is reset back to 2 (*dotted line in Figure 18*).

Figure 18 : Example of Column and Row Address Pointer Movement

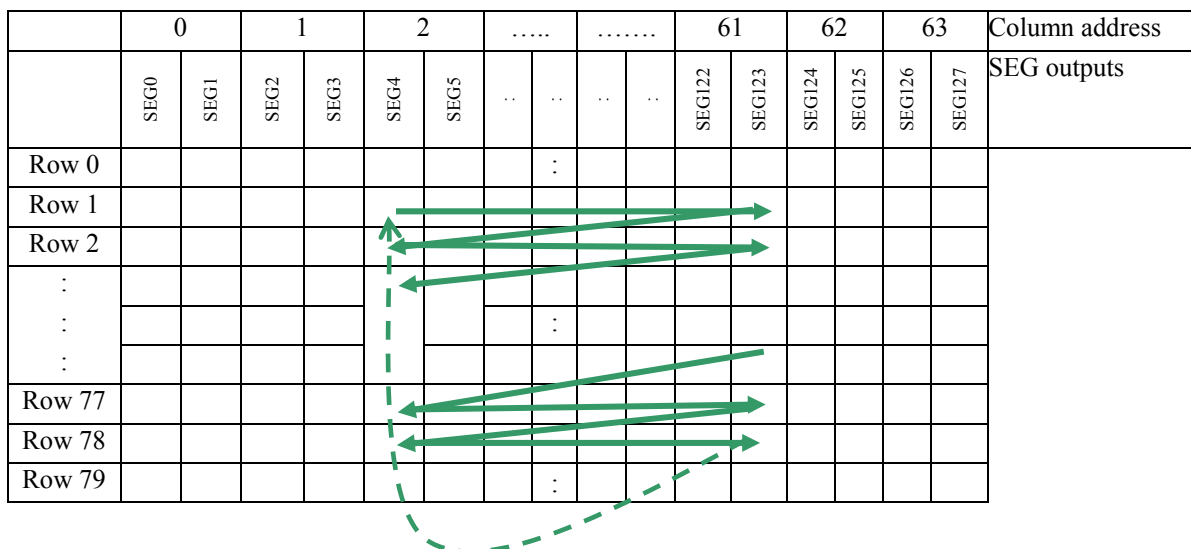

10.1.3 Set Contrast Current (81h)

This command is to set Contrast Setting of the display. The chip has 128 contrast steps from 00H to 7FH. The segment output current increases with the increase of contrast step. See Figure 19 below.

Figure 19 : Segment current vs Contrast setting

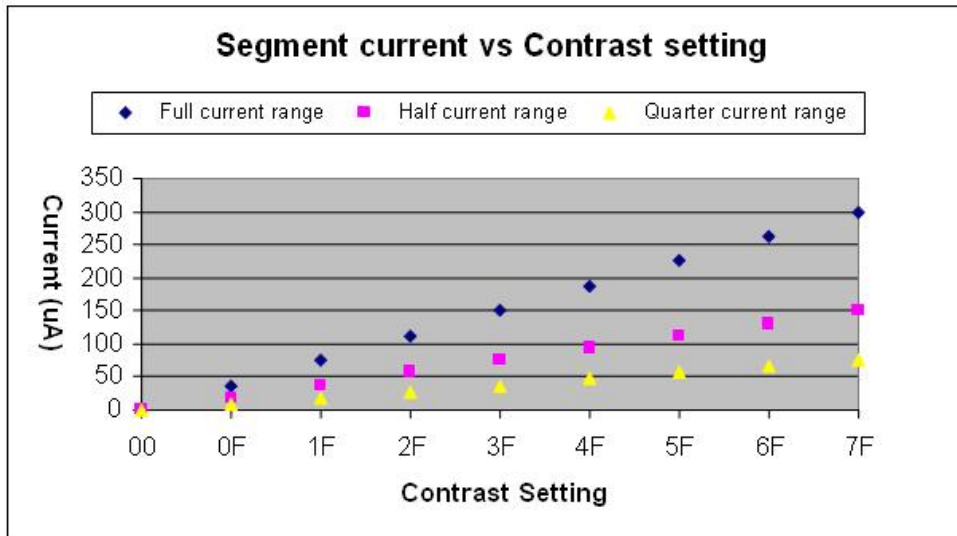

10.1.4 Set Current Range (84h, 85h, 87h)

This command is used to select quarter range or half range or full range current mode. With the same contrast level, quarter range mode will give a quarter of the current output of the full range mode. Similar to half range current mode, it will give a half of the current output of the full range mode. See Figure 19. In RESET, quarter range current mode is default.

10.1.5 Set Re-map (A0h)

This double command has multiple configurations and each bit setting is described as follows:

- Column Address Remapping (A[0])
This bit is made for increase the flexibility layout of segment signals in OLED module with segment arranged from left to right (when A[0] is set to 0) or from right to left (when A[0] is set to 1).
- Nibble Remapping (A[1])
When A[1] is set to 1, the two nibbles of the data bus for RAM access are re-mapped, such that (D7, D6, D5, D4, D3, D2, D1, D0) acts like (D3, D2, D1, D0, D7, D6, D5, D4).
If this feature works together with Column Address Re-map, it would produce an effect of flipping the outputs from SEG0~127 to SEG127~SEG0 as show in Table 13.
- Address increment mode (A[2])
When A[2] is set to 0, the driver is set as horizontal address increment mode. After the display RAM is read / written, the column address pointer is increased automatically by 1. If the column address pointer reaches column end address, the column address pointer is reset to column start address and row address pointer is increased by 1. The sequence of movement of the row and column address point for horizontal address increment mode is shown in Figure 20

Figure 20 : Address Pointer Movement of Horizontal Address Increment Mode

	0	1	62	63	Column address
Row 0	→					
Row 1	←					
⋮	⋮	⋮	⋮	⋮	⋮	
Row 78	←					
Row 79	→					

When A[2] is set to 1, the driver is set to vertical address increment mode. After the display RAM is read / written, the row address pointer is increased automatically by 1. If the row address pointer reaches the row end address, the row address pointer is reset to row start address and column address pointer is increased by 1. The sequence of movement of the row and column address point for vertical address increment mode is shown in Figure 21.

Figure 21: Address Pointer Movement of Vertical Address Increment Mode

	0	1	62	63	Column address
Row 0	↓	↗	↗	↗	↗	
Row 1		↓	↗	↗	↗	
⋮			⋮			
Row 126	↓	↗	↗	↗	↗	
Row 127		↓	↗	↗	↗	

- **COM Remapping (A[4])**
 This bit defines the scanning direction of the common for flexible layout of common signals in OLED module either from up to down (when A[4] is set to 0) or from bottom to up (when A[4] is set to 1). Table 14 shows an example of the using the COM Remapping to perform vertical scrolling.

- Splitting of Odd / Even COM Signals (A[6])
This bit is made to match the COM layout connection on the panel.

When A[6] is set to 0, no splitting odd / even of the COM signal is performed, output pin assignment sequence is shown as below (for 80MUX ratio):

Figure 22: Output pin assignment when command A0h bit A[6]=0.

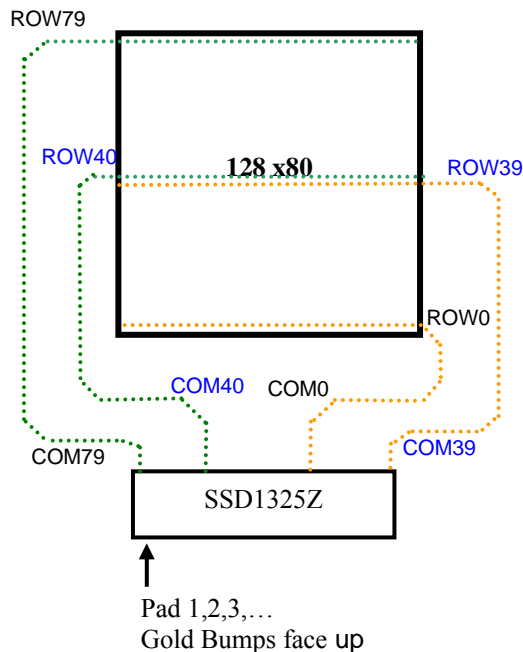

Output Pin Connection	
SSD1325Z	Panel
COM0	ROW0
COM1	ROW1
COM2	ROW2
COM3	ROW3
:	:
COM39	ROW39
COM40	ROW40
:	:
COM77	ROW77
COM78	ROW78
COM79	ROW79

When A[6] is set to 1, splitting odd / even of the COM signal is performed, output pin assignment sequence is shown as below (for 128MUX ratio):

Figure 23 : Output pin assignment when command A0h bit A[6]=1.

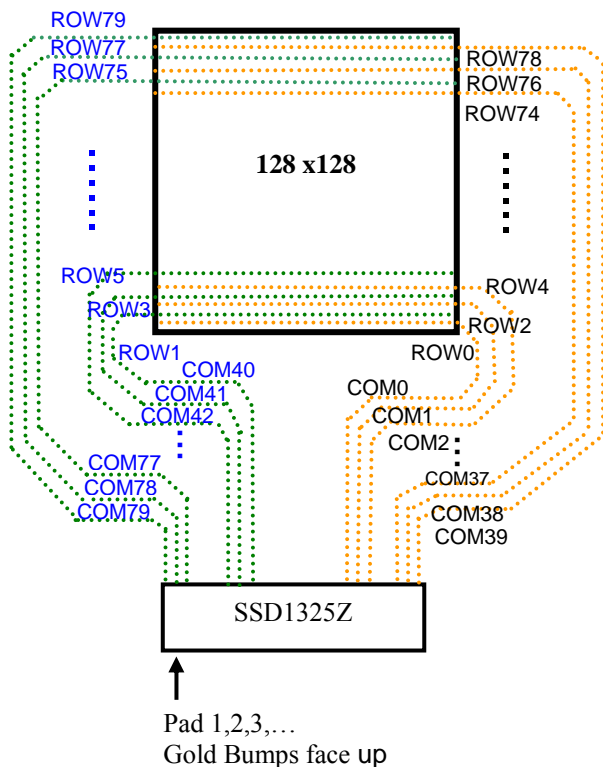





Output Pin Connection	
SSD1325Z	Panel
COM0	ROW0 (Even)
COM1	ROW2
COM2	ROW4
:	:
COM37	ROW74
COM38	ROW76
COM39	ROW78
COM40	ROW1 (Odd)
COM41	ROW3
COM42	ROW5
:	:
COM77	ROW75
COM78	ROW77
COM79	ROW79

10.1.6 Set Display Start Line (A1h)

This double byte command is to set Display Start Line register for determining the starting address of display RAM to be displayed by selecting a value from 0 to 79. Figure 24 shows an example using this command of this command when MUX ratio= 80 and MUX ratio= 54 and Display Start Line = 28. In there, “ROW” means the graphic display data RAM row.





Figure 24: Example of Set Display Start Line with no Remapping

	MUX ratio (A8h) = 80	MUX ratio (A8h) = 80	MUX ratio (A8h) = 54	MUX ratio (A8h) = 54
COM Pin	Display Start Line (A1h) = 0	Display Start Line (A1h) = 28	Display Start Line (A1h) = 0	Display Start Line (A1h) = 28
COM0	ROW0	ROW28	ROW0	ROW28
COM1	ROW1	ROW29	ROW1	ROW29
COM2	ROW2	ROW30	ROW2	ROW30
COM3	ROW3	ROW31	ROW3	ROW31
:	:	:	:	:
:	:	:	:	:
COM23	ROW23	ROW51	ROW23	ROW51
COM24	ROW24	ROW52	ROW24	ROW52
COM25	ROW25	ROW53	ROW25	ROW53
COM26	ROW26	ROW54	ROW26	ROW54
:	:	:	:	:
:	:	:	:	:
COM49	ROW50	ROW77	ROW50	ROW77
COM51	ROW51	ROW78	ROW51	ROW78
COM52	ROW52	ROW79	ROW52	ROW79
COM53	ROW53	ROW0	ROW53	ROW0
COM54	ROW54	ROW1	-	-
COM55	ROW55	ROW2	-	-
:	:	:	:	:
:	:	:	:	:
COM76	ROW76	ROW24	-	-
COM77	ROW77	ROW25	-	-
COM78	ROW78	ROW26	-	-
COM79	ROW79	ROW27	-	-
Display Example				

10.1.7 Set Display Offset (A2h)

This double byte command specifies the mapping of display start line (it is assumed that COM0 is the display start line, display start line register equals to 0) to one of COM0~COM79. Figure 25 shows an example using this command when MUX ratio= 80 and MUX ratio= 54 and Display Offset = 28. In there, “Row” means the graphic display data RAM row.

Figure 25: Example of Set Display Offset with no Remapping

	MUX ratio (A8h) = 80	MUX ratio (A8h) = 80	MUX ratio (A8h) = 64	MUX ratio (A8h) = 64
COM Pin	Display Offset (A2h)=0	Display Offset (A2h)=18	Display Offset (A2h)=0	Display Offset (A2h)=18
COM0	ROW0	ROW28	ROW0	ROW28
COM1	ROW1	ROW29	ROW1	ROW29
COM2	ROW2	ROW30	ROW2	ROW30
COM3	ROW3	ROW31	ROW3	ROW31
:	:	:	:	:
:	:	:	:	:
COM23	ROW23	ROW51	ROW23	ROW51
COM24	ROW24	ROW52	ROW24	ROW52
COM25	ROW25	ROW53	ROW25	ROW53
COM26	ROW26	ROW54	ROW26	-
:	:	:	:	:
:	:	:	:	:
COM49	ROW50	ROW77	ROW50	-
COM51	ROW51	ROW78	ROW51	-
COM52	ROW52	ROW79	ROW52	-
COM53	ROW53	ROW0	ROW53	ROW0
COM54	ROW54	ROW1	-	ROW1
COM55	ROW55	ROW2	-	ROW2
:	:	:	:	:
:	:	:	:	:
COM76	ROW76	ROW24	-	ROW24
COM77	ROW77	ROW25	-	ROW25
COM78	ROW78	ROW26	-	ROW26
COM79	ROW79	ROW27	-	ROW27
Display Example				

10.1.8 Set Display Mode (A4h ~ A7h)

These are single byte commands (A4h ~ A7h) and are used to set display status to Normal Display, Entire Display ON, Entire Display OFF or Inverse Display, respectively.

- Normal Display (A4h)
Reset the “Entire Display ON, Entire Display OFF or Inverse Display” effects and turn the data to ON at the corresponding gray level. Figure 26 shows an example of Normal Display.

Figure 26: Example of Normal Display



- Set Entire Display ON (A5h)
Force the entire display to be at gray scale level GS15, regardless of the contents of the display data RAM, as shown on Figure 27.

Figure 27: Example of Entire Display ON



- Set Entire Display OFF (A6h)
Force the entire display to be at gray scale level GS0, regardless of the contents of the display data RAM, as shown on Figure 28.

Figure 28 : Example of Entire Display OFF



- Inverse Display (A7h)
The gray scale level of display data are swapped such that “GS0” <-> “GS15”, “GS1” <-> “GS14”, etc. Figure 29 shows an example of inverse display.

Figure 29: Example of Inverse Display



10.1.9 Set Multiplex Ratio (A8h)

This double byte command sets multiplex ratio (MUX ratio) from 16MUX to 80MUX. In RESET, multiplex ratio is 80MUX. Please refer to Figure 24 and Figure 25 for the example of setting different MUX ratio.

10.1.10 Set Master Configuration (ADh)

This command selects the external V_{CC} power supply. External V_{CC} power should be connected to the V_{CC} pin. A[0] bit must be set to 0b after RESET.

This command will be activated after issuing Set Display ON command (AFh)

10.1.11 Set Display ON/OFF (AEh / AFh)

These single byte commands are used to turn the matrix display on the OLED panel display either ON or OFF. For AEh, the display is OFF, the segment and common output are in high impedance state and circuits will be turned OFF. When the sleep mode is set to OFF (AFh), the display is ON.

10.1.12 Set V_{COMH} Voltage (BEh)

This double byte command sets the high voltage level of common pins, V_{COMH} . The level of V_{COMH} is programmed with reference to V_{CC} . Please refer to Table 18 for detail information and breakdown levels of each step.

10.1.13 Set Precharge Voltage (BCh)

This double byte command is used to set the pre-charge voltage (phase 2) level. Please refer to Table 18 for detail information and breakdown levels of each step.

10.1.14 Set Phase Length (B1h)

This is a double byte command. In the second byte of this double command, lower nibble and higher nibble is defined separately. The lower nibble adjusts the phase length of Reset (phase 1). The higher nibble is used to select the phase length of the pre-charge phase (phase 2). The phase length is ranged from 1 to 16 DCLK's. RESET for A[3:0] is set to 3h while reset for A[7:4] is set to 5h. Please refer to Table 18 for detail breakdown levels of each step.

10.1.15 Set Row Period (B2h)

This command is used to set the row period. It is defined by multiplying the internal display clock period by the number of internal display clocks per row (valued from 14h to 7Fh), and RESET is 25h. The larger the value, the more precise of each gray scale level can be tuned. See “Gray Scale Table” command (B8h) for details. Also, it is used to define the frame frequency altogether with the use of “Display Clock Divide Ratio” command (B3h). Row period equals to the sum of phase 1 and phase 2 periods and the pulse width of GS15. See equation in Table 18.

10.1.16 Set Display Clock Divide Ratio (B3h)

This double command is used to set the frequency of the internal display clocks, DCLK's. It is defined by dividing the oscillator frequency by the divide ratio (valued from 1 to 16). Frame frequency is determined by divide ratio, number of display clocks per row, MUX ratio and oscillator frequency. The lower nibble of the second byte is used to select the oscillator frequency. Please refer to Table 18 for detail breakdown levels of each step.

10.1.17 Set Gray Scale Table

This command is used to set each individual gray scale level for the display. Except gray scale level GS0 that has no pre-charge and current drive, the pulse width of each gray scale level is programmed with unit of DCLK. The longer the length of the pulse width, the brighter the OLED pixel when it is turned ON.

The setting of gray scale table entry can perform gamma correction on OLED panel display. Normally, it is desired that the brightness response of the panel is linearly proportional to the image data value in display data RAM. However, the OLED panel is somehow responded in non-linear way. Appropriate gray scale table setting like example below can compensate this effect.

Figure 30 : Example of gamma correction by gray scale table setting

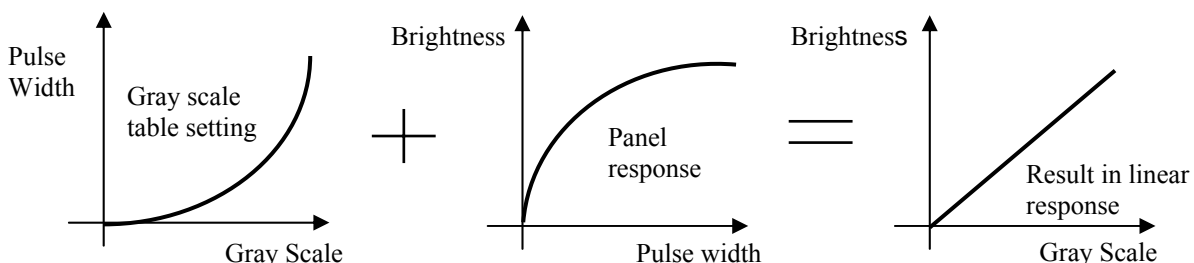

As shown in Table16 and

Table 17, GS1 is defined with pulse width equals to the first offset value, L1, select from 0-7 internal display clocks. GS2 is defined with pulse width equals to GS1 plus the next offset value, L2, select from 1-8 internal display clocks. Similarly, the next GS level is defined with pulse width equals to its lower one GS level plus the next offset value, select from 1-8 internal display clocks. In normal operation, GS15 should take the full current drive period as its pulse width. Therefore, the row period should be set as the

sum of phase 1 period, phase 2 periods, and the pulse width of GS15 with the use of “Row period” command.

10.1.18 NOP (E3h)

This is a no operation command.

10.1.19 Status register Read

This command is issued by setting D/C# LOW during a data read (refer to Figure 34 to Figure 36 parallel interface waveform). It allows the MCU to monitor the internal status of the chip.

10.2 Graphic Acceleration Command Set Description

10.2.1 Graphic Acceleration Command Options (23h)

This command has two functions.

- Enable / Disable fill (A[0])
0 = Disable filling of rectangle in draw rectangle command.
1 = Enable filling of rectangle in draw rectangle command. (RESET)
- Enable / Disable x-warp (A[1])
0 = Disable wrap around in x-direction during copying and scrolling
1 = Enable wrap around in x-direction during copying and scrolling (RESET)
- Enable / Disable reverse copy (A[4])
0 = Disable reverse copy (RESET)
1 = During copy command, the new image colors are swapped such that “GS0” <-> “GS15”, “GS1” <-> “GS14”,

10.2.2 Draw Rectangle (24h)

Specify a starting point (Row 1, Column 1) and an ending point (Row 2, Column 2) as well as giving the desired gray scale pattern, a rectangle will then be drawn.

Figure 31 : Example of draw rectangle command

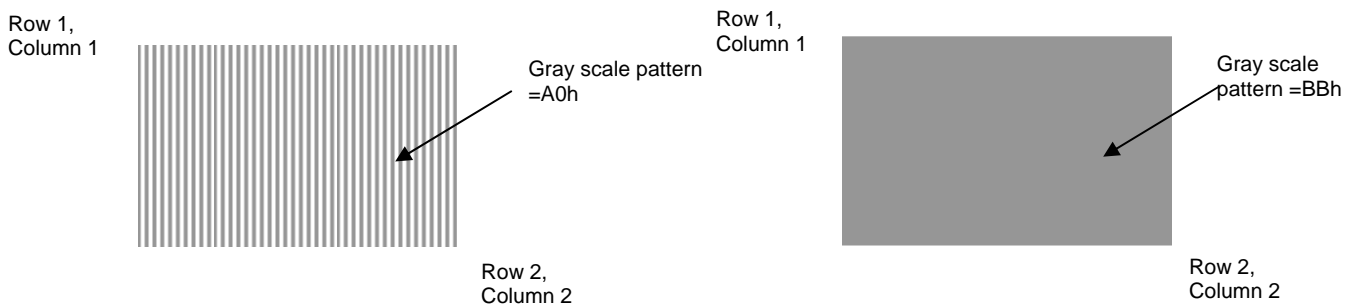

The following example illustrates the rectangle drawing command sequence.

1. Enter the “draw rectangle mode” by execute the command 24h
2. Set the starting column coordinates, Column 1. e.g., 01h.
3. Set the starting row coordinates, Row 1. e.g., 01h.
4. Set the finishing column coordinates, Column 9. e.g., 09h
5. Set the finishing row coordinates, Row 5. e.g., 05h
6. Set the gray scale pattern:

This byte is divided into two nibbles. The most significant 4 bits represent the gray scale level of the left pixel of each group. The least significant 4 bits represent the gray scale level of the right pixel of each group. Please refer to Figure 31 for the gray scale pattern setting examples.

10.2.3 Copy (25h)

Copy the rectangular region defined by the starting point (Row 1, Column 1) and the ending point (Row 2, Column 2) to location (Row 3, Column 3). If the new coordinates are smaller than the ending points, the new image will overlap the original one.

The following example illustrates the copy procedure.

1. Enter the “copy mode” by execute the command 25h
2. Set the starting column coordinates, Column 1. E.g., 00h.
3. Set the starting row coordinates, Row 1. E.g., 00h.
4. Set the finishing column coordinates, Column 2. E.g., 05h
5. Set the finishing row coordinates, Row 2. E.g., 05h
6. Set the new column coordinates, Column 3. E.g., 03h
7. Set the new row coordinates, Row 3. E.g., 03h

Figure 32: Example of copy command

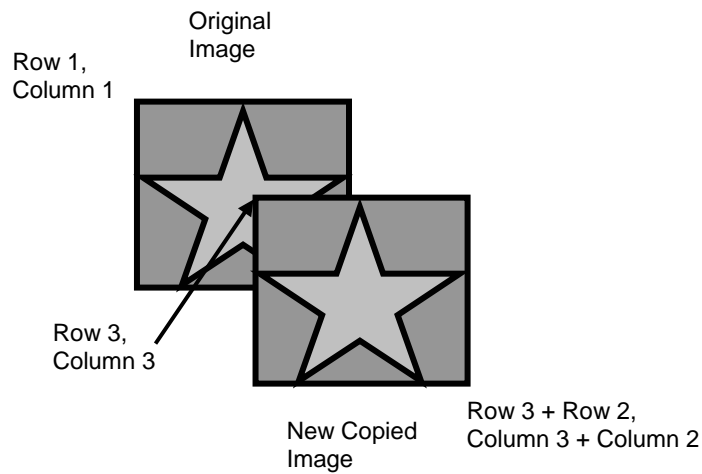

10.2.4 Horizontal Scroll (26h)

This command consists of 3 consecutive bytes to set up the scrolling parameters. It determined the horizontal scrolling offset, no of scrolling row and scrolling speed. Some scrolling examples are shown in Figure 33 .

Before issuing this command, the scrolling must be deactivated (2Eh). Otherwise, RAM content may be corrupted.

Figure 33: Scrolling examples

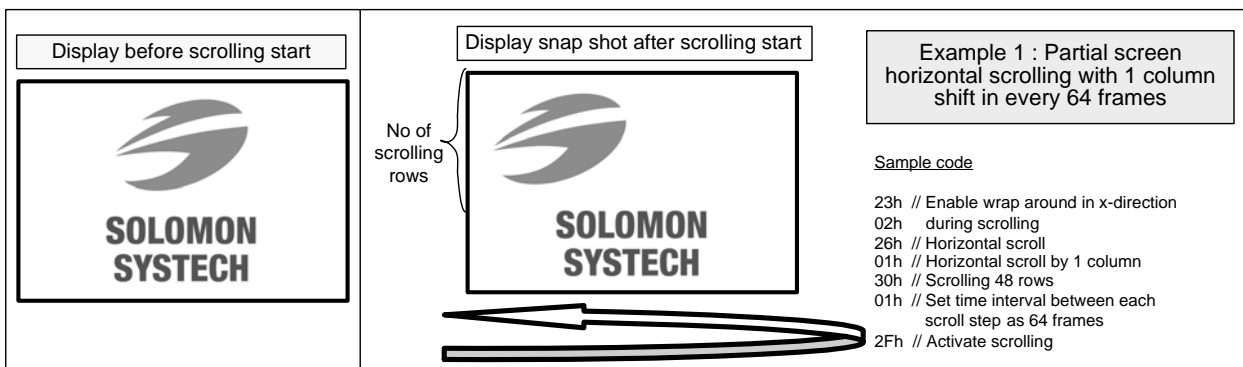

10.2.5 Stop Moving (2Eh)

Stop motion of scrolling. After sending 2Eh command to deactivate the scrolling action, the ram data needs to be rewritten.

10.2.6 Start Moving (2Fh)

Start motion of scrolling. This command should only be issued after scrolling setup parameters are defined through command 26h and the function of wrap around in x-direction is enabled through 23h.

The following actions are prohibited after the horizontal scroll is activated

1. RAM access (Data write or read)
2. Changing scrolling setup parameters

11 MAXIMUM RATINGS

Table 22 : Maximum Ratings (Voltage Reference to V_{SS})

Symbol	Parameter	Value	Unit
V _{DD}	Supply Voltage	-0.3 to +4.0	V
V _{CC}		0 to +17.0	V
V _{REF}		0 to +17.0	V
V _{SEG}	SEG output voltage	0 to +V _{CC}	V
V _{COM}	COM output voltage	0 to +0.9xV _{CC}	
V _{in}	Input voltage	V _{SS} -0.3 to V _{DD} +0.3	V
T _A	Operating Temperature	-40 to +85	°C
T _{stg}	Storage Temperature Range	-65 to +150	°C

Maximum Ratings are those values beyond which damage to the device may occur. Functional operation should be restricted to the limits in the Electrical Characteristics tables or Pin Description.

This device may be light sensitive. Caution should be taken to avoid exposure of this device to any light source during normal operation. This device is not radiation protected.

12 DC CHARACTERISTICS

Conditions (unless specified):

Voltage referenced to V_{SS} ;

$V_{DD} = 2.7$, $V_{CC} = 12.0V$, $I_{REF} = 10\mu A$, at $T_A = 25^\circ C$.

Table 23 : DC Characteristics

Symbol	Parameter	Test Condition	Min	Typ	Max	Unit
V_{CC}	Operating Voltage	-	8.0	12.0	16.0	V
V_{DD}	Logic Supply Voltage	-	2.4	2.7	3.5	V
V_{OH}	HIGH Logic Output Level	$I_{OUT} = 100\mu A$, 3.3MHz	$0.9 * V_{DD}$	-	V_{DD}	V
V_{OL}	LOW Logic Output Level	$I_{OUT} = 100\mu A$, 3.3MHz	0	-	$0.1 * V_{DD}$	V
V_{IH}	HIGH Logic Input Level	-	$0.8 * V_{DD}$	-	V_{DD}	V
V_{IL}	LOW Logic Input Level	-	0	-	$0.2 * V_{DD}$	V
I_{SLEEP}	Sleep mode Current	No loading	-	0.2	5	μA
I_{CC}	V_{CC} Supply Current $V_{DD} = 2.7V$, external $V_{CC} = 12V$, $I_{REF} = 10\mu A$, Frame rate=110Hz, All one pattern, Display ON, no loading	Contrast = 7F	-	700	-	μA
I_{DD}	V_{DD} Supply Current $V_{DD} = 2.7V$, external $V_{CC} = 12V$, $I_{REF} = 10\mu A$, Frame rate=110Hz, All one pattern, Display ON, no loading	Contrast = 7F	-	-	650	μA
I_{SEG}	Segment Output Current $V_{DD} = 2.7V$, $V_{CC} = 12V$, $I_{REF} = 10\mu A$, Frame rate=110Hz, Display ON, Segment pin under test is connected with a 20K resistive load to V_{SS}	Contrast = 7F	270	300	370	μA
		Contrast = 5F	-	225	-	
		Contrast = 3F	-	150	-	
		Contrast = 1F	-	75	-	
Dev	Segment output current uniformity $V_{DD} = 2.7V$, $V_{CC} = 12V$, $I_{REF} = 10\mu A$, Contrast=7F	Adjacent pin	-1.5	-	+1.5	%
		Overall pin to pin	-3	-	+3	

13 AC CHARACTERISTICS

Conditions (Unless otherwise specified):

Voltage referenced to V_{SS}

$V_{DD} = 2.4V$ to $3.5V$

$V_{CC} = 8.0V$ to $16.0V$

$T_A = 25^\circ C$

Table 24 : AC Characteristics

Symbol	Parameter	Test Condition	Min	Typ	Max	Unit
F_{OSC}	Oscillation Frequency of Display Timing Generator	$V_{DD} = 2.7V$	535	630	725	kHz
F_{FRM}	Frame Frequency for 128 MUX Mode	128x80 Graphic Display Mode, Display ON, Internal Oscillator Enabled	-	$F_{OSC} * 1/(D*K*80)$	-	Hz
RES#	Reset LOW pulse width	-	3	-	-	us
	Reset complete time	-	-	-	2	us

Note:

- (1) F_{OSC} stands for the frequency value of the internal oscillator and the value is measured when command B3h A[7:4] is in default value.
- (2) D stands for divide ratio
- (3) K stands for total number of display clocks per row defined by command B2h
- (4) N stands for number of MUX selected by command A8h

Conditions:

$V_{DD} - V_{SS} = 2.4 \text{ to } 3.5V$

$T_A = 25^\circ C$

Table 25 : 6800-Series MPU Parallel Interface Timing Characteristics

Symbol	Parameter	Min	Typ	Max	Unit
t_{cycle}	Clock Cycle Time	300	-	-	ns
t_{AS}	Address Setup Time	0	-	-	ns
t_{AH}	Address Hold Time	0	-	-	ns
t_{DSW}	Write Data Setup Time	40	-	-	ns
t_{DHW}	Write Data Hold Time	15	-	-	ns
t_{DHR}	Read Data Hold Time	20	-	-	ns
t_{OH}	Output Disable Time	-	-	70	ns
t_{ACC}	Access Time	-	-	140	ns
PW_{CSL}	Chip Select Low Pulse Width (read)	120	-	-	ns
	Chip Select Low Pulse Width (write)	60	-	-	ns
PW_{CSH}	Chip Select High Pulse Width (read)	60	-	-	ns
	Chip Select High Pulse Width (write)	60	-	-	ns
t_R	Rise Time	-	-	15	ns
t_F	Fall Time	-	-	15	ns

Figure 34 : 6800-series MPU Parallel Interface Characteristics

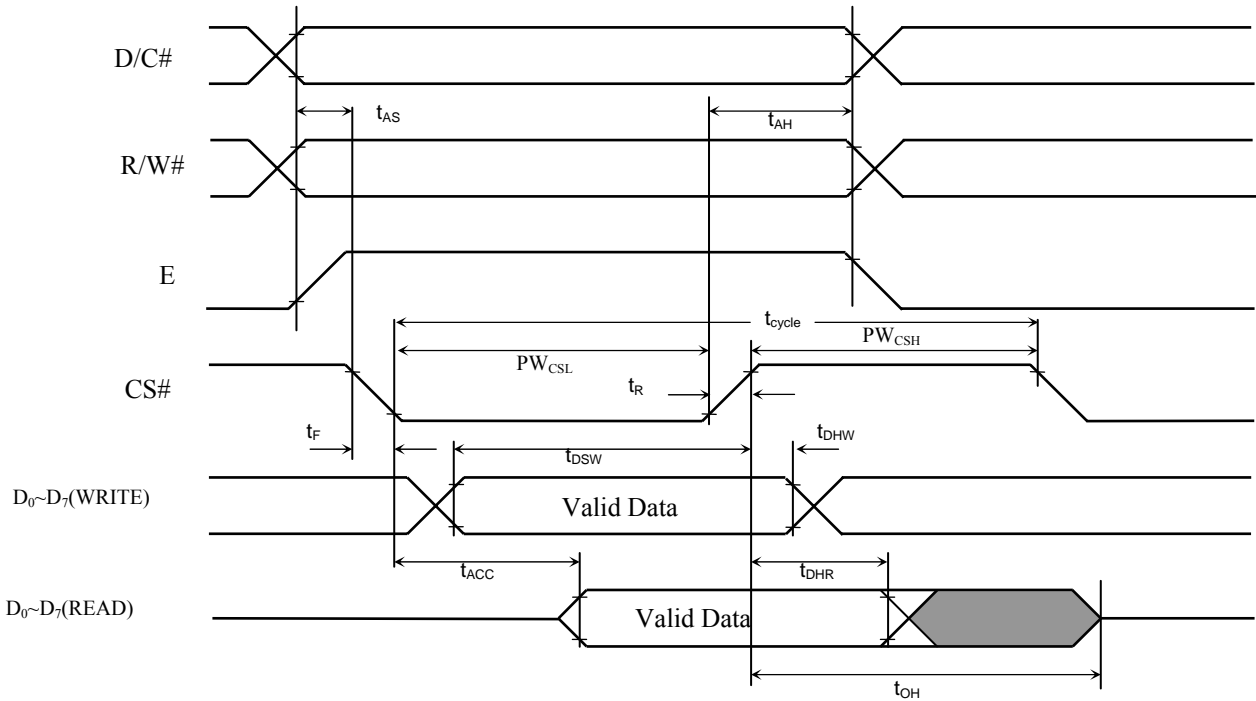

Conditions:

$V_{DD} - V_{SS} = 2.4 \text{ to } 3.5\text{V}$

$T_A = 25^\circ\text{C}$

Table 26 : 8080-Series MPU Parallel Interface Timing Characteristics

Symbol	Parameter	Min	Typ	Max	Unit
t_{cycle}	Clock Cycle Time	300	-	-	ns
t_{AS}	Address Setup Time	10	-	-	ns
t_{AH}	Address Hold Time	0	-	-	ns
t_{DSW}	Write Data Setup Time	40	-	-	ns
t_{DHW}	Write Data Hold Time	15	-	-	ns
t_{DHR}	Read Data Hold Time	20	-	-	ns
t_{OH}	Output Disable Time	-	-	70	ns
t_{ACC}	Access Time	-	-	140	ns
t_{PWLR}	Read Low Time	120	-	-	ns
t_{PWLW}	Write Low Time	60	-	-	ns
t_{PWHR}	Read High Time	60	-	-	ns
t_{PWHW}	Write High Time	60	-	-	ns
t_R	Rise Time	-	-	15	ns
t_F	Fall Time	-	-	15	ns
t_{CS}	Chip select setup time	0	-	-	ns
t_{CSH}	Chip select hold time to read signal	0	-	-	ns
t_{CSF}	Chip select hold time	20	-	-	ns

Figure 35 : 8080-series parallel interface characteristics (Form 1)

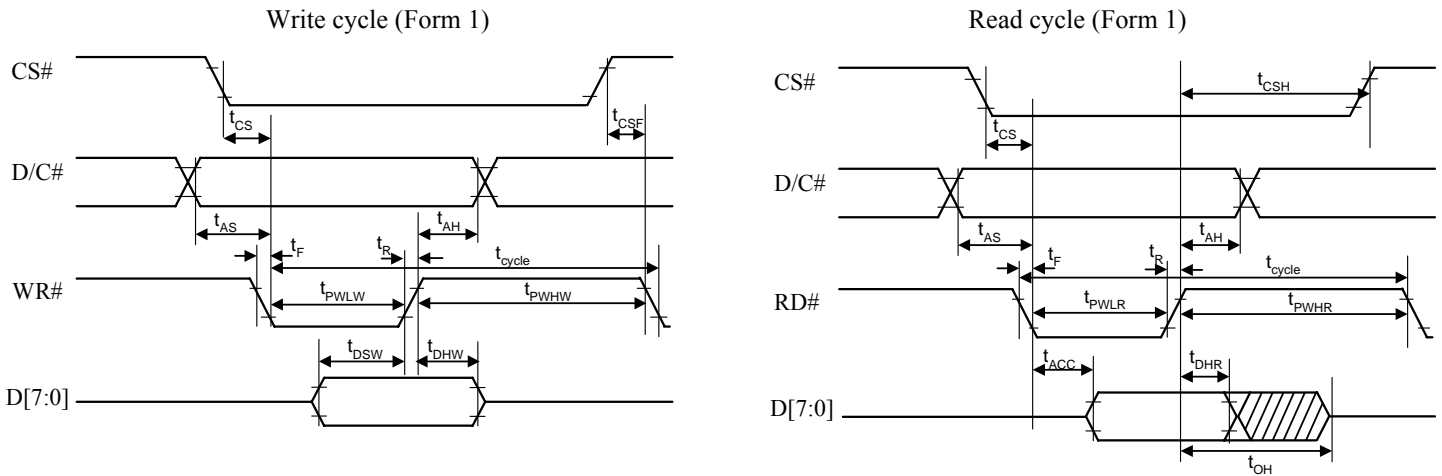
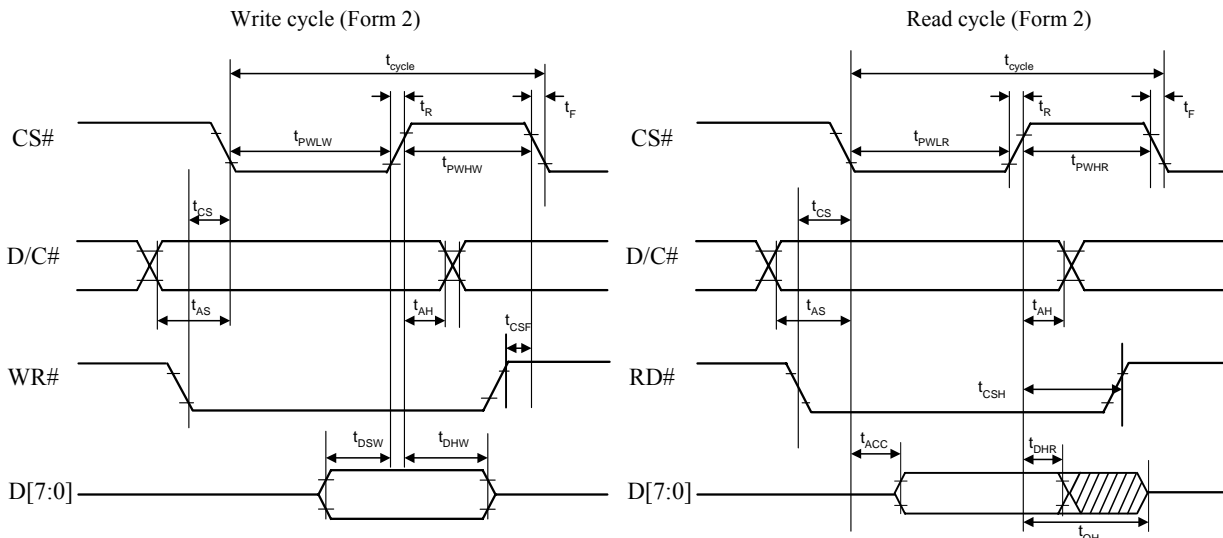

Figure 36 : 8080-series parallel interface characteristics (Form 2)



Conditions:

$V_{DD} - V_{SS} = 2.4 \text{ to } 3.5\text{V}$

$T_A = 25^\circ\text{C}$

Table 27 : Serial Interface Timing Characteristics

Symbol	Parameter	Min	Typ	Max	Unit
t_{cyle}	Clock Cycle Time	250	-	-	ns
t_{AS}	Address Setup Time	150	-	-	ns
t_{AH}	Address Hold Time	150	-	-	ns
t_{CSS}	Chip Select Setup Time	120	-	-	ns
t_{CSH}	Chip Select Hold Time	60	-	-	ns
t_{DSW}	Write Data Setup Time	100	-	-	ns
t_{DHW}	Write Data Hold Time	100	-	-	ns
t_{CLKL}	Clock Low Time	100	-	-	ns
t_{CLKH}	Clock High Time	100	-	-	ns
t_R	Rise Time	-	-	15	ns
t_F	Fall Time	-	-	15	ns

Figure 37 : Serial Interface Characteristics

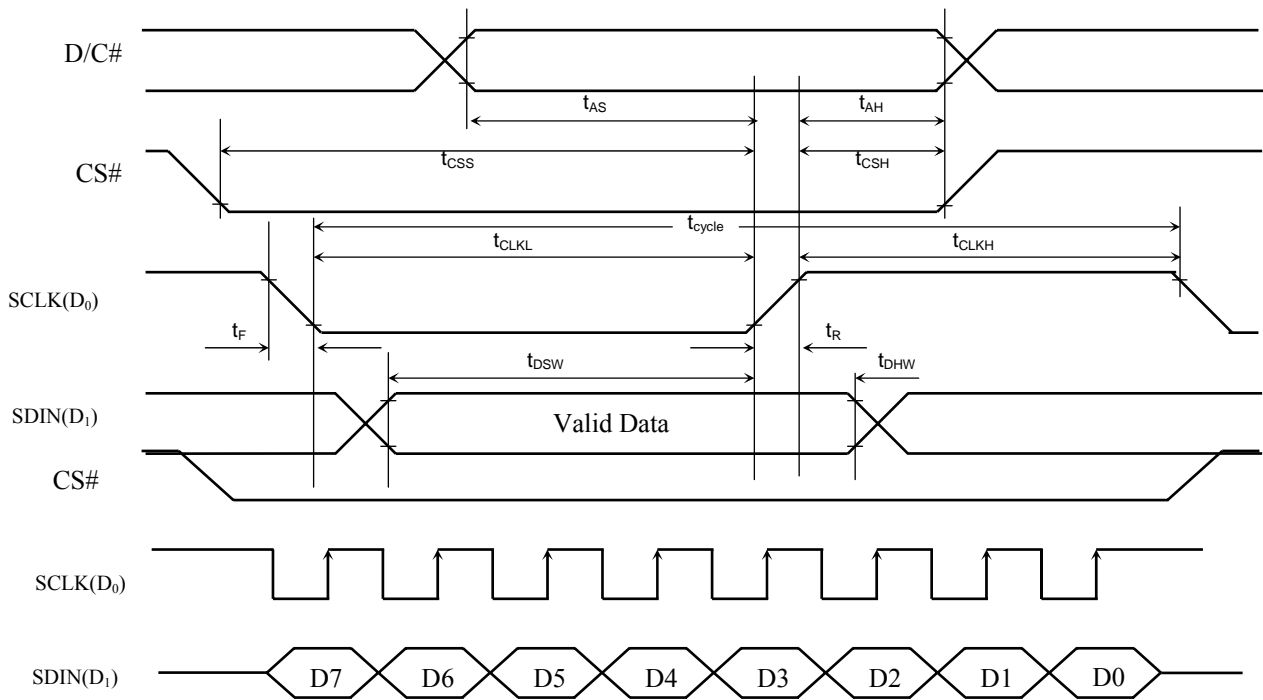

14 APPLICATION EXAMPLES

Figure 38 : Application Example for SSD1325Z SPI serial interface mode

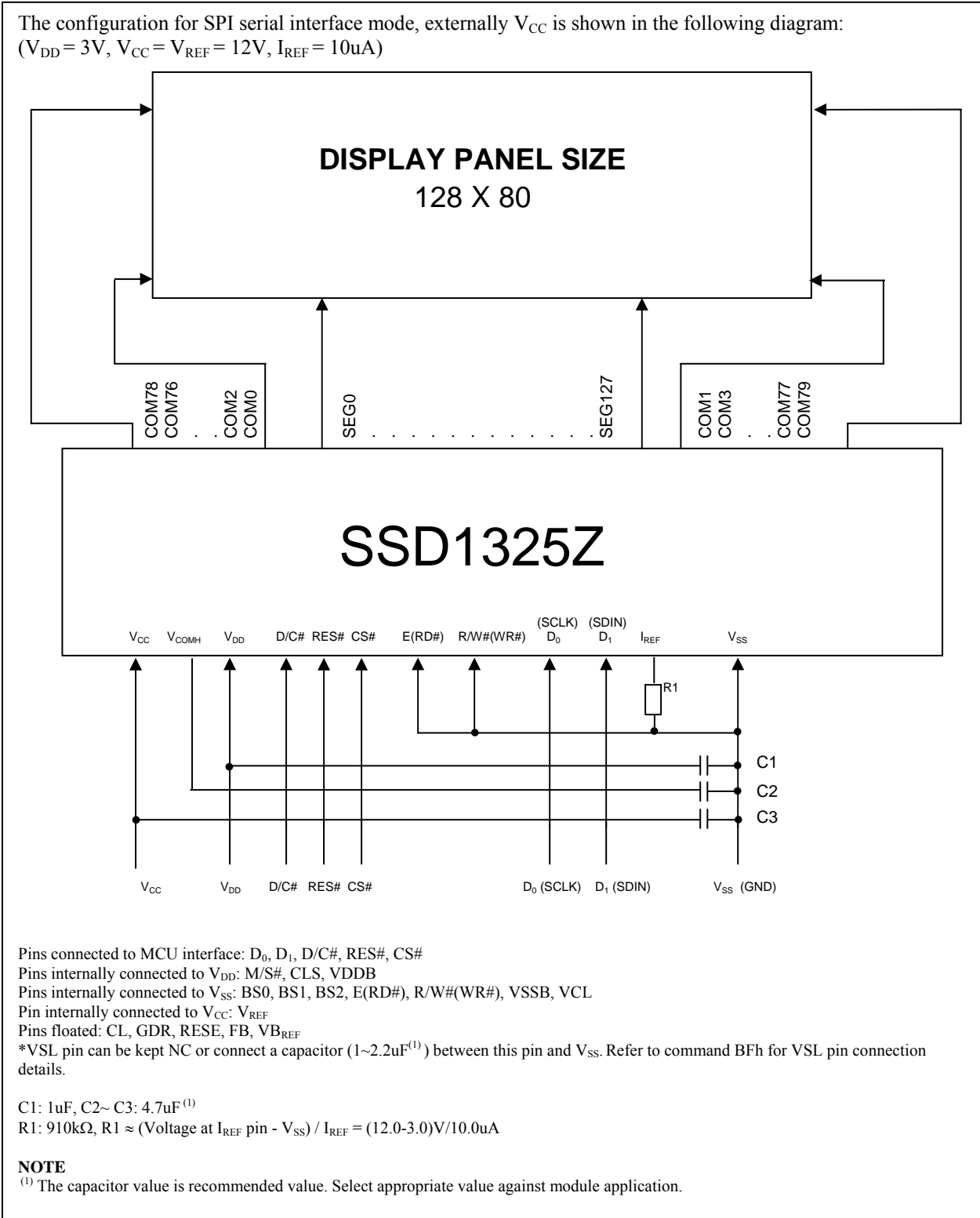
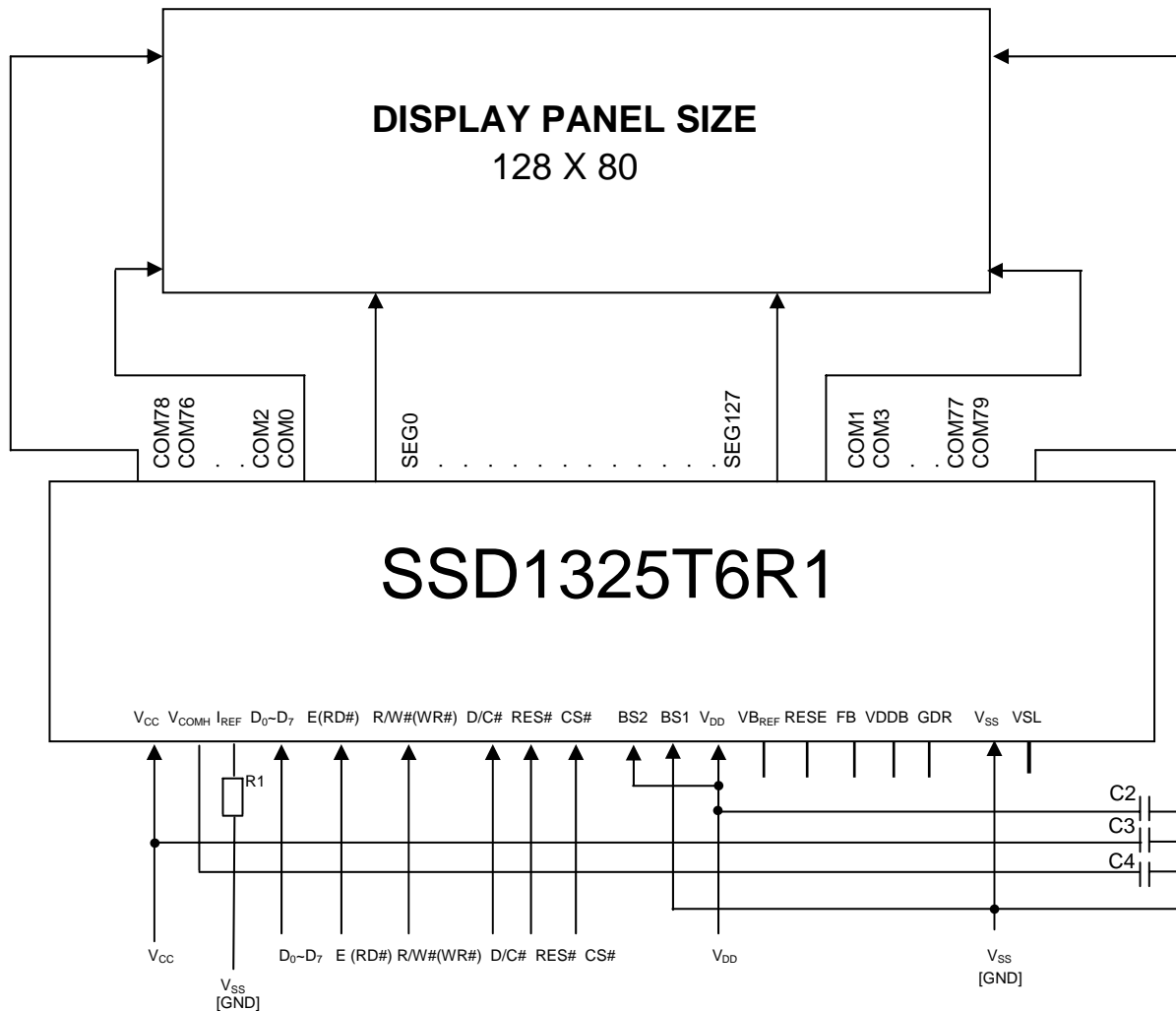

Figure 39: Application Example for SSD1325T6R1

The configuration for 6800-parallel interface mode, externally V_{CC} is shown in the following diagram:
 ($V_{DD} = 3V$, $V_{CC} = V_{REF} = 12V$, $I_{REF} = 10\mu A$)



Pins connected to MCU interface: $D_0 \sim D_7$, $E(RD\#)$, $R/W\#(WR\#)$, $D/C\#$, $CS\#$, $RES\#$

Pins internally connected to V_{DD} : $M/S\#$, CLS

Pins internally connected to V_{SS} : $BS0$, $VSSB$

Pin internally connected to V_{CC} : V_{REF}

Pins floated: GDR , $RESE$, FB , VB_{REF} , $VDDB$

* VSL pin can be kept NC or connect a capacitor ($1 \sim 2.2\mu F^{(1)}$) between this pin and V_{SS} . Refer to command BFh for VSL pin connection details.

$C2 \sim C4$: $4.7\mu F^{(1)}$

$R1$: $910k\Omega$, $R1 \approx (Voltage\ at\ I_{REF}\ pin - V_{SS}) / I_{REF} = (12.0 - 3.0)V / 10.0\mu A$

Note

⁽¹⁾ The capacitor value is recommended value. Select appropriate value against module application.

15 PACKAGE INFORMATION

15.1 SSD1325Z Die Tray Information

Figure 40 : SSD1325Z Die Tray Drawing

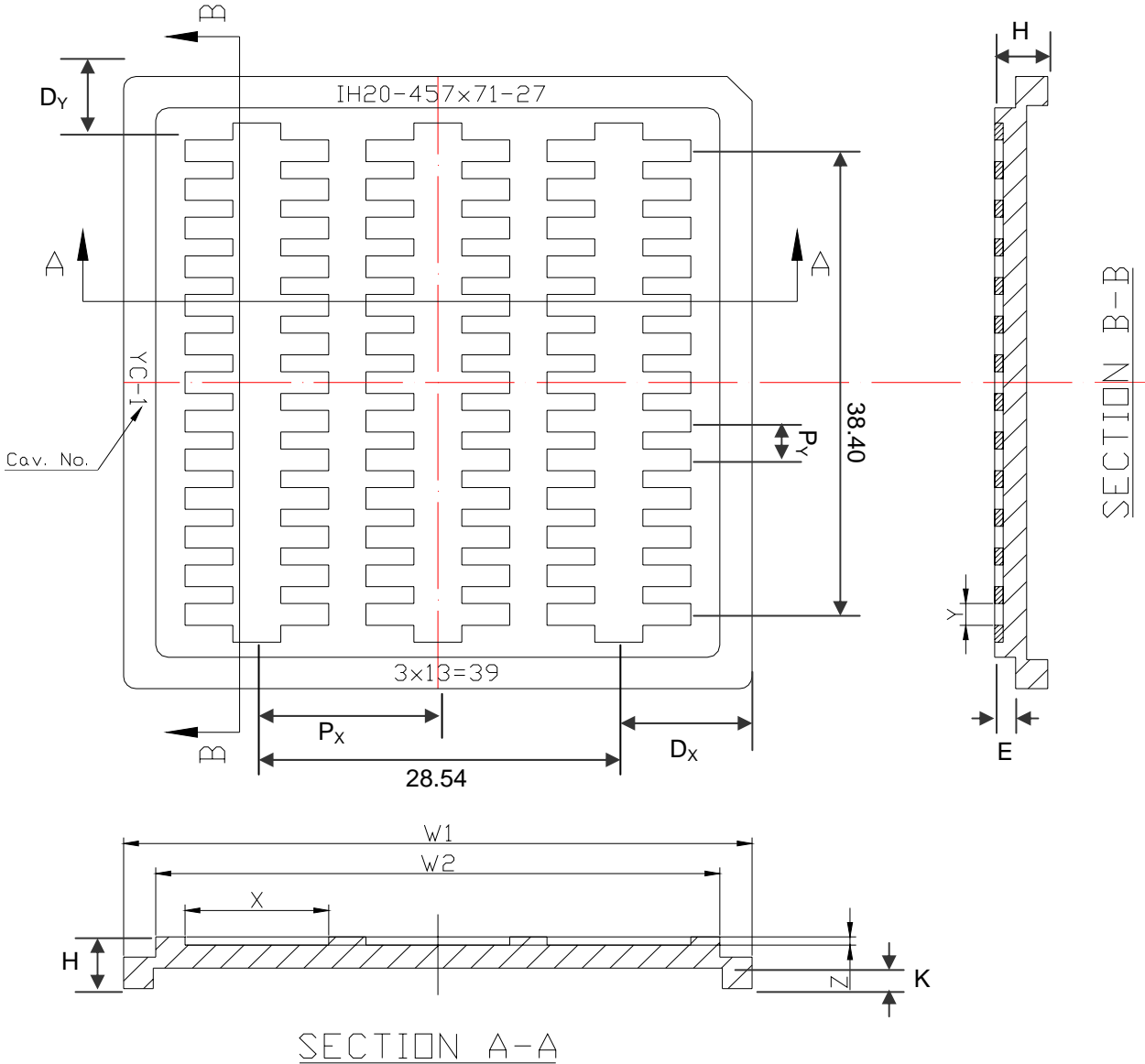

Remark

1. Depth of text: Max. 0.1mm
2. Tray material: ABS
3. Tray color code: Black
4. Surface resistance $10^9 \sim 10^{11} \Omega$
5. Tray warpage: Max 0.10mm
6. Unspecifier dim's tolerance: $\pm 0.15\text{mm}$
7. Pocket size: 13.56 x 1.65 x 0.61mm

Table 28 : SSD1325Z Die Tray Dimensions

Parameter	Dimensions	
	mm	(mil)
W1	50.70±0.2	(1996)
W2	45.50±0.2	(1791)
H	4.05±0.2	(160)
E	1.75±0.2	(69)
K	1.45±0.2	(57)
P _X	14.27±0.1	(562)
P _Y	3.20±0.1	(126)
X	11.60±0.1	(457)
Y	1.80±0.1	(71)
Z	0.68±0.05	(27)
D _X	11.08±0.1	(437)
D _Y	6.15±0.1	(242)
N (number of die)	39	

NOTE:

1. GENERAL TOLERANCE: $\pm 0.05\text{mm}$
2. CUTLINE TOLERANCE: $\pm 0.15\text{mm}$
3. MATERIAL
 - PI: $75\pm 6\mu\text{m}$
 - CU: $18\pm 5\mu\text{m}$
 - SR: $26\pm 14\mu\text{m}$
 - ADHESIVE: $12\pm 2\mu\text{m}$
4. FLEX COATING: Min10 μm
5. SN PLATING: $0.20\pm 0.05\mu\text{m}$
6. TAP SITE: 4 SPH, 19.00mm

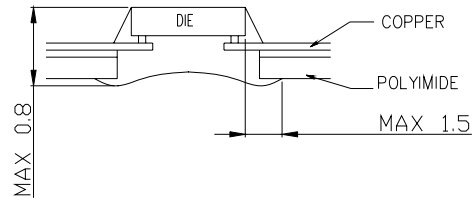

MIRROR DESIGN

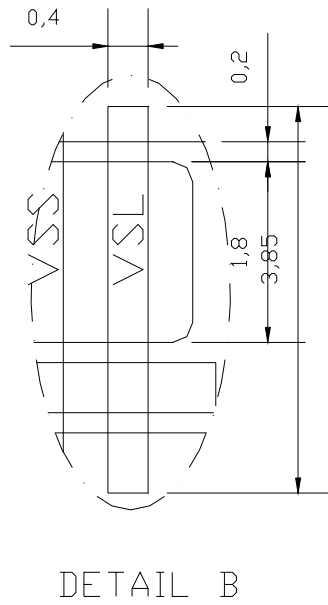
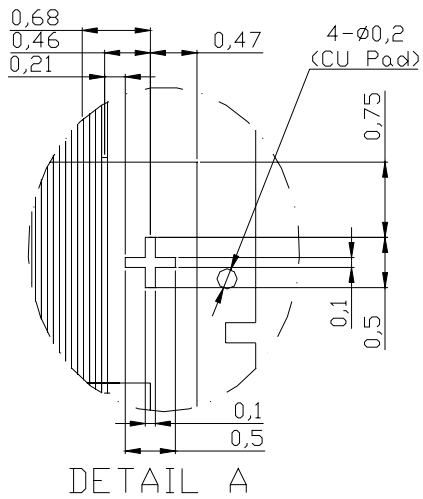

Solomon Systech reserves the right to make changes without further notice to any products herein. Solomon Systech makes no warranty, representation or guarantee regarding the suitability of its products for any particular purpose, nor does Solomon Systech assume any liability arising out of the application or use of any product or circuit, and specifically disclaims any and all liability, including without limitation consequential or incidental damages. "Typical" parameters can and do vary in different applications. All operating parameters, including "Typicals" must be validated for each customer application by customer's technical experts. Solomon Systech does not convey any license under its patent rights nor the rights of others. Solomon Systech products are not designed, intended, or authorized for use as components in systems intended for surgical implant into the body, or other applications intended to support or sustain life, or for any other application in which the failure of the Solomon Systech product could create a situation where personal injury or death may occur. Should Buyer purchase or use Solomon Systech products for any such unintended or unauthorized application, Buyer shall indemnify and hold Solomon Systech and its offices, employees, subsidiaries, affiliates, and distributors harmless against all claims, costs, damages, and expenses, and reasonable attorney fees arising out of, directly or indirectly, any claim of personal injury or death associated with such unintended or unauthorized use, even if such claim alleges that Solomon Systech was negligent regarding the design or manufacture of the part.

All Solomon Systech Products complied with six (6) hazardous substances limitation requirement per European Union (EU) "Restriction of Hazardous Substance (RoHS) Directive (2002/95/EC)" and China standard "电子信息产品污染控制标识要求 (SJ/T11364-2006)" with control Marking  . Hazardous Substances test report is available upon requested.

<http://www.solomon-systech.com>