

Crystalfontz America, Inc.

SPECIFICATION

CUSTOMER : _____

MODULE NO.: CFAG12232A-TMI-TA

SALES BY	APPROVED BY	CHECKED BY	PREPARED BY
ISSUED DATE:			

Crystalfontz America, Inc.

12412 East Saltese Avenue
Spokane Valley, WA 99216-0357

Phone: (888) 206-9720

Fax: (509) 892-1203

Email: techinfo@crystalfontz.com

URL: www.crystalfontz.com

Contents

1. Module Classification Information
2. Precautions in use of LCD Modules
3. General Specification
4. Absolute Maximum Ratings
5. Electrical Characteristics
6. Optical Characteristics
7. Interface Description
8. Contour Drawing & Block Diagram
9. Function Description
10. Commands Description
11. Timing Characteristics
12. Reliability
13. Backlight Information
14. Material List of Components for RoHS

1.Module Classification Information

CFA G 1 2 2 3 2 A T M I TA
 ① ② ③ ④ ⑤ ⑥ ⑦ ⑧

①	Brand: CRYSTALFONTZ AMERICA, INC	
②	Display Type: H→Character Type, G→Graphic Type	
③	Displays Logical Dimensions: 122 Pixels x 32 Pixels	
④	Model PCB Variant: A	
⑤	Backlight Type:	N→Without backlight B→EL, Blue green D→EL, Green W→EL, White F→CCFL, White Y→LED, Yellow Green T→LED, White A→LED, Amber R→LED, Red O→LED, Orange G→LED, Green
⑥	LCD Mode:	B→TN Positive, Gray T→FSTN Negative N→TN Negative, G→STN Positive, Gray Y→STN Positive, Yellow Green M→STN Negative, Blue F→FSTN Positive
⑦	LCD Polarizer Type/ Temperature range/ View direction	A→Reflective, N.T, 6:00 D→Reflective, N.T, 12:00 G→Reflective, W. T, 6:00 J→Reflective, W. T, 12:00 B→Transflective, N.T,6:00 E→Transflective, N.T.12:00 H→Transflective, W.T,6:00 K→Transflective, W.T,12:00 C→Transmissive, N.T,6:00 F→Transmissive, N.T,12:00 I→Transmissive, W. T, 6:00 L→Transmissive, W.T,12:00
⑧	Special Code	T→Temperature compensation circuit on board; A→Avant IC

2.Precautions in use of LCD Modules

- (1) Avoid applying excessive shocks to the module or making any alterations or modifications to it.
- (2) Don't make extra holes on the printed circuit board, modify its shape or change the components of LCD module.
- (3) Don't disassemble the LCM.
- (4) Don't operate it above the absolute maximum rating.
- (5) Don't drop, bend or twist LCM.
- (6) Soldering: only to the I/O terminals.
- (7) Storage: please storage in anti-static electricity container and clean environment.

3.General Specification

Item	Dimension	Unit
Number of Characters	122 x 32 dot	—
Module dimension	84.0 x 44.0 x 14.2(MAX)	mm
View area	60.0 x 18.0	mm
Active area	53.64 x 15.64	mm
Dot size	0.4 x 0.45	mm
Dot pitch	0.44 x 0.49	mm
LCD type	STN, Negative, Transmissive Blue	
Duty	1/32	
View direction	6 o'clock	
Backlight Type	LED White	

4. Absolute Maximum Ratings

Item	Symbol	Min	Typ	Max	Unit
Operating Temperature	T_{OP}	-20	—	70	°C
Storage Temperature	T_{ST}	-30	—	+80	°C
Input Voltage	V_I	0	—	V_{DD}	V
Supply Voltage For Logic	V_{DD}	0	—	6.7	V
Supply Voltage For LCD	$V_{DD}-V_{LCD}$	0	—	-10	V
Supply Voltage For LCD	VEE	—	—	-5	V

5. Electrical Characteristics

Item	Symbol	Condition	Min	Typ	Max	Unit
Supply Voltage For Logic	$V_{DD}-V_{SS}$	—	4.5	5.0	5.5	V
Supply Voltage For LCD	$V_{DD}-V_0$	Ta=-20°C	—	—	5.7	V
		Ta=25°C	—	—	—	V
		Ta=+70°C	—	4.7	—	V
			4.1	—	—	V
Input High Volt.	V_{IH}	—	2.0	—	V_{DD}	V
Input Low Volt.	V_{IL}	—	0	—	0.8	V
Output High Volt.	V_{OH}	—	2.7	—	V_{DD}	V
Output Low Volt.	V_{OL}	—	0	—	0.4	V
Supply Current	I_{DD}	—	4,5	5.0	6.0	mA

6. Optical Characteristics

Item	Symbol	Condition	Min	Typ	Max	Unit
View Angle	(V) θ	$CR \geq 2$	20	—	40	deg
	(H) ϕ	$CR \geq 2$	-30	—	30	deg
Contrast Ratio	CR	—	—	3	—	—
Response Time	T rise	—	—	100	150	ms
	T fall	—	—	100	150	ms

Definition of Operation Voltage (Vop)

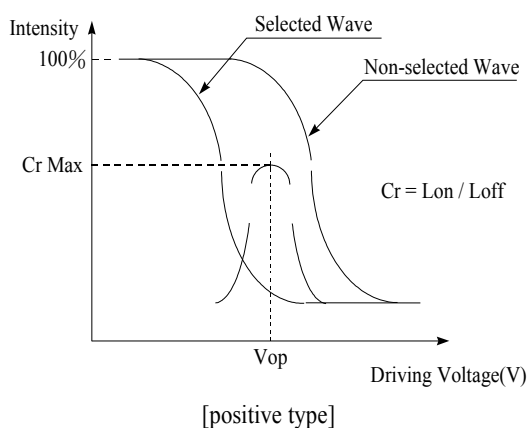

Definition of Response Time (Tr, Tf)

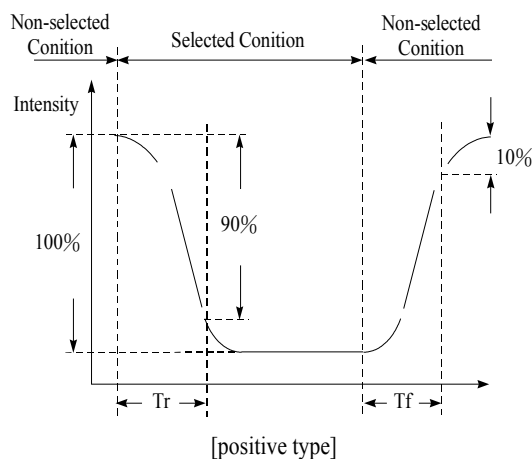

Conditions :

Operating Voltage : Vop

Viewing Angle(θ , ϕ) : 0° , 0°

Frame Frequency : 64 HZ

Driving Waveform : 1/N duty, 1/a bias

Definition of viewing angle($CR \geq 2$)

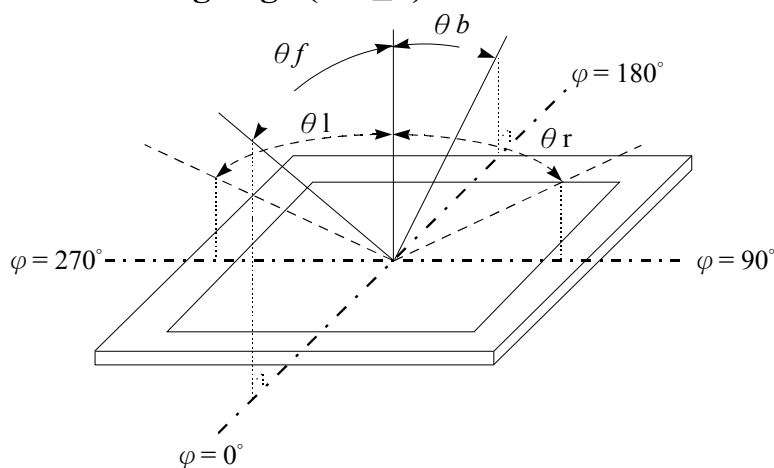

7.Interface Description

Pin No.	Symbol	Level	Description
1	V _{ss}	0V	Ground
2	V _{dd}	5.0V	Power supply for logic
3	V _o	(Variable)	Operating voltage for LCD
4	A0	H/L	H : Data L : Instruction
5	CS1	H/L	Chip select signal for IC1 (left 61*32 dots) active "H"
6	CS2	H/L	Chip select signal for IC2 (right 61*32 dots) active "H"
7	NC	—	NC
8	NC	—	NC
9	R/W	H/L	H : Read ; L : Write (68 series MPU interface only)
10	DB0	H/L	Data bus line
11	DB1	H/L	Data bus line
12	DB2	H/L	Data bus line
13	DB3	H/L	Data bus line
14	DB4	H/L	Data bus line
15	DB5	H/L	Data bus line
16	DB6	H/L	Data bus line
17	DB7	H/L	Data bus line
18	RES	H/L	H -> L: The LCM be reset
19	V _{ee}	—	Negative voltage
20	NC	—	

8. Contour Drawing & Block Diagram

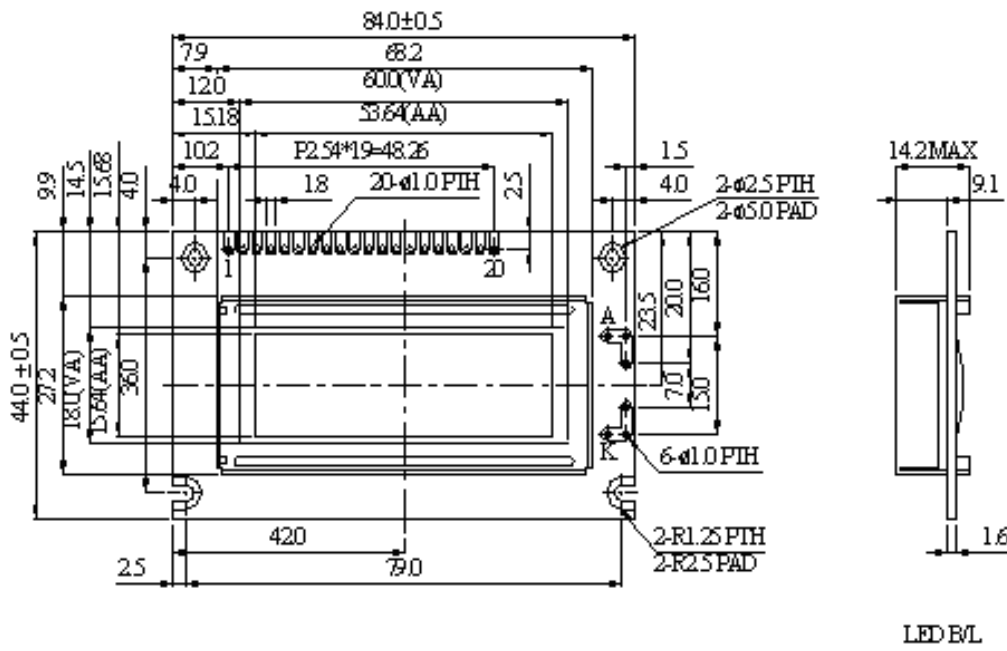

1	V _{ss}
2	V _{dd}
3	V _o
4	A0
5	CS1
6	CS2
7	NC
8	NC
9	R/W
10	DB0
11	DB1
12	DB2
13	DB3
14	DB4
15	DB5
16	DB6
17	DB7
18	RES
19	V _{ee}
20	NC

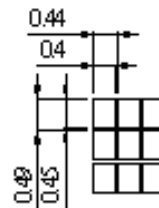

DOTSIZE

The non-specified tolerance of dimension is ±0.3mm.

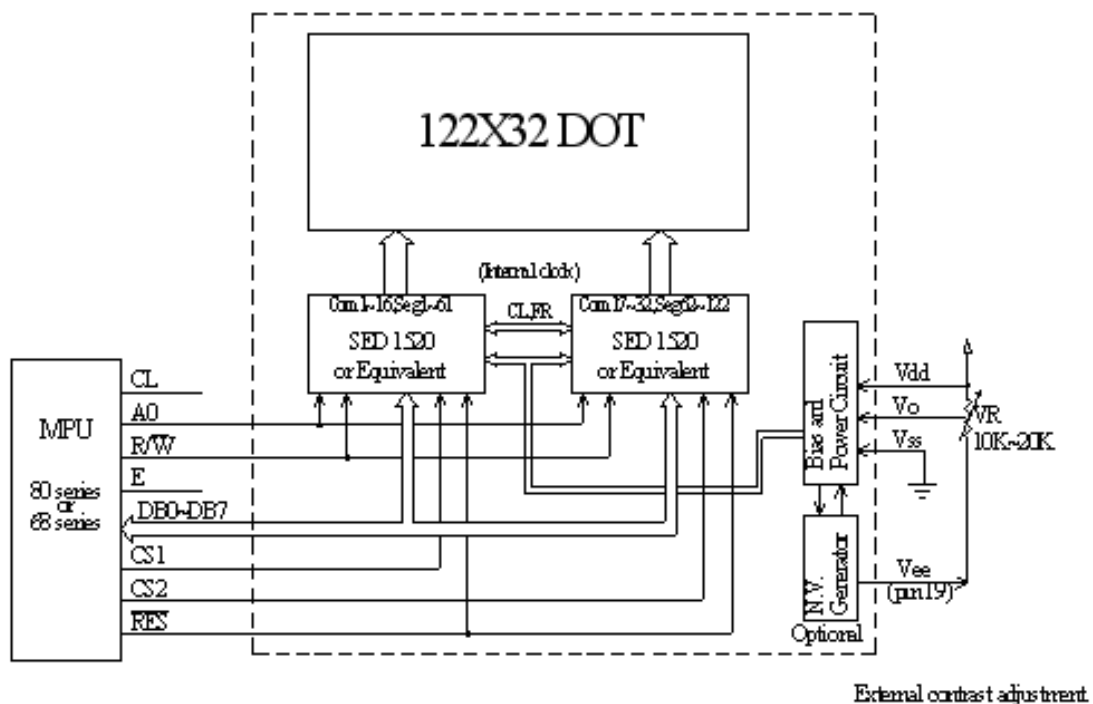

External contrast adjustment

9. Timing Characteristics

CL and FR timing

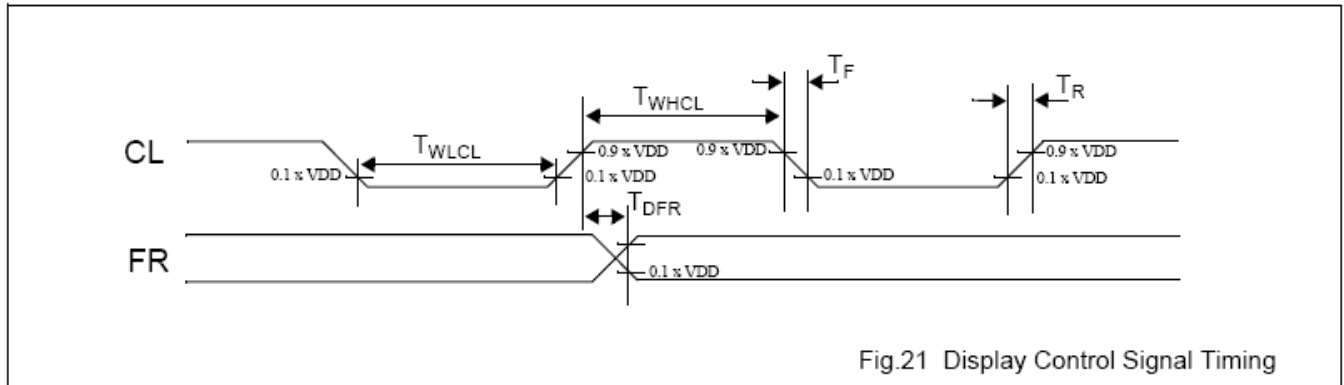

Fig.21 Display Control Signal Timing

CL and FR timing characteristics at VDD=5 volts

VDD = 5 V ±10%; VSS = 0 V; all voltages with respect to VSS unless otherwise specified; Tamb = -20 to +75 °C.

SYMBOL	PARAMETER	CONDITIONS	MIN.	TYP.	MAX.	UNIT
T_{WHCL}	CL clock high pulse width		33			μs
T_{WLCL}	CL clock low pulse width		33			μs
T_R	CL clock rise time			28	120	ns
T_F	CL clock fall time			28	120	ns
$T_{DFR(input)}$	FR delay time (input)	When used as input in Slave Mode application	-2.0	0.2	1.6	μs
$T_{DFR(output)}$	FR delay time (output)	When used as output in Master Mode application, with CL= 100 pF.		0.2	0.36	μs

CL and FR timing characteristics at VDD=3 volts

VDD = 3 V ±10%; VSS = 0 V; all voltages with respect to VSS unless otherwise specified; Tamb = -20 to +75 °C.

SYMBOL	PARAMETER	CONDITIONS	MIN.	TYP.	MAX.	UNIT
T_{WHCL}	CL clock high pulse width		65			μs
T_{WLCL}	CL clock low pulse width		65			μs
T_R	CL clock rise time			50	220	ns
T_F	CL clock fall time			50	220	ns
$T_{DFR(input)}$	FR delay time (input)	When used as input in Slave Mode application	-3.6	0.36	3.6	μs
$T_{DFR(output)}$	FR delay time (output)	When used as output in Master Mode application, with CL= 100 pF.		0.32	0.6	μs

AC timing for interface with an 80-type microcontroller

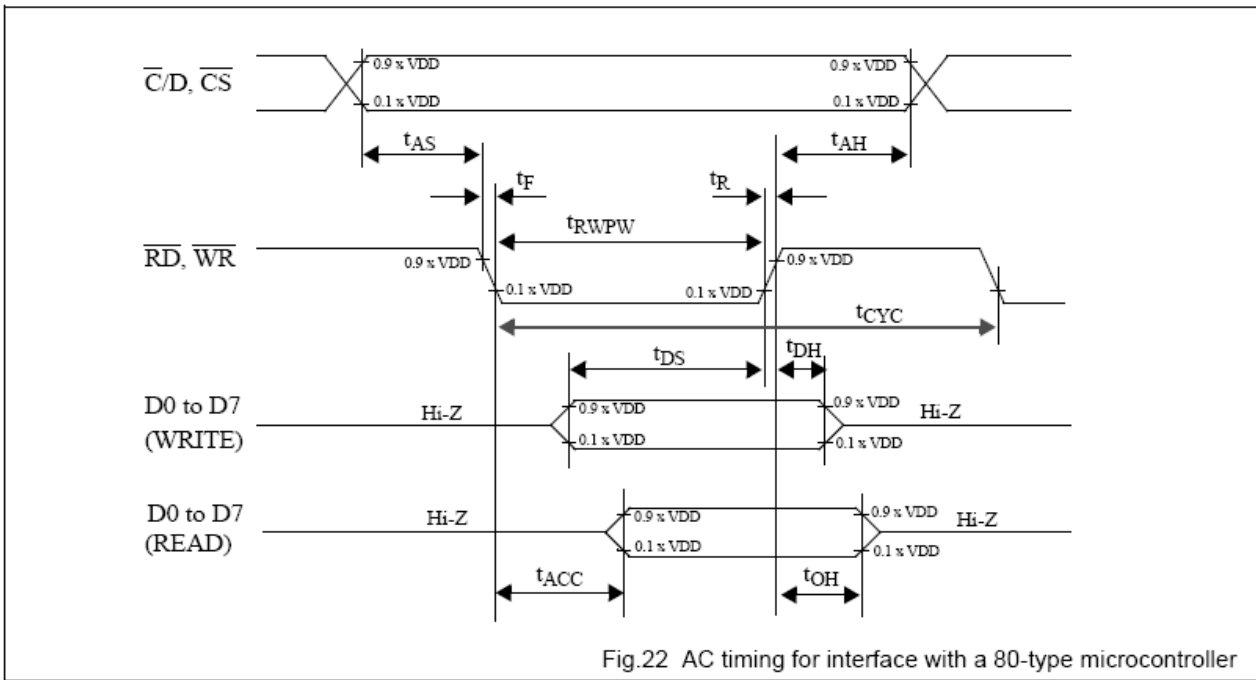

AC

timing for interface with a 80-type microcontroller at VDD=5 volts VDD = 5 V ±10%; VSS = 0 V; Tamb = -20 °C to +75°C.

symbol	parameter	min.	max.	test conditons	unit
t _{AS}	Address set-up time	20			ns
t _{AH}	Address hold time	10			ns
t _F , t _R	Read/Write pulse falling/rising time		15		ns
t _{RWPW}	Read/Write pulse width	200			ns
t _{CYC}	System cycle time	1000			ns
t _{DS}	Data setup time	80			ns
t _{DH}	Data hold time	10			ns
t _{ACC}	Data READ access time		90	CL= 100 pF.	ns
t _{OH}	Data READ output hold time	10	60	Refer to Fig. 23.	ns

AC timing for interface with an 80-type microcontroller at VDD=3 volts VDD = 3 V ±10%; VSS = 0 V; Tamb = -20 °C to +75°C.

symbol	parameter	min.	max.	test conditons	unit
t _{AS}	Address set-up time	40			ns
t _{AH}	Address hold time	20			ns
t _F , t _R	Read/Write pulse falling/rising time		15		ns
t _{RWPW}	Read/Write pulse width	400			ns
t _{CYC}	System cycle time	2000			ns
t _{DS}	Data setup time	160			ns

symbol	parameter	min.	max.	test conditons	unit
t_{DH}	Data hold time	20			ns
t_{ACC}	Data READ access time		180	$C_L = 100 \text{ pF}$,	ns
t_{OH}	Data READ output hold time	20	120	Refer to 23.	ns

Note:

The measurement is with the load circuit connected. The load circuit is shown in Fig. 23.

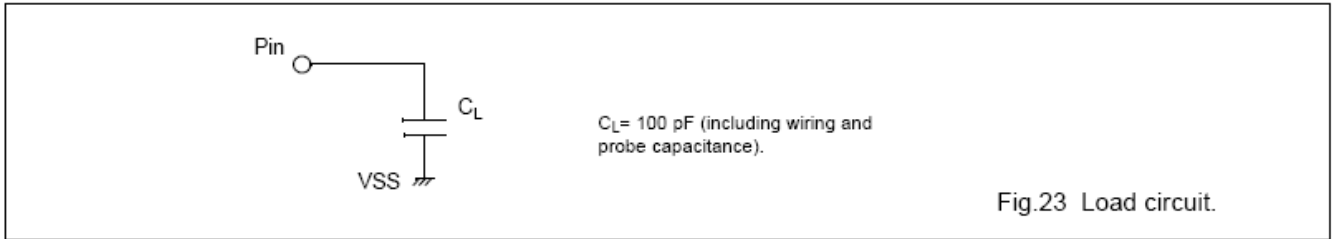

AC timing for interface with a 68-type microcontroller

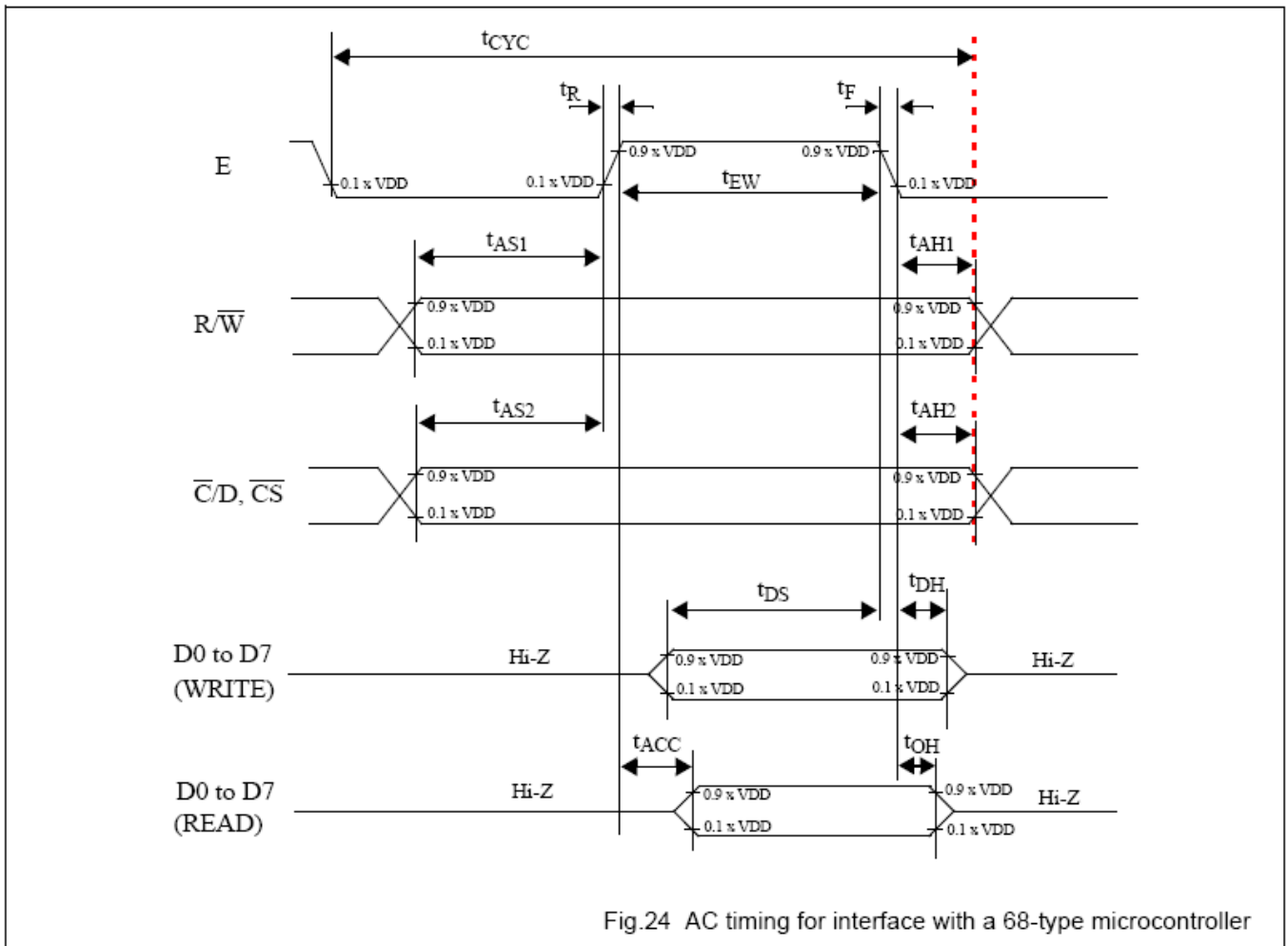

Fig.24 AC timing for interface with a 68-type microcontroller

AC timing for interface with a 68-type microcontroller at VDD=5 volts VDD = 5 V ±10%; VSS = 0 V;
Tamb = -20 °C to +75°C.

symbol	parameter	min.	max.	test conditons	unit
t _{AS1}	Address set-up time with respect to R/W	20			ns
t _{AS2}	Address set-up time with respect to $\overline{C/D}$, \overline{CS}	20			ns
t _{AH1}	Address hold time with respect to R/W	10			ns
t _{AH2}	Address hold time respect with to $\overline{C/D}$, \overline{CS}	10			ns
t _F , t _R	Enable (E) pulse falling/rising time		15		ns
t _{CYC}	System cycle time	1000		Note 1	ns
t _{EWR}	Enable pulse width for READ	100			ns
t _{EWV}	Enable pulse width for WRITE	80			ns
t _{DS}	Data setup time	80			ns
t _{DH}	Data hold time	10			ns
t _{ACC}	Data access time		90	CL= 100 pF.	ns
t _{OH}	Data output hold time	10	60	Refer to Fig. 23.	ns

AC timing for interface with a 68-type microcontroller at VDD=3 volts VDD = 3 V ±10%; VSS = 0 V;
Tamb = -20 °C to +75°C.

symbol	parameter	min.	max.	test conditons	unit
t _{AS1}	Address set-up time with respect to R/W	40			ns
t _{AS2}	Address set-up time with respect to $\overline{C/D}$, \overline{CS}	40			ns
t _{AH1}	Address hold time with respect to R/W	20			ns
t _{AH2}	Address hold time respect with to $\overline{C/D}$, \overline{CS}	20			ns
t _F , t _R	Enable (E) pulse falling/rising time		15		ns
t _{CYC}	System cycle time	2000		Note 1	ns
t _{EWR}	Enable pulse width for READ	200			ns
t _{EWV}	Enable pulse width for WRITE	160			ns
t _{DS}	Data setup time	160			ns
t _{DH}	Data hold time	20			ns
t _{ACC}	Data access time		180	CL= 100 pF.	ns
t _{OH}	Data output hold time	20	120	Refer to Fig. 23.	ns

Note:

1. The system cycle time(t_{CYC}) is the time duration from the time when Chip Enable is enabled to the time when Chip Select is released.

10. Function Description

◆Block Diagram

This 122×32 dots LCD Module built in two SBN1661G_M18-D LSI controller.

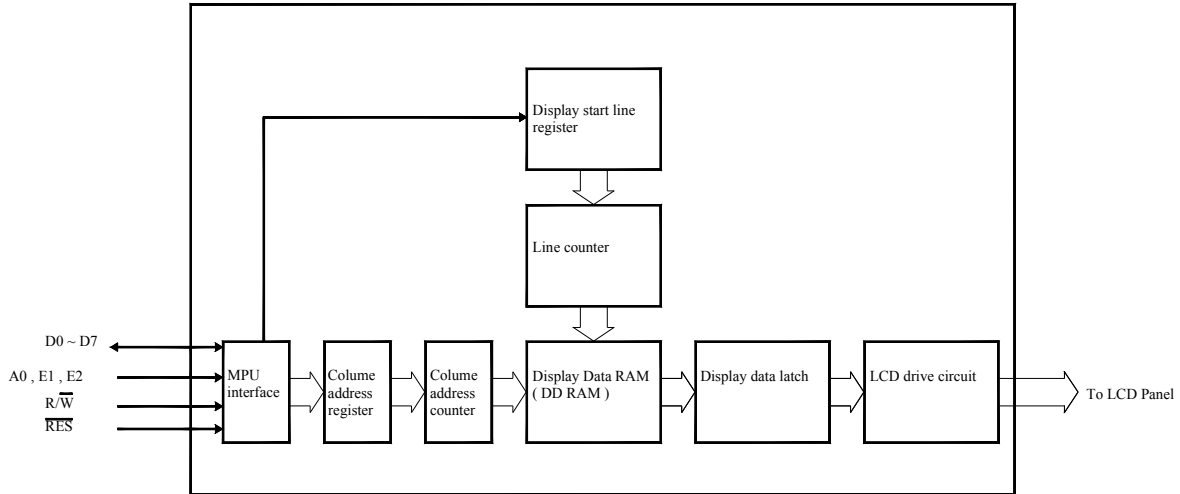

◆MPU interface

The SBN1661G_M18-D controller transfers data via 8-bit bidirectional data buses (D0 to D7), it can fit any MPU if it corresponds to SBN1661G_M18-D Read and Write Timing Characteristics.

◆Data transfer

The SBN1661G_M18-D driver uses the A0, E and R/W signals to transfer data between the system MPU and internal registers, The combinations used are given in the table below.

A0	R/W	Function
1	1	Read display data
1	0	Write display data
0	1	Read status
0	0	Write to internal register (command)

◆Busy flag

When the Busy flag is logical 1, the SBN1661G_M18-D series is executing its internal operations. Any command other than Status Read is rejected during this time. The Busy flag is output at pin D7 by the Status Read command. If an appropriate cycle time (t_{CYC}) is given, this flag needs not be checked at the beginning of each command and, therefore, the MPU processing capacity can greatly be enhanced.

◆Display Start Line and Line Count Registers

The contents of this register form a pointer to a line of data in display data RAM corresponding to the first line of the display (COM0), and are set by the Display Start Line command.

◆Column Address Counter

The column address counter is a 7-bit pre-settable counter that supplies the column address for MPU access to the display data RAM. See Figure 1. The counter is incremented by one every time the driver receives a Read or Write Display Data command. Addresses above 50H are invalid, and the counter will not increment past this value. The contents of the column address counter are set with the Set Column Address command.

◆Display Data RAM

The display data RAM stores the LCD display data, on a 1-bit per pixel basis. The relationship between display data, display address and the display is shown in Figure 1.

◆Page Register

The page register is a 2-bit register that supplies the page address for MPU access to the display data RAM. See Figure 1. The contents of the page register are set by the Set Page Register command.

11.Commands Descriptions

The host microcontroller can issue commands to the SBN1661G_X. Table 27 lists all the commands. When issuing a command, the host microcontroller should put the command code on the data bus. The host microcontroller should also give the control bus C/D, E(RD), and R/W(WR) proper value and timing.

Commands

COMMAND	COMMAND CODE								FUNCTION
	D7	D6	D5	D4	D3	D2	D1	D0	
Write Display Data	Data to be written into the Display Data Memory.								Write a byte of data to the Display Data Memory.
Read Display Data	Data read from the Display Data Memory.								Read a byte of data from the Display Data Memory.
Read-Modify-Write	1	1	1	0	0	0	0	0	Start Read-Modify-Write operation.
END	1	1	1	0	1	1	1	0	Stop Read-Modify-Write operation.
Software Reset	1	1	1	0	0	0	1	0	Software Reset.

Write Display Data

The Write Display Data command writes a byte (8 bits) of data to the Display Data Memory. Data is put on the data bus by the host microcontroller. The location which accepts this byte of data is pointed to by the Page Address Register and the Column Address Register. At the end of the command operation, the content of the Column Address Register is automatically incremented by 1.

The setting of the control bus for issuing Write Display Data command

$\overline{C/D}$	$E/(\overline{RD})$	$R/\overline{W}(\overline{WR})$
1	1	0

Read Display Data

The Read Display Data command starts a 3-step operation.

1. First, the current data of the internal 8-bit output latch of the Display Data Memory is read by the microcontroller, via the 8-bit data bus DB0~DB7.
2. Then, a byte of data of the Display Data Memory is transferred to the 8-bit output latch from a location specified by the Page Address Register and the Column Address Register,
3. Finally, the content of the Column Address Register is automatically incremented by one. Fig. 16 shows the internal 8-bit output latch located between the 8-bit I/O data bus and the Display Data Memory cell array. Because of this internal 8-bit output latch, a dummy read is needed to obtain correct data from the Display Data Memory. For Display Data Write operation, a dummy write **is not** needed, because data can be directly written from the data bus to internal memory cells.

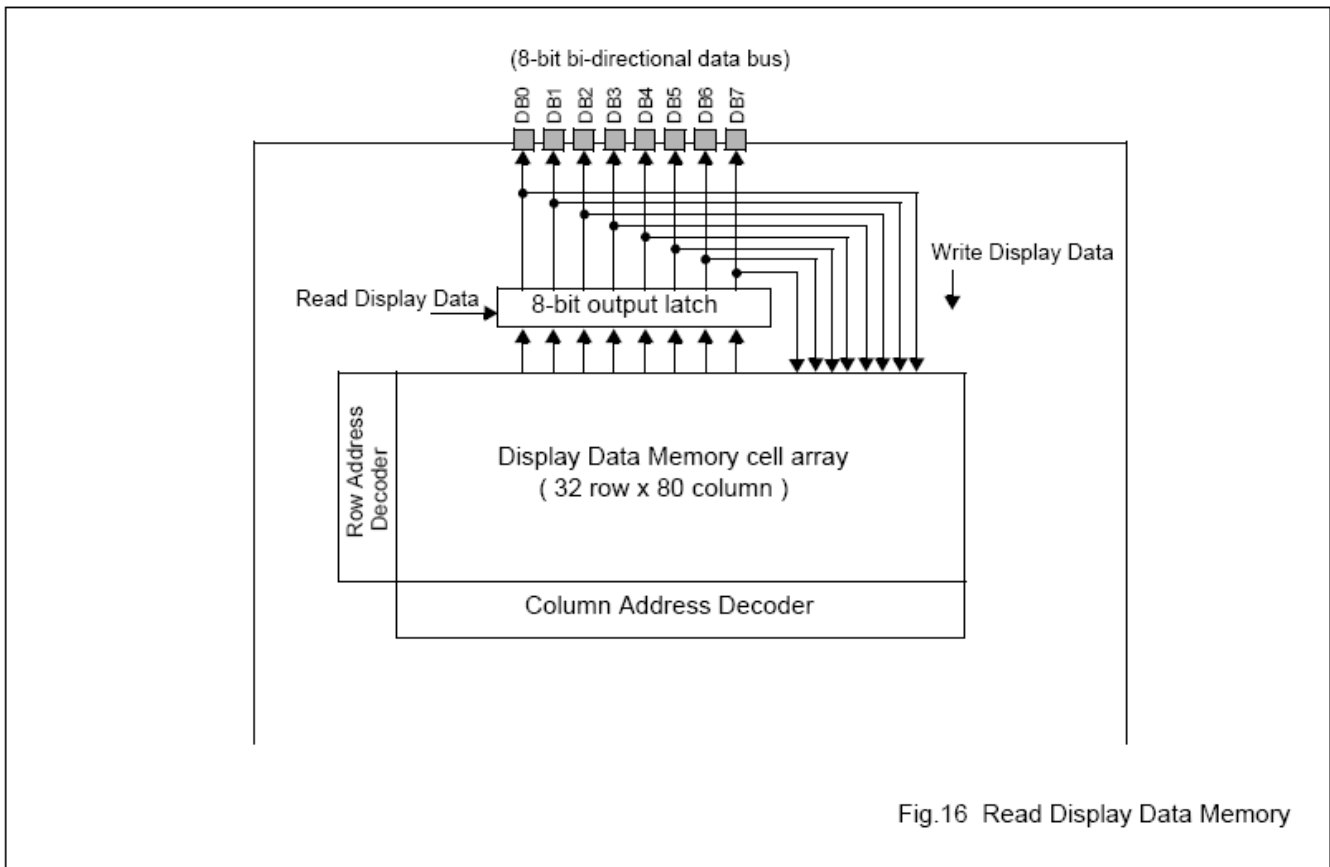

The setting of the control bus for issuing Read Display Data command

\overline{C}/D	$E/(\overline{RD})$	$R/\overline{W}(\overline{WR})$
1	0	1

Read-Modify-Write

When the Read-Modify-Write command is issued, the SBN1661G_X enters into Read-Modify-Write mode. In normal operation, when a Read Display Data command or a Write Display Data command is issued, the content of the Column Address Register is automatically incremented by one after the command operation is finished. However, during Read-Modify-Write mode, the content of the Column Address Register is not incremented by one after a Read Display Data command is finished; only the Write Display Data command can make the content of the Column Address Register automatically incremented by one after the command operation is finished.

During Read-Modify-Write mode, any other registers, except the Column Address Register, can be modified. This command is useful when a block of the Display Data Memory needs to be repeatedly read and updated.

Fig. 17 gives the change sequence of the Column Address Register during Read-Modify-Write mode.

Figure 18 gives the flow chart for Read-Modify-Write command.

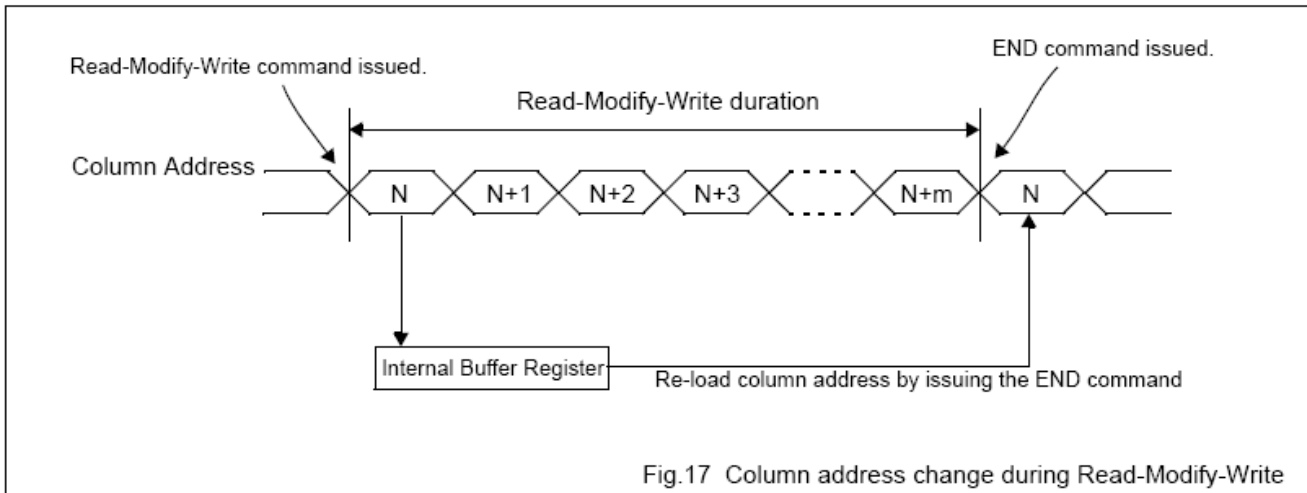

Fig.17 Column address change during Read-Modify-Write

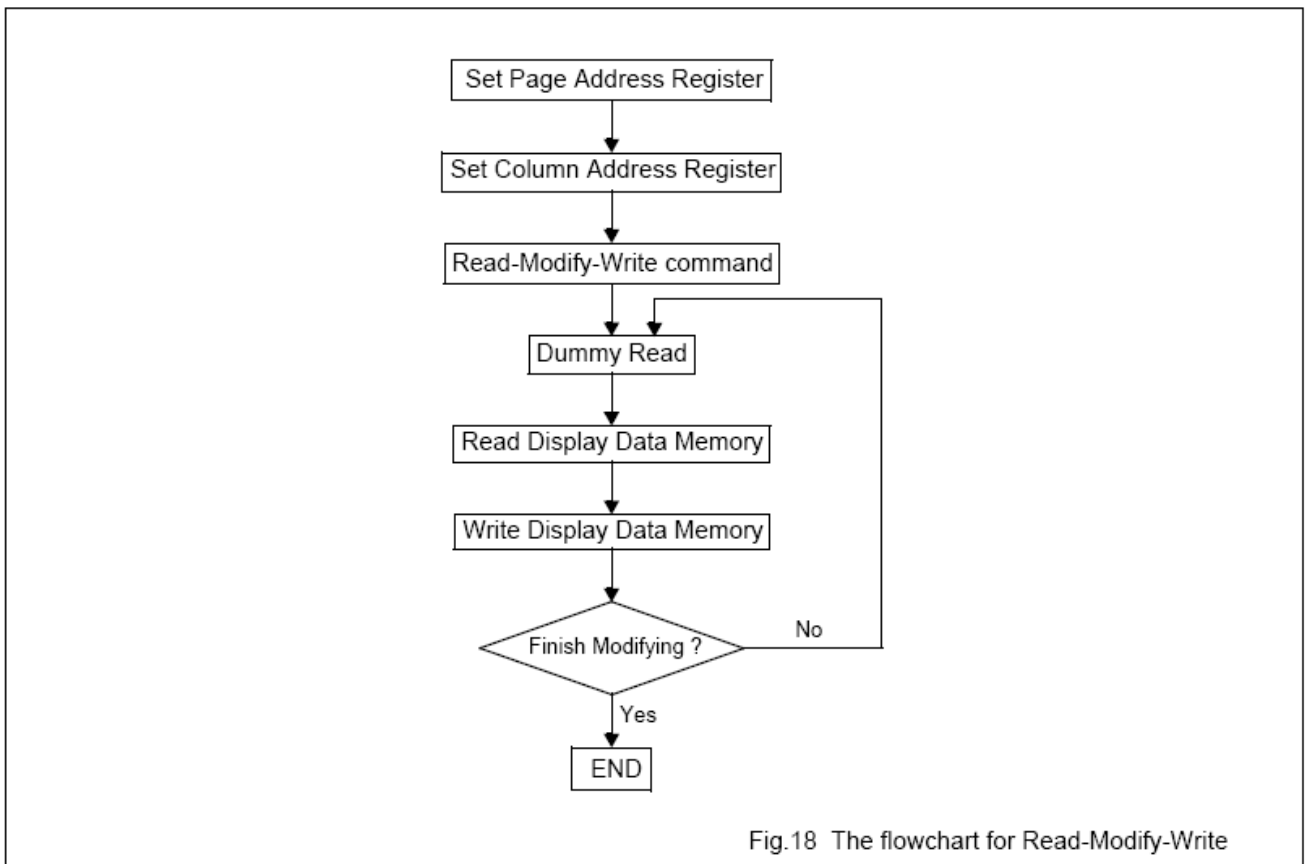

Fig.18 The flowchart for Read-Modify-Write

The setting of the control bus for the Read-Modify-Write command

$\overline{C/D}$	$E/(\overline{RD})$	$R/\overline{W}(\overline{WR})$
0	1	0

The setting of the data bus for the Read-Modify-Write command

D7(MSB)	D6	D5	D4	D3	D2	D1	D0(LSB)
1	1	1	0	0	0	0	0

The END command

The END command releases the Read-Modify-Write mode and re-loads the Column Address Register with the value previously stored in the internal buffer (refer to Fig. 17) when the Read-Modify-Write command was issued.

The setting of the control bus for the END command

\overline{C}/D	$E/(\overline{RD})$	$R/\overline{W}(\overline{WR})$
0	1	0

The setting of the data bus for the END command

D7(MSB)	D6	D5	D4	D3	D2	D1	D0(LSB)
1	1	1	0	1	1	1	0

The command code is EE Hex.

Software RESET command

The Software Reset command is different from the hardware reset and can not be used to replace hardware reset.

When Software Reset is issued by the host microcontroller,

- the content of the Display Start Line Register is cleared to zero(A4~A0=00000),
- the Page Address Register is set to 3 (A1 A0 = 11),
- the content of the Display Data Memory remains unchanged.
- the content of all other registers remains unchanged.

The setting of the control bus for Software RESET

\overline{C}/D	$E/(\overline{RD})$	$R/\overline{W}(\overline{WR})$
0	1	0

The setting of the data bus for Software RESET

D7(MSB)	D6	D5	D4	D3	D2	D1	D0(LSB)
1	1	1	0	0	0	1	0

The command code is E2 Hex.

12. Reliability

Content of Reliability Test (wide temperature, -20°C~70°C)

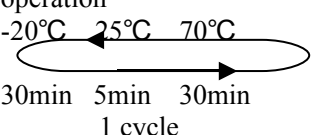
Environmental Test			
Test Item	Content of Test	Test Condition	Note
High Temperature storage	Endurance test applying the high storage temperature for a long time.	80°C 200hrs	2
Low Temperature storage	Endurance test applying the high storage temperature for a long time.	-30°C 200hrs	1,2
High Temperature Operation	Endurance test applying the electric stress (Voltage & Current) and the thermal stress to the element for a long time.	70°C 200hrs	—
Low Temperature Operation	Endurance test applying the electric stress under low temperature for a long time.	-20°C 200hrs	1
High Temperature/ Humidity Operation	The module should be allowed to stand at 60°C,90%RH max For 96hrs under no-load condition excluding the polarizer, Then taking it out and drying it at normal temperature.	60°C,90%RH 96hrs	1,2
Thermal shock resistance	The sample should be allowed stand the following 10 cycles of operation  -20°C 25°C 70°C 30min 5min 30min 1 cycle	-20°C/70°C 10 cycles	—
Vibration test	Endurance test applying the vibration during transportation and using.	Total fixed amplitude : 1.5mm Vibration Frequency : 10~55Hz One cycle 60 seconds to 3 directions of X,Y,Z for Each 15 minutes	3
Static electricity test	Endurance test applying the electric stress to the terminal.	VS=800V,RS=1.5kΩ CS=100pF 1 time	—

Note1: No dew condensation to be observed.

Note2: The function test shall be conducted after 4 hours storage at the normal Temperature and humidity after remove from the test chamber.

Note3: Vibration test will be conducted to the product itself without putting it in a container.

13. Backlight Information

PARAMETER	SYMBOL	MIN	TYP	MAX	UNIT	TEST CONDITION
Supply Current	I _{LED}	30	40	50	mA	V=3.5V
Supply Voltage	V	3.4	3.5	3.6	V	—
Reverse Voltage	V _R	—	—	5	V	—
Luminous Intensity	I _V	120	150	—	CD/M ²	I _{LED} =40mA
Wave Length	λ _p	—	—	—	nm	I _{LED} =40mA
Life Time	—	—	10k	—	Hr.	I _{LED} ≤ 40mA
Color	White 2 DICE					

Note: The LED of B/L is drive by current only, drive voltage is for reference only.
 drive voltage can make driving current under safety area (current between minimum and maximum).

LED B\L Drive Method
 Drive from A , K

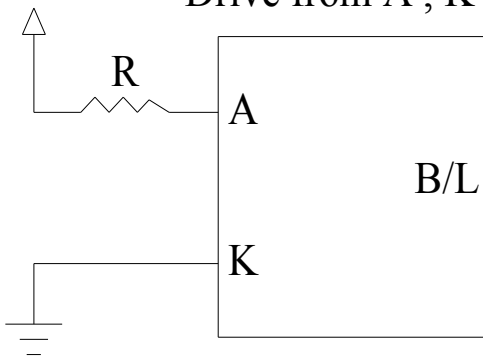

14. Material List of Components for RoHS

1. Crystalfontz America, Inc. hereby declares that all of or part of products (with the mark “#”in code), including, but not limited to, the LCM, accessories or packages, manufactured and/or delivered to your company (including your subsidiaries and affiliated company) directly or indirectly by our company (including our subsidiaries or affiliated companies) do not intentionally contain any of the substances listed in all applicable EU directives and regulations, including the following substances.

Exhibit A: The Harmful Material List

Material	(Cd)	(Pb)	(Hg)	(Cr6+)	PBBs	PBDEs
Limited Value	100 ppm	1000 ppm	1000 ppm	1000 ppm	1000 ppm	1000 ppm
Above limited value is set up according to RoHS.						

2. Process for RoHS requirement:

(1) Use the Sn/Ag/Cu soldering surface ; the surface of Pb-free solder is rougher than we used before.

(2) Heat-resistance temp.

Reflow: 250°C, 30 seconds Max.

Connector soldering wave or hand soldering: 320°C, 10 seconds max.

(3) Temp. curve of reflow, max. Temp.: 235±5°C

Recommended customer’s soldering temp. of connector: 280°C, 3 seconds.