



CrystalFontz America, Incorporated

GRAPHIC OLED MODULE SPECIFICATIONS



CrystalFontz Model Number	CFAL12864S-Y-B1
Hardware Version	Version A, February 2009
Data Sheet Version	Version 1.1, December 2009
Product Pages	www.crystalfontz.com/product/CFAL12864SYB1.html

CrystalFontz America, Incorporated

12412 East Saltese Avenue
Spokane Valley, WA 99216-0357

Phone: 888-206-9720

Fax: 509-892-1203

Email: techinfo@crystalfontz.com

URL: www.crystalfontz.com



REVISION HISTORY

HARDWARE	
2009/02/18	Current hardware version: vA

DATA SHEET	
2009/12/21	<p>Current Data Sheet version: 1.1 Changes since last Data Sheet (v1.0):</p> <ul style="list-style-type: none"> ● Wherever listed, corrected specification of overall module maximum depth from “0.08” to “0.09” inches. Module dimensions did not change. ● Minor changes for pin names in Details of Interface Pin Function (Pg. 17). Pins have not changed. ● Corrected mention of “TFT” to “OLED” in APPENDIX C: OLED MODULE TERMS AND SYMBOLS (Pg. 33).
2009/11/25	<p>Data Sheet version: 1.0 Since last Data Sheet (no version number, Preliminary):</p> <ul style="list-style-type: none"> ● Moved specifications into standard Graphic OLED template. ● In Physical Characteristics (Pg. 8) (previously “General Specifications”): <ul style="list-style-type: none"> - In addition to dimension for overall module height of “56.6” millimeters with FPC <i>unfolded</i>, added height of “39.44” millimeters with FPC <i>folded</i>. - In addition to <i>nominal</i> module depth of “2.01” millimeters, added <i>maximum</i> depth of “2.21” millimeters. - Added specifications for “Diagonal”, “Module Connector Pitch”, and “Weight”. ● In Absolute Maximum Ratings (Pg. 15), <ul style="list-style-type: none"> - Changed “Logic Supply Voltage” (formerly “Supply Voltage”) from minimum of “+2.4” to “-0.3v”. ● In DC Characteristics (Pg. 16) (formerly Electrical Characteristics), expanded and clarified specifications. Also corrected “OLED Driver Supply Voltage” specifications: <ul style="list-style-type: none"> - Minimum from “2.4v” to “+12.5v”. - Typical from “2.7v” to “+13v”. - Maximum from “3.5v” to “+13.5v”. ● In Details of Interface Pin Function (Pg. 17), used CrystalFontz standard terms for signals and improved descriptions. ● In Optical Characteristics (Pg. 21), added “Yellow Chromaticity” specification. ● In CARE AND HANDLING PRECAUTIONS (Pg. 24) (formerly “Precautions in use of OLED Modules”, expanded information with important advice on design, hot bar soldering, and cleaning.
Continued on next page.	



DATA SHEET	
2009/11/25	<ul style="list-style-type: none">● Improved illustrations, including:<ul style="list-style-type: none">- More details in Module Outline Drawings (Pg. 9).- More details in System Block Diagram (Pg. 12).- New Application Circuit Example (Pg. 13).- New Circuit Example – Externally Supplied for Display (Pg. 14) using Micrel MIC2290 for V_{PANEL}.- Added illustration to explain Power Up and Power Down Sequencing (Pg. 14).- Added photo with pins labeled (see Photo Reference for Pin Functions (Pg. 20)).- Added illustration for “Definition of Viewing Angle” in OPTICAL SPECIFICATIONS (Pg. 21).● Added new sections, including:<ul style="list-style-type: none">- MAIN FEATURES (Pg. 6).- ESD (Electro-Static Discharge) (Pg. 20).- MODULE RELIABILITY AND LONGEVITY (Pg. 23).- APPENDIX A: QUALITY ASSURANCE STANDARDS (Pg. 27).- APPENDIX B: SAMPLE CODE (Pg. 30).- APPENDIX C: OLED MODULE TERMS AND SYMBOLS (Pg. 33).- APPENDIX D: SOLOMON SYSTECH 1303 CONTROLLER SPECIFICATION SHEET (Pg. 38).● Deleted information that is repeated in the appended controller specifications.● This module can be ordered as part of a CFA10009 demonstration board kit. The <i>CFA10009 User Guide</i> was added at the end of this Data Sheet.
2009/02/18	Data Sheet version: No version number (unmarked Preliminary) New Data Sheet.



The Fine Print

Certain applications using CrystalFontz America, Inc. products may involve potential risks of death, personal injury, or severe property or environmental damage ("Critical Applications"). CRYSTALFONTZ AMERICA, INC. PRODUCTS ARE NOT DESIGNED, INTENDED, AUTHORIZED, OR WARRANTED TO BE SUITABLE FOR USE IN LIFE-SUPPORT APPLICATIONS, DEVICES OR SYSTEMS OR OTHER CRITICAL APPLICATIONS. Inclusion of CrystalFontz America, Inc. products in such applications is understood to be fully at the risk of the customer. In order to minimize risks associated with customer applications, adequate design and operating safeguards should be provided by the customer to minimize inherent or procedural hazard. Please contact us if you have any questions concerning potential risk applications.

CrystalFontz America, Inc. assumes no liability for applications assistance, customer product design, software performance, or infringements of patents or services described herein. Nor does CrystalFontz America, Inc. warrant or represent that any license, either express or implied, is granted under any patent right, copyright, or other intellectual property right of CrystalFontz America, Inc. covering or relating to any combination, machine, or process in which our products or services might be or are used.

The information in this publication is deemed accurate but is not guaranteed.

Company and product names mentioned in this publication are trademarks or registered trademarks of their respective owners.

Copyright © 2009 by CrystalFontz America, Inc., 12412 East Saltese Avenue, Spokane Valley, WA 99216-0357 U.S.A.



CONTENTS

MAIN FEATURES	6
Demonstration and Evaluation Platform	6
Comparison to LCD (Liquid Crystal Display) Module	6
Features	6
Module Classification Information	7
MECHANICAL SPECIFICATIONS	8
Physical Characteristics	8
Module Outline Drawings	9
ELECTRICAL SPECIFICATIONS	12
System Block Diagram	12
Application Circuit Example	13
Circuit Example – Externally Supplied for Display	14
Power Up and Power Down Sequencing	14
Absolute Maximum Ratings	15
DC Characteristics	16
Details of Interface Pin Function	17
Photo Reference for Pin Functions	20
ESD (Electro-Static Discharge)	20
OPTICAL SPECIFICATIONS	21
Optical Characteristics	21
OLED CONTROLLER INTERFACE	22
MODULE RELIABILITY AND LONGEVITY	23
Module Reliability	23
Module Longevity (EOL/Replacement Policy)	23
CARE AND HANDLING PRECAUTIONS	24
APPENDIX A: QUALITY ASSURANCE STANDARDS	27
APPENDIX B: SAMPLE CODE	30
Sources For Driver Libraries	30
Sample Code	30
APPENDIX C: OLED MODULE TERMS AND SYMBOLS	33
APPENDIX D: SOLOMON SYSTECH 1303 CONTROLLER SPECIFICATION SHEET	38

LIST OF FIGURES

Figure 1. Module Outline Drawings (3 pages below)	9
Figure 2. System Block Diagram	12
Figure 3. Application Circuit Example	13
Figure 4. Circuit Example – External Supply for Display	14
Figure 5. Power Up and Power Down Sequencing	14
Figure 6. Front View of Unfolded FPC, Pins Labeled	20
Figure 7. CFAL12864S-Y-B1 has a 160° Viewing Angle	22
Figure 8. Typical Tab Solder Tail Construction	25



MAIN FEATURES

DEMONSTRATION AND EVALUATION PLATFORM

This module is available installed on a CrystalFontz CFA-10009 Demonstration PCB. The [DMO-L12864SYB1](#) kit has everything you need to easily demonstrate and experiment with the module. The kit can also be used as a reference for your designs. The *CFA10009 User Guide* can be found at the end of this Data Sheet.

COMPARISON TO LCD (LIQUID CRYSTAL DISPLAY) MODULE

The CFAL12864S-Y-B1 is a monochrome 128 x 64 dot matrix Organic Light-Emitting Diode (OLED) display module. The small size, and ultrathin form factor of the CFAL12864S-Y-B1 makes it possible to use this OLED module in applications where it would be difficult or impossible to fit a traditional monochrome LCD module. Because of the low power requirements, the CFAL12864S-Y-B1 is suitable in battery powered portable devices such as remote controls and scientific meters (for example, temperature, sound, and gas detection).

Compared to most LCD modules, this OLED module has a quicker response time and an extremely wide viewing angle. At the low end of an STN LCD's temperature range, a module's contrast will typically be poor and the response time will be very slow. Unlike an STN LCD module, contrast does not diminish and response time is good at the lower end of an OLED module's operating temperature range, allowing it to operate in cold environments without a heater.

FEATURES

- 128 x 64 module consists of an OLED panel, and an FPC (Flexible Printed Circuit) tail with a COF (Chip on Flex) driver IC.
- Module Dimensions:
 - Active Area is 2.42" diagonal, 55.01 (W) x 27.49 (H) millimeters (2.17" (W) x 1.08" (H)).
 - Overall module dimension with FPC *unfolded* is 60.51 (W) x 56.60 (H) x 2.21 maximum (D) millimeters (2.38" (W) x 2.23" (H) x 0.09" maximum (D)).
 - Overall module dimension with FPC *folded* is 60.51 (W) x 39.44 (H) x 2.21 maximum (D) millimeters (2.38" (W) x 1.55" (H) x 0.09" maximum (D)).
- Requires 3v for logic and a separate supply for V_{PANEL} .
- 8-bit parallel (8080 or 6800) interface or Serial Peripheral Interface (SPI).
- [Solomon Systech SSD1303](#) or compatible controller.
- Emissive monochrome display. Display yellow pixels on dark area or dark pixels on yellow area (if operating with display pixels reversed/inverted).
- Very high contrast ratio.
- Extremely wide viewing angle is $>160^\circ$.
- Wide temperature range for operation is -20°C to $+70^\circ\text{C}$.
- RoHS compliant.



MODULE CLASSIFICATION INFORMATION

CFA L 128 64 S - Y - B1
① ② ③ ④ ⑤ ⑥ ⑦

①	Brand	CrystalFontz America, Inc.
②	Display Type	L – OLED
③	Number of Pixels (Width)	128 pixels
④	Number of Pixels (Height)	64 pixels
⑤	Model Identifier	S
⑥	Display Color	Y – Yellow
⑦	Special Code 1	B1 – Manufacturer's code



MECHANICAL SPECIFICATIONS

PHYSICAL CHARACTERISTICS

ITEM	SIZE
Pixels	
Number of Pixels	128 x 64 pixels = 8,192 pixels
Pixel Size	0.40 (W) x 0.40 (H) mm
Pixel Pitch	0.43 (W) x 0.43 (H) mm
Viewing Area Width and Height	Millimeters: 57.01 (W) x 29.49 (H) mm Inches: 2.24" (W) x 1.16" (H)
Active Area	
Diagonal	Inches: 2.42"
Width and Height	Millimeters: 55.01 (W) x 27.49 (H) mm Inches: 2.17" (W) x 1.08" (H)
Overall Module Outline Dimensions	
Width	Millimeters: 60.51 mm Inches: 2.38"
Height with module FPC unfolded	Millimeters: 56.60 mm Inches: 2.23"
Height with module FPC folded	Millimeters: 39.44 mm Inches: 1.55"
Module Depth	Maximum: Millimeters: 2.21 mm Inches: 0.09" Nominal: Millimeters: 2.01 mm Inches: 0.08"
Module Connector Pitch	0.8 mm
Aperture Rate*	86%
Weight	10 grams (typical)
<i>*Aperture rate is defined by dividing an effective display area with unit pixel area.</i>	



MODULE OUTLINE DRAWINGS

Figure 1. Module Outline Drawings (3 pages below)

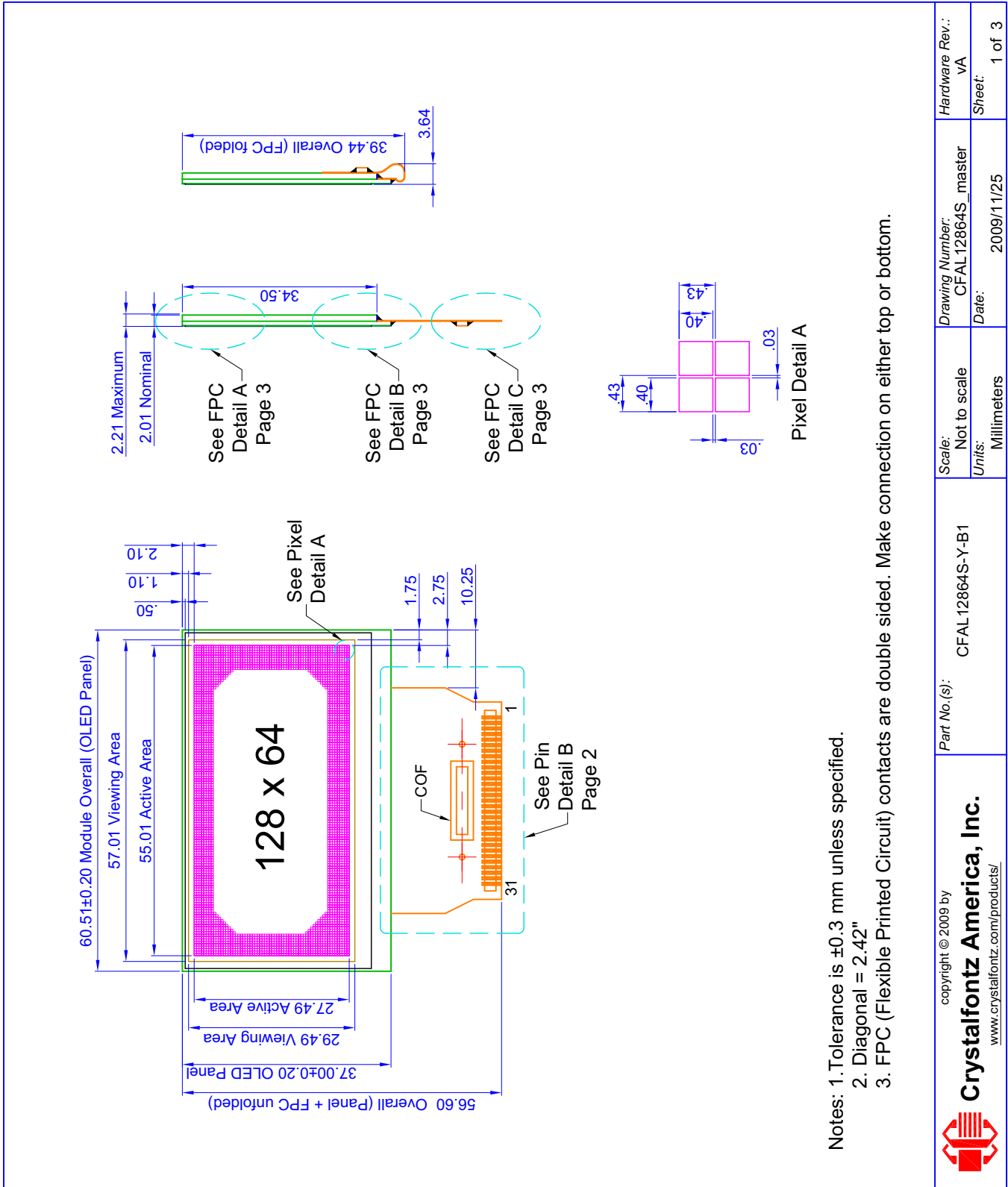

Notes: 1. Tolerance is ±0.3 mm unless specified.
 2. Diagonal = 2.42"
 3. FPC (Flexible Printed Circuit) contacts are double sided. Make connection on either top or bottom.

Scale:	Not to scale	Drawing Number:	CFAL12864S_master	Hardware Rev.:	vA
Units:	Millimeters	Date:	2009/11/25	Sheet:	1 of 3
Part No.(s):	CFAL12864S-Y-B1				
copyright © 2009 by Crystalfontz America, Inc. www.crystalfontz.com/products/					

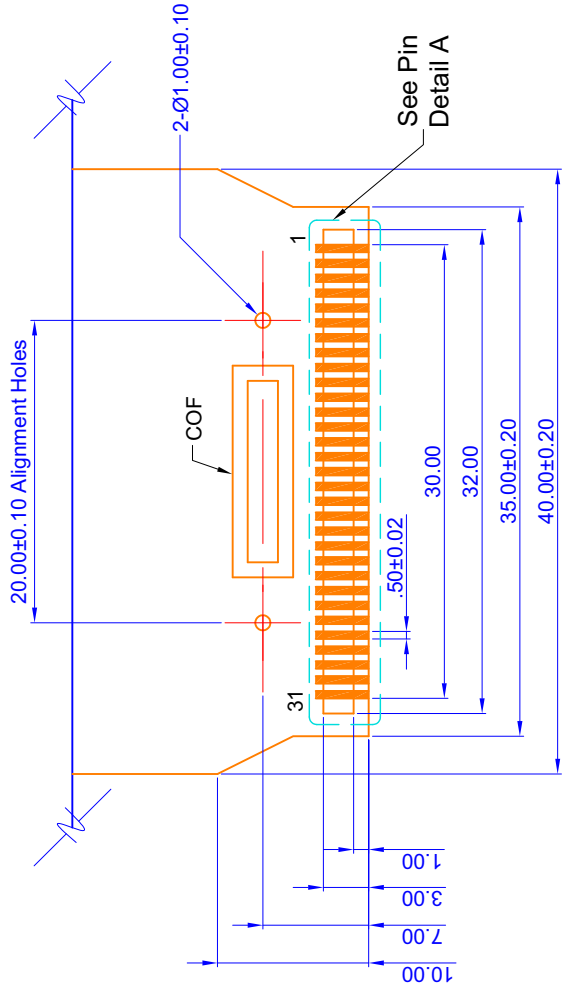

(B) Pin Detail

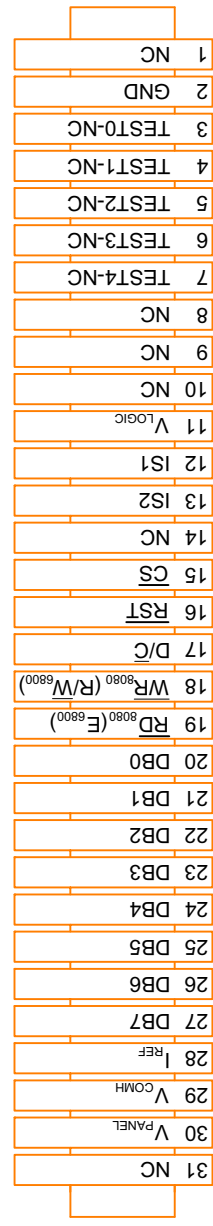

Pin Detail A
 Front View, FPC unfolded

- Notes: 1. Tolerance is ± 0.3 mm unless specified.
 2. Diagonal = 2.42"
 3. FPC (Flexible Printed Circuit) contacts are double sided. Make connection on either top or bottom.

 CrystalFontz America, Inc. www.crystalfontz.com/products/	Part No.(s):	CFAL12864S-Y-B1	Scale:	Not to scale	Drawing Number:	CFAL12864S_master	Hardware Rev.:	vA
	copyright © 2009 by	Units:	Millimeters	Date:	2009/11/25	Sheet:	2 of 3	

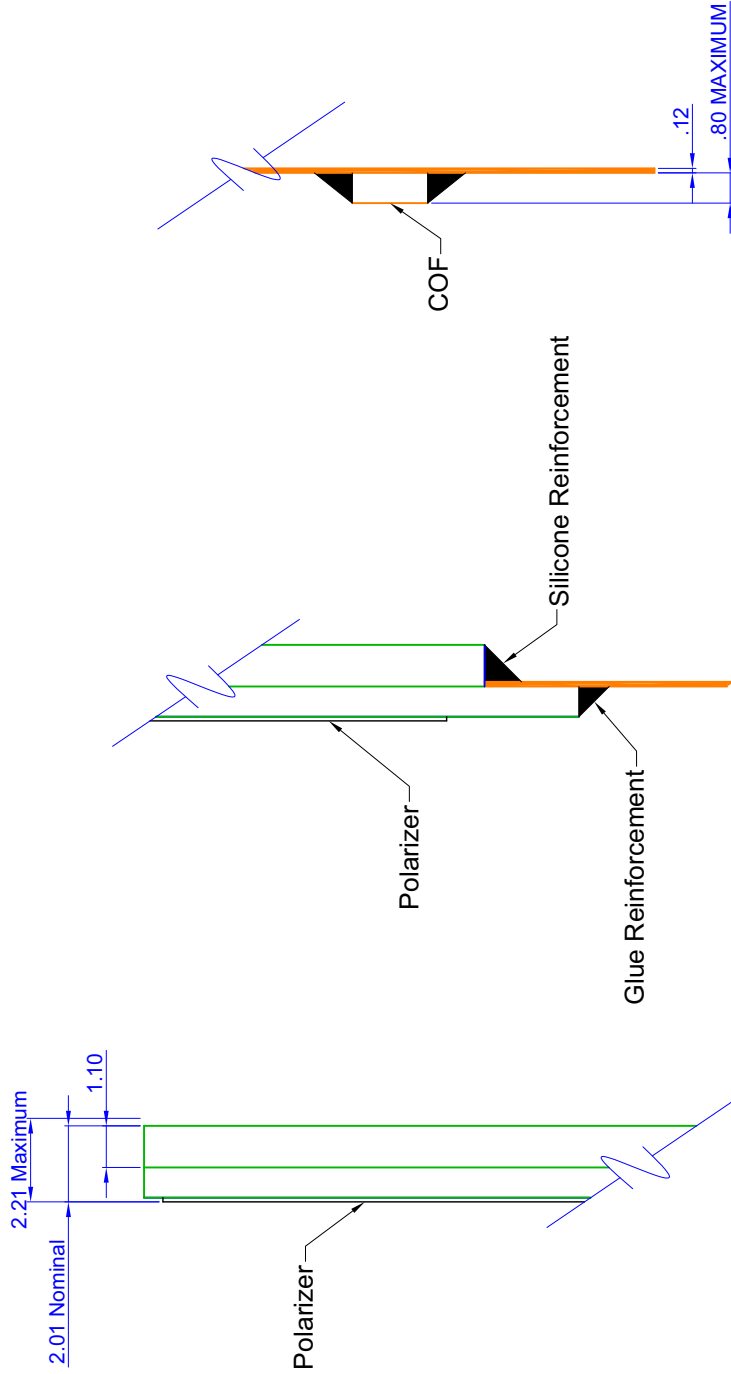

(A) FPC Detail

(B) FPC Detail

(C) FPC Detail

- Notes: 1. Tolerance is ± 0.3 mm unless specified.
 2. Diagonal = 2.42"
 3. FPC (Flexible Printed Circuit) contacts are double sided. Make connection on either top or bottom.

copyright © 2009 by CrystalFontz America, Inc. www.crystalfontz.com/products/		Part No. (s): CFAL12864S-Y-B1	Scale: Not to scale Units: Millimeters	Drawing Number: CFAL12864S_master Date: 2009/11/25	Hardware Rev.: vA Sheet: 3 of 3
------------------------------------------------------------------------------------------------------------------------------------------------	--	-----------------------------------------	-------------------------------------------------	--------------------------------------------------------------------	------------------------------------------



ELECTRICAL SPECIFICATIONS

SYSTEM BLOCK DIAGRAM

Note: FPC contacts are double sided. Make connection on either top or bottom.
From front view, pin order is reverse of typical: left to right is 31 to 1.

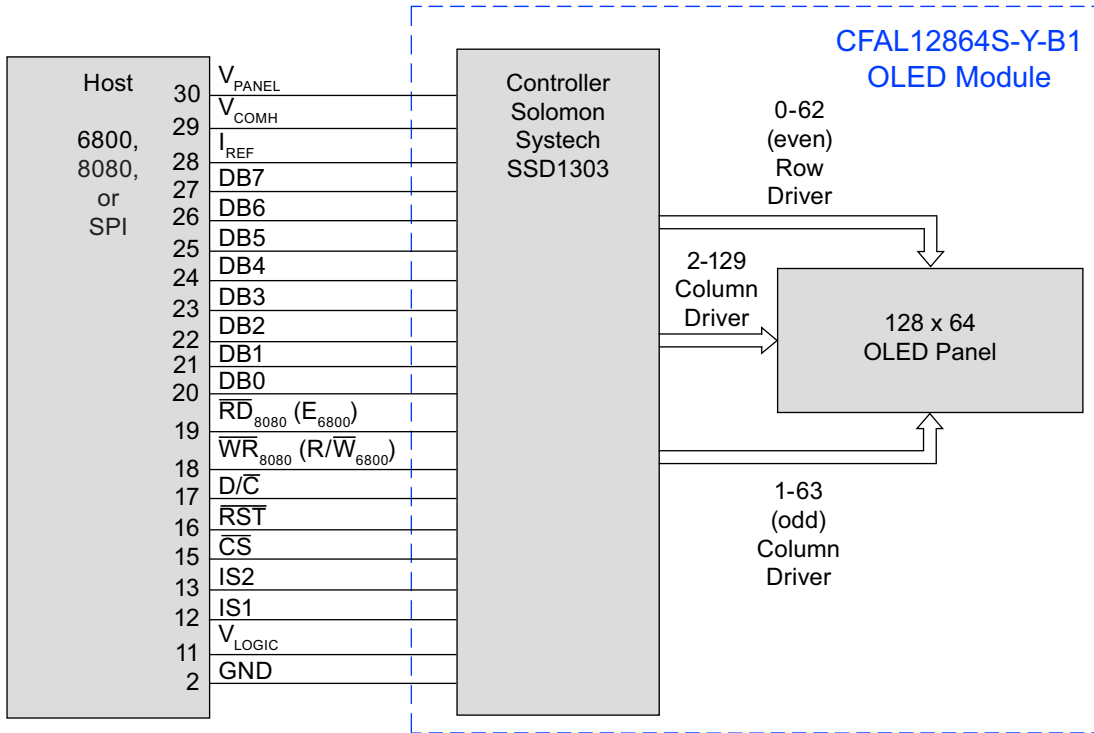

Figure 2. System Block Diagram



APPLICATION CIRCUIT EXAMPLE

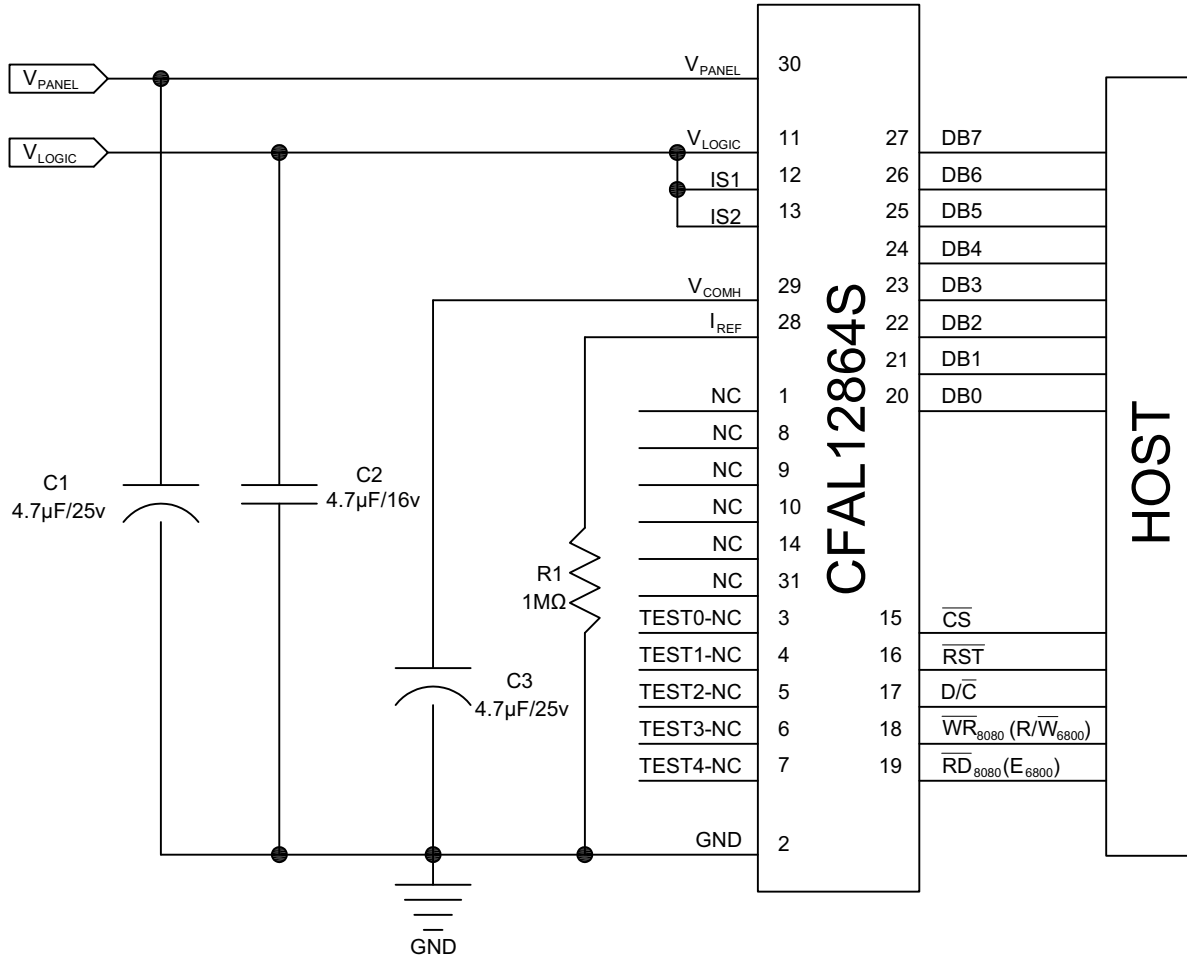

Figure 3. Application Circuit Example



CIRCUIT EXAMPLE – EXTERNALLY SUPPLIED FOR DISPLAY

The [Micrel MIC2290](#) is one of many possible V_{PANEL} supply solutions.

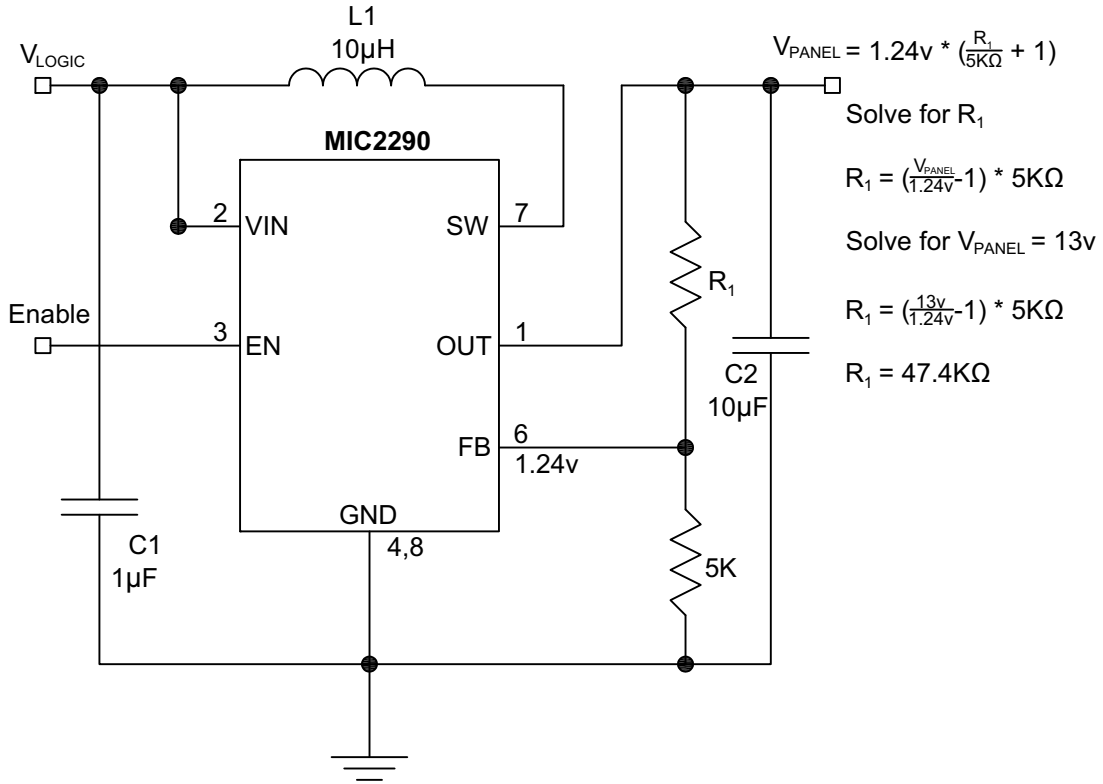

Figure 4. Circuit Example – External Supply for Display

Please refer to the Micrel MIC2290 datasheet for design details. See <http://micrel.com/page.do?page=/product-info/products/mic2290.shtml>.

POWER UP AND POWER DOWN SEQUENCING

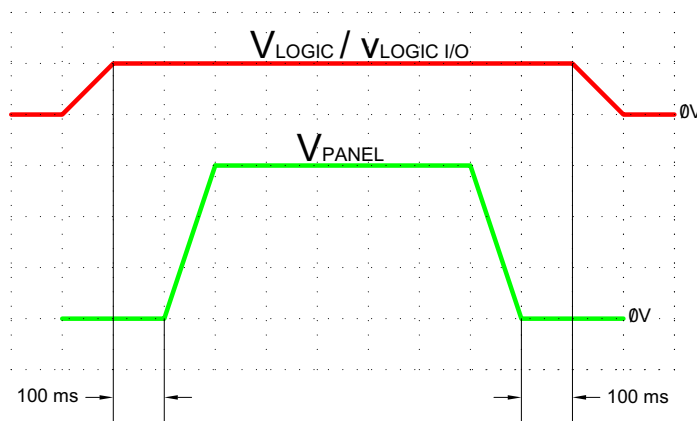

Figure 5. Power Up and Power Down Sequencing



ABSOLUTE MAXIMUM RATINGS

Ambient Temperature (Ta) = 25°C, Maximum 50% Relative Humidity			
ABSOLUTE MAXIMUM RATINGS	SYMBOL	MINIMUM	MAXIMUM
Operating Temperature*	T _{OP}	-20°C	+70°C
Storage Temperature*	T _{ST}	-30°C	+80°C
Humidity	RH	0%	90%
Logic Supply Voltage	V _{LOGIC}	-0.3v	+3.5v
OLED Driver Supply Voltage	V _{PANEL}	+8v	+16v
<i>*Prolonged exposure at temperatures outside of this range may cause permanent damage to the module or decrease product lifetime.</i>			



DC CHARACTERISTICS

DC CHARACTERISTICS	TEST CONDITION	SYMBOL	MINIMUM	TYPICAL	MAXIMUM
Logic Supply Voltage	T _{OP} = -20°C to +70°C	V _{LOGIC}	+2.4v	+2.7v	+3.5v ¹
OLED Driver Supply Voltage ²	T _{OP} = -20°C to +70°C	V _{PANEL}	+12.5v	+13v	+13.5v
Input High Voltage		V _{IH}	+0.8v x V _{LOGIC} For V _{LOGIC} = +2.7v V _{IH} = +0.8v x +2.7v = +2.16v		V _{LOGIC}
Input Low Voltage		V _{IL}	0v (GND)		+0.2v x V _{LOGIC} For V _{LOGIC} = +2.7v V _{IL} = +0.2v x +2.7v = +0.54v
Output High Voltage	I _{OUT} = 100µA 3.3MHz	V _{OH}	+0.9v x V _{LOGIC} For V _{LOGIC} = +2.7v V _{OH} = +0.9v x +2.7v = +2.43v		V _{LOGIC}
Output Low Voltage	I _{OUT} = 100µA 3.3MHz	V _{OL}	0v (GND)		+0.1v x V _{LOGIC} For V _{LOGIC} = +2.7v V _{OL} = +0.1v x +2.7v = +0.27v
Normal Mode Power Consumption	All pixels on V _{LOGIC} = +2.7v V _{PANEL} = +13v Frame Rate = 105 Hz Contrast Setting = 0x8F	P _{OPERATION}			400 mW
Standby Mode Power Consumption	10% pixels on V _{LOGIC} = +2.7v V _{PANEL} = +13v Frame Rate = 105 Hz Contrast Setting = 0x00	P _{STANDBY}			45 mW
Operating Current for V _{LOGIC}	Contrast = 0xFF	I _{LOGIC}	190µA		300 µA
Operating Current for V _{PANEL}	Contrast = 0xFF	I _{PANEL}	550µA		1,000 µA

¹Do not exceed +3.5v maximum.

²The V_{PANEL} input must be a stable value with no ripple or noise.

This is a summary of the module's major operating parameters. For detailed information see [APPENDIX D: SOLOMON SYSTECH 1303 CONTROLLER SPECIFICATION SHEET \(Pg. 38\)](#).



DETAILS OF INTERFACE PIN FUNCTION

*Note: FPC contacts are double sided. Make connection on either top or bottom.
 From front view, pin order is reverse of typical: left to right is 31 to 1.*

PIN	SIGNAL	LEVEL	DIRECTION	DESCRIPTION															
1	NC			No connection.															
2	GND	0v		Ground. Must be connected to an external ground.															
3-7	Test-NC			No Connection. Reserved for manufacturer testing.															
8-10	NC			No Connection.															
11	V _{LOGIC}	+ 2.4v to +3.5v	I	Power supply input. Must be connected to an external source.															
12	IS1	H/L	I	<table border="1"> <thead> <tr> <th>IS1</th> <th>IS2</th> <th>Interface Mode</th> </tr> </thead> <tbody> <tr> <td>0</td> <td>0</td> <td>SPI (Serial)</td> </tr> <tr> <td>0</td> <td>1</td> <td>6800 Parallel</td> </tr> <tr> <td>1</td> <td>0</td> <td>Not Allowed</td> </tr> <tr> <td>1</td> <td>1</td> <td>8080 Parallel</td> </tr> </tbody> </table>	IS1	IS2	Interface Mode	0	0	SPI (Serial)	0	1	6800 Parallel	1	0	Not Allowed	1	1	8080 Parallel
IS1	IS2	Interface Mode																	
0	0	SPI (Serial)																	
0	1	6800 Parallel																	
1	0	Not Allowed																	
1	1	8080 Parallel																	
13	IS2	H/L	I																
14	NC			No Connection.															
15	\overline{CS}	H/L	I	<p>Chip select input.</p> <p><i>Low:</i> Controller chip is selected. Communications with the host is possible.</p> <p><i>High:</i> Controller chip is not selected. Host interface signals are ignored by the controller.</p>															
16	\overline{RST}	H/L	I	<p>Reset signal.</p> <p><i>Low:</i> Display controller is reset. The \overline{RST} pin should be pulsed low shortly after power is applied.</p> <p><i>High:</i> The \overline{RST} pin should be brought high for normal operation.</p>															
17	D/ \overline{C}	H/L	I	<p>Data/Command control. Determines whether data bits are data or command.</p> <p><i>1 – High:</i> Addresses the data register.</p> <p><i>2 – Low:</i> Addresses the command register.</p>															



PIN	SIGNAL	LEVEL	DIRECTION	DESCRIPTION
18	\overline{WR}_{8080} (R/\overline{W}_{6800})	H/L	I	Host interface input. <i>8080 Host:</i> Active low. Signal on the databus is latched at the rising edge of WR signal. <i>6800 Host:</i> read/write control signal output. $R/\overline{W} = High$: Read (Host←Module) $R/\overline{W} = Low$: Write (Host→Module) <i>SPI (serial) mode:</i> Connect to ground.
19	\overline{RD}_{8080} (E_{6800})	H/L	I	Host interface input. <i>8080 Host:</i> Active low. Signal on the databus is latched at the rising edge of RD signal. <i>6800 Host:</i> Enable control signal input active high. $E = High$: Read or Write Active $E = Low$: No Read or Write Active <i>SPI (serial) mode:</i> Connect to ground.
20	DB0	H/L	I/O	Bidirectional databus connects to 8-bit standard host databus. <i>In SPI (serial) mode (IS1=0, IS2=0):</i> DB0 serves as the serial clock input signal (SCL) and DB1 serves as the serial data input pin (SI). DB2-DB7 are high impedance. In serial mode, data can be written to the display but not read. Pin 18 (\overline{WR}_{8080} (R/\overline{W}_{6800})) and pin 19 (\overline{RD}_{8080} (E_{6800})) are unused and should be tied low. <i>In 6800 Parallel mode:</i> Pin 18 is used as R/\overline{W}_{6800} . Pin 19 is used as E_{6800} . Data is input or output on DB0-DB7. <i>In 8080 Parallel mode:</i> Pin 18 is used as \overline{WR}_{8080} . Pin 19 is used as \overline{RD}_{8080} . Data is input or output on DB0-DB7.
21	DB1	H/L	I/O	
22	DB2	H/L	I/O	
23	DB3	H/L	I/O	
24	DB4	H/L	I/O	
25	DB5	H/L	I/O	
26	DB6	H/L	I/O	
27	DB7	H/L	I/O	
28	I_{REF}		O	Segment output current reference for brightness adjustment. A resistor should be connected between this pin and GND. Used to set the current.
29	V_{COMH}		O	High level voltage output for common signals. A low ESR capacitor should be connected between this pin and GND. Do not connect external power supply directly to this pin.



PIN	SIGNAL	LEVEL	DIRECTION	DESCRIPTION
30	V _{PANEL}	+12.5v to +13.5v	I	Driver supply voltage. Only high voltage input on chip. Power must be supplied externally. <i>Note: You must observe power sequencing for this pin.</i> <i>Power Up</i> – Display must be powered up and initialized before power is applied to the pin. <i>Power Down</i> – Power must be removed from this pin before the display is powered off.
31	NC			No connection.



PHOTO REFERENCE FOR PIN FUNCTIONS

*Note: FPC contacts are double sided. Make connection on either top or bottom.
 From front view, pin order is reverse of typical: left to right is 31 to 1.*

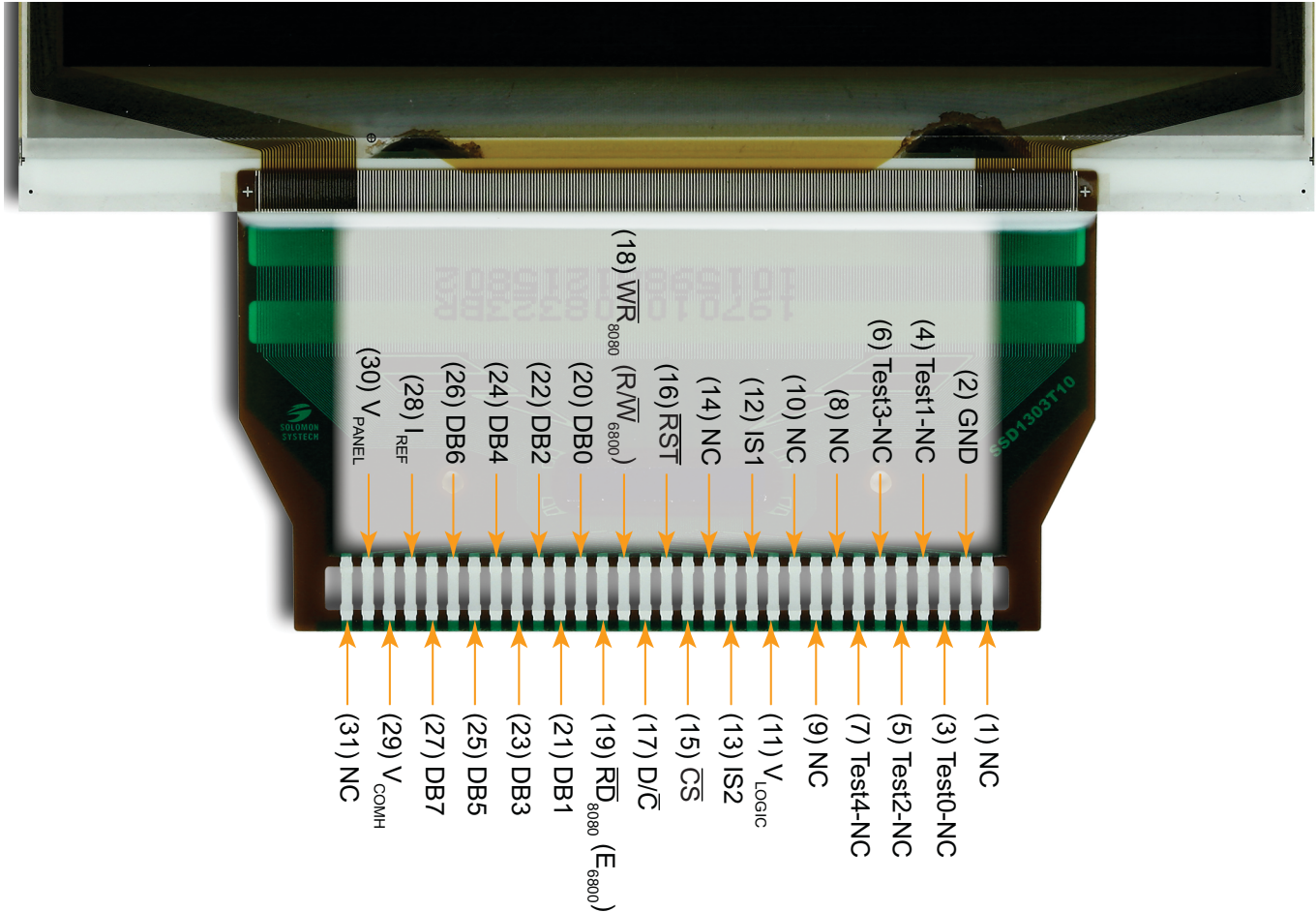

Figure 6. Front View of Unfolded FPC, Pins Labeled

ESD (ELECTRO-STATIC DISCHARGE)

The circuitry is industry standard CMOS logic and susceptible to ESD damage. Please use industry standard antistatic precautions as you would for any other PCB such as expansion cards or motherboards. Ground your body, work surfaces, and equipment.



OPTICAL SPECIFICATIONS

OPTICAL CHARACTERISTICS

ITEM	SYMBOL	TEST CONDITION	MINIMUM	TYPICAL	MAXIMUM
Viewing Angle				≥160°	
Dark Room Contrast Ratio ¹	CR	80 cd/m ²		≥2,000:1	
Luminous Intensity, Normal (IV)	L _{BRNORMAL}	With polarizer All pixels on Driving voltage: +13v Contrast setting: 0x8F Frame rate: 105 Hz	60 cd/m ²	80 cd/m ²	
Yellow Chromaticity	x	CIE (1931)	0.43	0.47	0.51
	y		0.45	0.49	0.53
Duty	1/64				
¹ Contrast Ratio = (brightness with pixels light)/(brightness with pixels dark). ² Response Time: The amount of time it takes a pixel to change from active to inactive or back again.					



Definition of Viewing Angle

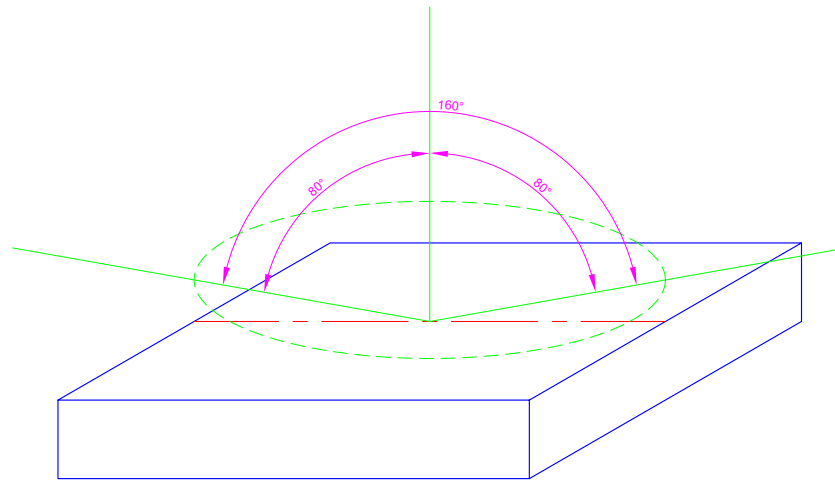

Figure 7. CFAL12864S-Y-B1 has a 160° Viewing Angle

OLED CONTROLLER INTERFACE

This module uses a Solomon Systech SSD1303 controller. For your reference, we added [APPENDIX D: SOLOMON SYSTECH 1303 CONTROLLER SPECIFICATION SHEET \(Pg. 38\)](#) to this Data Sheet.



MODULE RELIABILITY AND LONGEVITY

MODULE RELIABILITY

<i>Test Conditions: Ta = 25°C, RH = 50%, Frame Rate: 105 Hz, 50% checkerboard pattern</i>	
AVERAGE BRIGHTNESS	SPECIFICATION
100 cd/m ²	Brightness will be >50% of a new module's initial brightness for at least 20,000 hours of operation. Test Conditions: Contrast Setting: 0xC5 Duty: 1/64
80 cd/m ²	Brightness will be >50% of a new module's initial brightness for at least 25,000 hours of operation. Test Conditions: Contrast Setting: 0x8F Duty: 1/64
60 cd/m ²	Brightness will be >50% of a new module's initial brightness for at least 33,000 hours of operation. Test Conditions: Contrast Setting: 0x4C Duty: 1/4

OLED displays are an emissive technology. Each pixel is susceptible to dimming based on its individual use (burn-in). Frequently used pixels will dim more quickly than pixels that are not used as often. Please avoid using a bright, static, high-contrast image for a long time. If you want to leave the display powered on, please use scrolling text or alternating images to "wear level" the pixels. To conserve power and display lifetime, turn off or dim the display when it is not in use.

MODULE LONGEVITY (EOL/REPLACEMENT POLICY)

CrystalFontz is committed to making all of our modules available for as long as possible. For each module we introduce, we intend to offer it indefinitely. We do not preplan a module's obsolescence. The majority of modules we have introduced are still available.

We recognize that discontinuing a module may cause problems for some customers. However, rapidly changing technologies, component availability, or low customer order levels may force us to discontinue ("End of Life", EOL) a module. For example, we must occasionally discontinue a module when a supplier discontinues a component or a manufacturing process becomes obsolete. When we discontinue a module, we will do our best to find an acceptable replacement module with the same fit, form, and function.

In most situations, you will not notice a difference when comparing a "fit, form, and function" replacement module to the discontinued module. However, sometimes a change in component or process for the replacement module results in a slight variation, perhaps an improvement, over the previous design.

Although the replacement module is still within the stated Data Sheet specifications and tolerances of the discontinued module, changes may require modification to your circuit and/or firmware. Possible changes include:



- *Controller.* A new controller may require minor changes in your code.
- *Component tolerances.* Module components have manufacturing tolerances. In extreme cases, the tolerance stack can change the visual or operating characteristics.

Please understand that we avoid changing a module whenever possible; we only discontinue a module if we have no other option. We will post Part Change Notices on the product's webpage as soon as possible. If interested, you can subscribe to future part change notifications.

CARE AND HANDLING PRECAUTIONS

For optimum operation of the module and to prolong its life, please follow the precautions below. Excessive voltage will shorten the life of the module. You must drive the display within the specified voltage limit. See [Absolute Maximum Ratings \(Pg. 15\)](#).

ESD (ELECTRO-STATIC DISCHARGE)

The circuitry is industry standard CMOS logic and susceptible to ESD damage. Please use industry standard antistatic precautions as you would for any other PCB such as expansion cards or motherboards. Ground your body, work surfaces, and equipment.

DESIGN AND MOUNTING

- The exposed surface of the “glass” is actually a polarizer laminated on top of the glass. To protect the soft plastic polarizer from damage, the module ships with a protective film over the polarizer. Please peel off the protective film slowly. Peeling off the protective film abruptly may generate static electricity.
- The polarizer is made out of soft plastic and is easily scratched or damaged. When handling the module, avoid touching the polarizer. Finger oils are difficult to remove.
- To protect the soft plastic polarizer from damage, place a transparent plate (for example, acrylic, polycarbonate, or glass) in front of the module, leaving a small gap between the plate and the display surface. We use GE HP-92 Lexan, which is readily available and works well.
- Do not disassemble or modify the module.
- Do not modify the tab of the metal holder or make connections to it.
- Do not reverse polarity to the power supply connections. Reversing polarity will immediately ruin the module.



- Use care to keep the exposed terminals clean. Contamination, including fingerprints, may make soldering difficult and the reliability of the soldered connection poor.
- Sharp bends can damage the FPC. Do not crease FPC. Do not bend FPC tightly against the edge of the OLED panel.
- Do not repeatedly bend the FPC beyond its elastic region.

TAB SOLDERING

This module uses a "TAB" (tape automated bonding) or "COF" (chip on flex) style flex tail mated with a "COG" (chip on glass) display controller. The TAB is soldered directly to corresponding pads on your PCB by using a hot-bar soldering machine. High volume contract manufacturers will be familiar with this type of construction and its assembly methods.

Hot-bar soldering machines designed for prototype, rework, or repair of TAB connections are available from equipment suppliers at reasonable cost. The TAB style connection requires no separate connector so the cost is very low and the ultrathin profile of the display is maintained.

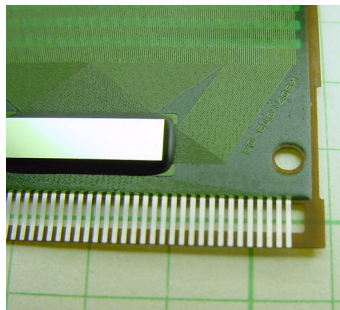

Figure 8. Typical Tab Solder Tail Construction

Hot Bar Soldering Machine

We have had good experience with the [APE](http://www.fancort.com/hotbar/hotbar.html) Bondmaster and their price is reasonable (\$US4K in June 2009). Other possible solutions are:

<http://www.fancort.com/hotbar/hotbar.html>

<https://www.manncorp.com/hot-bar-soldering/pbs-series/index.php?auto=done>

<http://www.cherusal.com/tm-111mkiii.htm>

The process is:

1. Pads on the PCB are tinned.
2. Tail is visually aligned to the PCB or by using the alignment holes.
3. Tail is held in place relative to the PCB with Kapton® tape.
4. Bondmaster head is lowered, applying pressure between the tail and the PCB.
5. Bondmaster is "cycled", which means it heats up to the point of melting the solder and then cools down.
6. Bondmaster head is raised.

Hand Soldering

For prototype work, hand soldering may be acceptable. Preset soldering iron to <260°C. Do not apply heat for more than 3 to 4 seconds. The FPC is quite fragile; use extreme care when soldering by hand. Great care must be taken since the conductors of the tail are completely exposed in the area where they are soldered. Solder only to the exposed terminals of the FPC connector. The use of Kapton® tape to help locate and secure the FPC may be useful.



AVOID SHOCK, IMPACT, TORQUE, OR TENSION

- Do not expose the module to strong mechanical shock, impact, torque, or tension.
- Do not drop, toss, bend, or twist the module.
- Do not place weight or pressure on the module.

CLEANING

- The polarizer (laminated to the glass) is soft plastic. The soft plastic is easily scratched or damaged. Be very careful when you clean the polarizer.
- Do not clean the polarizer with liquids. Do not wipe the polarizer with any type of cloth or swab (for example, Q-tips).
- Use the removable protective film to remove smudges (for example, fingerprints) and any foreign matter. If you no longer have the protective film, use standard transparent office tape (for example, Scotch® brand "Crystal Clear Tape"). If the polarizer is dusty, you may carefully blow it off with clean, dry, oil-free compressed air.

OPERATION

- We do not recommend connecting this module to a PC's parallel port as an "end product." This module is not "user friendly" and connecting it to a PC's parallel port is often difficult, frustrating, and can result in a "dead" display due to mishandling. For more information, see our forum thread at <http://www.crystalfontz.com/forum/showthread.php?s=&threadid=3257>.
- Your circuit should be designed to protect the module from ESD and power supply transients.
- Observe the operating temperature limitations: from -20°C minimum to +70°C maximum with minimal fluctuations. Operation outside of these limits may shorten the life and/or harm the display.
- Operate away from dust, moisture, and direct sunlight.

STORAGE AND RECYCLING



- Store in an ESD-approved container away from dust, moisture, and direct sunlight, fluorescent lamps, or any ultraviolet ray.
- Observe the storage temperature limitations: from -30°C minimum to +80°C maximum with minimal fluctuations. Rapid temperature changes can cause moisture to form, resulting in permanent damage.
- Do not allow weight to be placed on the modules while they are in storage.
- Please recycle your outdated CrystalFontz modules at an approved facility.



APPENDIX A: QUALITY ASSURANCE STANDARDS

INSPECTION CONDITIONS

- Environment
 - Temperature: $25\pm 5^{\circ}\text{C}$
 - Humidity: 30~85% RH (noncondensing)
- For visual inspection of active display area
 - Source lighting: two 20-Watt or one 40-Watt fluorescent light
 - Display adjusted for best contrast
 - Viewing distance: 30 ± 5 cm (about 12 inches)

Viewing angle: inspect at 45° angle of vertical line right and left, top and bottom

COLOR DEFINITIONS

We try to describe the appearance of our modules as accurately as possible. For the photos, we adjust for optimal appearance. Actual display appearance may vary due to (1) different operating conditions, (2) small variations of component tolerances, (3) inaccuracies of our camera, (4) color interpretation of the photos on your monitor, and/or (5) personal differences in the perception of color.

DEFINITION OF ACTIVE AREA AND VIEWING AREA

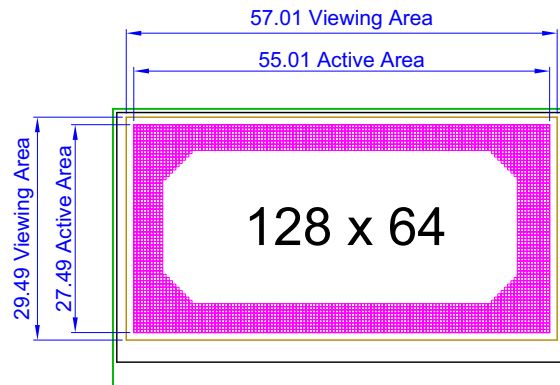



ACCEPTANCE SAMPLING

DEFECT TYPE	AQL*
Major	≤.65%
Minor	<1.0%
* Acceptable Quality Level: maximum allowable error rate or variation from standard	

DEFECTS CLASSIFICATION

Defects are defined as:

- Major Defect: results in failure or substantially reduces usability of unit for its intended purpose.
- Minor Defect: deviates from standards but is not likely to reduce usability for its intended purpose.

ACCEPTANCE STANDARDS

#	DEFECT TYPE	CRITERIA			MAJOR / MINOR	
1	Electrical defects	1. No display, display malfunctions, or shorted segments. 2. Current consumption exceeds specifications.			Major	
2	Viewing area defect	Viewing area does not meet specifications.			Major	
3	Blemishes or foreign matter on display segments		<i>Defect Size</i>	<i>Acceptable Qty</i>	Minor	
			≤0.30 mm	3		
			≤2 defects within 10 mm of each other			
4	Dark lines or scratches in display area		<i>Defect Width</i>	<i>Defect Length</i>	<i>Acceptable Qty</i>	Minor
			≤0.03 mm	≤3.0 mm	3	
			0.03 to 0.05	≤2.0 mm	2	
			0.05 to 0.08	≤2.0 mm	1	
			0.08 to 0.10	≤3.0 mm	0	
			≥0.10	>3.0 mm	0	



ACCEPTANCE STANDARDS

#	DEFECT TYPE	CRITERIA		MAJOR / MINOR
5	Bubbles between polarizer film and glass	<i>Defect Size</i>	<i>Acceptable Qty</i>	Minor
		≤0.20 mm	Ignore	
		0.20 to 0.40 mm	3	
		0.40 to 0.60 mm	2	
		≥0.60 mm	0	
6	Display pattern defect			Minor
		<i>Pixel Size</i>	<i>Acceptable Qty</i>	
		$((A+B)/2) \leq 0.20 \text{ mm}$	≤3 total defects ≤2 pinholes per digit	
		C > 0 mm		
		$((D+E)/2) \leq 0.25 \text{ mm}$		
		$((F+G)/2) \leq 0.25 \text{ mm}$		
7	PCB defects	1. Oxidation or contamination on connectors.* 2. Wrong parts, missing parts, or parts not in specification.* 3. Jumpers set incorrectly. 4. Solder (if any) on bezel, LED pad, zebra pad, or screw hole pad is not smooth. *Minor if display functions correctly. Major if the display fails.		Minor
8	Soldering defects	1. Unmelted solder paste. 2. Cold solder joints, missing solder connections, or oxidation.* 3. Solder bridges causing short circuits.* 4. Residue or solder balls. 5. Solder flux is black or brown. *Minor if display functions correctly. Major if the display fails.		Minor



APPENDIX B: SAMPLE CODE

SOURCES FOR DRIVER LIBRARIES

Graphic driver libraries may save a lot of time and help you develop a more professional product. Possible library sources are [easyGUI](#), [en.radzio.dxp.pl](#), [Gwentech](#), [Micrijm](#), [RAMTEX](#), and [Segger emWin](#).

SAMPLE CODE

This code will initialize the display and then cycle through three images. You can download the complete source from this link: http://www.crystalfontz.com/products/document/2047/Demonstration_Code.zip.

Note: Please observe V_{PANEL} sequencing as described in [Details of Interface Pin Function \(Pg. 17\)](#). See also [Power Up and Power Down Sequencing \(Pg. 14\)](#).

```
#include <avr/io.h>
#include <util/delay.h>

#define LCD_DC (1 << 7)
#define LCD_RW (1 << 6)
#define LCD_E (1 << 5)
#define LCD_CS (1 << 1)
#define LCD_RES (1 << 2)

uint8_t logo_screen[8][128] =
{
// see full code from website
};

uint8_t bitmap3[8][128] =
{
// see full code from website
};

uint8_t bitmap4[8][128] =
{
// see full code from website
};

void delay(uint32_t twait)
{
    while (twait--)
        asm volatile ("nop");
}

void lcd_cmd(uint8_t cmd)
{
    PORTA = cmd;// set up data on bus

    PORTC &= ~(LCD_DC | LCD_RW | LCD_CS);// command mode, write mode, chip select

    // clock E
    PORTC |= LCD_E;
    PORTC &= ~LCD_E;

    PORTC |= LCD_CS;// remove chip select
}
```



```
void lcd_dat(uint8_t dat)
{
    PORTA = dat; // set up data on bus

    PORTC |= LCD_DC; // data mode
    PORTC &= ~(LCD_RW | LCD_CS); // write mode, chip select

    // clock E
    PORTC |= LCD_E;
    PORTC &= ~LCD_E;

    PORTC |= LCD_CS; // remove chip select
}

void lcd_clr(uint8_t color)
{
    int i,p;

    lcd_cmd(0x40);

    for (p=0;p<8;p++) // pages
    {
        lcd_cmd(0xb0 + p);
        lcd_cmd(0x10);
        lcd_cmd(0x00);
        for (i=0;i<132;i++) // ?????
        {
            lcd_dat(color);
        }
    }
}

typedef uint8_t bitmap_t[8][128];

void bmp(bitmap_t b)
{
    int i,j;

    lcd_cmd(0x00);
    lcd_cmd(0x10);

    lcd_cmd(0xB0);

    for (j=0;j<8;j++)
    {
        lcd_dat(0);
        lcd_dat(0);
        for (i=0;i<128;i++)
            lcd_dat( b[j][i] );
        lcd_dat(0);
        lcd_dat(0);
    }
}

/*****/
int main( void )
{
    PORTD = 0; // all off

    DDRD |= (1<<3); // VPP output
    DDRA = 0xFF;

    // MODE6800
    PORTC = 0b11011110;
```



```
DDRC = 0xFE;

DDRD |= 0x06; // led pins output

delay(20000L);

PORTC &= ~LCD_RES;
delay(10000);
PORTC |= LCD_RES;

delay(20000);

// enable VPP
PORTD |= (1<<3);

delay(200000L);

lcd_cmd(0xa8); //Set Mux
lcd_cmd(0x3f); //64mux

lcd_cmd(0x20); //Set Memory Addressing Mode
lcd_cmd(0x00); //Horizontal

lcd_cmd(0x81); //set contrast control
lcd_cmd(0xA0); //second byte

lcd_cmd(0x82); //set brightness control
lcd_cmd(0x80); //second byte

lcd_cmd(0xaf); //Set Display ON

delay(5000L);

lcd_clr(0);

delay(20000L);

while (1)
{
    bmp(logo_screen);
    delay(500000L);
    bmp(bitmap3);
    delay(500000L);
    bmp(bitmap4);
    delay(500000L);
}

while (1)
{
    // nothing
    PORTD |= (1<<1);
    delay(40000);
    PORTD &= ~(1<<1);
    delay(40000);
}
return 0;
}
```



APPENDIX C: OLED MODULE TERMS AND SYMBOLS

CrystalFontz Symbol	Equivalent	Equivalent	Equivalent	Description
C				Capacitor
cd/m ²	nit			Candela meter squared is the standard unit of measurement for luminous intensity (photometric brightness).
CIE				A color model based on human perception developed by the CIE (Commission Internationale de l'Eclairage) committee.
CLS				Clock select pin.
COF	COT	TAB		Chip On Flex. Controller is on the FPC. Similar in appearance to "TAB". The flex circuit on COF is typically much thinner than the flex of a "flex tail".
COG				Chip On Glass. Controller is on the glass panel.
COM				Common driver. Common signal output for OLED display.
CR				Contrast Ratio = (brightness with pixels light)/ (brightness with pixels dark).
\overline{CS}	CS#			Chip select input. <i>Low:</i> Controller chip is selected. Communications with host is possible. <i>High:</i> Controller chip is not selected. Host interface signals are ignored by the controller.
D				Diode
DB0 ~ DBn	D0 ~ Dn			Bidirectional databus connects to 8-bit or 16-bit standard host databus. When SPI (serial interface) is selected, DB0 serves as the serial clock input signal (SCL or SCLK) and DB1 serves as the serial data input signal (SI or SDIN). DB2 to DBn are set to high impedance.
D/\overline{C}	RS	A0	CD or D/C#	Data/Command control. Determines whether data bits are data or command. <i>1 – High:</i> Addresses the data register. <i>0 – Low:</i> Addresses the command register.



Crystalfontz Symbol	Equivalent	Equivalent	Equivalent	Description															
ESD				Electro-Static Discharge. Sudden and brief electrical current that flows between two objects. ESD between a human and an OLED can cause permanent damage.															
FB				Feedback input for the booster circuit. Use to adjust booster output voltage level, V_{PANEL} .															
FFC				Flat Flex Cable. Used for Touch Screen connection. Also called "pigtail".															
FG				Frame Ground.															
FPC				Flexible Printed Circuit. Also called "flex tail". Typically much thicker than the "flex" film of COF (Chip On Flex).															
GDR				Gate Drive. Output signal drives the gate of the external NMOS of the booster circuit.															
GND	V_{SS}			Ground. Must be connected to an external ground.															
I_{LOGIC}	I_{DD}			Operating current for V_{LOGIC} .															
$I_{LOGIC, SLEEP}$	$I_{DD, SLEEP}$			Sleep mode current for V_{LOGIC} .															
I_{PANEL}	I_{CC}			Supply current for V_{PANEL} .															
$I_{PANEL, SLEEP}$	$I_{CC, SLEEP}$			Sleep mode current for V_{PANEL} .															
I_{REF}				Segment output current reference for brightness adjustment. A resistor should be connected between this pin and GND. Used to set the current.															
I/O				Input/Output.															
IS1	BS1	C86	M80	<table border="1"> <thead> <tr> <th>IS1</th> <th>IS2</th> <th>Interface Mode</th> </tr> </thead> <tbody> <tr> <td>0</td> <td>0</td> <td>SPI (Serial)</td> </tr> <tr> <td>0</td> <td>1</td> <td>6800 Parallel</td> </tr> <tr> <td>1</td> <td>0</td> <td>Not Allowed</td> </tr> <tr> <td>1</td> <td>1</td> <td>8080 Parallel</td> </tr> </tbody> </table>	IS1	IS2	Interface Mode	0	0	SPI (Serial)	0	1	6800 Parallel	1	0	Not Allowed	1	1	8080 Parallel
IS1	IS2	Interface Mode																	
0	0	SPI (Serial)																	
0	1	6800 Parallel																	
1	0	Not Allowed																	
1	1	8080 Parallel																	
IS2	BS2	P/S	\overline{MS} , MS, \overline{MS} or M/S#																
$L_{BRNORMAL}$	IV			Luminous Intensity Brightness, NORMAL operation.															
$L_{BRSTANDBY}$	IV			Luminous Intensity Brightness, STANDBY.															



Crystalfontz Symbol	Equivalent	Equivalent	Equivalent	Description
mm				Millimeter or millimetre. Unit of length equal to one thousandth of a meter. 1 millimeter = 0.0394 inches.
mW				Milliwatt is equal to one thousandth of a Watt. Watts = Volts x Amps.
NC	nc			No Connection.
OLED				Organic light-emitting diode
P _{OPERATION}	P _T			Normal mode Power consumption
P _{STANDBY}				Standby mode Power consumption.
Q				Transistor, including FET and MOSFET.
R				Resistor
\overline{RD}_{8080} (E ₆₈₀₀)	\overline{RD} (E)	E (\overline{RD})	E	Host interface input. 8080 Host: Active low. Signal on the databus is latched at the rising edge of \overline{RD} . 6800 Host: Enable control signal input active high. E = High: Read or Write operation is active E = Low: No operation
RH	Rh			Relative Humidity.
RoHS				Restriction of Hazardous Substances Directive, an environmental standard.
\overline{RST}	\overline{RES}	RST#	RES#	Reset signal. Low: Display controller is reset. The \overline{RST} pin should be pulsed low shortly after power is applied. High: The \overline{RST} pin should be brought high for normal operation.
SCL	SCK			Serial Clock signal.
SEG				Segment driver. Segment signal output for OLED display.
SENSE				Source current for external NMOS of booster circuit.
SI	SDA	MOSI		Serial data Input signal.
SW				Switch output drives the gate of the external NMOS of the booster circuit.



Crystalfontz Symbol	Equivalent	Equivalent	Equivalent	Description
T _a	TA			“Ambient temperature” is the temperature of the air that surrounds a component.
T _{OP}				OPerating temperature.
T _{ST}	T _{STG}			Storage Temperature.
V _{BREF}				Internal voltage reference for booster circuit. A decoupling capacitor, typically 1μF, should be connected to GND.
V _{COMH}				High level voltage output for common signals. A low ESR capacitor should be connected between this pin and GND. Do not connect external power supply directly to this pin.
V _{IH}	V _{ICH}			High level input voltage.
V _{IL}	V _{LCH}			Low level input voltage.
V _{LOGIC}	V _{DD}	V _{DD1}	V _{CC}	Power supply input. Must be connected to an external source.
V _{LOGIC I/O}	V _{DD I/O}	V _{I/O}	V _{CC I/O}	Supply voltage for I/O signals.
V _{OH}	V _{OHC}			High level output voltage.
V _{OL}	V _{OLC}			Low level output voltage.
V _{PANEL}	V _{PP}	V _{CC}		<p>Driver supply voltage. Only high voltage input on chip. Power must be supplied externally. <i>Note: You must observe power sequencing for this signal.</i></p> <p><i>Power Up</i> – Display must be powered up and initialized before power is applied to the signal.</p> <p><i>Power Down</i> – Power must be removed from this signal before the display is powered off.</p>



CrystalFontz Symbol	Equivalent	Equivalent	Equivalent	Description
V_{REF}				Voltage reference pin for pre-charge voltage in driving OLED device. Voltage should be set to match with the OLED driving voltage in current drive phase. It can either be supplied externally or by connecting to V_{PANEL} .
V_{SL}				Segment voltage reference pin. This pin should be left open.
\overline{WR}_{8080} (R/\overline{W}_{6800})	R/\overline{W} (\overline{WR})	\overline{WR} (R/\overline{W})	$R/\overline{W}\#$	Host interface input. <i>8080 Host:</i> Active low. Signal <u>on</u> the databus is latched at the rising edge of \overline{WR} signal. <i>6800 Host:</i> Read/Write control signal output. R/\overline{W} = High: Read (Host←Module) R/\overline{W} = Low: Write (Host→Module)



APPENDIX D: SOLOMON SYSTECH 1303 CONTROLLER SPECIFICATION SHEET

The complete SOLOMON SYSTECH 1303 specifications file *Advance Information 132 x 64 Dot Matrix OLED/PLED Segment/Common Driver with Controller* revision 1.7 (56 pages) follows.

SSD1303

Advance Information

**132 x 64 Dot Matrix
OLED/PLED Segment/Common Driver with Controller**

This document contains information on a new product. Specifications and information herein are subject to change without notice.

<http://www.solomon-systech.com>

SSD1303 | Rev 1.7 | P 1/56 | May 2005 | Copyright © 2005 **Solomon Systech Limited**



TABLE OF CONTENTS

1	GENERAL INFORMATION	5
2	FEATURES	5
3	ORDERING INFORMATION	6
4	BLOCK DIAGRAM	7
5	DIE PAD FLOOR PLAN	8
6	PIN DESCRIPTION	12
7	FUNCTIONAL BLOCK DESCRIPTIONS	15
7.1	OSCILLATOR CIRCUIT AND DISPLAY TIME GENERATOR	15
7.2	RESET CIRCUIT	15
7.3	COMMAND DECODER AND COMMAND INTERFACE	15
7.4	MPU PARALLEL 6800-SERIES INTERFACE	16
7.5	MPU PARALLEL 8080-SERIES INTERFACE	16
7.6	MPU SERIAL INTERFACE	17
7.7	GRAPHIC DISPLAY DATA RAM (GDDRAM)	17
7.8	CURRENT CONTROL AND VOLTAGE CONTROL.....	17
7.9	SEGMENT DRIVERS / COMMON DRIVERS	18
7.10	AREA COLOUR DECODER.....	18
7.11	DC-DC VOLTAGE CONVERTER	19
8	COMMAND TABLE	21
8.1	DATA READ / WRITE.....	24
9	COMMAND DESCRIPTIONS	25
10	MAXIMUM RATINGS	32
11	DC CHARACTERISTICS	33
12	AC CHARACTERISTICS	34
13	APPLICATION EXAMPLE	38
14	SSD1303T3R1 PACKAGE DETAILS	39
	SSD1303T3R1 PIN ASSIGNMENT	39
15	SSD1303T6R1 PACKAGE DETAILS	43
	SSD1303T6R1 PIN ASSIGNMENT	43
	SSD1303T6R1 TAB PACKAGE DIMENSIONS	45
16	SSD1303T8R1 PACKAGE DETAILS	47
	SSD1303T8R1 PIN ASSIGNMENT	47
	SSD1303T8R1 TAB PACKAGE DIMENSIONS	49
17	SSD1303T9R1 PACKAGE DETAILS	51
	SSD1303T9R1 PIN ASSIGNMENT	51
	SSD1303T9R1 TAB PACKAGE DIMENSIONS	53

TABLE OF FIGURES

Figure 1 - Block Diagram.....	7
Figure 2 - SSD1303Z Pin Assignment	8
Figure 3 - SSD1303Z Alignment mark dimensions	11
Figure 4 - Oscillator Circuit.....	15
Figure 5 - Display data read back procedure - insertion of dummy read.....	16
Figure 6 – Display data write procedure in SPI mode.....	17
Figure 7 - DC-DC voltage converter circuit	19
Figure 8 - Horizontal scroll direction.....	25
Figure 9 - Segment current vs Contrast setting	26
Figure 10 - 6800-series MPU parallel interface characteristics	35
Figure 11 - 8080-series MPU parallel interface characteristics	36
Figure 12 - Serial interface characteristics.....	37
Figure 13 - Application Example (Block Diagram of SSD1303T3).....	38
Figure 14 - SSD1303T3R1 pin assignment (Copper view, Normal TAB design)	39
Figure 15 - SSD1303T6R1 pin assignment (Copper view).....	43
Figure 16 - SSD1303T9R1 pin assignment (Copper view).....	51

LIST OF TABLES

Table 1 - Ordering Information	6
Table 2 - SSD1303Z Die Pad Coordinates	9
Table 3 - Passive component selection:	20
Table 4 - Command table.....	21
Table 5 - Read command table.....	23
Table 6 - Address increment table (Automatic).....	24
Table 7 - Maximum Ratings	32
Table 8 - DC Characteristics	33
Table 9 - AC Characteristics	34
Table 10 - 6800-Series MPU Parallel Interface Timing Characteristics.....	35
Table 11 - 8080-Series MPU Parallel Interface Timing Characteristics.....	36
Table 12 - Serial Interface Timing Characteristics	37
Table 13 - SSD1303T3R1 pin assignment.....	40
Table 14 - SSD1303T6R1 pin assignment.....	44
Table 15 - SSD1303T8R1 pin assignment.....	48
Table 16 - SSD1303T9R1 pin assignment.....	52

1 GENERAL INFORMATION

The SSD1303 is a single-chip CMOS OLED/PLED driver with controller for organic/polymer light emitting diode dot-matrix graphic display system. It consists of 132 segments, 64 commons that can support a maximum display resolution of 132x64. Besides, there are 4-colour selections to support monochrome or area colour OLED/PLED. This IC is designed for Common Cathode type OLED panel.

The SSD1303 embeds with contrast control, display RAM and oscillator, which reduces the number of external components and power consumption. It is suitable for many compact portable applications, such as mobile phone sub-display, calculator and MP3 player, etc.

2 FEATURES

- Support maximum 132 x 64 dot matrix panel
- Area colour support with 4 Colour Selection and 64 steps per colour
- Logic voltage supply: $V_{DD} = 2.4V - 3.5V$
- High voltage supply: $V_{CC} = 7.0V - 16.0V$
- Maximum segment output current: 320uA
- Maximum common sink current: 45mA
- Embedded 132 x 64 bit SRAM display buffer
- 256-step Contrast Control on monochrome passive OLED panel
- On-Chip Oscillator
- Programmable Frame Frequency and Multiplexing Ratio
- 8-bit 6800-series Parallel Interface, 8-bit 8080-series Parallel Interface, Serial Peripheral Interface
- Row Re-mapping and Column Re-mapping
- Vertical Scrolling
- Automatic horizontal scrolling function
- Low power consumption
- Wide range of operating temperatures: -40 to 90 °C

3 ORDERING INFORMATION

Table 1 - Ordering Information

Ordering Part Number	SEG	COM	Package Form	Reference	Remark
SSD1303Z	132	64	Gold Bump Die	Page 8	Die size: 9.22mm x 1.55mm Pad pitch: COM 51.8µm SEG 52.2µm
SSD1303T3R1	96	64	TAB	Page 39	<ul style="list-style-type: none"> • 35mm film • 4 sprocket hole • Folding TAB • 80 / 68 / SPI interface • Output lead pitch 0.12974mm
SSD1303T6R1	132	64	TAB	Page 43	<ul style="list-style-type: none"> • 35mm film • 4 sprocket hole • Folding TAB • 80 / 68 / SPI interface • Output lead pitch 0.11976
SSD1303T8R1	96	64	TAB	Page 47	<ul style="list-style-type: none"> • 35mm film • 4 sprocket hole • Folding TAB • 80 / 68 / SPI interface • Output lead pitch 0.12974mm
SSD1303T9R1	96	64	TAB	Page 51	<ul style="list-style-type: none"> • 35mm film • 4 sprocket hole • Folding TAB • 80 / 68 / SPI interface • Output lead pitch 0.12974mm

4 BLOCK DIAGRAM

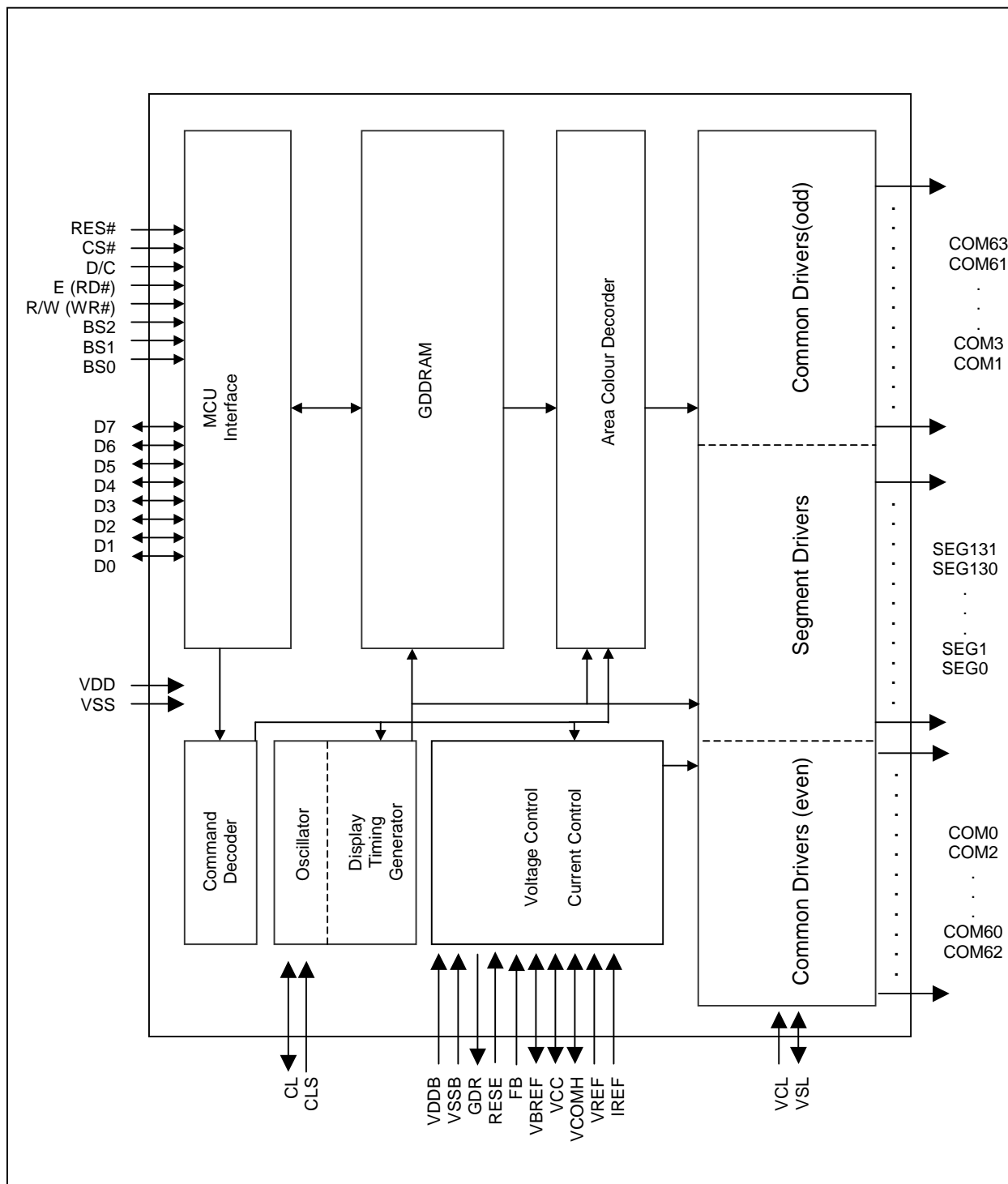
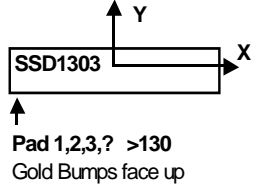
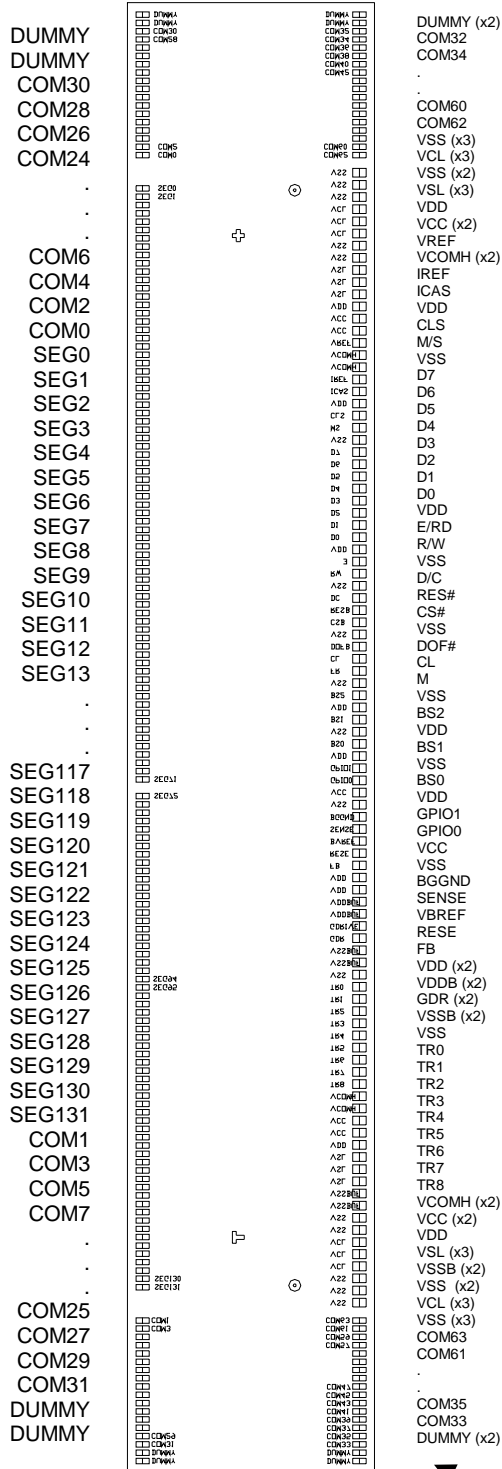

Figure 1 - Block Diagram

5 DIE PAD FLOOR PLAN

Figure 2 - SSD1303Z Pin Assignment



Die size	9.22mm x 1.55mm
Die height	475 +/- 25um

Bump height	Nominal 18um
Bump size	
Pad 1-18, 113-298	34um x 84um
Pad 19-112	54um x 84um

Alignment mark		
T shape	(-3132.9, 79.5)	75um x 75um
+ shape	(3148.9, 79.5)	75um x 75um
Circle	(3433.9, -274.6)	R37.5um inner 18um
Circle	(-3433.9, -274.6)	R37.5um inner 18um

PAD 1

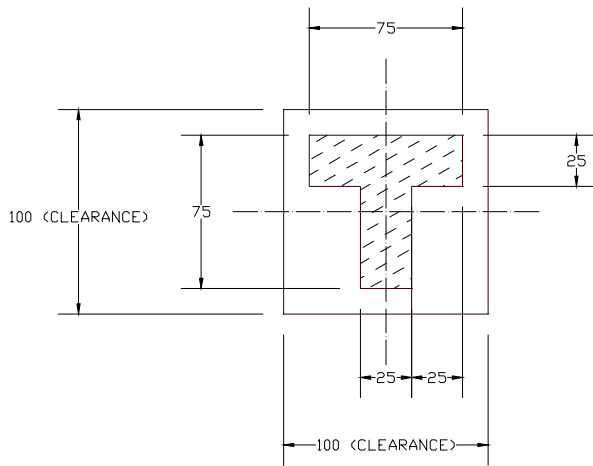

Table 2 - SSD1303Z Die Pad Coordinates

Pad no.	Pad Name	X-pos	Y-pos	Pad no.	Pad Name	X-pos	Y-pos	Pad no.	Pad Name	X-pos	Y-pos
1	NC	-4535.4	-679.6	61	VCC	-342.9	-679.6	121	COM46	4068.4	-679.6
2	NC	-4483.2	-679.6	62	GPIO0	-267.2	-679.6	122	COM44	4120.2	-679.6
3	COM33	-4431.0	-679.6	63	GPIO1	-190.5	-679.6	123	COM42	4172.0	-679.6
4	COM35	-4379.2	-679.6	64	VDD	-114.3	-679.6	124	COM40	4223.8	-679.6
5	COM37	-4327.4	-679.6	65	BS0	-38.1	-679.6	125	COM38	4275.6	-679.6
6	COM39	-4275.6	-679.6	66	VSS	38.1	-679.6	126	COM36	4327.4	-679.6
7	COM41	-4223.8	-679.6	67	BS1	114.3	-679.6	127	COM34	4379.2	-679.6
8	COM43	-4172.0	-679.6	68	VDD	190.5	-679.6	128	COM32	4431.0	-679.6
9	COM45	-4120.2	-679.6	69	BS2	266.7	-679.6	129	NC	4483.2	-679.6
10	COM47	-4068.4	-679.6	70	VSS	342.9	-679.6	130	NC	4535.4	-679.6
11	COM49	-4016.6	-679.6	71	M	419.1	-679.6	131	NC	4535.4	679.6
12	COM51	-3964.8	-679.6	72	CL	495.3	-679.6	132	NC	4483.2	679.6
13	COM53	-3913.0	-679.6	73	DOF#	571.5	-679.6	133	COM30	4431.0	679.6
14	COM55	-3861.2	-679.6	74	VSS	647.7	-679.6	134	COM28	4379.2	679.6
15	COM57	-3809.4	-679.6	75	CS#	723.9	-679.6	135	COM26	4327.4	679.6
16	COM59	-3757.6	-679.6	76	RES#	800.1	-679.6	136	COM24	4275.6	679.6
17	COM61	-3705.8	-679.6	77	D/C	876.3	-679.6	137	COM22	4223.8	679.6
18	COM63	-3654.0	-679.6	78	VSS	952.5	-679.6	138	COM20	4172.0	679.6
19	VSS	-3543.3	-679.6	79	R/W	1028.7	-679.6	139	COM18	4120.2	679.6
20	VSS	-3467.1	-679.6	80	E/RD	1104.9	-679.6	140	COM16	4068.4	679.6
21	VSS	-3390.9	-679.6	81	VDD	1181.1	-679.6	141	COM14	4016.6	679.6
22	VCL	-3314.7	-679.6	82	D0	1257.3	-679.6	142	COM12	3964.8	679.6
23	VCL	-3238.5	-679.6	83	D1	1333.5	-679.6	143	COM10	3913.0	679.6
24	VCL	-3162.3	-679.6	84	D2	1409.7	-679.6	144	COM8	3861.2	679.6
25	VSS	-3086.1	-679.6	85	D3	1485.9	-679.6	145	COM6	3809.4	679.6
26	VSS	-3009.9	-679.6	86	D4	1562.1	-679.6	146	COM4	3757.6	679.6
27	VSSB	-2933.7	-679.6	87	D5	1638.3	-679.6	147	COM2	3705.8	679.6
28	VSSB	-2857.5	-679.6	88	D6	1714.5	-679.6	148	COM0	3654.0	679.6
29	VSL	-2781.3	-679.6	89	D7	1790.7	-679.6	149	SEG0	3445.2	679.6
30	VSL	-2705.1	-679.6	90	VSS	1866.9	-679.6	150	SEG1	3393.0	679.6
31	VSL	-2628.9	-679.6	91	M/S	1943.1	-679.6	151	SEG2	3340.8	679.6
32	VDD	-2552.7	-679.6	92	CLS	2019.3	-679.6	152	SEG3	3288.6	679.6
33	VCC	-2476.5	-679.6	93	VDD	2095.5	-679.6	153	SEG4	3236.4	679.6
34	VCC	-2400.3	-679.6	94	ICAS	2171.7	-679.6	154	SEG5	3184.2	679.6
35	VCOMH	-2324.1	-679.6	95	IREF	2247.9	-679.6	155	SEG6	3132.0	679.6
36	VCOMH	-2247.9	-679.6	96	VCOMH	2324.1	-679.6	156	SEG7	3079.8	679.6
37	TR8	-2171.7	-679.6	97	VCOMH	2400.3	-679.6	157	SEG8	3027.6	679.6
38	TR7	-2095.5	-679.6	98	VREF	2476.5	-679.6	158	SEG9	2975.4	679.6
39	TR6	-2019.3	-679.6	99	VCC	2552.7	-679.6	159	SEG10	2923.2	679.6
40	TR5	-1943.1	-679.6	100	VCC	2628.9	-679.6	160	SEG11	2871.0	679.6
41	TR4	-1866.9	-679.6	101	VDD	2705.1	-679.6	161	SEG12	2818.8	679.6
42	TR3	-1790.7	-679.6	102	VSL	2781.3	-679.6	162	SEG13	2766.6	679.6
43	TR2	-1714.5	-679.6	103	VSL	2857.5	-679.6	163	SEG14	2714.4	679.6
44	TR1	-1638.3	-679.6	104	VSL	2933.7	-679.6	164	SEG15	2662.2	679.6
45	TR0	-1562.1	-679.6	105	VSS	3009.9	-679.6	165	SEG16	2610.0	679.6
46	VSS	-1485.9	-679.6	106	VSS	3086.1	-679.6	166	SEG17	2557.8	679.6
47	VSSB	-1409.7	-679.6	107	VCL	3162.3	-679.6	167	SEG18	2505.6	679.6
48	VSSB	-1333.5	-679.6	108	VCL	3238.5	-679.6	168	SEG19	2453.4	679.6
49	GDR	-1257.3	-679.6	109	VCL	3314.7	-679.6	169	SEG20	2401.2	679.6
50	GDR	-1181.1	-679.6	110	VSS	3390.9	-679.6	170	SEG21	2349.0	679.6
51	VDDB	-1104.9	-679.6	111	VSS	3467.1	-679.6	171	SEG22	2296.8	679.6
52	VDDB	-1028.7	-679.6	112	VSS	3543.3	-679.6	172	SEG23	2244.6	679.6
53	VDD	-952.5	-679.6	113	COM62	3654.0	-679.6	173	SEG24	2192.4	679.6
54	VDD	-876.3	-679.6	114	COM60	3705.8	-679.6	174	SEG25	2140.2	679.6
55	FB	-800.1	-679.6	115	COM58	3757.6	-679.6	175	SEG26	2088.0	679.6
56	RESE	-723.9	-679.6	116	COM56	3809.4	-679.6	176	SEG27	2035.8	679.6
57	VBREF	-647.7	-679.6	117	COM54	3861.2	-679.6	177	SEG28	1983.6	679.6
58	SENSE	-571.5	-679.6	118	COM52	3913.0	-679.6	178	SEG29	1931.4	679.6
59	BGGND	-495.3	-679.6	119	COM50	3964.8	-679.6	179	SEG30	1879.2	679.6
60	VSS	-419.1	-679.6	120	COM48	4016.6	-679.6	180	SEG31	1827.0	679.6

Pad no.	Pad Name	X-pos	Y-pos	Pad no.	Pad Name	X-pos	Y-pos
181	SEG32	1774.8	679.6	241	SEG92	-1409.4	679.6
182	SEG33	1722.6	679.6	242	SEG93	-1461.6	679.6
183	SEG34	1670.4	679.6	243	SEG94	-1513.8	679.6
184	SEG35	1618.2	679.6	244	SEG95	-1566.0	679.6
185	SEG36	1566.0	679.6	245	SEG96	-1618.2	679.6
186	SEG37	1513.8	679.6	246	SEG97	-1670.4	679.6
187	SEG38	1461.6	679.6	247	SEG98	-1722.6	679.6
188	SEG39	1409.4	679.6	248	SEG99	-1774.8	679.6
189	SEG40	1357.2	679.6	249	SEG100	-1827.0	679.6
190	SEG41	1305.0	679.6	250	SEG101	-1879.2	679.6
191	SEG42	1252.8	679.6	251	SEG102	-1931.4	679.6
192	SEG43	1200.6	679.6	252	SEG103	-1983.6	679.6
193	SEG44	1148.4	679.6	253	SEG104	-2035.8	679.6
194	SEG45	1096.2	679.6	254	SEG105	-2088.0	679.6
195	SEG46	1044.0	679.6	255	SEG106	-2140.2	679.6
196	SEG47	991.8	679.6	256	SEG107	-2192.4	679.6
197	SEG48	939.6	679.6	257	SEG108	-2244.6	679.6
198	SEG49	887.4	679.6	258	SEG109	-2296.8	679.6
199	SEG50	835.2	679.6	259	SEG110	-2349.0	679.6
200	SEG51	783.0	679.6	260	SEG111	-2401.2	679.6
201	SEG52	730.8	679.6	261	SEG112	-2453.4	679.6
202	SEG53	678.6	679.6	262	SEG113	-2505.6	679.6
203	SEG54	626.4	679.6	263	SEG114	-2557.8	679.6
204	SEG55	574.2	679.6	264	SEG115	-2610.0	679.6
205	SEG56	522.0	679.6	265	SEG116	-2662.2	679.6
206	SEG57	469.8	679.6	266	SEG117	-2714.4	679.6
207	SEG58	417.6	679.6	267	SEG118	-2766.6	679.6
208	SEG59	365.4	679.6	268	SEG119	-2818.8	679.6
209	SEG60	313.2	679.6	269	SEG120	-2871.0	679.6
210	SEG61	261.0	679.6	270	SEG121	-2923.2	679.6
211	SEG62	208.8	679.6	271	SEG122	-2975.4	679.6
212	SEG63	156.6	679.6	272	SEG123	-3027.6	679.6
213	SEG64	104.4	679.6	273	SEG124	-3079.8	679.6
214	SEG65	52.2	679.6	274	SEG125	-3132.0	679.6
215	SEG66	0.0	679.6	275	SEG126	-3184.2	679.6
216	SEG67	-52.2	679.6	276	SEG127	-3236.4	679.6
217	SEG68	-104.4	679.6	277	SEG128	-3288.6	679.6
218	SEG69	-156.6	679.6	278	SEG129	-3340.8	679.6
219	SEG70	-208.8	679.6	279	SEG130	-3393.0	679.6
220	SEG71	-261.0	679.6	280	SEG131	-3445.2	679.6
221	SEG72	-365.4	679.6	281	COM1	-3654.0	679.6
222	SEG73	-417.6	679.6	282	COM3	-3705.8	679.6
223	SEG74	-469.8	679.6	283	COM5	-3757.6	679.6
224	SEG75	-522.0	679.6	284	COM7	-3809.4	679.6
225	SEG76	-574.2	679.6	285	COM9	-3861.2	679.6
226	SEG77	-626.4	679.6	286	COM11	-3913.0	679.6
227	SEG78	-678.6	679.6	287	COM13	-3964.8	679.6
228	SEG79	-730.8	679.6	288	COM15	-4016.6	679.6
229	SEG80	-783.0	679.6	289	COM17	-4068.4	679.6
230	SEG81	-835.2	679.6	290	COM19	-4120.2	679.6
231	SEG82	-887.4	679.6	291	COM21	-4172.0	679.6
232	SEG83	-939.6	679.6	292	COM23	-4223.8	679.6
233	SEG84	-991.8	679.6	293	COM25	-4275.6	679.6
234	SEG85	-1044.0	679.6	294	COM27	-4327.4	679.6
235	SEG86	-1096.2	679.6	295	COM29	-4379.2	679.6
236	SEG87	-1148.4	679.6	296	COM31	-4431.0	679.6
237	SEG88	-1200.6	679.6	297	NC	-4483.2	679.6
238	SEG89	-1252.8	679.6	298	NC	-4535.4	679.6
239	SEG90	-1305.0	679.6				
240	SEG91	-1357.2	679.6				

Figure 3 - SSD1303Z Alignment mark dimensions



T shape

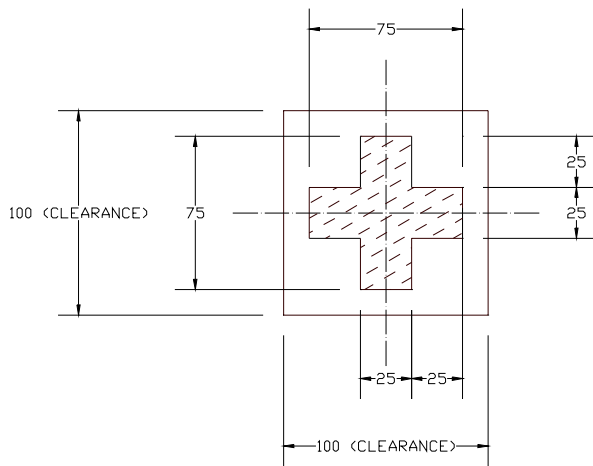

+ shape

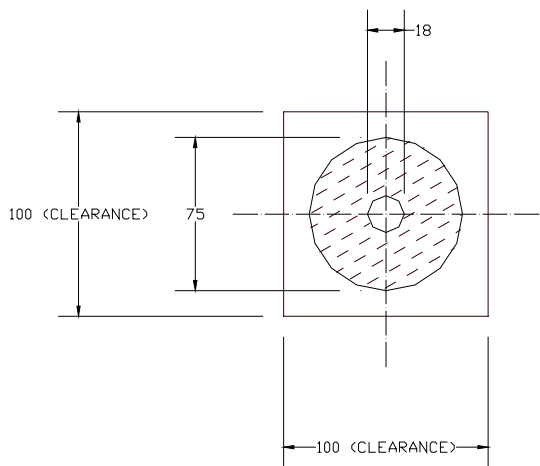

Circle

Unit in um

6 PIN DESCRIPTION

CL

This pin is the system clock input. When internal clock is enabled, this pin should be left open. The internal clock is output from this pin. When internal oscillator is disabled, this pin receives display clock signal from external clock source.

CLS

This is the internal clock enable pin. When it is pulled HIGH, internal clock is enabled. When it is pulled LOW, the internal clock is disabled, an external clock source must be connected to the CL pin for normal operation.

BS0, BS1, BS2

These are MCU interface input selection pins. See the following table for selecting different interfaces:

	6800-parallel interface	8080-parallel interface	Serial interface
BS0	0	0	0
BS1	0	1	0
BS2	1	1	0

CS#

This pin is the chip select input. The chip is enabled for MCU communication only when CS# had been pulled low.

RES#

This is a reset signal input pin. When it is pulled LOW, initialization of the chip is executed.

D/C

This is the Data/Command control pin. When it is pulled HIGH, the input at D₇-D₀ is treated as display data. When it is pulled LOW, the input at D₇-D₀ is transferred to the command registers. For detail relationship to MCU interface signals, please refer to the Timing Characteristics Diagrams.

R/W (WR#)

This is a MCU interface input pin. When 6800-series Parallel Interface mode is selected, this pin is used as Read/Write (R/W) selection input. Pull this pin to HIGH for read mode and pull it to LOW for write mode. When 8080-series Parallel Interface mode is selected, this pin is used as Write (WR#) selection input. Pull this pin to LOW for write mode. Data write operation is initiated when this pin is pulled LOW and the CS# is pulled LOW.

E (RD#)

This is a MCU interface input pin. When 6800-series Parallel Interface is selected, this pin is used as Enable (E) signal. Read/Write operation is initiated when this pin is pulled HIGH and the CS# pin is pulled LOW. When 8080-series Parallel Interface is selected, this pin is used to receive the Read Data (RD#) signal. Data read operation is initiated when this pin is pulled LOW and CS# pin is pulled LOW.

D₇-D₀

These are 8-bit bi-directional data bus to be connected to the microprocessor's data bus. When serial interface mode is selected, D₁ will be the serial data input, SDIN, D₀ will be the serial clock input, SCLK, and D₂ should be left opened.

VDD

This is a voltage supply pin. It must be connected to external source.

VSS

This is a ground pin. It also acts as a reference for the logic pins and the OLED driving voltages. It must be connected to external ground.

BGGND

This is a ground pin for analog circuits. It must be connected to external ground

VCC

This is the most positive voltage supply pin of the chip. It should be supplied externally.

VREF

This is a voltage reference pin for pre-charge voltage in driving OLED device. Voltage should be set to match with the OLED driving voltage in current drive phase. It can either be supplied externally or by connecting to VCC.

IREF

This is a segment current reference pin. A resistor should be connected between this pin and V_{SS} . Set the current at 10uA.

VCOMH

This is an input pin for the voltage output high level for COM signals. A capacitor should be connected between this pin and VSS.

VDDB This is a power supply pin for the internal buffer of the DC-DC voltage converter. It must be connected to V_{DD} when the converter is used.

VSSB

This is a ground pin for the internal buffer of the DC-DC voltage converter. It must be connected to V_{SS} when the converter is used.

GDR

This is an output pin drives the gate of the external NMOS of the booster circuit.

RESE

This is a source current pin of the external NMOS of the booster circuit.

VB_{REF}

This is an internal voltage reference pin for booster circuit. A stabilization capacitor, typ. 1uF, should be connected to Vss.

FB

This is a feedback resistor input pin for the booster circuit. It is used to adjust the booster output voltage level, Vcc.

COM0-COM63

These are pins provided the Common switch signals to the OLED panel. They are in high impedance state when display is OFF.

SEG0-SEG131

These are pins provided the Segment switch signals to the OLED panel. They are in high impedance stage when display is OFF.

TR0-TR8, GPIO0, GPIO1, ICAS, M and DOF#

These are reserved pins. No connection necessary and should be left open individually.

VSL

This is a segment voltage reference pin. This pin should be connected to VSS externally.

VCL

This is a common voltage reference pin. This pin should be connected to VSS externally.

M/S

This pin must be connected to VDD to enable the chip.

NC

Dummy pad. Do not group or short NC pins together.

7 FUNCTIONAL BLOCK DESCRIPTIONS

7.1 Oscillator Circuit and Display Time Generator

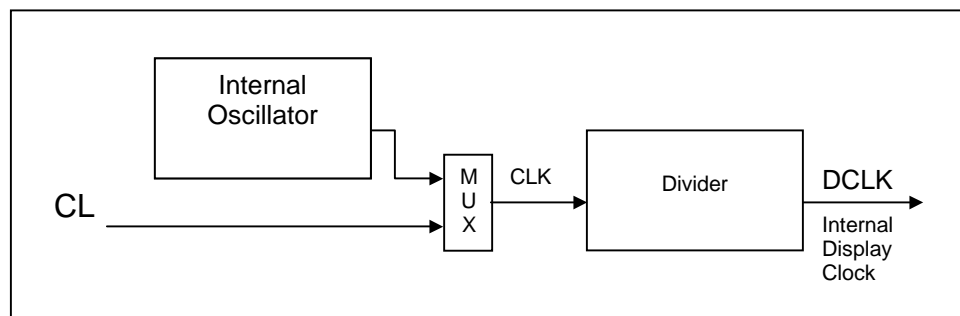

Figure 4 - Oscillator Circuit

This module is an On-Chip low power RC oscillator circuitry (Figure 4). The oscillator generates the clock for the Display Timing Generator.

7.2 Reset Circuit

When RES# pin is pulled LOW, the chip is initialized with the following status:

1. Display is OFF
2. 132 x 64 Display Mode
3. Normal segment and display data column address and row address mapping (SEG0 is mapped to column address 00H and COM0 is mapped to row address 00H)
4. Shift register data clear in serial interface
5. Display start line is set at display RAM address 0
6. Column address counter is set at 0
7. Normal scan direction of the COM outputs
8. Contrast control register is set at 80H
9. DC/DC enable

7.3 Command Decoder and Command Interface

This module determines whether the input data is interpreted as data or command. When the D/C# pin is pulled HIGH, the inputs at D₇-D₀ are interpreted as data and be written to Graphic Display Data RAM (GDDRAM). When it is pulled LOW, the inputs at D₇-D₀ are interpreted as command, they will be decoded and be written to the corresponding command registers.

7.4 MPU Parallel 6800-series Interface

The parallel interface consists of 8 bi-directional data pins (D₇-D₀), R/W (WR#), E (RD#), D/C, CS#. When the R/W (WR#) pin is pulled HIGH, Read operation from the Graphic Display Data RAM (GDDRAM) or the status register occurs. When the R/W (WR#) pin is pulled LOW, Write operation to Display Data RAM or Internal Command Registers occurs, depending on the status of D/C input. The E (RD#) input serves as data latch signal (clock) when HIGH provided that CS# is LOW. Refer to Parallel Interface Timing Diagram of 6800-series microprocessors.

In order to match the operating frequency of display RAM with that of the microprocessor, some pipeline processing is internally performed, which requires the insertion of a dummy read before the first actual display data read. This is shown in Figure 5 below.

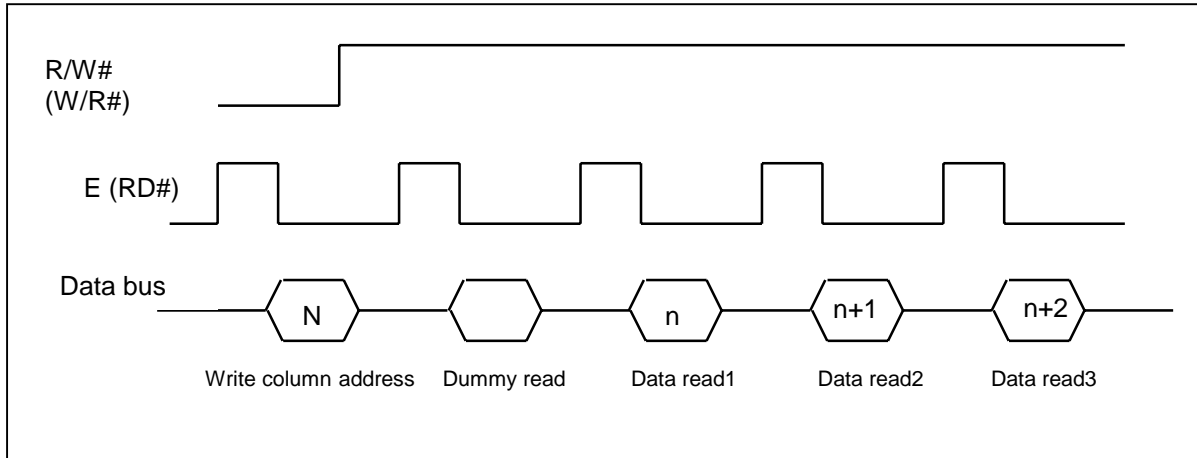

Figure 5 - Display data read back procedure - insertion of dummy read

7.5 MPU Parallel 8080-series Interface

The parallel interface consists of 8 bi-directional data pins (D₇-D₀), R/W (WR#), E (RD#), D/C, CS#. The E (RD#) input serves as data read latch signal (clock) when it is LOW provided that CS# is LOW. Display data or status register read is controlled by D/C signal.

R/W (WR#) input serves as data write latch signal (clock) when it is HIGH and provided that CS# is LOW. Display data or command register write is controlled by D/C. Refer to Parallel Interface Timing Diagram of 8080-series microprocessor. Similar to 6800-series interface, a dummy read is also required before the first actual display data read.

7.6 MPU Serial Interface

The serial interface consists of serial clock SCLK, serial data SDIN, D/C#, CS#. In SPI mode, D0 acts as SCLK, D1 acts as SDIN. For the unused data pins, D2 should be left open. D3 to D7, E and R/W pins can be connected to external ground.

SDIN is shifted into an 8-bit shift register on every rising edge of SCLK in the order of D₇, D₆, ... D₀. D/C# is sampled on every eighth clock and the data byte in the shift register is written to the Display Data RAM or command register in the same clock.

During data writing, an additional NOP command should be inserted before the CS# goes high (Refer to Figure 6).

Figure 6 – Display data write procedure in SPI mode

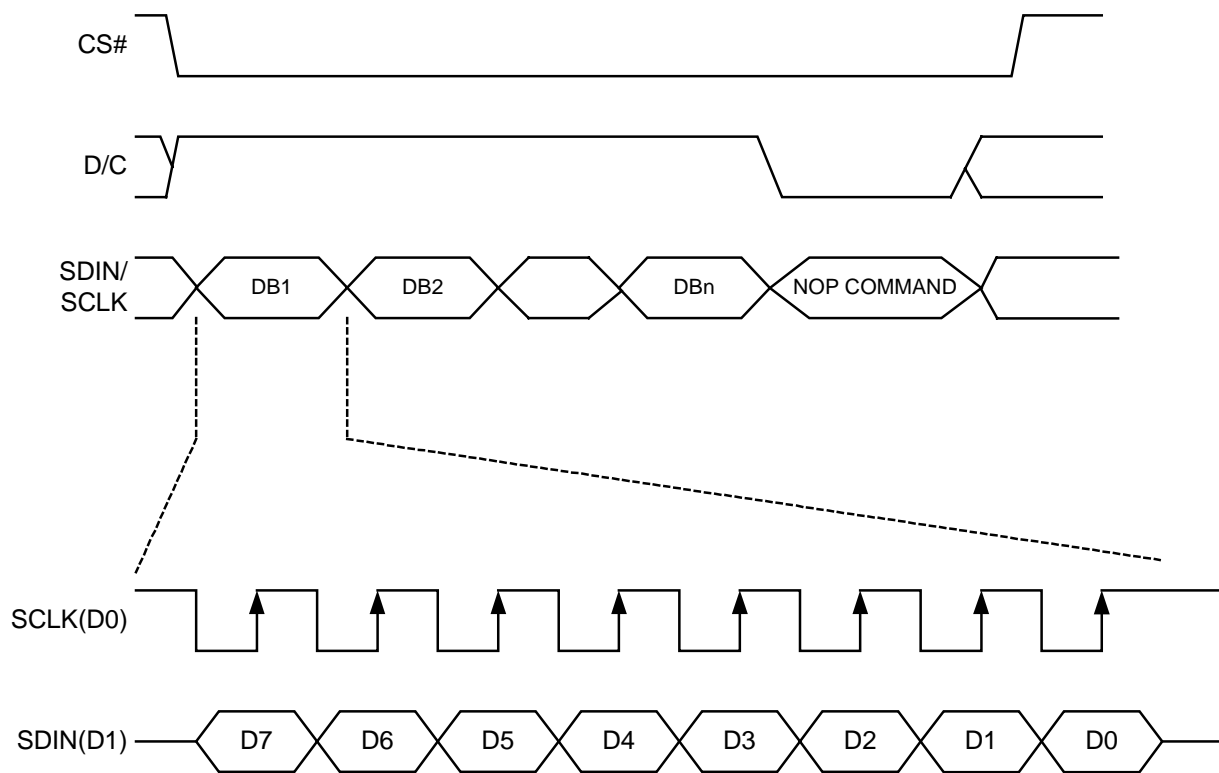

7.7 Graphic Display Data RAM (GDDRAM)

The GDDRAM is a bit mapped static RAM holding the bit pattern to be displayed. The size of the RAM is 132 x 64 bits. For mechanical flexibility, re-mapping on both Segment and Common outputs can be selected by software.

For vertical scrolling of the display, an internal register storing display start line can be set to control the portion of the RAM data to be mapped to the display.

7.8 Current Control and Voltage Control

This block is used to derive the incoming power sources into different levels of internal use voltage and current. VCC and VDD are external power supplies. VREF is reference voltage, which is used to derive the driving voltage for segments and commons. IREF is a reference current source for segment current drivers.

7.9 Segment Drivers / Common Drivers

Segment drivers deliver 132 current sources to drive OLED panel. The driving current can be adjusted from 0 to 300uA with 256 steps. Common drivers generate voltage scanning pulses.

7.10 Area Colour Decoder

Page 0 and Page 1 of the display are divided into 32 banks. Bank16 and Bank32 comprise of a display area of 12 x 8 pixels. Other banks (0~15 & 17~31) have matrices of 8 x 8 pixels. Each bank can be programmed to any one of the four colours (colour A, B, C, D). Detailed operation can be referred to the Command Table.

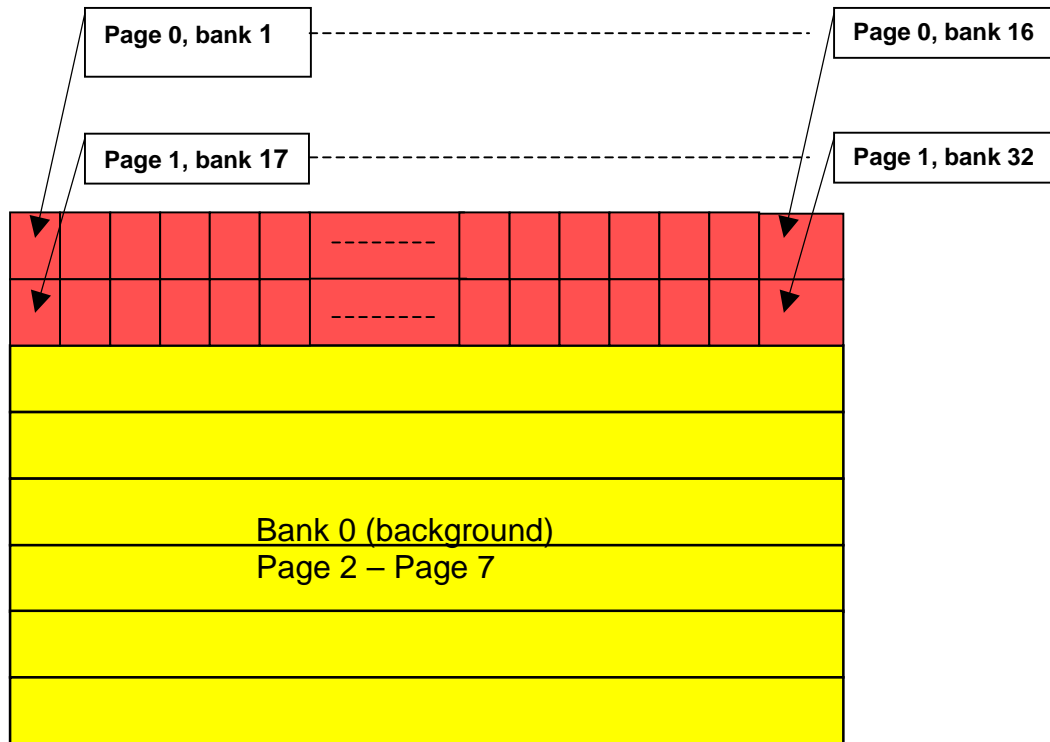

7.11 DC-DC Voltage Converter

It is a switching voltage generator circuit, designed for handheld applications. In SSD1303, internal DC-DC voltage converter accompanying with an external application circuit (shown in below figure) can generate a high voltage supply V_{CC} from a low voltage supply input V_{DD} . V_{CC} is the voltage supply to the OLED driver block. Below application circuit is an example for the input voltage of 3V V_{DD} to generate V_{CC} of 12V @0mA ~ 20mA application.

Figure 7 - DC-DC voltage converter circuit

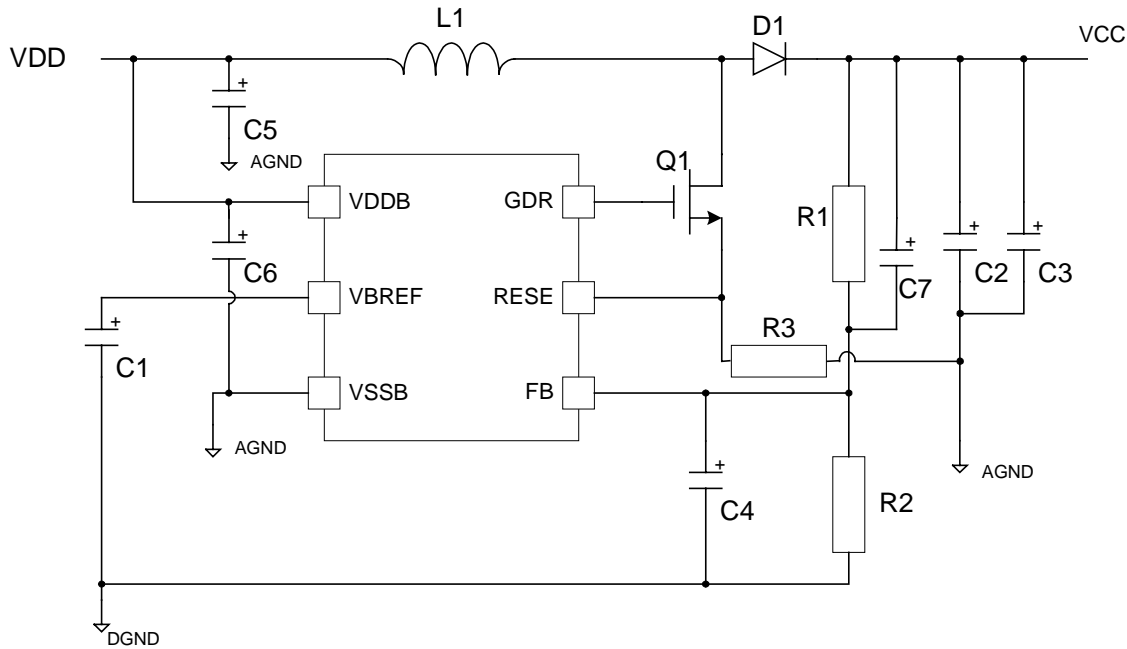

Remark:

1. VSSB is tied to VSS on SSD1303T3 package.
2. L1, D1, Q1, C5 should be grouped closed together on PCB layout.
3. R1, R2, C1, C4 should be grouped closed together on PCB layout.
4. The VCC output voltage level can be adjusted by R1 and R2, the reference formula is:

$$V_{CC} = 1.2 \times (R1 + R2) / R2$$
 The value of (R1+R2) should be between 500k to 1M Ohm.

Table 3 - Passive component selection:

Components	Typical Value	Remark
L1	Inductor, 10 μ H	1A
D1	Schottky diode	1A, 25V e.g. 1N5822, BAT54 [Philips Semiconductors]
Q1	MOSFET	N-FET with low $R_{DS(on)}$ and low V_{th} voltage. e.g. MGSF1N02LT1 [ON SEMI]
R1, R2	Resistor	1%, 1/10W
R3	Resistor, 1.2 Ω	1%, 1/2W
C1	Capacitor, 1 μ F	16V
C2	Capacitor, 6.8 μ F	Low ESR, 25V
C3	Capacitor, 1 μ F	16V
C4	Capacitor, 10nF	16V
C5	Capacitor, 1 ~ 10 μ F	16V
C6	Capacitor, 0.1 ~ 1 μ F	16V
C7	Capacitor, 15nF	16V

8 COMMAND TABLE

Table 4 - Command table

(D/C =0, R/W (WR#)=0, E (RD#)=1)

Note: commands marked with “**” are compatible to SSD1301

D/C	Hex	D7	D6	D5	D4	D3	D2	D1	D0	Command	Description
0	00-0F	0	0	0	0	X ₃	X ₂	X ₁	X ₀	Set Lower Column Address **	Set the lower nibble of the column address register using X ₃ X ₂ X ₁ X ₀ as data bits. The initial display line register is reset to 0000b after POR.
0	10-1F	0	0	0	1	X ₃	X ₂	X ₁	X ₀	Set Higher Column Address **	Set the higher nibble of the column address register using X ₃ X ₂ X ₁ X ₀ as data bits. The initial display line register is reset to 0000b after POR.
0	26	0	0	1	0	0	1	1	0	Horizontal scroll setup	A[2:0] Set the number of column scroll per step Valid value: 001b, 010b, 011b, 100b B[2:0] Define start page address C[1:0] Set time interval between each scroll step in terms of frame frequency 00b – 12 frame 01b – 64 frames 10b – 128 frames 11b – 256 frames D[2:0] Define end page address Set the value of D[2:0] larger or equal to B[2:0]
0	A[2:0]	*	*	*	*	*	A ₂	A ₁	A ₀		
0	B[2:0]	*	*	*	*	*	B ₂	B ₁	B ₀		
0	C[1:0]	*	*	*	*	*	*	C ₁	C ₀		
0	D[2:0]	*	*	*	*	*	D ₂	D ₁	D ₀		
0	2F	0	0	1	0	1	1	1	1	Activate horizontal scroll	Start horizontal scrolling
0	2E	0	0	1	0	1	1	1	0	Deactivate horizontal scroll	Stop horizontal scrolling
0	40-7F	0	1	X ₅	X ₄	X ₃	X ₂	X ₁	X ₀	Set Display Start Line	Set display TAM display start line register from 0-63 using X ₅ X ₃ X ₂ X ₁ X ₀ . Display start line register is reset to 000000 during POR
0	81	1	0	0	0	0	0	0	1	Set Contrast Control Register **	Double byte command to select 1 out of 256 contrast steps. Contrast increases as the value increases. (POR = 80h)
0	A[7:0]	A ₇	A ₆	A ₅	A ₄	A ₃	A ₂	A ₁	A ₀		
0	82	1	0	0	0	0	0	1	0	Brightness for color banks	Double byte command to select 1 out of 256 brightness steps. Brightness increases as the value increases. (POR = 80h)
0	A[7:0]	A ₇	A ₆	A ₅	A ₄	A ₃	A ₂	A ₁	A ₀		
0	91	1	0	0	1	0	0	0	1	Set Look Up Table (LUT) for area colour	Set current drive pulse width of Bank 0, Colour A, B and C. Bank 0: X[5:0] = 0... 63; for pulse width set to 1 ~ 64 clocks (POR = 110001b) Colour A: A[5:0] same as above (POR = 111111b) Colour B: B[5:0] same as above (POR = 111111b) Colour C: C[5:0] same as above (POR = 111111b) Note: colour D pulse width is fixed at 64 clocks pulse .
0	X[5:0]	*	*	X ₅	X ₄	X ₃	X ₂	X ₁	X ₀		
0	A[5:0]	*	*	A ₅	A ₄	A ₃	A ₂	A ₁	A ₀		
0	B[5:0]	*	*	B ₅	B ₄	B ₃	B ₂	B ₁	B ₀		
0	C[5:0]	*	*	C ₅	C ₄	C ₃	C ₂	C ₁	C ₀		

D/C	Hex	D7	D6	D5	D4	D3	D2	D1	D0	Command	Description
0	92	1	0	0	1	0	0	1	0	Set bank colour of for bank 1-16 (Page 0)	A[1:0] : 00, 01, 10, or 11 for Colour = A, B, C or D of bank 1
0	A[7:0]	A ₇	A ₆	A ₅	A ₄	A ₃	A ₂	A ₁	A ₀		A[3:2] : 00, 01, 10, or 11 for Colour = A, B, C or D of bank 2
0	B[7:0]	B ₇	B ₆	B ₅	B ₄	B ₃	B ₂	B ₁	B ₀		:
0	C[7:0]	C ₇	C ₆	C ₅	C ₄	C ₃	C ₂	C ₁	C ₀		:
0	D[7:0]	D ₇	D ₆	D ₅	D ₄	D ₃	D ₂	D ₁	D ₀		D[7:6] : 00, 01, 10, or 11 for Colour = A, B, C or D of bank 16
0	93	1	0	0	1	0	0	1	1	Set bank colour of for bank 17-32 (Page 1)	A[1:0] : 00, 01, 10, or 11 for Colour = A, B, C or D of bank 17
0	A[7:0]	A ₇	A ₆	A ₅	A ₄	A ₃	A ₂	A ₁	A ₀		A[3:2] : 00, 01, 10, or 11 for Colour = A, B, C or D of bank 18
0	B[7:0]	B ₇	B ₆	B ₅	B ₄	B ₃	B ₂	B ₁	B ₀		:
0	C[7:0]	C ₇	C ₆	C ₅	C ₄	C ₃	C ₂	C ₁	C ₀		:
0	D[7:0]	D ₇	D ₆	D ₅	D ₄	D ₃	D ₂	D ₁	D ₀		D[7:6] : 00, 01, 10, or 11 for Colour = A, B, C or D of bank 32
0	A0~ A1	1	0	1	0	0	0	0	X ₀	Set Segment Re-map **	X ₀ =0: column address 0 is mapped to SEG0 (POR) X ₀ =1: column address 131 is mapped to SEG0
0	A4~A5	1	0	1	0	0	1	0	X ₀	Set Entire Display ON/OFF **	X ₀ =0: normal display (POR) X ₀ =1: entire display ON
0	A6~A7	1	0	1	0	0	1	1	X ₀	Set Normal/Inverse Display **	X ₀ =0: normal display (POR) X ₀ =1: inverse display
0	A8	1	0	1	0	1	0	0	0	Set Multiplex Ratio **	The next command, A[5:0] determines multiplex ratio N from 16MUX-64MUX, POR= 64MUX
0	A[5:0]	*	*	A ₅	A ₄	A ₃	A ₂	A ₁	A ₀		
0	AA	1	0	1	0	1	0	1	0	NOP	Reserved, do not use
0	AB	1	0	1	0	1	0	1	1	NOP	Reserved, do not use
0	AD	1	0	1	0	1	1	0	1	Set DC-DC on/off	X ₀ : 1 DC-DC will be turned on when display on (POR) 0 DC-DC is disable
0		1	0	0	0	1	0	1	X ₀		
0	AE~AF	1	0	1	0	1	1	1	X ₀	Set Display ON/OFF **	X ₀ =0: turns OFF OLED panel (POR) X ₀ =1: turns ON OLED panel
0	B0~BF	1	0	1	1	X ₃	X ₂	X ₁	X ₀	Set Page Address **	Set GDDRAM Page Address (0~7) for read/write using X ₃ X ₂ X ₁ X ₀
0	C0/C8	1	1	0	0	X ₃	*	*	*	Set COM Output Scan Direction **	X ₃ =0: normal mode (POR) Scan from COM 0 to COM [N -1] X ₃ =1: remapped mode. Scan from COM [N-1] to COM0 Where N is the Multiplex ratio.
0	D0-D1	1	1	0	1	0	0	0	X ₀	Reserved	Reserved, do not use

D/C	Hex	D7	D6	D5	D4	D3	D2	D1	D0	Command	Description
0 0	D3 A[5:0]	1 *	1 *	0 A ₅	1 A ₄	0 A ₃	0 A ₂	1 A ₁	1 A ₀	Set Display Offset **	Set vertical scroll by COM from 0-63. The value is reset to 00H after POR.
0 0	D5 A[7:0]	1 A ₇	1 A ₆	0 A ₅	1 A ₄	0 A ₃	1 A ₂	0 A ₁	1 A ₀	Set Display Clock Divide Ratio/Oscillator Frequency	A[3:0] Define the divide ratio of the display clocks (DCLK): Divide ratio= A[3:0] + 1, POR is 0000b (divide ratio = 1) A[7:4] Set the Oscillator Frequency. Oscillator Frequency increases with the value of A[7:4] and vice versa. POR is 0111b
0 0	D8	1 0	1 0	0 X ₅	1 X ₄	1 0	0 X ₂	0 0	0 X ₀	Set area colour mode on/off & low power display mode	X ₅ X ₄ = 00 (POR) : mono mode X ₅ X ₄ = 11 Area Colour enable X ₂ =0 and X ₀ =0: Normal (POR) power mode X ₂ =1 and X ₀ =1: Set low power save mode
0 0	D9 A[7:0]	1 A ₇	1 A ₆	0 A ₅	1 A ₄	1 A ₃	0 A ₂	0 A ₁	1 A ₀	Set Pre-charge period**	A[3:0] Phase 1 period of up to 15 dclk clocks [POR=2h]; 0 is invalid entry A[7:4] Phase 2 period of up to 15 dclk clocks [POR=2h]; 0 is invalid entry
0 0	DA	1 0	1 0	0 0	1 X ₄	1 0	0 0	1 1	0 0	Set COM pins hardware configuration	X ₄ =0, Sequential COM pin configuration (i.e. COM31, 30, 29....0 ; SEG0-132; COM31,32....62,63) X ₄ =1(POR), Alternative COM pin configuration (i.e. COM62,60,58,...2,0; SEG0-132; COM1,3,5...61,63)
0 0	DB A[6:0]	1 *	1 A ₆	0 A ₅	1 A ₄	1 A ₃	0 A ₂	1 A ₁	1 A ₀	Set VCOM Deselect Level	A[6:0] 0000000 low VCOM deselect level (~ 0.43 Vref) 0110101 normal VCOM deselect level (~ 0.77*Vref (POR)) 1111111 high VCOM deselect level (equal Vref)
0	E2	1	1	1	0	0	0	1	0	Reserved	Reserved
0	E3	1	1	1	0	0	0	1	1	NOP **	Command for No Operation
0	F*	1	1	1	1	*	*	*	*	Reserved	Reserved, do not use

Note: Remark “**” stands for “Don’t Care”

Table 5 - Read command table

(D/C=0, R/W (WR#)=1, E (RD#)=1 for 6800 or E (RD#)=0 for 8080)

Bit Pattern	Command	Description
D ₇ D ₆ D ₅ D ₄ D ₃ D ₂ D ₁ D ₀	Status Register Read *	D ₇ : Reserve D ₆ : "1" for display OFF / "0" for display ON D ₅ : Reserve D ₄ : Reserve D ₃ : Reserve D ₂ : Reserve D ₁ : Reserve D ₀ : Reserve

Note: Patterns other than that given in Command Table are prohibited to enter to the chip as a command; otherwise, unexpected result will occur.

8.1 Data Read / Write

To read data from the GDDRAM, input HIGH to R/W (WR#) pin and D/C pin for 6800-series parallel mode, LOW to E (RD#) pin and HIGH to D/C# pin for 8080-series parallel mode. No data read is provided in serial mode operation.

In normal data read mode, GDDRAM column address pointer will be increased by one automatically after each data read.

Also, a dummy read is required before the first data read. See Figure 5 in Functional Block Description.

To write data to the GDDRAM, input LOW to R/W (WR#) pin and HIGH to D/C pin for 6800-series parallel mode AND 8080-series parallel mode. For serial interface mode, it is always in write mode. GDDRAM column address pointer will be increased by one automatically after each data write.

Table 6 - Address increment table (Automatic)

D/C	R/W (WR#)	Comment	Address Increment
0	0	Write Command	No
0	1	Read Status	No
1	0	Write Data	Yes
1	1	Read Data	Yes*1

*1. If read-data command is issued in read-modify-write mode, address increase is not applied.

9 COMMAND DESCRIPTIONS

Set Lower Column Address

This command specifies the lower nibble of the 8-bit column address of the display data RAM. The column address will be incremented by each data access after it is pre-set by the MCU.

Set Higher Column Address

This command specifies the higher nibble of the 8-bit column address of the display data RAM. The column address will be incremented by each data access after it is pre-set by the MCU.

Activate Horizontal Scroll

Start motion of horizontal scrolling. This command should only be issued after Horizontal scroll setup parameters are defined.

The following actions are prohibited after the horizontal scroll is activated

1. RAM access (Data write or read)
2. Changing horizontal scroll setup parameters

The SSD1303 horizontal scroll is designed for 128 columns scrolling only. 4 remaining columns are reserved for computation and should be left open.

With column address 0 mapped to SEG0 (Segment remap setting = A0h), the 4 unused columns will be SEG128, SEG129, SEG130, SEG131.

With column address 0 mapped to SEG131 (Segment remap setting = A1h), the 4 unused columns will be SEG0, SEG1, SEG2, SEG3.

Figure 8 - Horizontal scroll direction

REMAP SETTING	SEG0	SEG1	SEG2	SEG3	SEG4	SEG5	SEG126	SEG127	SEG128	SEG129	SEG130	SEG131
A0	A	B	C	D	E	F	→	→	→	Y	Z	Invalid data			
A1	Invalid data				Z	Y	←	←	←	F	E	D	C	B	A

Scroll direction

Deactivate Horizontal Scroll

Stop motion of horizontal scrolling.

Horizontal Scroll Setup

This command consists of 5 consecutive bytes to set up the horizontal scroll parameters. It determines the scrolling start page, end page and the scrolling speed.

Before issuing this command, the horizontal scroll must be deactivated (2Eh). Otherwise, ram content may be corrupted.

Set Display Start Line

This command is to set Display Start Line register to determine starting address of display RAM to be displayed by selecting a value from 0 to 63. With value equals to 0, D₀ of Page 0 is mapped to COM0. With value equals to 1, D₁ of Page0 is mapped to COM0. The display start line values of 0 to 63 are assigned to Page 0 to 7.

Set Contrast Control Register

This command is to set Contrast Setting of the display. The chip has 256 contrast steps from 00 to FF. The segment output current increases as the contrast step value increases. See Figure 9.

Figure 9 - Segment current vs Contrast setting

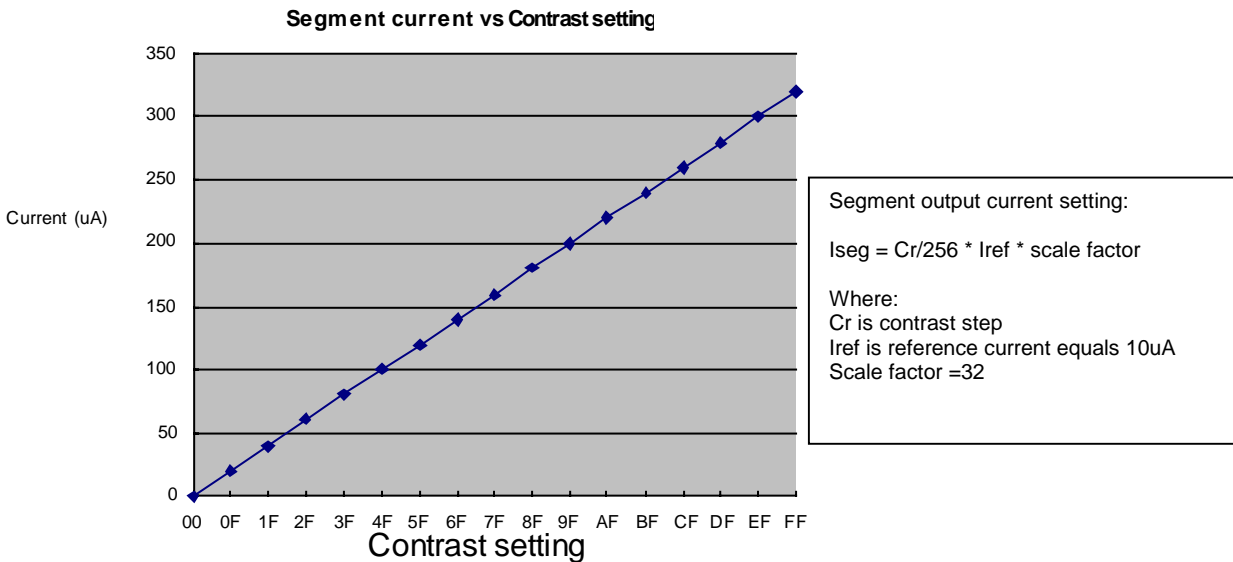

Set Brightness for Color Banks

This command is to set Brightness Setting of the display for area colors banks (except bank 0). The chip has 256 brightness steps from 00 to FF. The segment output current increases as the brightness step value increases

Set Look Up Table (LUT) for area colour

SSD1303 provides 4 colour (pulse width) settings - Colour A, B, C and D. The colour intensity (or grey scale) is defined by the current drive pulse width. The pulse width of colour A, B, C can be programmable from 1 to 64 DCLK* duration. The colour D is fixed at 64 DCLK pulse width. This colour setting has to be stored in the Look Up Table (LUT).

For the background colour, the colour intensity is defined by a variable X[5:0].

Set LUT command: 10010001
 X[5:0]
 A[5:0]
 B[5:0]
 C[5:0]

	Description	Number of DCLKs
Bank 0	Set background colour	X[5:0]
Colour A	Set Pulse Width A	A[5:0]
Colour B	Set Pulse Width B	B[5:0]
Colour C	Set Pulse Width C	C[5:0]
Colour D	Pulse width D is fixed to 64 DCLK	64 (fixed)

DCLK: Internal Display Clock

Set bank colour of bank 1-16 (Page 0) and bank colour of bank 17-32 (Page 1)

Next step is to define the colour of each display area. The 132x64 display matrix is divided into 8 pages of 8 commons per pages. The first two pages, page 0 and page 1, are divided into 32 banks: Bank16 and Bank32 comprise of a display area of 12x8 pixels. Other banks (0~15 & 17~31) have matrices of 8x8 pixels. Each bank can be programmable to any 1 of the 4 colour (A, B, C, D). User can use 92h and 93h command for the bank colour setting. Note: Only applicable in area colour mode.

Set Segment Re-map

This command changes the mapping between the display data column address and segment driver. It allows flexibility in OLED module design. Refer to Command Table.

Set Entire Display ON/OFF

This command forces the entire display to be "ON" regardless of the contents of the display data RAM. This command has priority over normal/reverse display. This command will be used with "Set Display ON/OFF" command to form a compound command for entering power save mode.

Set Normal/Inverse Display

This command sets the display to be either normal/inverse. In normal display, a RAM data of 1 indicates an "ON" pixel while in inverse display; a RAM data of 0 indicates an "ON" pixel.

Set Multiplex Ratio

This command switches default 63 multiplex mode to any multiplex ratio from 2 to 63. The output pads COM0-COM63 will be switched to corresponding COM signal.

Set DC-DC on/off

This command is to control the DC-DC voltage converter. The converter will be turned on by issuing this command then DISPLAY ON command. The panel display must be off while issuing this command. POR the DC-DC will be turned on.

Set Display ON/OFF

This command turns the display ON or OFF. When the display is OFF, the segment and common output are in high impedance state.

Set Page Address

This command positions the page address from 0 to 7 in GDDRAM. Refer to Command Table.

Set COM Output Scan Direction

This command sets the scan direction of the COM output allowing layout flexibility in OLED module design. In addition, the display will have immediate effect once this command is issued. That is, if this command is sent during normal display, the graphic display will be vertically flipped.

Set Display Offset

This is a double byte command. The next command specifies the mapping of display start line to one of COM0-63 (it is assumed that COM0 is the display start line, display start line register equals to 0).

For example, to move the COM16 towards the COM0 direction for 16 lines, the 6-bit data in the second byte should be given by 010000. To move in the opposite direction by 16 lines, the 6-bit data should be given by (64 – 16) and so the second byte should be 100000.

Hardware pin name	Output												Set MUX ratio(A8) COM Normal / Remapped (C0 / C8) Display offset (D3) Display start line (40 - 7F)
	64		64		64		56		56		56		
	Normal		Normal		Normal		Normal		Normal		Normal		
	0	8	0	8	0	8	0	8	0	8	0	8	
COM0	Row0	RAM0	Row8	RAM8	Row0	RAM8	Row0	RAM0	Row8	RAM8	Row0	RAM8	
COM1	Row1	RAM1	Row9	RAM9	Row1	RAM9	Row1	RAM1	Row9	RAM9	Row1	RAM9	
COM2	Row2	RAM2	Row10	RAM10	Row2	RAM10	Row2	RAM2	Row10	RAM10	Row2	RAM10	
COM3	Row3	RAM3	Row11	RAM11	Row3	RAM11	Row3	RAM3	Row11	RAM11	Row3	RAM11	
COM4	Row4	RAM4	Row12	RAM12	Row4	RAM12	Row4	RAM4	Row12	RAM12	Row4	RAM12	
COM5	Row5	RAM5	Row13	RAM13	Row5	RAM13	Row5	RAM5	Row13	RAM13	Row5	RAM13	
COM6	Row6	RAM6	Row14	RAM14	Row6	RAM14	Row6	RAM6	Row14	RAM14	Row6	RAM14	
COM7	Row7	RAM7	Row15	RAM15	Row7	RAM15	Row7	RAM7	Row15	RAM15	Row7	RAM15	
COM8	Row8	RAM8	Row16	RAM16	Row8	RAM16	Row8	RAM8	Row16	RAM16	Row8	RAM16	
COM9	Row9	RAM9	Row17	RAM17	Row9	RAM17	Row9	RAM9	Row17	RAM17	Row9	RAM17	
COM10	Row10	RAM10	Row18	RAM18	Row10	RAM18	Row10	RAM10	Row18	RAM18	Row10	RAM18	
COM11	Row11	RAM11	Row19	RAM19	Row11	RAM19	Row11	RAM11	Row19	RAM19	Row11	RAM19	
COM12	Row12	RAM12	Row20	RAM20	Row12	RAM20	Row12	RAM12	Row20	RAM20	Row12	RAM20	
COM13	Row13	RAM13	Row21	RAM21	Row13	RAM21	Row13	RAM13	Row21	RAM21	Row13	RAM21	
COM14	Row14	RAM14	Row22	RAM22	Row14	RAM22	Row14	RAM14	Row22	RAM22	Row14	RAM22	
COM15	Row15	RAM15	Row23	RAM23	Row15	RAM23	Row15	RAM15	Row23	RAM23	Row15	RAM23	
COM16	Row16	RAM16	Row24	RAM24	Row16	RAM24	Row16	RAM16	Row24	RAM24	Row16	RAM24	
COM17	Row17	RAM17	Row25	RAM25	Row17	RAM25	Row17	RAM17	Row25	RAM25	Row17	RAM25	
COM18	Row18	RAM18	Row26	RAM26	Row18	RAM26	Row18	RAM18	Row26	RAM26	Row18	RAM26	
COM19	Row19	RAM19	Row27	RAM27	Row19	RAM27	Row19	RAM19	Row27	RAM27	Row19	RAM27	
COM20	Row20	RAM20	Row28	RAM28	Row20	RAM28	Row20	RAM20	Row28	RAM28	Row20	RAM28	
COM21	Row21	RAM21	Row29	RAM29	Row21	RAM29	Row21	RAM21	Row29	RAM29	Row21	RAM29	
COM22	Row22	RAM22	Row30	RAM30	Row22	RAM30	Row22	RAM22	Row30	RAM30	Row22	RAM30	
COM23	Row23	RAM23	Row31	RAM31	Row23	RAM31	Row23	RAM23	Row31	RAM31	Row23	RAM31	
COM24	Row24	RAM24	Row32	RAM32	Row24	RAM32	Row24	RAM24	Row32	RAM32	Row24	RAM32	
COM25	Row25	RAM25	Row33	RAM33	Row25	RAM33	Row25	RAM25	Row33	RAM33	Row25	RAM33	
COM26	Row26	RAM26	Row34	RAM34	Row26	RAM34	Row26	RAM26	Row34	RAM34	Row26	RAM34	
COM27	Row27	RAM27	Row35	RAM35	Row27	RAM35	Row27	RAM27	Row35	RAM35	Row27	RAM35	
COM28	Row28	RAM28	Row36	RAM36	Row28	RAM36	Row28	RAM28	Row36	RAM36	Row28	RAM36	
COM29	Row29	RAM29	Row37	RAM37	Row29	RAM37	Row29	RAM29	Row37	RAM37	Row29	RAM37	
COM30	Row30	RAM30	Row38	RAM38	Row30	RAM38	Row30	RAM30	Row38	RAM38	Row30	RAM38	
COM31	Row31	RAM31	Row39	RAM39	Row31	RAM39	Row31	RAM31	Row39	RAM39	Row31	RAM39	
COM32	Row32	RAM32	Row40	RAM40	Row32	RAM40	Row32	RAM32	Row40	RAM40	Row32	RAM40	
COM33	Row33	RAM33	Row41	RAM41	Row33	RAM41	Row33	RAM33	Row41	RAM41	Row33	RAM41	
COM34	Row34	RAM34	Row42	RAM42	Row34	RAM42	Row34	RAM34	Row42	RAM42	Row34	RAM42	
COM35	Row35	RAM35	Row43	RAM43	Row35	RAM43	Row35	RAM35	Row43	RAM43	Row35	RAM43	
COM36	Row36	RAM36	Row44	RAM44	Row36	RAM44	Row36	RAM36	Row44	RAM44	Row36	RAM44	
COM37	Row37	RAM37	Row45	RAM45	Row37	RAM45	Row37	RAM37	Row45	RAM45	Row37	RAM45	
COM38	Row38	RAM38	Row46	RAM46	Row38	RAM46	Row38	RAM38	Row46	RAM46	Row38	RAM46	
COM39	Row39	RAM39	Row47	RAM47	Row39	RAM47	Row39	RAM39	Row47	RAM47	Row39	RAM47	
COM40	Row40	RAM40	Row48	RAM48	Row40	RAM48	Row40	RAM40	Row48	RAM48	Row40	RAM48	
COM41	Row41	RAM41	Row49	RAM49	Row41	RAM49	Row41	RAM41	Row49	RAM49	Row41	RAM49	
COM42	Row42	RAM42	Row50	RAM50	Row42	RAM50	Row42	RAM42	Row50	RAM50	Row42	RAM50	
COM43	Row43	RAM43	Row51	RAM51	Row43	RAM51	Row43	RAM43	Row51	RAM51	Row43	RAM51	
COM44	Row44	RAM44	Row52	RAM52	Row44	RAM52	Row44	RAM44	Row52	RAM52	Row44	RAM52	
COM45	Row45	RAM45	Row53	RAM53	Row45	RAM53	Row45	RAM45	Row53	RAM53	Row45	RAM53	
COM46	Row46	RAM46	Row54	RAM54	Row46	RAM54	Row46	RAM46	Row54	RAM54	Row46	RAM54	
COM47	Row47	RAM47	Row55	RAM55	Row47	RAM55	Row47	RAM47	Row55	RAM55	Row47	RAM55	
COM48	Row48	RAM48	Row56	RAM56	Row48	RAM56	Row48	RAM48	-	-	Row48	RAM56	
COM49	Row49	RAM49	Row57	RAM57	Row49	RAM57	Row49	RAM49	-	-	Row49	RAM57	
COM50	Row50	RAM50	Row58	RAM58	Row50	RAM58	Row50	RAM50	-	-	Row50	RAM58	
COM51	Row51	RAM51	Row59	RAM59	Row51	RAM59	Row51	RAM51	-	-	Row51	RAM59	
COM52	Row52	RAM52	Row60	RAM60	Row52	RAM60	Row52	RAM52	-	-	Row52	RAM60	
COM53	Row53	RAM53	Row61	RAM61	Row53	RAM61	Row53	RAM53	-	-	Row53	RAM61	
COM54	Row54	RAM54	Row62	RAM62	Row54	RAM62	Row54	RAM54	-	-	Row54	RAM62	
COM55	Row55	RAM55	Row63	RAM63	Row55	RAM63	Row55	RAM55	-	-	Row55	RAM63	
COM56	Row56	RAM56	Row0	RAM0	Row56	RAM0	-	-	Row0	RAM0	-	-	
COM57	Row57	RAM57	Row1	RAM1	Row57	RAM1	-	-	Row1	RAM1	-	-	
COM58	Row58	RAM58	Row2	RAM2	Row58	RAM2	-	-	Row2	RAM2	-	-	
COM59	Row59	RAM59	Row3	RAM3	Row59	RAM3	-	-	Row3	RAM3	-	-	
COM60	Row60	RAM60	Row4	RAM4	Row60	RAM4	-	-	Row4	RAM4	-	-	
COM61	Row61	RAM61	Row5	RAM5	Row61	RAM5	-	-	Row5	RAM5	-	-	
COM62	Row62	RAM62	Row6	RAM6	Row62	RAM6	-	-	Row6	RAM6	-	-	
COM63	Row63	RAM63	Row7	RAM7	Row63	RAM7	-	-	Row7	RAM7	-	-	

Hardware pin name	Output												Set MUX ratio(A8)	
	64		64		64		48		48		48		COM Normal / Remapped (C0 / C8)	
	Remap		Remap		Remap		Remap		Remap		Remap		Display offset (D3)	
	0		8		0		0		8		0		8	
	0		0		8		0		8		16		Display start line (40 - 7F)	
COM0	Row63	RAM63	Row7	RAM7	Row63	RAM7	Row47	RAM47	-	-	Row47	RAM41	-	-
COM1	Row62	RAM62	Row6	RAM6	Row62	RAM6	Row46	RAM46	-	-	Row46	RAM40	-	-
COM2	Row61	RAM61	Row5	RAM5	Row61	RAM5	Row45	RAM45	-	-	Row45	RAM41	-	-
COM3	Row60	RAM60	Row4	RAM4	Row60	RAM4	Row44	RAM44	-	-	Row44	RAM42	-	-
COM4	Row59	RAM59	Row3	RAM3	Row59	RAM3	Row43	RAM43	-	-	Row43	RAM43	-	-
COM5	Row58	RAM58	Row2	RAM2	Row58	RAM2	Row42	RAM42	-	-	Row42	RAM44	-	-
COM6	Row57	RAM57	Row1	RAM1	Row57	RAM1	Row41	RAM41	-	-	Row41	RAM45	-	-
COM7	Row56	RAM56	Row0	RAM0	Row56	RAM0	Row40	RAM40	-	-	Row40	RAM46	-	-
COM8	Row55	RAM55	Row63	RAM63	Row55	RAM63	Row39	RAM39	Row47	RAM47	Row39	RAM47	Row47	RAM63
COM9	Row54	RAM54	Row62	RAM62	Row54	RAM62	Row38	RAM38	Row46	RAM46	Row38	RAM46	Row46	RAM62
COM10	Row53	RAM53	Row61	RAM61	Row53	RAM61	Row37	RAM37	Row45	RAM45	Row37	RAM45	Row45	RAM61
COM11	Row52	RAM52	Row60	RAM60	Row52	RAM60	Row36	RAM36	Row44	RAM44	Row36	RAM44	Row44	RAM60
COM12	Row51	RAM51	Row59	RAM59	Row51	RAM59	Row35	RAM35	Row43	RAM43	Row35	RAM43	Row43	RAM59
COM13	Row50	RAM50	Row58	RAM58	Row50	RAM58	Row34	RAM34	Row42	RAM42	Row34	RAM42	Row42	RAM58
COM14	Row49	RAM49	Row57	RAM57	Row49	RAM57	Row33	RAM33	Row41	RAM41	Row33	RAM41	Row41	RAM57
COM15	Row48	RAM48	Row56	RAM56	Row48	RAM56	Row32	RAM32	Row40	RAM40	Row32	RAM40	Row40	RAM56
COM16	Row47	RAM47	Row55	RAM55	Row47	RAM55	Row31	RAM31	Row39	RAM39	Row31	RAM39	Row39	RAM55
COM17	Row46	RAM46	Row54	RAM54	Row46	RAM54	Row30	RAM30	Row38	RAM38	Row30	RAM38	Row38	RAM54
COM18	Row45	RAM45	Row53	RAM53	Row45	RAM53	Row29	RAM29	Row37	RAM37	Row29	RAM37	Row37	RAM53
COM19	Row44	RAM44	Row52	RAM52	Row44	RAM52	Row28	RAM28	Row36	RAM36	Row28	RAM36	Row36	RAM52
COM20	Row43	RAM43	Row51	RAM51	Row43	RAM51	Row27	RAM27	Row35	RAM35	Row27	RAM35	Row35	RAM51
COM21	Row42	RAM42	Row50	RAM50	Row42	RAM50	Row26	RAM26	Row34	RAM34	Row26	RAM34	Row34	RAM50
COM22	Row41	RAM41	Row49	RAM49	Row41	RAM49	Row25	RAM25	Row33	RAM33	Row25	RAM33	Row33	RAM49
COM23	Row40	RAM40	Row48	RAM48	Row40	RAM48	Row24	RAM24	Row32	RAM32	Row24	RAM32	Row32	RAM48
COM24	Row39	RAM39	Row47	RAM47	Row39	RAM47	Row23	RAM23	Row31	RAM31	Row23	RAM31	Row31	RAM47
COM25	Row38	RAM38	Row46	RAM46	Row38	RAM46	Row22	RAM22	Row30	RAM30	Row22	RAM30	Row30	RAM46
COM26	Row37	RAM37	Row45	RAM45	Row37	RAM45	Row21	RAM21	Row29	RAM29	Row21	RAM29	Row29	RAM45
COM27	Row36	RAM36	Row44	RAM44	Row36	RAM44	Row20	RAM20	Row28	RAM28	Row20	RAM28	Row28	RAM44
COM28	Row35	RAM35	Row43	RAM43	Row35	RAM43	Row19	RAM19	Row27	RAM27	Row19	RAM27	Row27	RAM43
COM29	Row34	RAM34	Row42	RAM42	Row34	RAM42	Row18	RAM18	Row26	RAM26	Row18	RAM26	Row26	RAM42
COM30	Row33	RAM33	Row41	RAM41	Row33	RAM41	Row17	RAM17	Row25	RAM25	Row17	RAM25	Row25	RAM41
COM31	Row32	RAM32	Row40	RAM40	Row32	RAM40	Row16	RAM16	Row24	RAM24	Row16	RAM24	Row24	RAM40
COM32	Row31	RAM31	Row39	RAM39	Row31	RAM39	Row15	RAM15	Row23	RAM23	Row15	RAM23	Row23	RAM39
COM33	Row30	RAM30	Row38	RAM38	Row30	RAM38	Row14	RAM14	Row22	RAM22	Row14	RAM22	Row22	RAM38
COM34	Row29	RAM29	Row37	RAM37	Row29	RAM37	Row13	RAM13	Row21	RAM21	Row13	RAM21	Row21	RAM37
COM35	Row28	RAM28	Row36	RAM36	Row28	RAM36	Row12	RAM12	Row20	RAM20	Row12	RAM20	Row20	RAM36
COM36	Row27	RAM27	Row35	RAM35	Row27	RAM35	Row11	RAM11	Row19	RAM19	Row11	RAM19	Row19	RAM35
COM37	Row26	RAM26	Row34	RAM34	Row26	RAM34	Row10	RAM10	Row18	RAM18	Row10	RAM18	Row18	RAM34
COM38	Row25	RAM25	Row33	RAM33	Row25	RAM33	Row9	RAM9	Row17	RAM17	Row9	RAM17	Row17	RAM33
COM39	Row24	RAM24	Row32	RAM32	Row24	RAM32	Row8	RAM8	Row16	RAM16	Row8	RAM16	Row16	RAM32
COM40	Row23	RAM23	Row31	RAM31	Row23	RAM31	Row7	RAM7	Row15	RAM15	Row7	RAM15	Row15	RAM31
COM41	Row22	RAM22	Row30	RAM30	Row22	RAM30	Row6	RAM6	Row14	RAM14	Row6	RAM14	Row14	RAM30
COM42	Row21	RAM21	Row29	RAM29	Row21	RAM29	Row5	RAM5	Row13	RAM13	Row5	RAM13	Row13	RAM29
COM43	Row20	RAM20	Row28	RAM28	Row20	RAM28	Row4	RAM4	Row12	RAM12	Row4	RAM12	Row12	RAM28
COM44	Row19	RAM19	Row27	RAM27	Row19	RAM27	Row3	RAM3	Row11	RAM11	Row3	RAM11	Row11	RAM27
COM45	Row18	RAM18	Row26	RAM26	Row18	RAM26	Row2	RAM2	Row10	RAM10	Row2	RAM10	Row10	RAM26
COM46	Row17	RAM17	Row25	RAM25	Row17	RAM25	Row1	RAM1	Row9	RAM9	Row1	RAM9	Row9	RAM25
COM47	Row16	RAM16	Row24	RAM24	Row16	RAM24	Row0	RAM0	Row8	RAM8	Row0	RAM8	Row8	RAM24
COM48	Row15	RAM15	Row23	RAM23	Row15	RAM23	-	-	Row7	RAM7	-	-	Row7	RAM23
COM49	Row14	RAM14	Row22	RAM22	Row14	RAM22	-	-	Row6	RAM6	-	-	Row6	RAM22
COM50	Row13	RAM13	Row21	RAM21	Row13	RAM21	-	-	Row5	RAM5	-	-	Row5	RAM21
COM51	Row12	RAM12	Row20	RAM20	Row12	RAM20	-	-	Row4	RAM4	-	-	Row4	RAM20
COM52	Row11	RAM11	Row19	RAM19	Row11	RAM19	-	-	Row3	RAM3	-	-	Row3	RAM19
COM53	Row10	RAM10	Row18	RAM18	Row10	RAM18	-	-	Row2	RAM2	-	-	Row2	RAM18
COM54	Row9	RAM9	Row17	RAM17	Row9	RAM17	-	-	Row1	RAM1	-	-	Row1	RAM17
COM55	Row8	RAM8	Row16	RAM16	Row8	RAM16	-	-	Row0	RAM0	-	-	Row0	RAM16
COM56	Row7	RAM7	Row15	RAM15	Row7	RAM15	-	-	-	-	-	-	-	-
COM57	Row6	RAM6	Row14	RAM14	Row6	RAM14	-	-	-	-	-	-	-	-
COM58	Row5	RAM5	Row13	RAM13	Row5	RAM13	-	-	-	-	-	-	-	-
COM59	Row4	RAM4	Row12	RAM12	Row4	RAM12	-	-	-	-	-	-	-	-
COM60	Row3	RAM3	Row11	RAM11	Row3	RAM11	-	-	-	-	-	-	-	-
COM61	Row2	RAM2	Row10	RAM10	Row2	RAM10	-	-	-	-	-	-	-	-
COM62	Row1	RAM1	Row9	RAM9	Row1	RAM9	-	-	-	-	-	-	-	-
COM63	Row0	RAM0	Row8	RAM8	Row0	RAM8	-	-	-	-	-	-	-	-

Set Display Clock Divide Ratio/ Oscillator Frequency

This command is used to set the frequency of the internal display clocks, DCLKs. It is defined as the divide ratio (Value from 1 to 16) used to divide the oscillator frequency. POR is 1. Frame frequency is determined by divide ratio, number of display clocks per row, MUX ratio and oscillator frequency.

Set Area Colour Mode ON/OFF

This command is used to enable area colour mode. POR is mono mode.

Set Low Power Display Mode

This is a double byte command. This command is set to reduce power consumption during IC operation.

Set Pre-charge period

This command is used to set the duration of the pre-charge period. The interval is counted in number of DCLK. POR is 2 DCLK.

Set COM pins hardware configuration

This command is to set the COM signals pin configuration (sequential or alternative) to match the OLED panel hardware layout

Sequential COM pin configuration:

COM31, 30, 29...0	SEG0, 1, 2... 131	COM32, 33, 34...63
-------------------	-------------------	--------------------

Alternative COM pin configuration (POR):

COM62, 60, 58...0	SEG0, 1, 2... 131	COM1, 3, 5...63
-------------------	-------------------	-----------------

Set VCOM deselect level

This command is to set the COM pin output voltage level at deselect stage.

NOP

No Operation Command

Status register Read

This command is issued by setting D/C# LOW during a data read (refer to Figure 10 and Figure 11 for parallel interface waveform). It allows the MCU to monitor the internal status of the chip. No status read is provided for serial mode.

10 MAXIMUM RATINGS

Table 7 - Maximum Ratings

(Voltage Reference to V_{SS})

Symbol	Parameter	Value	Unit
V_{DD}	Supply Voltage	-0.3 to +4.0	V
V_{CC}		0.0 to 18.0	V
V_{REF}		0.0 to 18.0	V
V_{COMH}	Supply Voltage/Output voltage	0.0 to 18.0	V
-	SEG/COM output voltage	0.0 to 18.0	V
V_{in}	Input voltage	$V_{SS}-0.3$ to $V_{DD}+0.3$	V
T_A	Operating Temperature	-40 to +90	°C
T_{stg}	Storage Temperature Range	-65 to +150	°C

Maximum Ratings are those values beyond which damage to the device may occur. Functional operation should be restricted to the limits in the Electrical Characteristics tables or Pin Description.

11 DC CHARACTERISTICS

Table 8 - DC Characteristics

(Unless otherwise specified, Voltage Referenced to V_{SS} , $V_{DD} = 2.4$ to $3.5V$, $T_A = 25^\circ C$)

Symbol	Parameter	Test Condition	Min	Typ	Max	Unit
V_{CC}	Operating Voltage	-	7	12	16	V
V_{DD}	Logic Supply Voltage	-	2.4	-	3.5	V
V_{DD}	Logic Supply Voltage (internal DC/DC enable)	-	3.0	-	3.5	V
V_{OH}	High Logic Output Level	$I_{OUT} = 100\mu A, 3.3MHz$	$0.9 \cdot V_{DD}$	-	V_{DD}	V
V_{OL}	Low Logic Output Level	$I_{OUT} = 100\mu A, 3.3MHz$	0	-	$0.1 \cdot V_{DD}$	V
V_{IH}	High Logic Input Level	$I_{OUT} = 100\mu A, 3.3MHz$	$0.8 \cdot V_{DD}$	-	V_{DD}	V
V_{IL}	Low Logic Input Level	$I_{OUT} = 100\mu A, 3.3MHz$	0	-	$0.2 \cdot V_{DD}$	V
$I_{CC, SLEEP}$	Sleep mode Current	$V_{DD}=2.7V$, display OFF, No panel attached	-10	-	+10	μA
$I_{DD, SLEEP}$	Sleep mode Current	$V_{DD}=2.7V$, display OFF, No panel attached	-10	-	+10	μA
I_{CC}	V_{CC} Supply Current $V_{DD} = 2.7V$, $V_{CC} = 12V$, $I_{REF} = 10\mu A$ No loading, Display ON, All ON	Contrast = FF	-	550	-	μA
I_{DD}	V_{DD} Supply Current $V_{DD} = 2.7V$, $V_{CC} = 12V$, $I_{REF} = 10\mu A$ No loading, Display ON, All ON	Contrast = FF	-	190	-	μA
I_{SEG}	Segment Output Current $V_{DD}=2.7V$, $V_{CC}=12V$, $I_{REF}=10\mu A$, Display ON, Segment pin under test is connected with a 20K resistive load to VSS	Contrast=FF	285	320	355	μA
		Contrast=AF	-	220	-	
		Contrast=5F	-	120	-	
		Contrast=0F	-	20	-	
Dev	Segment output current uniformity	$Dev = (I_{SEG} - I_{MID})/I_{MID}$ $I_{MID} = (I_{MAX} + I_{MIN})/2$ $I_{SEG}[0:131] =$ Segment current at contrast = FF	-	-	± 3	%
Adj. Dev	Adjacent pin output current uniformity (contrast = FF)	$Adj\ Dev = (I[n]-I[n+1]) / (I[n]+I[n+1])$	-	± 2.0	-	%
V_{CC}	DC-DC converter output voltage	V_{DD} input=3V, L=22 μH ; R1=450Kohm; R2=50Kohm; I _{cc} = 20mA (loading)	11.0	12.0	13.0	V
		-	7	-	16	
Pwr	DC-DC converter output power	V_{DD} input=3V, L=22 μH ; $V_{CC} = 12V$	-	-	400	mW

12 AC CHARACTERISTICS

Table 9 - AC Characteristics

(Unless otherwise specified, Voltage Referenced to V_{SS} , $V_{DD} = 2.4$ to $3.5V$, $T_A = 25^\circ C$.)

Symbol	Parameter	Test Condition	Min	Typ	Max	Unit
F_{OSC}	Oscillation Frequency of Display Timing Generator	$V_{dd} = 2.7V$	315	360	420	kHz
F_{FRM}	Frame Frequency for 64 MUX Mode	132x64 Graphic Display Mode, Display ON, Internal Oscillator Enabled	-	$F_{OSC} \times 1/(D \times K \times 64)$	-	Hz
RES#	Reset low pulse width	-	3			us
	Reset complete time	-			2	us

D: divide ratio (default value = 1)

K: number of display clocks (default value = 54)

Refer to command table (set display clock divide ratio/oscillator freq) for detail description

Table 10 - 6800-Series MPU Parallel Interface Timing Characteristics

($V_{DD} - V_{SS} = 2.4$ to $3.5V$, $T_A = 25^\circ C$)

Symbol	Parameter	Min	Typ	Max	Unit
t_{cycle}	Clock Cycle Time	300	-	-	ns
t_{AS}	Address Setup Time	0	-	-	ns
t_{AH}	Address Hold Time	0	-	-	ns
t_{DSW}	Write Data Setup Time	40	-	-	ns
t_{DHW}	Write Data Hold Time	7	-	-	ns
t_{DHR}	Read Data Hold Time	20	-	-	ns
t_{OH}	Output Disable Time	-	-	70	ns
t_{ACC}	Access Time	-	-	140	ns
PW_{CSL}	Chip Select Low Pulse Width (read) Chip Select Low Pulse Width (write)	120 60	-	-	ns
PW_{CSH}	Chip Select High Pulse Width (read) Chip Select High Pulse Width (write)	60 60	-	-	ns
t_R	Rise Time	-	-	15	ns
t_F	Fall Time	-	-	15	ns

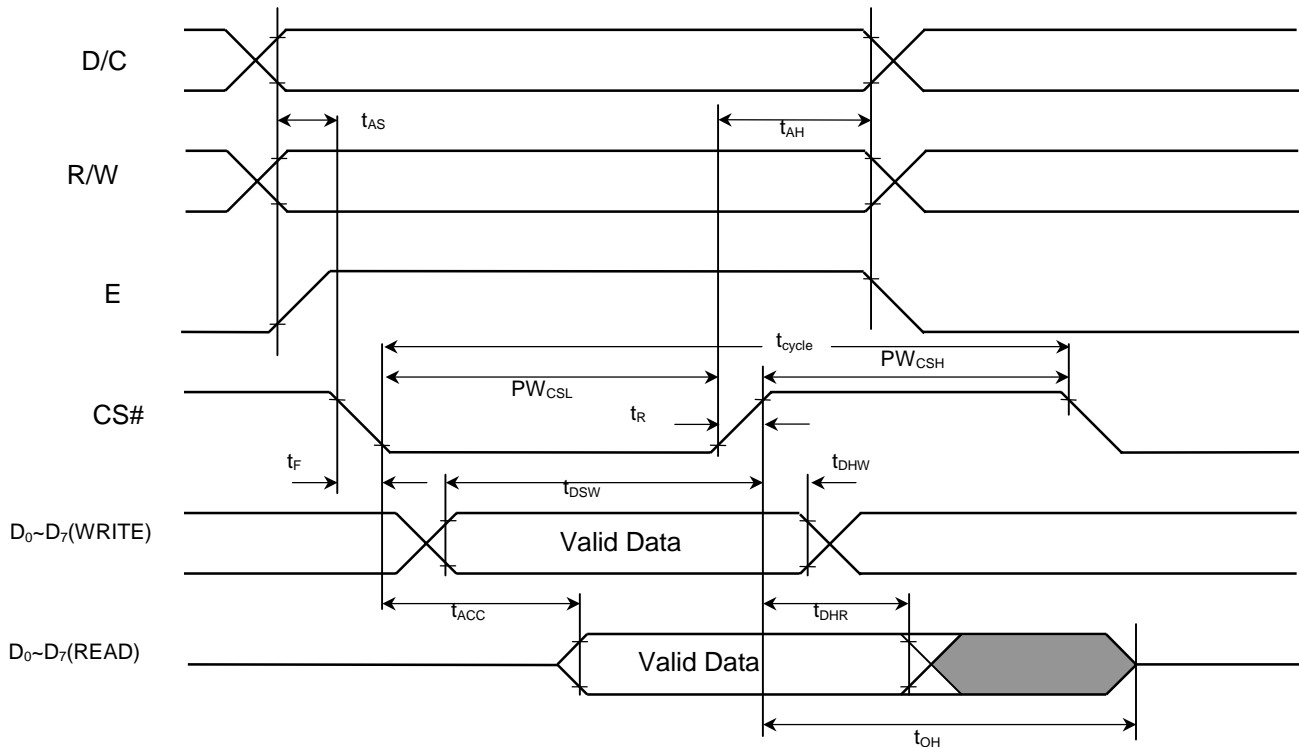

Figure 10 - 6800-series MPU parallel interface characteristics

Table 11 - 8080-Series MPU Parallel Interface Timing Characteristics

($V_{DD} - V_{SS} = 2.4$ to $3.5V$, $T_A = 25^\circ C$)

Symbol	Parameter	Min	Typ	Max	Unit
t_{cycle}	Clock Cycle Time	300	-	-	ns
t_{AS}	Address Setup Time	0	-	-	ns
t_{AH}	Address Hold Time	0	-	-	ns
t_{DSW}	Write Data Setup Time	40	-	-	ns
t_{DHW}	Write Data Hold Time	7	-	-	ns
t_{DHR}	Read Data Hold Time	20	-	-	ns
t_{OH}	Output Disable Time	-	-	70	ns
t_{ACC}	Access Time	-	-	140	ns
PW_{CSL}	Chip Select Low Pulse Width (read)	120	-	-	ns
	Chip Select Low Pulse Width (write)	60	-	-	ns
PW_{CSH}	Chip Select High Pulse Width (read)	60	-	-	ns
	Chip Select High Pulse Width (write)	60	-	-	ns
t_R	Rise Time	-	-	15	ns
t_F	Fall Time	-	-	15	ns

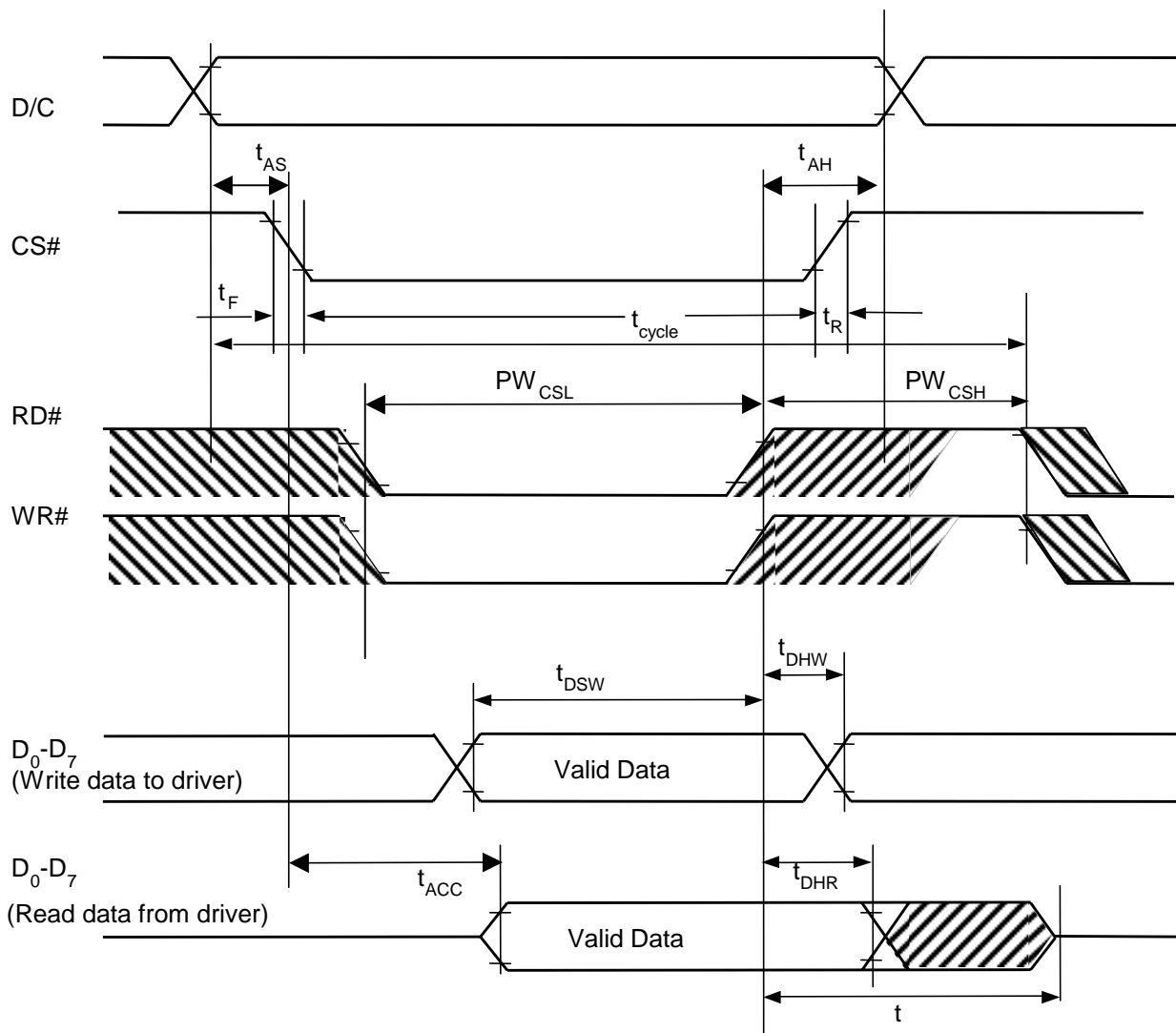

Figure 11 - 8080-series MPU parallel interface characteristics

Table 12 - Serial Interface Timing Characteristics

($V_{DD} - V_{SS} = 2.4$ to $3.5V$, $T_A = 25^\circ C$)

Symbol	Parameter	Min	Typ	Max	Unit
t_{cycle}	Clock Cycle Time	250	-	-	ns
t_{AS}	Address Setup Time	150	-	-	ns
t_{AH}	Address Hold Time	150	-	-	ns
t_{CSS}	Chip Select Setup Time	120	-	-	ns
t_{CSH}	Chip Select Hold Time	60	-	-	ns
t_{DSW}	Write Data Setup Time	100	-	-	ns
t_{DHW}	Write Data Hold Time	100	-	-	ns
t_{CLKL}	Clock Low Time	100	-	-	ns
t_{CLKH}	Clock High Time	100	-	-	ns
t_R	Rise Time	-	-	15	ns
t_F	Fall Time	-	-	15	ns

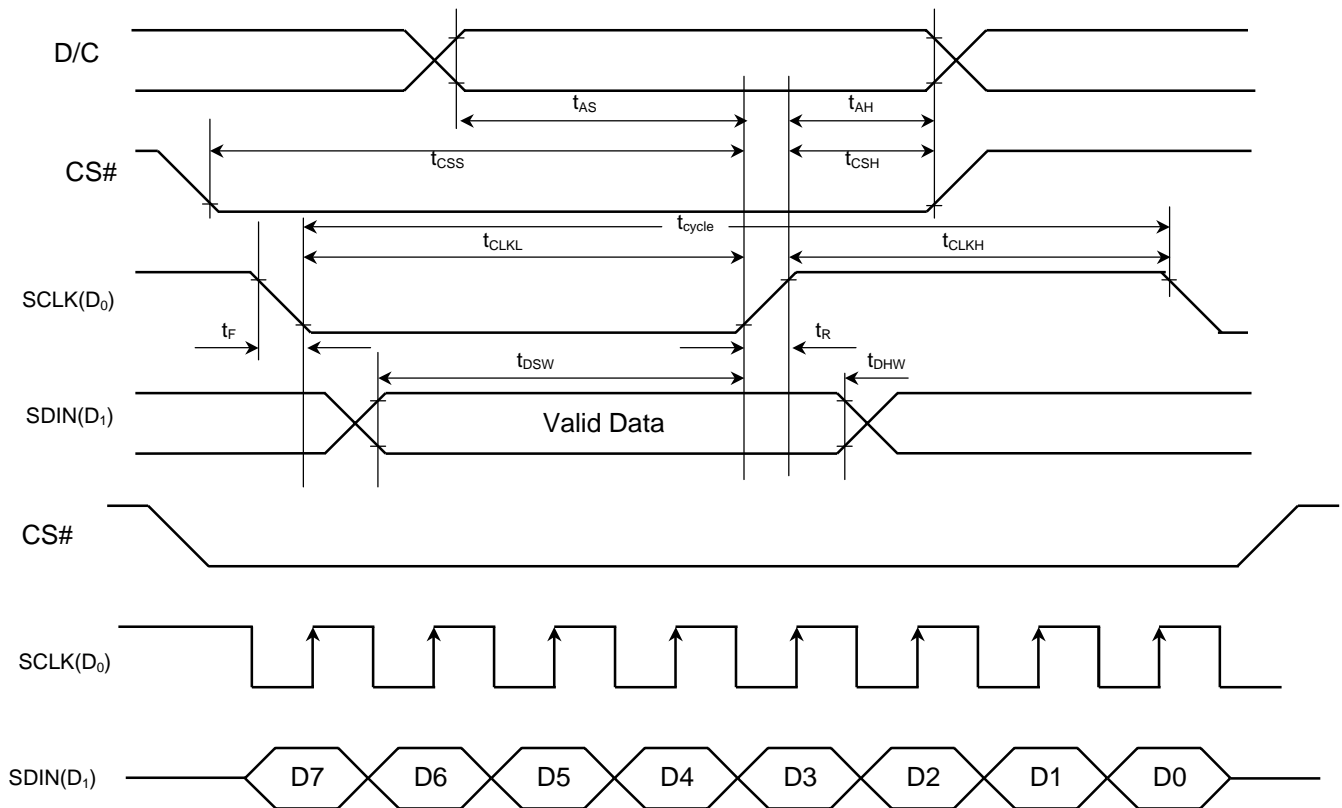
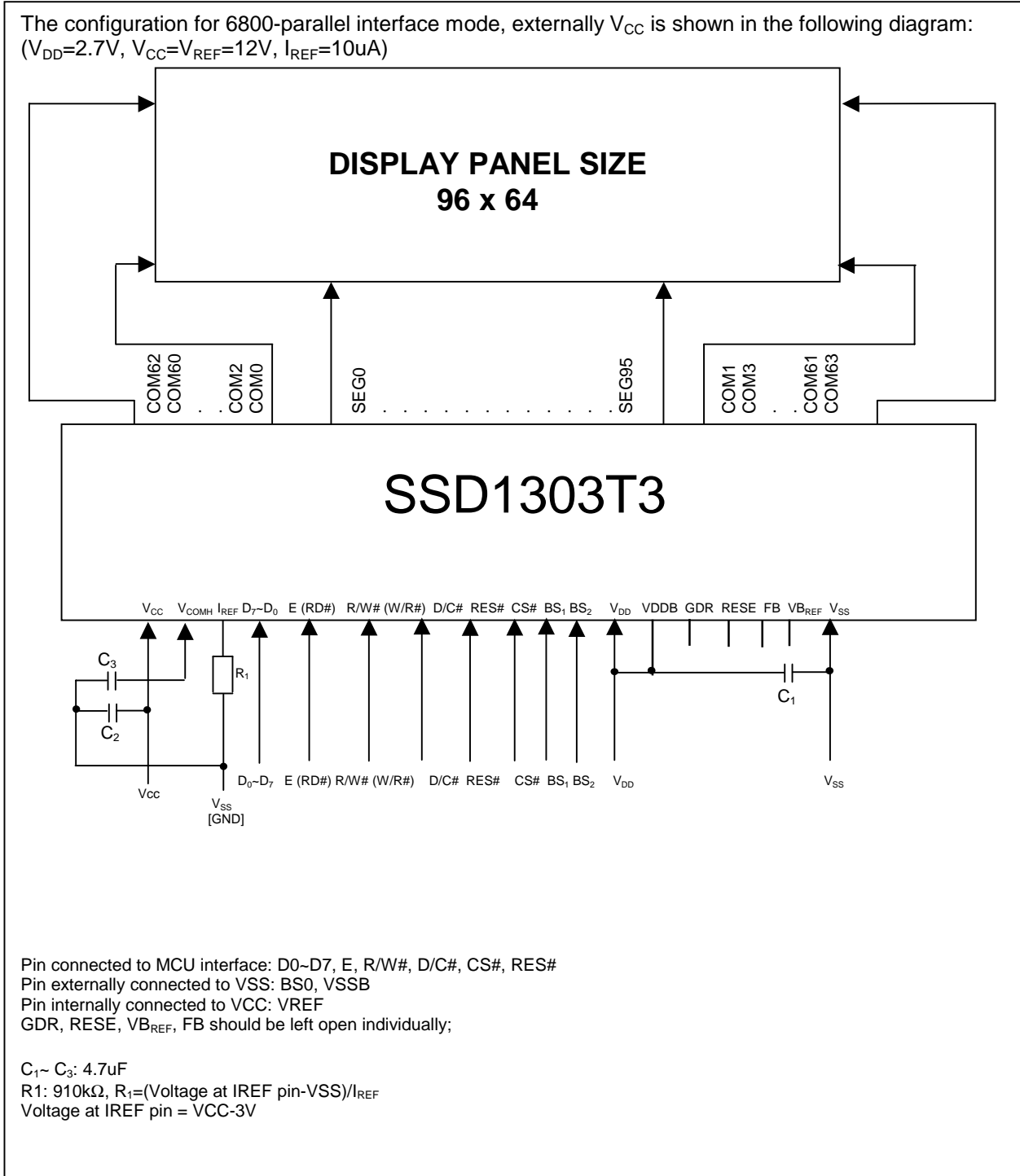

Figure 12 - Serial interface characteristics

13 APPLICATION EXAMPLE

Figure 13 - Application Example (Block Diagram of SSD1303T3)



14 SSD1303T3R1 PACKAGE DETAILS

SSD1303T3R1 Pin Assignment

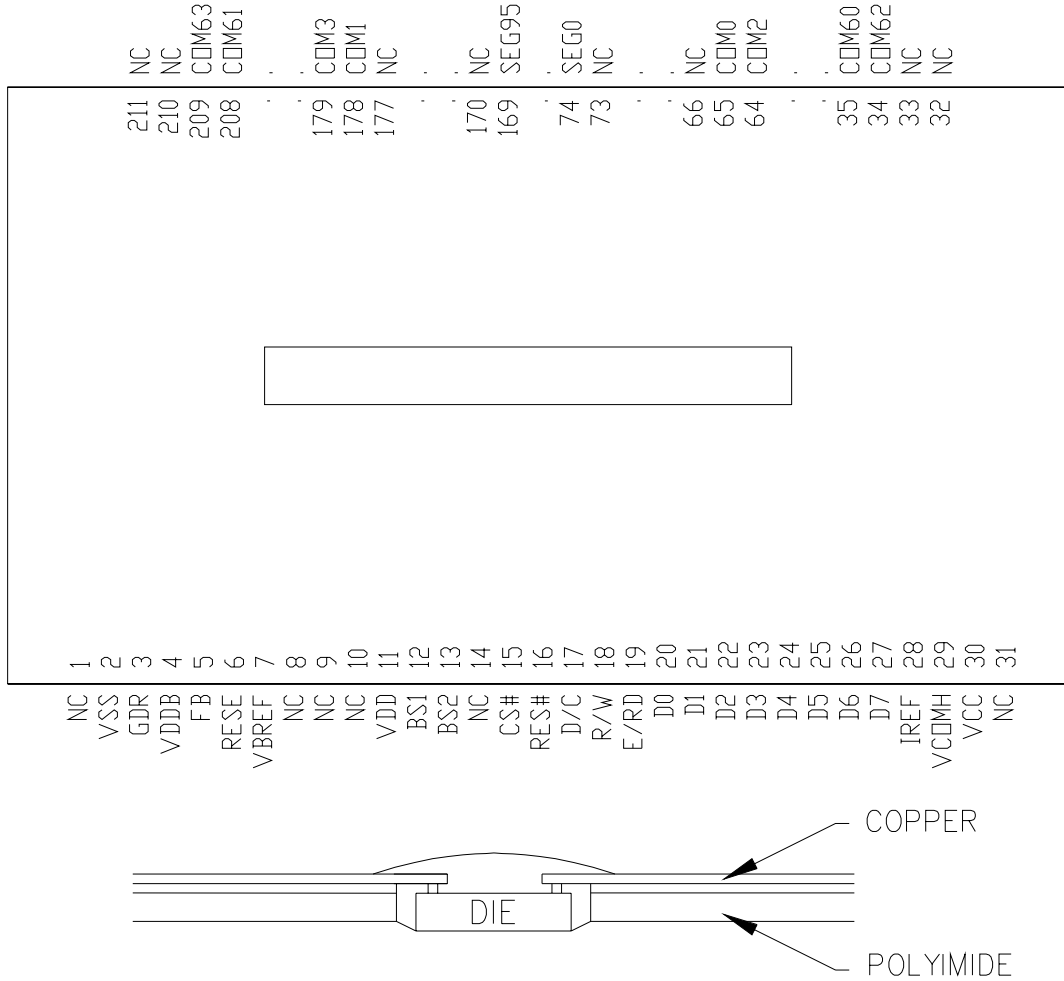

Figure 14 - SSD1303T3R1 pin assignment (Copper view, Normal TAB design)

Remark:

- Use internal clock
- VREF is connected to VCC
- Support MCU interface: 8-bit 6800/8080 parallel interface and SPI
- VSSB, BGGND are connected to VSS
- BS0 is connected to VSS

Table 13 - SSD1303T3R1 pin assignment

Pin no.	Pin name	Pin no.	Pin name	Pin no.	Pin name	Pin no.	Pin name
1	NC	61	COM8	121	SEG47	181	COM7
2	VSS	62	COM6	122	SEG48	182	COM9
3	GDR	63	COM4	123	SEG49	183	COM11
4	VDDDB	64	COM2	124	SEG50	184	COM13
5	FB	65	COM0	125	SEG51	185	COM15
6	RESE	66	NC	126	SEG52	186	COM17
7	VBREF	67	NC	127	SEG53	187	COM19
8	GP0	68	NC	128	SEG54	188	COM21
9	GP1	69	NC	129	SEG55	189	COM23
10	NC	70	NC	130	SEG56	190	COM25
11	VDD1	71	NC	131	SEG57	191	COM27
12	BS1	72	NC	132	SEG58	192	COM29
13	BS2	73	NC	133	SEG59	193	COM31
14	NC	74	SEG0	134	SEG60	194	COM33
15	CS#	75	SEG1	135	SEG61	195	COM35
16	RES#	76	SEG2	136	SEG62	196	COM37
17	D/C	77	SEG3	137	SEG63	197	COM39
18	R/W	78	SEG4	138	SEG64	198	COM41
19	E/RD	79	SEG5	139	SEG65	199	COM43
20	D0	80	SEG6	140	SEG66	200	COM45
21	D1	81	SEG7	141	SEG67	201	COM47
22	D2	82	SEG8	142	SEG68	202	COM49
23	D3	83	SEG9	143	SEG69	203	COM51
24	D4	84	SEG10	144	SEG70	204	COM53
25	D5	85	SEG11	145	SEG71	205	COM55
26	D6	86	SEG12	146	SEG72	206	COM57
27	D7	87	SEG13	147	SEG73	207	COM59
28	IREF	88	SEG14	148	SEG74	208	COM61
29	VCOMH	89	SEG15	149	SEG75	209	COM63
30	VCC	90	SEG16	150	SEG76	210	NC
31	NC	91	SEG17	151	SEG77	211	NC
32	NC	92	SEG18	152	SEG78		
33	NC	93	SEG19	153	SEG79		
34	COM62	94	SEG20	154	SEG80		
35	COM60	95	SEG21	155	SEG81		
36	COM58	96	SEG22	156	SEG82		
37	COM56	97	SEG23	157	SEG83		
38	COM54	98	SEG24	158	SEG84		
39	COM52	99	SEG25	159	SEG85		
40	COM50	100	SEG26	160	SEG86		
41	COM48	101	SEG27	161	SEG87		
42	COM46	102	SEG28	162	SEG88		
43	COM44	103	SEG29	163	SEG89		
44	COM42	104	SEG30	164	SEG90		
45	COM40	105	SEG31	165	SEG91		
46	COM38	106	SEG32	166	SEG92		
47	COM36	107	SEG33	167	SEG93		
48	COM34	108	SEG34	168	SEG94		
49	COM32	109	SEG35	169	SEG95		
50	COM30	110	SEG36	170	NC		
51	COM28	111	SEG37	171	NC		
52	COM26	112	SEG38	172	NC		
53	COM24	113	SEG39	173	NC		
54	COM22	114	SEG40	174	NC		
55	COM20	115	SEG41	175	NC		
56	COM18	116	SEG42	176	NC		
57	COM16	117	SEG43	177	NC		
58	COM14	118	SEG44	178	COM1		
59	COM12	119	SEG45	179	COM3		
60	COM10	120	SEG46	180	COM5		

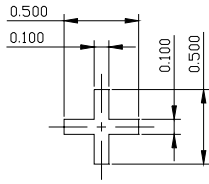

DETAIL A
SCALE 2:1

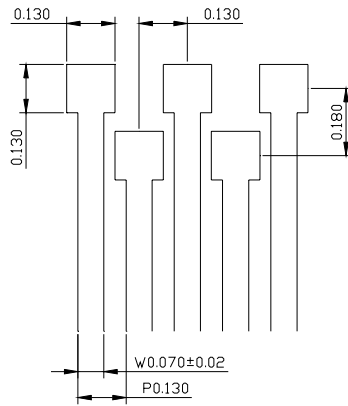

DETAIL B
SCALE 5:1

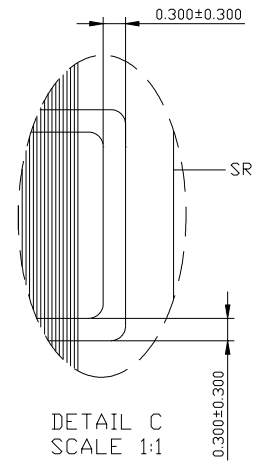

DETAIL C
SCALE 1:1

15 SSD1303T6R1 PACKAGE DETAILS

SSD1303T6R1 Pin Assignment

Figure 15 - SSD1303T6R1 pin assignment (Copper view)

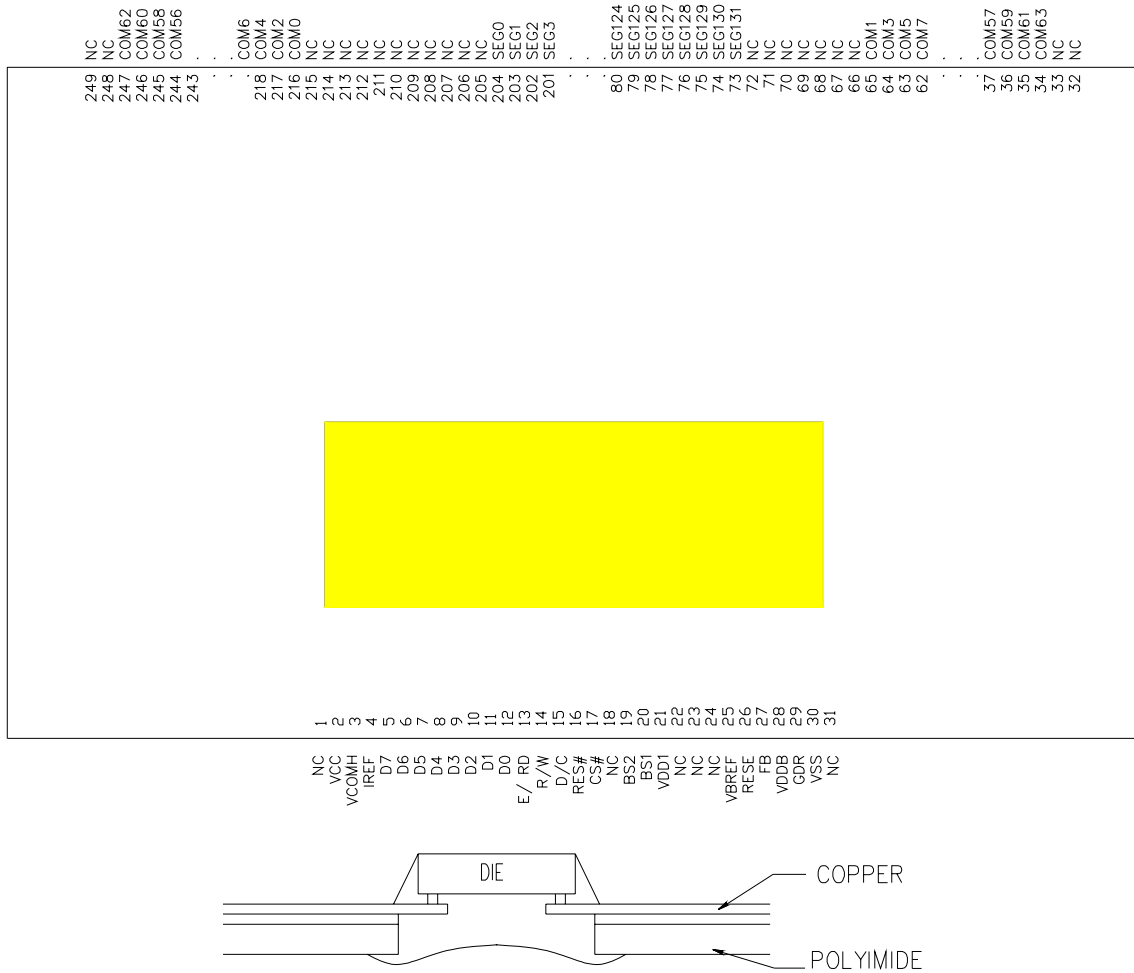

Remark:

- Use internal clock
- VREF is connected to VCC
- Support MCU interface: 8-bit 6800/8080 parallel interface and SPI
- VSSB, BGGND are connected to VSS
- BS0 is connected to VSS

Table 14 - SSD1303T6R1 pin assignment

Pin no.	Pin name	Pin no.	Pin name	Pin no.	Pin name	Pin no.	Pin name	Pin no.	Pin name
1	NC	61	COM9	121	SEG83	181	SEG23	241	COM50
2	VCC	62	COM7	122	SEG82	182	SEG22	242	COM52
3	VCOMH	63	COM5	123	SEG81	183	SEG21	243	COM54
4	IREF	64	COM3	124	SEG80	184	SEG20	244	COM56
5	D7	65	COM1	125	SEG79	185	SEG19	245	COM58
6	D6	66	NC	126	SEG78	186	SEG18	246	COM60
7	D5	67	NC	127	SEG77	187	SEG17	247	COM62
8	D4	68	NC	128	SEG76	188	SEG16	248	NC
9	D3	69	NC	129	SEG75	189	SEG15	249	NC
10	D2	70	NC	130	SEG74	190	SEG14		
11	D1	71	NC	131	SEG73	191	SEG13		
12	D0	72	NC	132	SEG72	192	SEG12		
13	E/RD	73	SEG131	133	SEG71	193	SEG11		
14	R/W	74	SEG130	134	SEG70	194	SEG10		
15	D/C	75	SEG129	135	SEG69	195	SEG9		
16	RES#	76	SEG128	136	SEG68	196	SEG8		
17	CS#	77	SEG127	137	SEG67	197	SEG7		
18	NC	78	SEG126	138	SEG66	198	SEG6		
19	BS2	79	SEG125	139	SEG65	199	SEG5		
20	BS1	80	SEG124	140	SEG64	200	SEG4		
21	VDD	81	SEG123	141	SEG63	201	SEG3		
22	NC	82	SEG122	142	SEG62	202	SEG2		
23	NC	83	SEG121	143	SEG61	203	SEG1		
24	NC	84	SEG120	144	SEG60	204	SEG0		
25	VBREF	85	SEG119	145	SEG59	205	NC		
26	RESE	86	SEG118	146	SEG58	206	NC		
27	FB	87	SEG117	147	SEG57	207	NC		
28	VDDDB	88	SEG116	148	SEG56	208	NC		
29	GDR	89	SEG115	149	SEG55	209	NC		
30	VSS	90	SEG114	150	SEG54	210	NC		
31	NC	91	SEG113	151	SEG53	211	NC		
32	NC	92	SEG112	152	SEG52	212	NC		
33	NC	93	SEG111	153	SEG51	213	NC		
34	COM63	94	SEG110	154	SEG50	214	NC		
35	COM61	95	SEG109	155	SEG49	215	NC		
36	COM59	96	SEG108	156	SEG48	216	COM0		
37	COM57	97	SEG107	157	SEG47	217	COM2		
38	COM55	98	SEG106	158	SEG46	218	COM4		
39	COM53	99	SEG105	159	SEG45	219	COM6		
40	COM51	100	SEG104	160	SEG44	220	COM8		
41	COM49	101	SEG103	161	SEG43	221	COM10		
42	COM47	102	SEG102	162	SEG42	222	COM12		
43	COM45	103	SEG101	163	SEG41	223	COM14		
44	COM43	104	SEG100	164	SEG40	224	COM16		
45	COM41	105	SEG99	165	SEG39	225	COM18		
46	COM39	106	SEG98	166	SEG38	226	COM20		
47	COM37	107	SEG97	167	SEG37	227	COM22		
48	COM35	108	SEG96	168	SEG36	228	COM24		
49	COM33	109	SEG95	169	SEG35	229	COM26		
50	COM31	110	SEG94	170	SEG34	230	COM28		
51	COM29	111	SEG93	171	SEG33	231	COM30		
52	COM27	112	SEG92	172	SEG32	232	COM32		
53	COM25	113	SEG91	173	SEG31	233	COM34		
54	COM23	114	SEG90	174	SEG30	234	COM36		
55	COM21	115	SEG89	175	SEG29	235	COM38		
56	COM19	116	SEG88	176	SEG28	236	COM40		
57	COM17	117	SEG87	177	SEG27	237	COM42		
58	COM15	118	SEG86	178	SEG26	238	COM44		
59	COM13	119	SEG85	179	SEG25	239	COM46		
60	COM11	120	SEG84	180	SEG24	240	COM48		

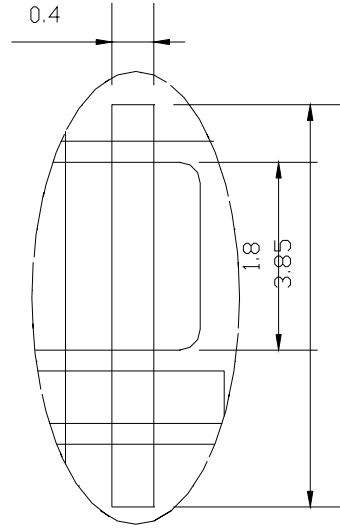
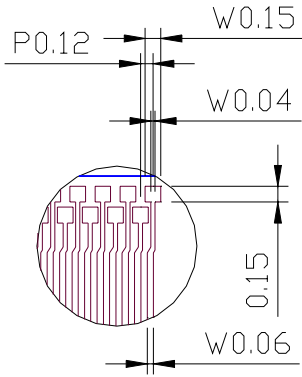

DETAIL C

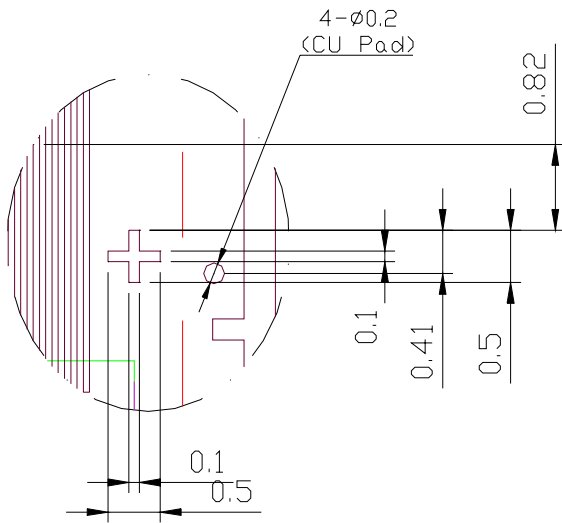

DETAIL B

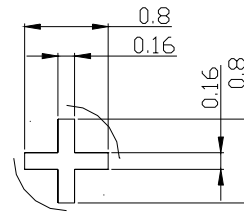

DETAIL D

1	NC	170	NC	211	NC
2	VSS	169	SEG95	210	NC
3	GDR	179	CDM3	209	CDM63
4	VDDDB	178	CDM1	208	CDM61
5	FB	177	NC		
6	RESE				
7	VBREF				
8	NC				
9	NC				
10	NC				
11	VDD				
12	BS1				
13	BS2				
14	NC				
15	CS#				
16	RES#				
17	D/C	74	SEG0		
18	R/W	73	NC		
19	E/RD				
20	D0				
21	D1			66	NC
22	D2			65	CDM0
23	D3			64	CDM2
24	D4				
25	D5				
26	D6				
27	D7				
28	IREF			35	CDM60
29	VCOMH			34	CDM62
30	VCC			33	NC
31	NC			32	NC

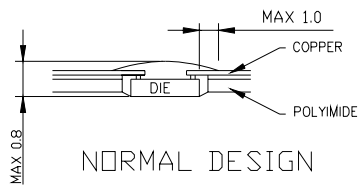

Remark:

- Use internal clock
- VREF is connected to VCC
- Support MCU interface: 8-bit 6800/8080 parallel interface and SPI
- VSSB, BGGND are connected to VSS
- BS0 is connected to VSS

Table 15 - SSD1303T8R1 pin assignment

Pin no.	Pin name	Pin no.	Pin name	Pin no.	Pin name	Pin no.	Pin name
1	NC	61	COM8	121	SEG47	181	COM7
2	VSS	62	COM6	122	SEG48	182	COM9
3	GDR	63	COM4	123	SEG49	183	COM11
4	VDDB	64	COM2	124	SEG50	184	COM13
5	FB	65	COM0	125	SEG51	185	COM15
6	RESE	66	NC	126	SEG52	186	COM17
7	VBREF	67	NC	127	SEG53	187	COM19
8	GP0	68	NC	128	SEG54	188	COM21
9	GP1	69	NC	129	SEG55	189	COM23
10	NC	70	NC	130	SEG56	190	COM25
11	VDD1	71	NC	131	SEG57	191	COM27
12	BS1	72	NC	132	SEG58	192	COM29
13	BS2	73	NC	133	SEG59	193	COM31
14	NC	74	SEG0	134	SEG60	194	COM33
15	CS#	75	SEG1	135	SEG61	195	COM35
16	RES#	76	SEG2	136	SEG62	196	COM37
17	D/C	77	SEG3	137	SEG63	197	COM39
18	R/W	78	SEG4	138	SEG64	198	COM41
19	E/RD	79	SEG5	139	SEG65	199	COM43
20	D0	80	SEG6	140	SEG66	200	COM45
21	D1	81	SEG7	141	SEG67	201	COM47
22	D2	82	SEG8	142	SEG68	202	COM49
23	D3	83	SEG9	143	SEG69	203	COM51
24	D4	84	SEG10	144	SEG70	204	COM53
25	D5	85	SEG11	145	SEG71	205	COM55
26	D6	86	SEG12	146	SEG72	206	COM57
27	D7	87	SEG13	147	SEG73	207	COM59
28	IREF	88	SEG14	148	SEG74	208	COM61
29	VCOMH	89	SEG15	149	SEG75	209	COM63
30	VCC	90	SEG16	150	SEG76	210	NC
31	NC	91	SEG17	151	SEG77	211	NC
32	NC	92	SEG18	152	SEG78		
33	NC	93	SEG19	153	SEG79		
34	COM62	94	SEG20	154	SEG80		
35	COM60	95	SEG21	155	SEG81		
36	COM58	96	SEG22	156	SEG82		
37	COM56	97	SEG23	157	SEG83		
38	COM54	98	SEG24	158	SEG84		
39	COM52	99	SEG25	159	SEG85		
40	COM50	100	SEG26	160	SEG86		
41	COM48	101	SEG27	161	SEG87		
42	COM46	102	SEG28	162	SEG88		
43	COM44	103	SEG29	163	SEG89		
44	COM42	104	SEG30	164	SEG90		
45	COM40	105	SEG31	165	SEG91		
46	COM38	106	SEG32	166	SEG92		
47	COM36	107	SEG33	167	SEG93		
48	COM34	108	SEG34	168	SEG94		
49	COM32	109	SEG35	169	SEG95		
50	COM30	110	SEG36	170	NC		
51	COM28	111	SEG37	171	NC		
52	COM26	112	SEG38	172	NC		
53	COM24	113	SEG39	173	NC		
54	COM22	114	SEG40	174	NC		
55	COM20	115	SEG41	175	NC		
56	COM18	116	SEG42	176	NC		
57	COM16	117	SEG43	177	NC		
58	COM14	118	SEG44	178	COM1		
59	COM12	119	SEG45	179	COM3		
60	COM10	120	SEG46	180	COM5		

SSD1303T8R1 TAB Package Dimensions

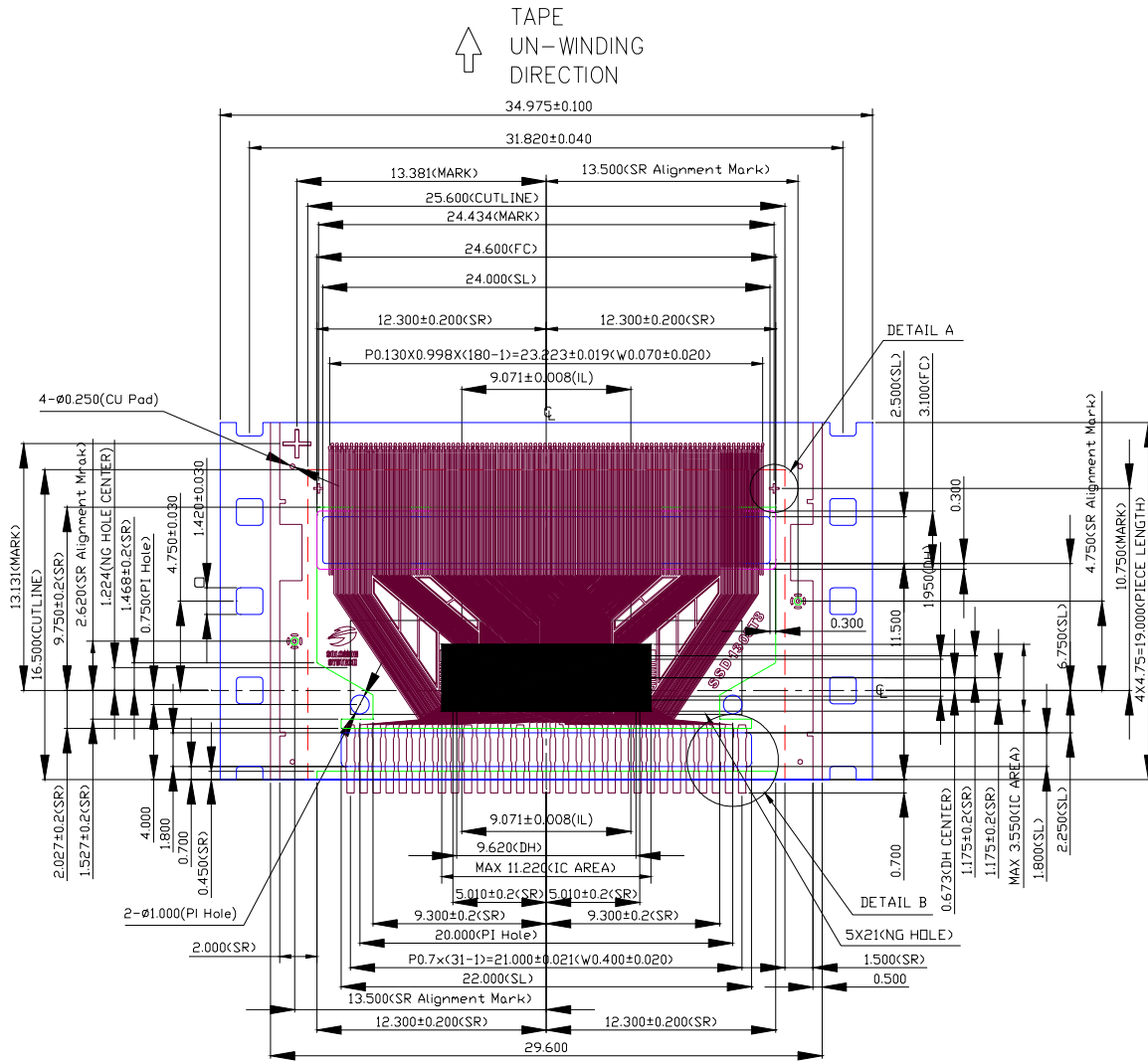

- NOTE:
- GENERAL TOLERANCE: ±0.05MM
 - MATERIAL
 PI: 75±6um
 ADHESIVE: 12±2um
 CU: 18±5um
 SR: 26±14um
 TOLERANCE±0.200
 FLEX COATING: Min10um
 - SN PLATING: 0.200±0.05um
 - TAPESITE: 4 SPH,19mm

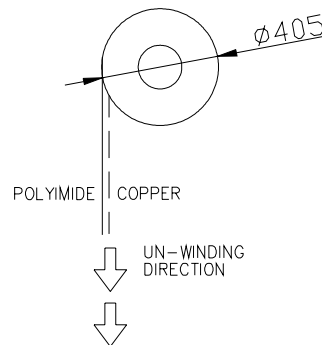

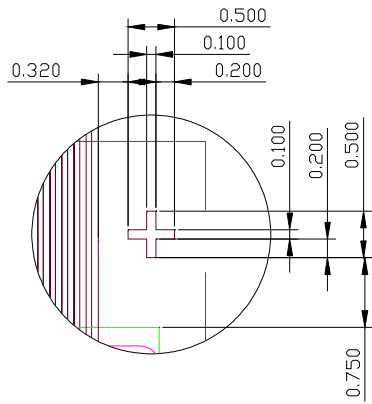

DETAIL A

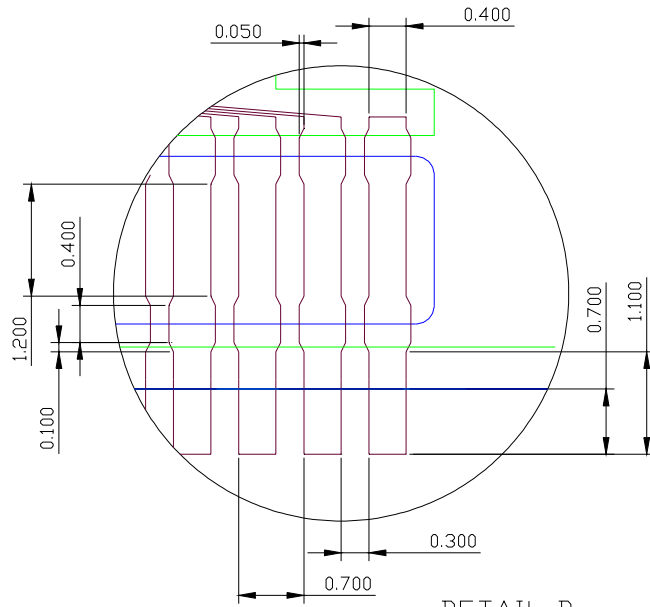

DETAIL B

17 SSD1303T9R1 PACKAGE DETAILS

SSD1303T9R1 Pin Assignment

Figure 16 - SSD1303T9R1 pin assignment (Copper view)

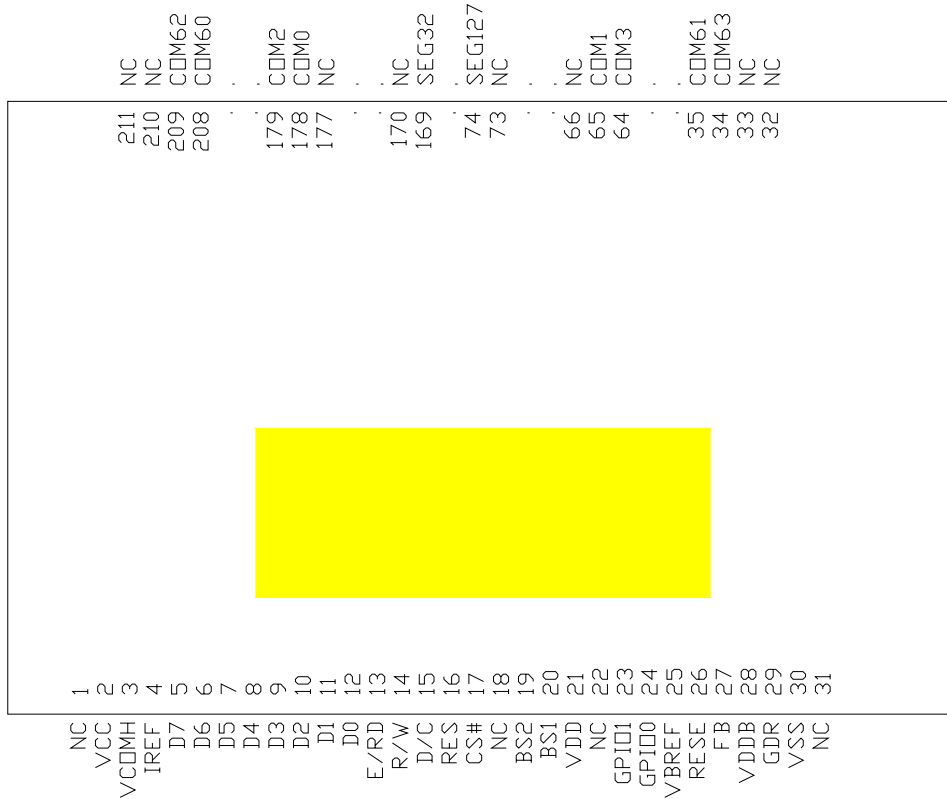

Remark:

- Use internal clock
- VREF is connected to VCC
- Support MCU interface: 8-bit 6800/8080 parallel interface and SPI
- VSSB, BGGND are connected to VSS
- BS0 is connected to VSS

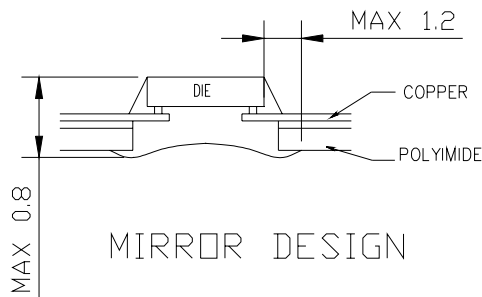
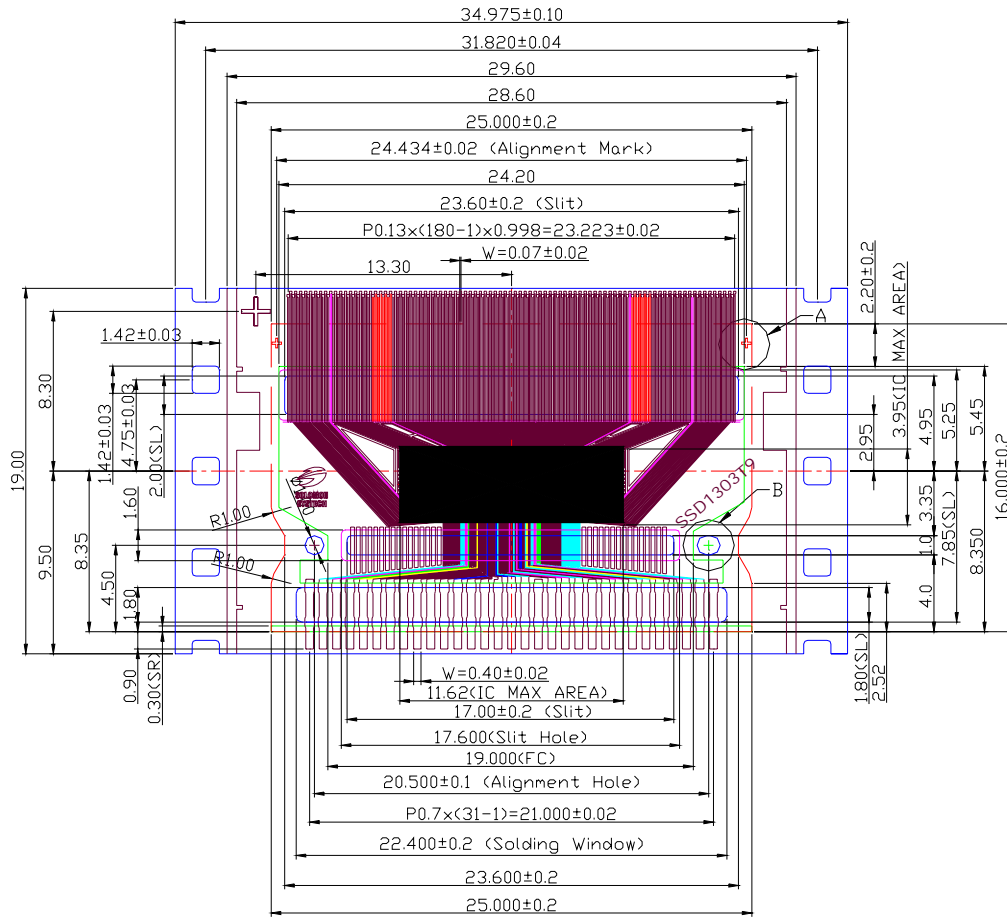

Table 16 - SSD1303T9R1 pin assignment

Pin No.	Pin name	Pin No.	Pin name	Pin No.	Pin name	Pin No.	Pin name
1	NC	61	COM9	121	SEG80	181	COM6
2	VCC	62	COM7	122	SEG79	182	COM8
3	VCOMH	63	COM5	123	SEG78	183	COM10
4	IREF	64	COM3	124	SEG77	184	COM12
5	D7	65	COM1	125	SEG76	185	COM14
6	D6	66	NC	126	SEG75	186	COM16
7	D5	67	NC	127	SEG74	187	COM18
8	D4	68	NC	128	SEG73	188	COM20
9	D3	69	NC	129	SEG72	189	COM22
10	D2	70	NC	130	SEG71	190	COM24
11	D1	71	NC	131	SEG70	191	COM26
12	D0	72	NC	132	SEG69	192	COM28
13	E	73	NC	133	SEG68	193	COM30
14	R/W	74	SEG127	134	SEG67	194	COM32
15	D/C	75	SEG126	135	SEG66	195	COM34
16	RES	76	SEG125	136	SEG65	196	COM36
17	CS#	77	SEG124	137	SEG64	197	COM38
18	NC	78	SEG123	138	SEG63	198	COM40
19	BS2	79	SEG122	139	SEG62	199	COM42
20	BS1	80	SEG121	140	SEG61	200	COM44
21	VDD1	81	SEG120	141	SEG60	201	COM46
22	NC	82	SEG119	142	SEG59	202	COM48
23	GPIO1	83	SEG118	143	SEG58	203	COM50
24	GPIO0	84	SEG117	144	SEG57	204	COM52
25	VBREF	85	SEG116	145	SEG56	205	COM54
26	RESE	86	SEG115	146	SEG55	206	COM56
27	FB	87	SEG114	147	SEG54	207	COM58
28	VDDB	88	SEG113	148	SEG53	208	COM60
29	GDR	89	SEG112	149	SEG52	209	COM62
30	VSS	90	SEG111	150	SEG51	210	NC
31	NC	91	SEG110	151	SEG50	211	NC
32	NC	92	SEG109	152	SEG49		
33	NC	93	SEG108	153	SEG48		
34	COM63	94	SEG107	154	SEG47		
35	COM61	95	SEG106	155	SEG46		
36	COM59	96	SEG105	156	SEG45		
37	COM57	97	SEG104	157	SEG44		
38	COM55	98	SEG103	158	SEG43		
39	COM53	99	SEG102	159	SEG42		
40	COM51	100	SEG101	160	SEG41		
41	COM49	101	SEG100	161	SEG40		
42	COM47	102	SEG99	162	SEG39		
43	COM45	103	SEG98	163	SEG38		
44	COM43	104	SEG97	164	SEG37		
45	COM41	105	SEG96	165	SEG36		
46	COM39	106	SEG95	166	SEG35		
47	COM37	107	SEG94	167	SEG34		
48	COM35	108	SEG93	168	SEG33		
49	COM33	109	SEG92	169	SEG32		
50	COM31	110	SEG91	170	NC		
51	COM29	111	SEG90	171	NC		
52	COM27	112	SEG89	172	NC		
53	COM25	113	SEG88	173	NC		
54	COM23	114	SEG87	174	NC		
55	COM21	115	SEG86	175	NC		
56	COM19	116	SEG85	176	NC		
57	COM17	117	SEG84	177	NC		
58	COM15	118	SEG83	178	COM0		
59	COM13	119	SEG82	179	COM2		
60	COM11	120	SEG81	180	COM4		

SSD1303T9R1 TAB Package Dimensions



 TAPE
 UN-WINDING
 DIRECTION

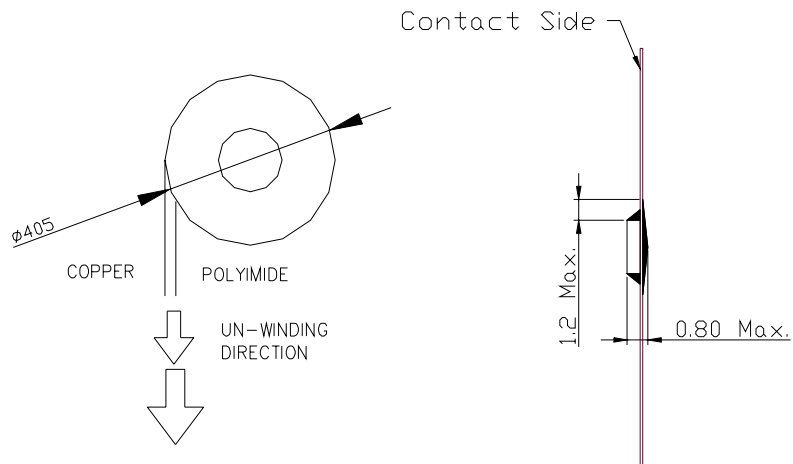

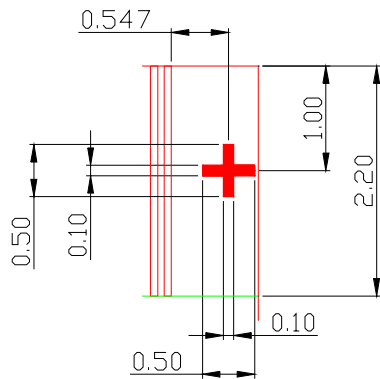

NOTE:

1. GENERAL TOLERANCE: $\pm 0.05\text{MM}$
2. MATERIAL
 PI: $75\pm 6\mu\text{m}$
 ADHESIVE: $12\pm 2\mu\text{m}$
 CU: $18\pm 5\mu\text{m}$
 SR: $26\pm 14\mu\text{m}$
 TOLERANCE ± 0.150
 FLEX COATING: FS-100L Min $10\mu\text{m}$
3. SN PLATING: $0.200\pm 0.05\mu\text{m}$
4. TAPESITE: 4 SPH, 19mm



Detail A
Scale: 4x

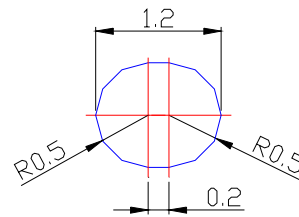

Detail B
Scale: 4x

18 SSD1303Z PACKAGE DETAILS

DIE TRAY DIMENSIONS

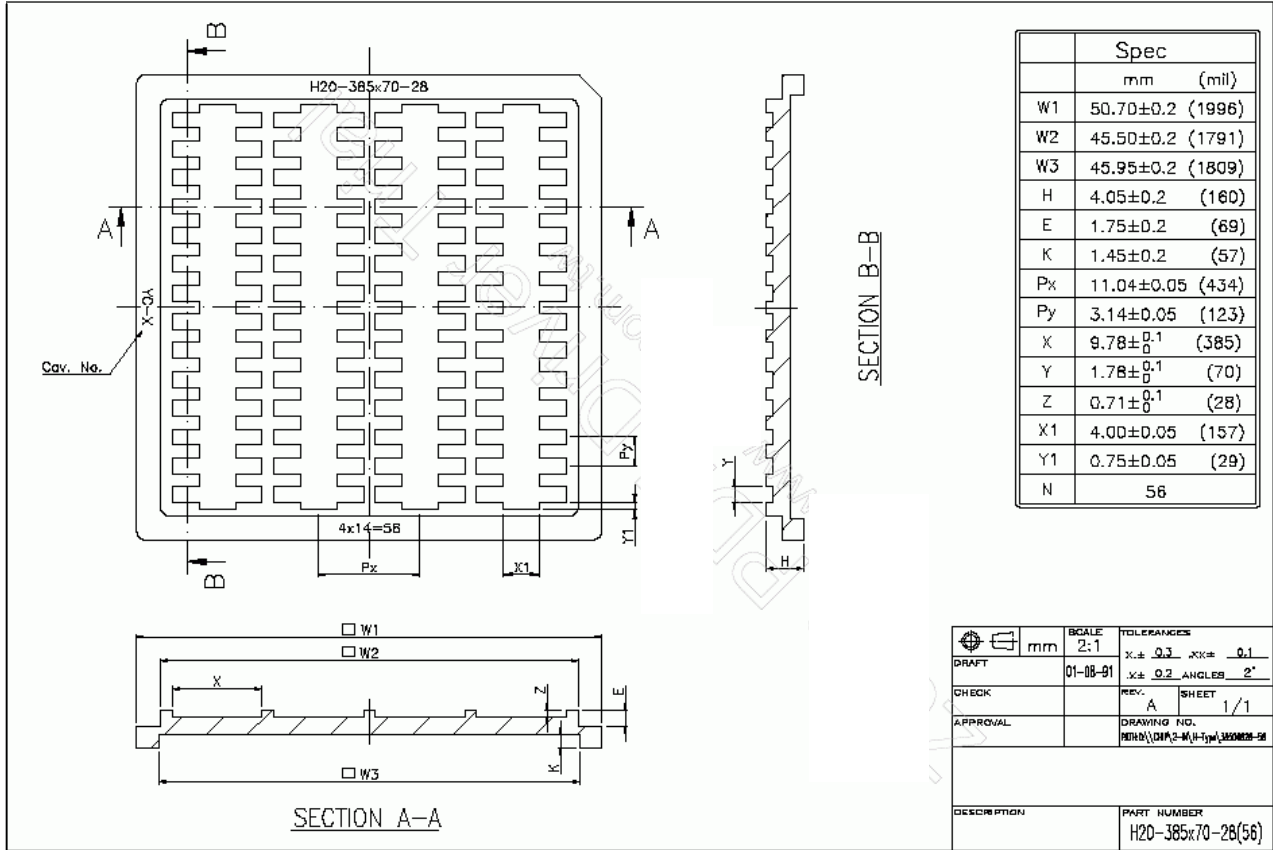

Solomon Systech reserves the right to make changes without further notice to any products herein. Solomon Systech makes no warranty, representation or guarantee regarding the suitability of its products for any particular purpose, nor does Solomon Systech assume any liability arising out of the application or use of any product or circuit, and specifically disclaims any and all liability, including without limitation consequential or incidental damages. "Typical" parameters can and do vary in different applications. All operating parameters, including "Typicals" must be validated for each customer application by customer's technical experts. Solomon Systech does not convey any license under its patent rights nor the rights of others. Solomon Systech products are not designed, intended, or authorized for use as components in systems intended for surgical implant into the body, or other applications intended to support or sustain life, or for any other application in which the failure of the Solomon Systech product could create a situation where personal injury or death may occur. Should Buyer purchase or use Solomon Systech products for any such unintended or unauthorized application, Buyer shall indemnify and hold Solomon Systech and its offices, employees, subsidiaries, affiliates, and distributors harmless against all claims, costs, damages, and expenses, and reasonable attorney fees arising out of, directly or indirectly, any claim of personal injury or death associated with such unintended or unauthorized use, even if such claim alleges that Solomon Systech was negligent regarding the design or manufacture of the part.

<http://www.solomon-systech.com>



Crystalfontz America, Incorporated

CFA10009 Demonstration Board Kits User Guide

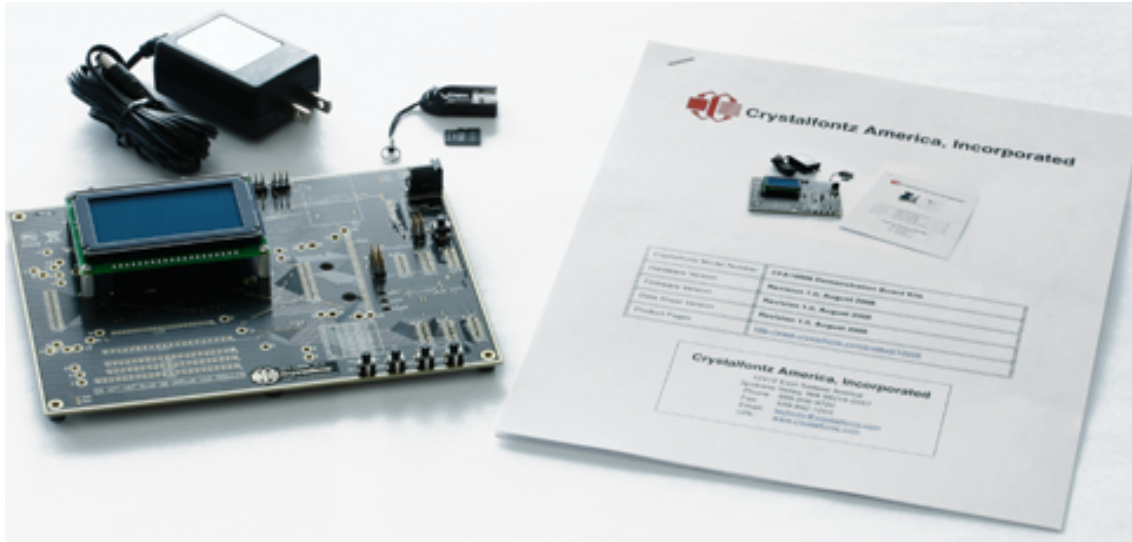

Crystalfontz Model Number	CFA10009 Demonstration Board Kits (for OLEDs)
Hardware Version	Revision 1.1, June 2009
Firmware Version	Revision 1.0, June 2009
Data Sheet Version	Revision 1.0, June 2009
Product Pages	www.crystalfontz.com/product/CFA10009.html

Crystalfontz America, Incorporated

12412 East Saltese Avenue
Spokane Valley, WA 99216-0357
Phone: 888-206-9720
Fax: 509-892-1203
Email: techinfo@crystalfontz.com
URL: www.crystalfontz.com



REVISION HISTORY

CFA10009 DEMONSTATION BOARD	
2009/06/25	Current demonstration board version: v1.1 New demonstration board.

CFA10009 DEMONSTRATION BOARD KITS FIRMWARE	
2009/06/25	Current firmware version (series): v1.0 Initial release.

CFA10009 DEMONSTRATION BOARD KITS USER GUIDE	
2009/06/25	Current Data Sheet version: v1.0 New Data Sheet.

The Fine Print

Certain applications using CrystalFontz America, Inc. products may involve potential risks of death, personal injury, or severe property or environmental damage ("Critical Applications"). CRYSTALFONTZ AMERICA, INC. PRODUCTS ARE NOT DESIGNED, INTENDED, AUTHORIZED, OR WARRANTED TO BE SUITABLE FOR USE IN LIFE-SUPPORT APPLICATIONS, DEVICES OR SYSTEMS OR OTHER CRITICAL APPLICATIONS. Inclusion of CrystalFontz America, Inc. products in such applications is understood to be fully at the risk of the customer. In order to minimize risks associated with customer applications, adequate design and operating safeguards should be provided by the customer to minimize inherent or procedural hazard. Please contact us if you have any questions concerning potential risk applications.

CrystalFontz America, Inc. assumes no liability for applications assistance, customer product design, software performance, or infringements of patents or services described herein. Nor does CrystalFontz America, Inc. warrant or represent that any license, either express or implied, is granted under any patent right, copyright, or other intellectual property right of CrystalFontz America, Inc. covering or relating to any combination, machine, or process in which our products or services might be or are used.

The information in this publication is deemed accurate but is not guaranteed.

Company and product names mentioned in this publication are trademarks or registered trademarks of their respective owners.

Copyright © 2009 by CrystalFontz America, Inc., 12412 East Saltese Avenue, Spokane Valley, WA 99216-0357 U.S.A.



QUICK START

The CFA10009 demonstration board is shipped with a compatible OLED module of your choice installed and tested. Simply plug the power supply (included) into an AC outlet. The CFA10009 will initialize and turn on the display, then run the demonstration script from the included microSD card.

INTRODUCTION

The CFA10009 Demonstration Board Kit has everything you need to easily demonstrate and experiment with one compatible CrystalFontz OLED module. The kit can also be used as a reference for your designs that use a CrystalFontz OLED module listed in the table on the next page.

You can easily modify the miniBASIC scripts and bitmaps on the microSD card to make your own test screens, or even to model user interface functions. All that is needed is the included microSD USB reader, a [text editor](#) (Notepad will do), an [image editor](#) (MS Paint will do), and a simple, open-source format conversion utility ([Image2Code](#)) that we offer free of charge.

Beyond demonstrations, the CFA10009 allows you to easily measure current of the different portions of the circuit under operation.

The schematic, bill of materials, and even the PCB layout is available for download from our site. (As always, no registration is required.) Since the design materials are available before purchase, there is no risk of being "surprised" late in the design.

The CFA10009 is preprogrammed with a microSD boot loader. You can load our simple C example code, the miniBASIC interpreter, or build your own application for the CFA10009's versatile Atmel [ATMEGA2561](#) microcontroller using [AVR Studio](#) and [WinAVR](#) (both free).

The board has a JTAG port for more advanced programming and debugging. All the ports are on 0.1" centers so you can connect them to anything you need. The CFA10009 is so versatile that you may want to use it as a base development platform for your projects.



CFA10009 KIT CONFIGURATIONS

FOR OLED MODULE	WITH THIS CONTROLLER	ORDER THIS DEMONSTRATION BOARD KIT	BLOCK DIAGRAM
CFAL12822A-Y-B	Solomon SSD1305	DMO-L12822AYB	Figure 2.
CFAL12822A-Y-B1	Solomon SSD1305	DMO-L12822AYB1	Figure 1.
CFAL12832C-W-B1	Sino Wealth SH1101A	DMO-L12832CWB1	Figure 1.
CFAL12864C-Y-B1	Solomon SSD1305	DMO-L12864CYB1	Figure 1.
CFAL12864L-G-B2	Solomon SSD1305	DMO-L12864LGB2	Figure 2.
CFAL12864L-Y-B2	Solomon SSD1305	DMO-L12864LYB2	Figure 2.
CFAL12864L-G-B2TS	Solomon SSD1305	DMO-L12864LGB2TS	Figure 4.
CFAL12864L-Y-B2TS	Solomon SSD1305	DMO-L12864LYB2TS	Figure 4.
CFAL12864L-G-B4	Solomon SSD1305	DMO-L12864LGB4	Figure 2.
CFAL12864L-Y-B4	Solomon SSD1305	DMO-L12864LYB4	Figure 2.
CFAL12864L-G-B6	Solomon SSD1305	DMO-L12864LGB6	Figure 2.
CFAL12864L-G- B6TS	Solomon SSD1305	DMO-L12864LGB6TS	Figure 3.
CFAL12864L-Y- B6TS	Solomon SSD1305	DMO-L12864LYB6TS	Figure 3.
CFAL12864L-W- B6TS	Solomon SSD1305	DMO-L12864LWB6TS	Figure 3.
CFAL12864N-A-B1	Sino Wealth SH1101A	DMO-L12864NAB1	Figure 1.
CFAL12864S-Y-B1	Solomon SSD1303	DMO-L12864SYB1	Figure 1.
CFAL12864U-W-B1	Solomon SSD1303	DMO-L12864UWB1	Figure 1.
CFAL12864Z-G-B2	Solomon SSD1325	DMO-L12864ZGB2	Figure 2.
CFAL12864Z-Y-B2	Solomon SSD1325	DMO-L12864ZYB2	Figure 2.
CFAL12864Z-G-B2TS	Solomon SSD1325	DMO-L12864ZGB2TS	Figure 4.
CFAL12864Z-Y-B2TS	Solomon SSD1325	DMO-L12864YB2TS	Figure 4.
CFAL12864Z-G-B4	Solomon SSD1325	DMO-L12864ZGB4	Figure 2.
CFAL12864Z-Y-B4	Solomon SSD1325	DMO-L12864ZYB4	Figure 2.
CFAL12864Z-G-B6	Solomon SSD1325	DMO-L12864ZGB6	Figure 2.
CFAL12864Z-W-B6	Solomon SSD1325	DMO-L12864ZWB6	Figure 2.
CFAL12864Z-Y-B6	Solomon SSD1325	DMO-L12864ZYB6	Figure 2.



FOR OLED MODULE	WITH THIS CONTROLLER	ORDER THIS DEMONSTRATION BOARD KIT	BLOCK DIAGRAM
CFAL12864Z-G-B6TS	Solomon SSD1325	DMO-L12864ZGB6TS	Figure 3.
CFAL12864Z-W-B6TS	Solomon SSD1325	DMO-L12864ZWB6TS	Figure 3.
CFAL12864Z-Y-B6TS	Solomon SSD1325	DMO-L12864ZYB6TS	Figure 3.
CFAL25664A-Y-B1	ST STV8105	DMO-L25664AYB1	Figure 1.
CFAL9664A-W-B1	Solomon SSD1305	DMO-L9664AWB1	Figure 1.

CONTENTS OF DEMONSTRATION BOARD KIT

- CFA10009 Demonstration Board (PCB).
- Installed OLED module of your choice. (Selected at time of ordering. See choices in the table above.)
- Power adapter.
- MicroSD memory card loaded with BASIC demonstration program and bitmap images.
- USB reader for the microSD memory card.

In addition to the kit contents, a zipped folder of hardware design and program files is available at <http://www.crystalfontz.com/product/CFA10009.html>. (Free download.)

HOW TO MAKE A CUSTOM DEMONSTRATION

The CFA10009 is programmed with firmware that will read a BASIC program file from the microSD memory card. The BASIC program can read bitmap image files from the microSD memory card and display them on the OLED module. The BASIC program can also read the four demonstration board buttons and change the brightness settings.

By using the USB reader, a text editor, and a graphic conversion utility (provided), you can customize the demonstration to include your own bitmap images. The large capacity of the microSD card allows you to create complex demonstrations.

For the most recent version of the graphic conversion utility, sample scripts, and sample images for customizing the demonstration, download the zipped folder at <http://www.crystalfontz.com/product/CFA10009.html>.

LOADING A CUSTOM HEX FILE

The CFA10009 Demonstration Board Kit is shipped with the miniBasic-AVR interpreter loaded into the microcontroller Atmel ATMEGA2561's flash memory.

If you want to load our simple demonstration or your own program, simply name the hex file "cfa10009.hex" and copy it into the root of the directory of the microSD card. When the CFA10009 boots, the boot loader will program the ATMEGA2561's flash with "cfa10009.hex" and then execute it.



Acknowledgement Note: The miniBASIC-AVR is a derivative of [this](http://www.personal.leeds.ac.uk/~bgy1mm/Minibasic/MiniBasicHome.html) (see <http://www.personal.leeds.ac.uk/~bgy1mm/Minibasic/MiniBasicHome.html>). The miniBASIC-AVR also includes the [EFSL embedded filesystems library](http://efsl.be/) (see <http://efsl.be/>).

HARDWARE DESIGN INFORMATION

BLOCK DIAGRAM

Here are block diagrams of the CFA10009 Demonstration Board with different types of installed modules:

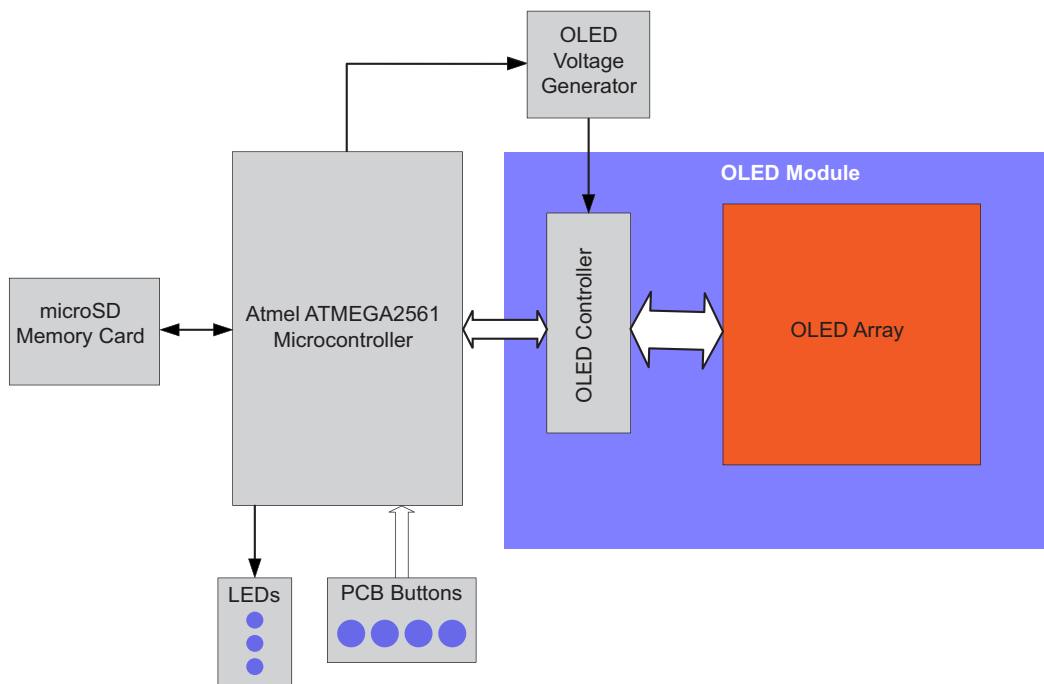

Figure 1. For kits with CFAL12822A-Y-B1, CFAL12832C-W-B1, CFAL12864C-Y-B1, CFAL12864N-A-B1, CFAL12864S-Y-B1, CFAL25664A-Y-B1, and CFAL9664A-W-B1

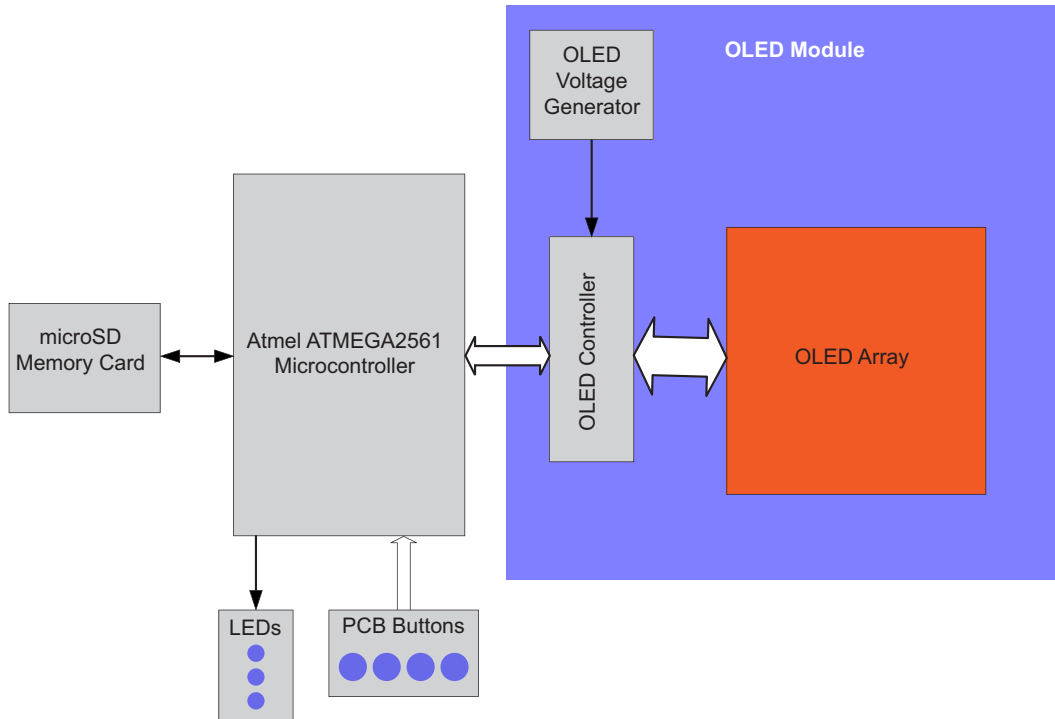

Figure 2. For kits with CFAL12822A-Y-B, CFAL12864L-G-B2, CFAL12864L-Y-B2, CFAL12864L-G-B4,CFAL12864L-Y-B4, CFAL12864L-G-B6, CFAL12864Z-G-B2, CFAL12864Z-Y-B2, CFAL12864Z-G-B4, CFAL12864Z-Y-B4, CFAL12864Z-G-B6,CFAL12864Z-W-B6, and CFAL12864Z-Y-B6

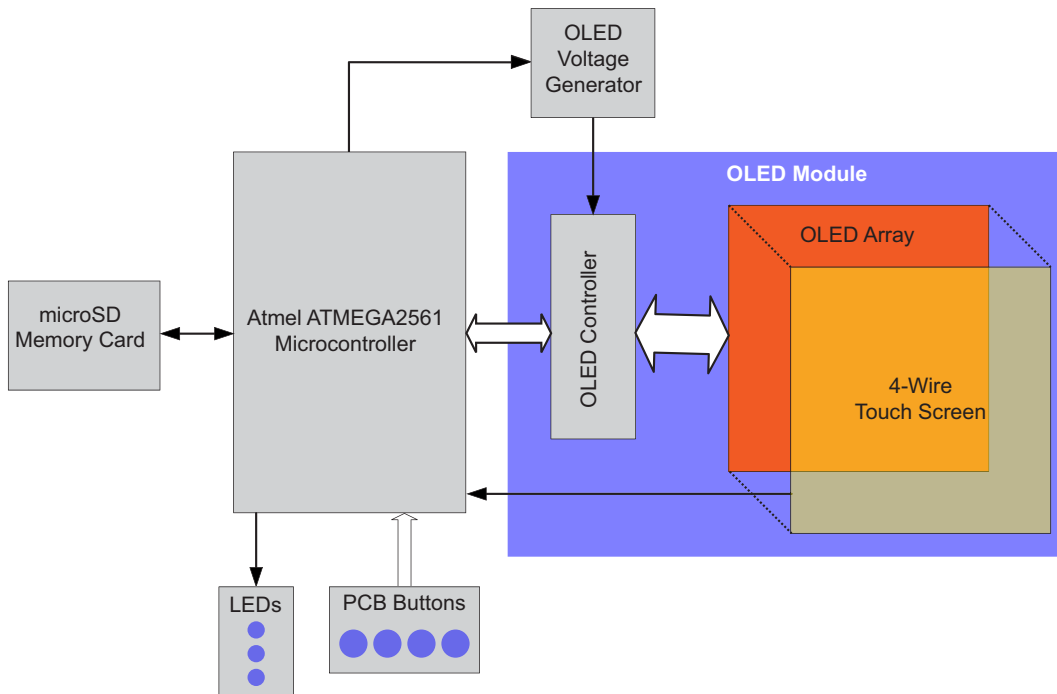

Figure 3. For kits with CFAL12864L-G- B6TS, CFAL12864L-Y- B6TS, and CFAL12864L-W- B6TS

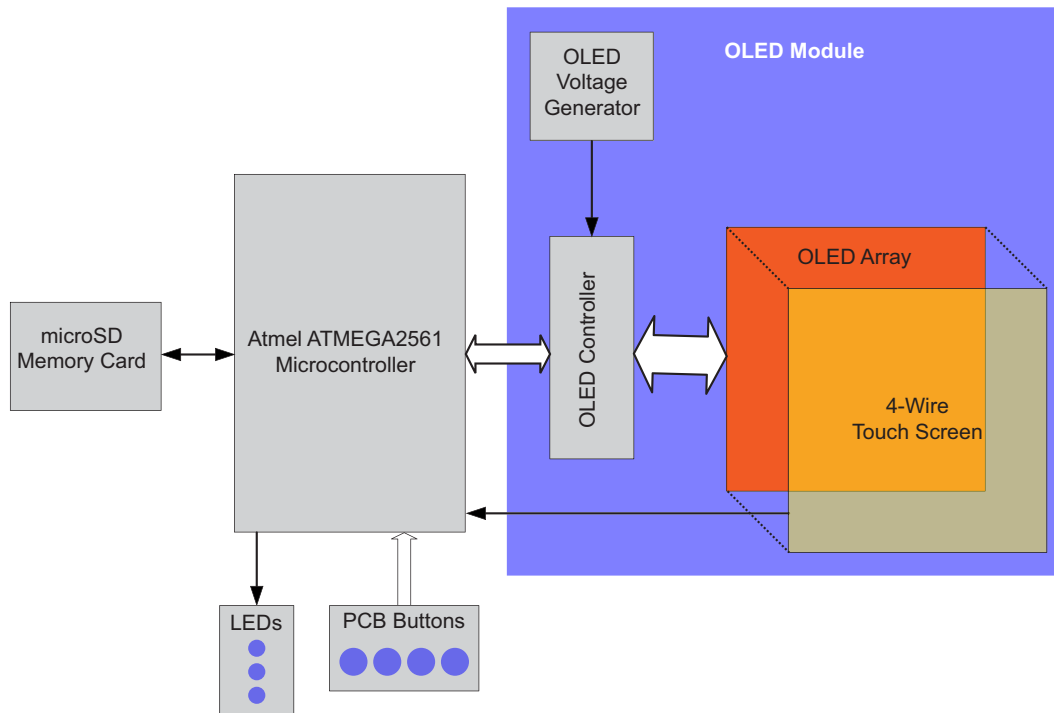

Figure 4. CFAL12864L-G-B2TS, CFAL12864L-Y-B2TS, CFAL12864L-G-B6TS, CFAL12864L-Y-B6TS, CFAL12864Z-G-B2TS, CFAL12864Z-Y-B2TS, CFAL12864Z-G-B6TS, CFAL12864Z-W-B6TS, and CFAL12864Z-Y-B6TS

CONTENTS OF HARDWARE DESIGN FOLDER

The zipped folder at <http://www.crystalfontz.com/product/CFA10009.html> includes the complete hardware design of the CFA10009 Demonstration Board.

- Schematic.
- PCB layout.
- Bill Of Materials (BOM) as an XLS spreadsheet.
- Simple OLED initialization code and bitmap display code.

The schematic and PCB layout were created with CadSoft EAGLE. EAGLE is a capable and low-cost electrical CAD system. You can download a freeware light edition of EAGLE from <http://www.cadsoft.de/> to load, view, and print the schematic and layout files.



CARE AND HANDLING PRECAUTIONS

The kit is sold with a module mounted on it. If you attempt to modify the board to work with other modules, the warranty is void. Do not disassemble or modify the CFA10009 Demonstration Board Kit.

For optimum operation of the module and demonstration board and to prolong their life, please follow the precautions below.

ESD (ELECTRO-STATIC DISCHARGE)

The circuitry is industry standard CMOS logic and susceptible to ESD damage. Please use industry standard antistatic precautions as you would for any other PCB such as expansion cards or motherboards. Ground your body, work surfaces, and equipment.

AVOID SHOCK, IMPACT, TORQUE, OR TENSION

- Do not expose the demonstration board and module to strong mechanical shock, impact, torque, or tension.
- Do not drop, toss, bend, or twist the demonstration board and module.
- Do not place weight or pressure on the demonstration board and module.

OPERATION

- The module ships with a protective film over the display. Please peel off the protective film slowly. Peeling off the protective film abruptly may generate static electricity.
- Use only the included AC adapter to power the board.
- Observe the operating temperature limitations for the module: from -20°C minimum to +70°C maximum with minimal fluctuations. Operation outside of these limits may shorten the life and/or harm the display.
- Operate away from dust, moisture, and direct sunlight.

CLEANING

- The polarizer (laminated to the glass) is soft plastic. The soft plastic is easily scratched or damaged. Be very careful when you clean the polarizer.
- Do not clean the polarizer with liquids. Do not wipe the polarizer with any type of cloth or swab (for example, Q-tips).
- Use the removable protective film to remove smudges (for example, fingerprints) and any foreign matter. If you no longer have the protective film, use standard transparent office tape (for example, Scotch® brand “Crystal Clear Tape”). If the polarizer is dusty, you may carefully blow it off with clean, dry, oil-free compressed air.

STORAGE AND RECYCLING



- Store in an ESD-approved container away from dust, moisture, and direct sunlight.
- Observe the storage temperature limitations: from -30°C minimum to +80°C maximum with minimal fluctuations. Rapid temperature changes can cause moisture to form, resulting in permanent damage.
- Do not allow weight to be placed on the modules while they are in storage.
- Please recycle the demonstration board and module at an approved facility.