



Crystalfontz America, Incorporated

INTELLIGENT SERIAL LCD MODULE SPECIFICATIONS



Crystalfontz Model Number	CFA635-TMF-KL (Sold separately or as part of a kit.)
Hardware Version	Revision v1.1, July 2008
Firmware Version	Revision s1.6, May 2010
Data Sheet Version	Revision 2.1, October 2010
Product Pages	http://www.crystalfontz.com/product/CFA635TMFKL.html

Crystalfontz America, Incorporated

12412 East Saltese Avenue
Spokane Valley, WA 99216-0357

Phone: 888-206-9720

Fax: 509-892-1203

Email: techinfo@crystalfontz.com

URL: www.crystalfontz.com



REVISION HISTORY

HARDWARE CFA635 LCD MODULE (CFA635-TMF-KL identical to USB version)	
2010/06/01	Current Hardware Revision: v1.1 (revision number has not changed) Changes: <ul style="list-style-type: none">● Effective June 2010, we are transitioning to an improved keypad from 10.5 mm to 12.00 mm high. See PCN 10282.● Factories have ISO certification.
2009/06/01	Hardware Revision: v1.1 (revision number has not changed) Change: Improved bezel. Changed from nickel plated bezel to stainless steel bezel.
2008/07/01	New Hardware Revision: v1.1 Change since last revision (v1.0): Improved backlight. Display is lit more evenly, contrast can be adjusted to higher, and lifetime is longer.
2005/08/01	Hardware Version: v1.0 Start Public Version Tracking.

FIRMWARE	
2010/05/24	Current Firmware Revision: s1.6 Changes since last revision (s1.3): <ul style="list-style-type: none">● Improved reset function to make module less sensitive to supply variations.● Fixed range checking for command 0 (0x00): Ping Command (Pg. 29).● Command 1 (0x01): Get Hardware & Firmware Version (Pg. 29) returns: "CFA635:h1.1,s1.6".
2005/06/01	Start Public Version Tracking Firmware Revision: s1.3 New firmware. (CFA635 v1.3 USB module firmware was modified for this serial module.) Command 1: Get Hardware & Firmware Version returns: "CFA635:h1.0,s1.3".



DATA SHEET	
2010/10/07	<p>Current Data Sheet Revision: v2.1 Changes since last revision (v2.0):</p> <ul style="list-style-type: none">● Wherever listed or shown, improved explanation of module depth specifications with and without keypad. Module has not changed.● In Absolute Maximum Ratings (Pg. 20), added important note on specifications.● Slightly modified specifications in Typical Current Consumption (Pg. 20) to reflect backlight improvement made 2008/07/01.● In H1 Pin Assignments - Includes GPIO Connections (Pg. 25) figure, corrected from "F4P" to "LCD Tx / Host Rx" and from "F4T" to "LCD Rx/ Host Tx". Only the USB version of the CFA635 has a fourth fan.● In APPENDIX A: SAMPLE CODE (INCLUDES ALGORITHMS TO CALCULATE THE CRC) (Pg. 48), added Algorithm 7: For PIC18F8722 or PIC18F2685 (Pg. 57).● Wherever needed, made minor modifications in text and illustrations to improve clarity. Includes how Hardware revisions are listed above.



DATA SHEET (Continued)	
2010/08/04	<p>Data Sheet Revision: v2.0 Changes since last revision (v1.0)</p> <ul style="list-style-type: none">● Wherever listed, deleted information on optional SCAB (System Cooling Accessory Board). The SCAB is not supported for this module. It is supported for the series of CFA635-xxx-KU and CFA635-xxx-KS modules.● Added boxed note "Fine Print" at the bottom of this Revision History. Please read these disclaimers.● Removed PDF sticky note titled "Changes" from this Revision History. The note read "2008-10-07 Corrected specification of GPIO pull-up/pull-down mode resistance values from "approximately 5Ω" to "approximately 5kΩ". Note is no longer needed because document has been revised.● Reorganized content, improved drawings, and edited to improve readability.● Wherever listed, deleted dash ("-") from module part numbers to match how they now appear on our website without the dash ("-").● Wherever listed, added dash ("-") to cable part numbers to match how they now appear on our website.● Wherever needed, added information about which optional CrystalFontz cables to use.● In Physical Characteristics (Pg. 14), Module Outline Drawing (Pg. 15), Jumper Locations and Functions (Pg. 16), and Keypad Detail Drawing (Pg. 17) drawings, changed keypad dimensions from "10.5 mm" to "12 mm" height and module overall depth from "20.55 mm" to "22.05 mm". We started this gradual transition June 2010.● In section Typical Current Consumption (Pg. 22), made slight changes to specifications due to improved backlight.● Added section ATX Power Supply Power and Control Connections (Pg. 23).● In Command 4 (0x04): Store Current State As Boot State (Pg. 40), deleted reference to Command 32 which is reserved for CFA631 key legends.● Deleted "SCAB Required" in the commands listed below. These commands can also be used when the module does not have the optional SCAB and is connected to the host with a CrystalFontz WR-PWR-Y25 cable.<ul style="list-style-type: none">- Command 5 (0x05): Reboot CFA635, Reset Host, or Power Off Host (Pg. 41).- Command 13 (0x0D): Set LCD Contrast (Pg. 43), corrected contrast setting from "(0-255 valid)" and "126-255 = very dark" to "(0-254 valid)" and "126-254 = very dark".- Command 28 (0x1C): Set ATX Power Switch Functionality (Pg. 51).- Command 29 (0x1D): Enable/Disable and Reset the Watchdog (Pg. 52).● In command 34 (0x22): Set or Set and Configure GPIO Pin (Pg. 54),<ul style="list-style-type: none">- Corrected specification of GPIO pull-up/pull-down mode resistance values from "approximately 5Ω" to "approximately 5kΩ".- Clarified parameter usage in GPIOs vs GPOs.



DATA SHEET (Continued)	
2010/08/04	<ul style="list-style-type: none">● In command 35 (0x23): Read GPIO Pin Levels and Configuration State (Pg. 42),<ul style="list-style-type: none">- Corrected from "data_length: 4" to "data_length: 1".- Index for "data[0]: index of GPIO to query" previously listed only 1-4. Added 5-12.- Corrected from "5-255: reserved" to "13-255: reserved".- Improved LED descriptions for H1 pins. Pins did not change.- Clarified parameter usage in GPIOs versus GPOs.● Corrected references from J8 and J9 connectors (CFA633 connectors) to H1 and H2 (CFA635 connectors). Connectors were labeled correctly in drawings and have not changed.● Please read expanded section MODULE RELIABILITY AND LONGEVITY (Pg. 59).● In APPENDIX C: SAMPLE CODE (INCLUDES ALGORITHMS TO CALCULATE THE CRC) (Pg. 67),<ul style="list-style-type: none">- Added section with hypertext links to our free downloadable code.- Added section Algorithm 2B: "C" Improved Bit Shift Implementation (Pg. 70). This is a simplified algorithm that implements the CRC.- In sample code for Algorithm 1: "C" Table Implementation (Pg. 67) and Algorithm 2: "C" Bit Shift Implementation (Pg. 68), added typedefs for "ubyte" and "word".- In Algorithm 6: "Perl" Table Implementation (Pg. 75), corrected code from "my \$packet = \$type . \$length . \$data ;" to "my \$packet = chr(hex \$type) .chr(hex \$length) .chr(hex \$data);".● Reorganized content, improved drawings, and edited to improve readability.
2007/05/15	Data Sheet Revision: v1.0 New Data Sheet.



The Fine Print

Certain applications using CrystalFontz America, Inc. products may involve potential risks of death, personal injury, or severe property or environmental damage ("Critical Applications"). CRYSTALFONTZ AMERICA, INC. PRODUCTS ARE NOT DESIGNED, INTENDED, AUTHORIZED, OR WARRANTED TO BE SUITABLE FOR USE IN LIFE-SUPPORT APPLICATIONS, DEVICES OR SYSTEMS OR OTHER CRITICAL APPLICATIONS. Inclusion of CrystalFontz America, Inc. products in such applications is understood to be fully at the risk of the customer. In order to minimize risks associated with customer applications, adequate design and operating safeguards should be provided by the customer to minimize inherent or procedural hazard. Please contact us if you have any questions concerning potential risk applications.

CrystalFontz America, Inc. assumes no liability for applications assistance, customer product design, software performance, or infringements of patents or services described herein. Nor does CrystalFontz America, Inc. warrant or represent that any license, either express or implied, is granted under any patent right, copyright, or other intellectual property right of CrystalFontz America, Inc. covering or relating to any combination, machine, or process in which our products or services might be or are used.

The information in this publication is deemed accurate but is not guaranteed.

Company and product names mentioned in this publication are trademarks or registered trademarks of their respective owners.

Copyright © 2010 by CrystalFontz America, Inc., 12412 East Saltese Avenue, Spokane Valley, WA 99216-0357 U.S.A.



CONTENTS

INTRODUCTION	10
MAIN FEATURES	10
ORDERING INFORMATION	11
Module Variant Choices	11
Module Classification Information	12
Kit Configuration Choices	13
MECHANICAL SPECIFICATIONS	14
Physical Characteristics	14
Module Outline Drawing	15
Jumper Locations and Functions	17
Keypad Detail Drawing	18
ELECTRICAL SPECIFICATIONS	19
System Block Diagram	19
Viewing Direction	20
Driving Method	20
Absolute Maximum Ratings	20
DC Characteristics	20
Typical Current Consumption	20
ESD (Electro-Static Discharge) Specifications	21
Additional Criteria	22
CONNECTION INFORMATION	22
ATX Power Supply Power and Control Connections	22
CFA635-TMF-KL LCD Module Connectors	24
Pin Assignments on LCD Module H1 and H2 Connectors	25
H1 Pin Assignments - Includes GPIO Connections	25
H2 Pin Assignments - Includes GPO Connections	26
Power Connection to Host	26
HOST COMMUNICATIONS	27
Packet Structure	27
About Handshaking	28
Report Codes	28
0x80: Key Activity	28
0x81: Reserved for Fan Speed Report (SCAB required)	29
Command Codes	29
0 (0x00): Ping Command	29
1 (0x01): Get Hardware & Firmware Version	29
2 (0x02): Write User Flash Area	29
3 (0x03): Read User Flash Area	30
4 (0x04): Store Current State As Boot State	30
5 (0x05): Reboot CFA635, Reset Host, or Power Off Host	30
6 (0x06): Clear LCD Screen	32
9 (0x09): Set LCD Special Character Data	32
10 (0x0A): Read 8 Bytes of LCD Memory	33
11 (0x0B): Set LCD Cursor Position	33



CONTENTS, CONTINUED

12 (0x0C): Set LCD Cursor Style	33
13 (0x0D): Set LCD Contrast	34
14 (0x0E): Set LCD & Keypad Backlight	34
17 (0x11): Reserved for Set Fan Power (SCAB required)	34
22 (0x16): Send Command Directly to the LCD Controller	35
23 (0x17): Configure Key Reporting	35
24 (0x18): Read Keypad, Polled Mode	35
28 (0x1C): Set ATX Power Switch Functionality	37
29 (0x1D): Enable/Disable and Reset the Watchdog	38
30 (0x1E): Read Reporting & Status	39
31 (0x1F): Send Data to LCD	40
33 (0x21): Set Baud Rate	40
34 (0x22): Set or Set and Configure GPIO Pin	40
35 (0x23): Read GPIO Pin Levels and Configuration State	42
CHARACTER GENERATOR ROM (CGROM)	44
MODULE RELIABILITY AND LONGEVITY	45
Module Reliability	45
Module Longevity (EOL / Replacement Policy)	45
CARE AND HANDLING PRECAUTIONS	46
APPENDIX A: SAMPLE CODE (INCLUDES ALGORITHMS TO CALCULATE THE CRC)	48
Sample Code	48
Algorithms to Calculate the CRC	48
Algorithm 1: "C" Table Implementation	48
Algorithm 2: "C" Bit Shift Implementation	49
Algorithm 2B: "C" Improved Bit Shift Implementation	51
Algorithm 3: "PIC Assembly" Bit Shift Implementation	51
Algorithm 4: "Visual Basic" Table Implementation	53
Algorithm 5: "Java" Table Implementation	54
Algorithm 6: "Perl" Table Implementation	56
Algorithm 7: For PIC18F8722 or PIC18F2685	57
APPENDIX B: QUALITY ASSURANCE STANDARDS	60



LIST OF FIGURES

Figure 1. Module Outline Drawing (2 pages below) -----	15
Figure 2. Jumper Locations and Functions -----	17
Figure 3. Keypad Detail Drawing -----	18
Figure 4. System Block Diagram -----	19
Figure 5. ATX Power Supply and Control Connections using CrystalFontz WR-PWR-Y25 Cable -----	23
Figure 6. CFA635 Serial LCD Module Connectors H1 and H2 -----	24
Figure 7. Pin Assignments on CFA635 Serial LCD Module H1 Connector (Includes GPIOs) -----	25
Figure 8. Pin Assignments on CFA635 Serial LCD Module H2 Connector (Includes GPIOs) -----	26
Figure 9. Character Generator ROM (CGROM) -----	44



INTRODUCTION

The CFA635 series was originally conceived as an integrated easy-to-use front panel for 1U internet appliances. Since USB is the standard low-speed interface for these appliances, the CFA635 design was USB. Shortly after its introduction, we received requests for a serial version of CFA635. Many embedded designs could use the integrated LCD, keypad, LEDs, and compact form factor of the CFA635, but these embedded applications rarely had the resources to implement the USB host interface.

The *CFA635-TMF-KL* and *CFA635-TMF-KS* address this need by providing serial variants of the CFA635. Both variants of the serial CFA635 use a special version of firmware that brings the two UART pins (Tx & Rx) of the CFA635's microcontroller to one of the CFA635's existing expansion connectors.

The *CFA635-TMF-KL* simply exposes these UART Tx & Rx (inverted, logic level, 0v to 5v nominal) signals on pin 1 and pin 2 of the CFA635's expansion header H1. If your embedded processor is in close physical proximity to the CFA635, you can cable its UART Rx and Tx pins directly to the CFA635-TMF-KL's Tx and Rx pins. No RS-232 level translators are required on either end.

The *CFA635-TMF-KS* is a CFA635-TMF-KL with an RS-232 level translator board (CFA-RS232-01) attached. The CFA635-TMF-KS is the correct choice if your embedded controller or host system has a "real" RS-232 serial port (-10v to +10v "full swing" serial interface, typically through a UART).

NOTE

The CFA635-TMF-KL has a USB connector but it is disabled and cannot be used.

MAIN FEATURES

- Large easy-to-read 20 characters x 4 lines LCD has a large display area in a compact size. Fits in a 1U rack mount case (37 mm overall height).
- White edge LED backlit with STN blue negative mode LCD (displays light characters on blue background).
- Integrated blue LED backlit translucent silicone keypad.
- Adjustable backlight contrast.
- ATX power supply control functionality allows the keypad buttons on the CFA635-TMF-KL to replace the power and reset switches on your system, simplifying front panel design. Optional 16-pin Crystalfontz [WR-PWR-Y25](#) ATX power switch cable may be used for direct connection to the host's PC power supply.
- Four bicolor (red + green) LED indicators. The LEDs' brightness can be set by the host software, which allows smoothly mixing the LEDs to produce other colors (for example, yellow and orange).
- LCD characters are contiguous in both X and Y directions to allow the host software to display "gapless" bar graphs in horizontal or vertical directions.
- Unique "Scrolling Marquee" feature continuously scrolls a message across the display without host intervention.
- Fully decoded keypad: any key combination is valid and unique.
- Robust packet based communications protocol with 16-bit CRC.
- Built-in microcontroller.
- Nonvolatile memory capability (EEPROM):
 - Customize the "power-on" display settings.
 - 16-byte "scratch" register for storing IP address, netmask, system serial number . . .



- The CFA635-TMF-KL may be used with the optional CrystalFontz System Cooling Accessory Board ([SCAB](#)) for controlling up to three fans and up to 32 temperature sensors. For assistance, please contact Technical Support (888-206-9720 or email techinfo@crystalfontz.com).
- RoHS compliant.
- Factories have ISO certification.
- If you need a CE approved module, please see our XES635 USB series (<http://www.crystalfontz.com/product/XES635BK-YYE-KU.html>, <http://www.crystalfontz.com/product/XES635BK-TMF-KU.html>, or <http://www.crystalfontz.com/product/XES635BK-TFE-KU.html>). The CFA635-TMF-KL does not have CE certification because it is not an end product. The module requires power and communications from another system in order to operate.

ORDERING INFORMATION

MODULE VARIANT CHOICES

PART NUMBER	FLUID	LCD GLASS COLOR	IMAGE	POLARIZER FILM	BACKLIGHTS
CFA635-TMF-KL	STN	blue	negative	transmissive	LCD: white edge LEDs Keypad: blue LEDs
Additional variants available (same form factor and interface).					
CFA635-YYE-KL	STN	yellow-green	positive	transflective	LCD: yellow-green edge LEDs Keypad: yellow-green LEDs
CFA635-TFE-KL	FSTN	neutral	positive	transflective	LCD: white edge LEDs Keypad: white LEDs
<p>The CFA635 series includes:</p> <ul style="list-style-type: none"> <input type="checkbox"/> For USB, see www.crystalfontz.com/products/635/. <input type="checkbox"/> A serial interface using an RS-232 level translator board (part numbers end in "-KS"). If your embedded controller or host system has a "real" RS-232 serial port (-10v to +10v "full swing" serial interface, typically through a UART), see www.crystalfontz.com/products/635serial/. <input type="checkbox"/> An external enclosure with a captive USB "A" cable connection. See www.crystalfontz.com/product/XES635BKTMFKU.html. 					



MODULE CLASSIFICATION INFORMATION

CFA 635 - T M F - K L
① ② ③ ④ ⑤ ⑥ ⑦

①	Brand	CrystalFontz America, Inc.
②	Model Identifier	635
③	Backlight Type & Color	T – LED, white
④	Fluid Type, Image (positive or negative), & LCD Glass Color	M – STN, negative, blue
⑤	Polarizer Film Type, Normal (NT) Temperature Range, & View Angle (O'Clock)	F – Transmissive, NT ¹ , 12:00
⑥	Special Code 1	K – Manufacturer's code
⑦	Special Code 2	L – Serial, inverted, logic level, 0v to +5v nominal
¹ Normal Temperature Range is 0°C minimum to +50°C maximum.		



KIT CONFIGURATION CHOICES

Accessories for the CFA635-xxx-KL or CFA635-xxx-KS are:

- Bracket*: a 5.25-inch half-height drive bay mounting bracket.
- SLED*: a chassis that fits in 5.25-inch half-height drive bay. The SLED can hold a CFA635 module, a [SCAB \(System Cooling Accessory Board\)](#), and a 3.5-inch hard disk drive. (Hard drive is not included.)
- Overlay*: an overlay for the front of module with a display window of clear Lexan, a thick hard-coated polycarbonate material. Overlay choices are black brushed anodized aluminum, silver brushed anodized aluminum, beige plastic, and black plastic.

Choose your CrystalFontz cables here: <https://www.crystalfontz.com/cart/pricing.php?cat=2>.

Kits for CFA635-xxx-KL or CFA635-xxx-KS are available by special order only. (Kits for CFA635-xxx-KU are available on our website.) Use the following part number classification scheme to determine your kit configuration part number. Please send the kit configuration part number and required quantity along with the cable quantities and part numbers for each kit that you need in an email to sales@crystalfontz.com or call (888) 206-9720. Our logistics team will work with the engineering group to provide you with a DP (Defined Part) number, prices, MOQ (Minimum Order Quantity), and lead time.

Kit Configuration Part Number Classification

D[type]635[overlay]-[variant]-K[interface]

[type]	[overlay]	[variant]	[interface]
B = Bracket S = SLED	AK = Black Aluminum AL = Silver Aluminum BG = Beige Plastic BK = Black Plastic	TFE = dark characters, light background TMF = light characters, blue background YYE = dark characters, yellow-green background	S = RS232 L = logic level

Kit Configuration Part Number Example

DB635AL-TMF-KL

[type]	[overlay]	[variant]	[interface]
B = Bracket	AL = Silver Aluminum	TMF = light characters, blue background	L = logic level



MECHANICAL SPECIFICATIONS

PHYSICAL CHARACTERISTICS

ITEM	SIZE
Module Overall Dimensions	
Width and Height	142.0 (W) mm x 37.0 (H) mm
Module Depth: without Keypad, with Connectors with Keypad, with Connectors	15.30 mm nominal 20.80 mm nominal 21.10 mm maximum
Viewing Area	82.95 (W) x 27.50 (H) mm
Active Area	77.95 (W) x 22.35 (H) mm
5x7 Standard Character Size	3.20 (W) x 4.85 (H) mm
6x8 Matrix (can be used for special characters or graphics)	3.90 (W) X 5.60 (H) mm
Dot Size	0.60 (W) x 0.65 (H) mm
Dot Pitch	0.65 (W) x 0.70 (H) mm
Keystroke Travel (approximate)	2.4 mm
Weight	66 grams (typical)



MODULE OUTLINE DRAWING

Figure 1. Module Outline Drawing (2 pages below)

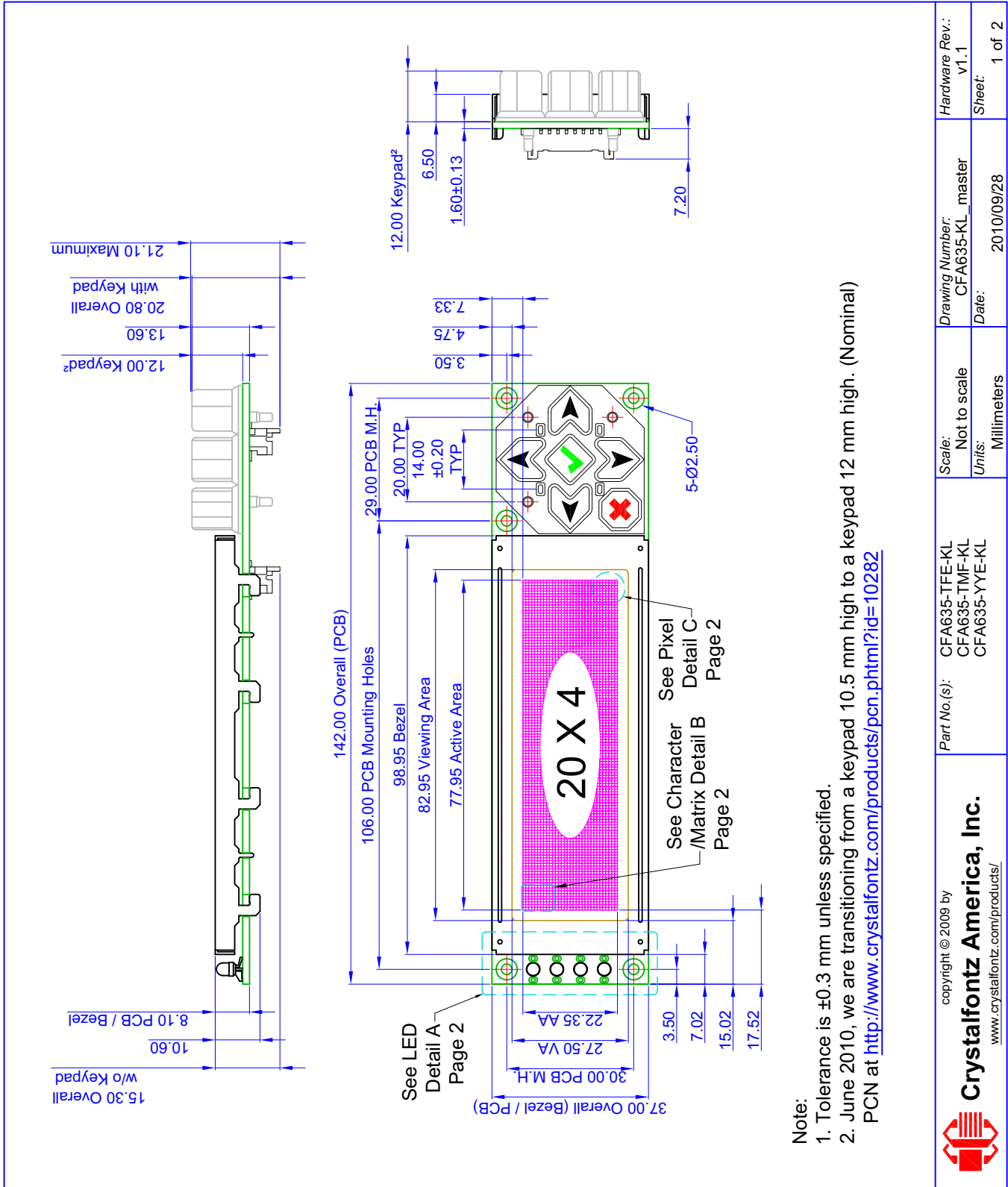

Part No.(s): CFA635-TFE-KL CFA635-TMF-KL CFA635-YYE-KL	Scale: Not to scale Units: Millimeters	Drawing Number: CFA635-KL_master Date: 2010/09/28	Hardware Rev.: v1.1 Sheet: 1 of 2
---	--	---	---



JUMPER LOCATIONS AND FUNCTIONS

This CFA635 Serial LCD module has eight jumpers. Only JPF may be changed. This jumper is normally open. The jumper may be closed by melting a ball of solder across the gap. To reopen the jumper, remove the solder. Solder wick works well for this.

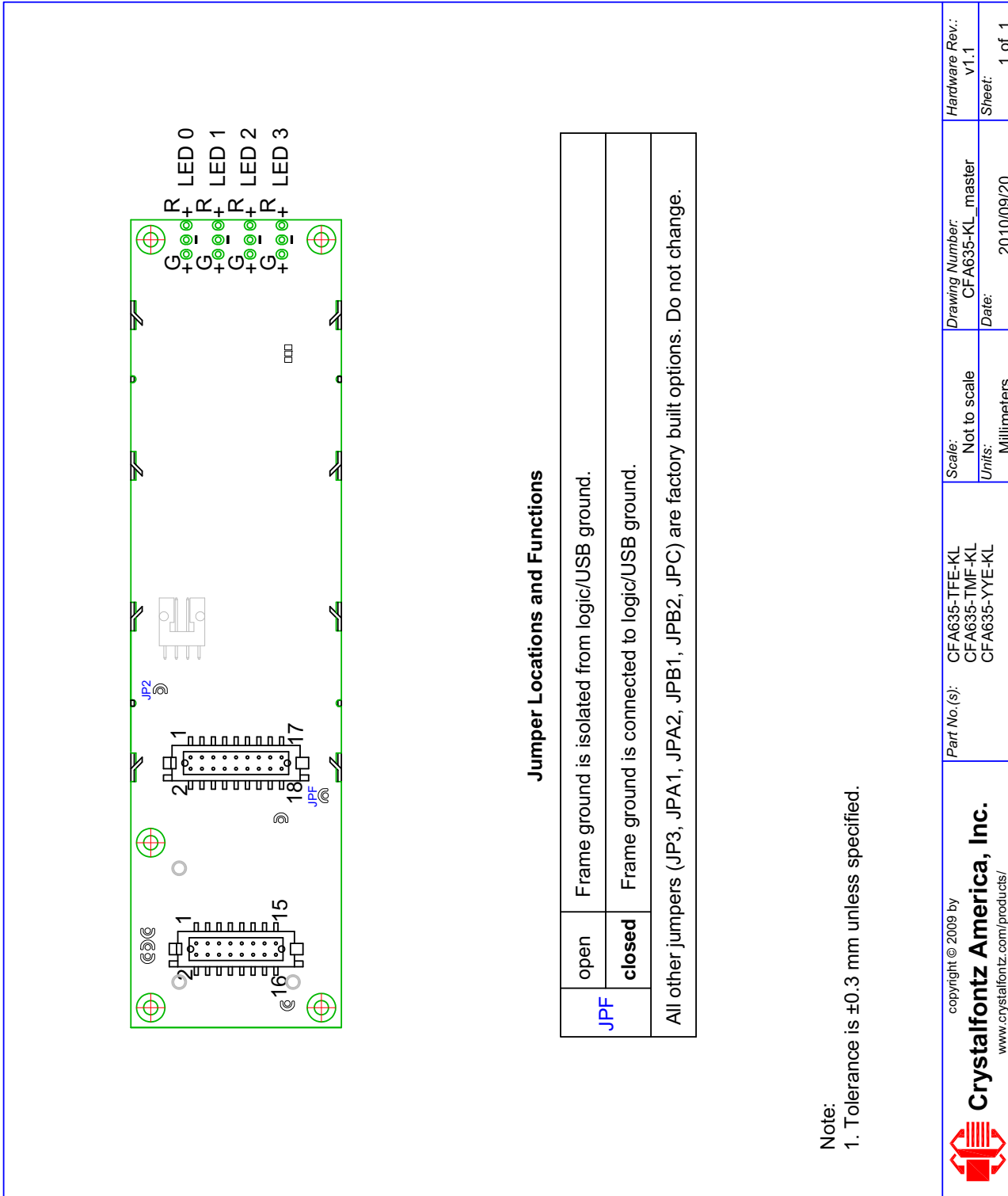
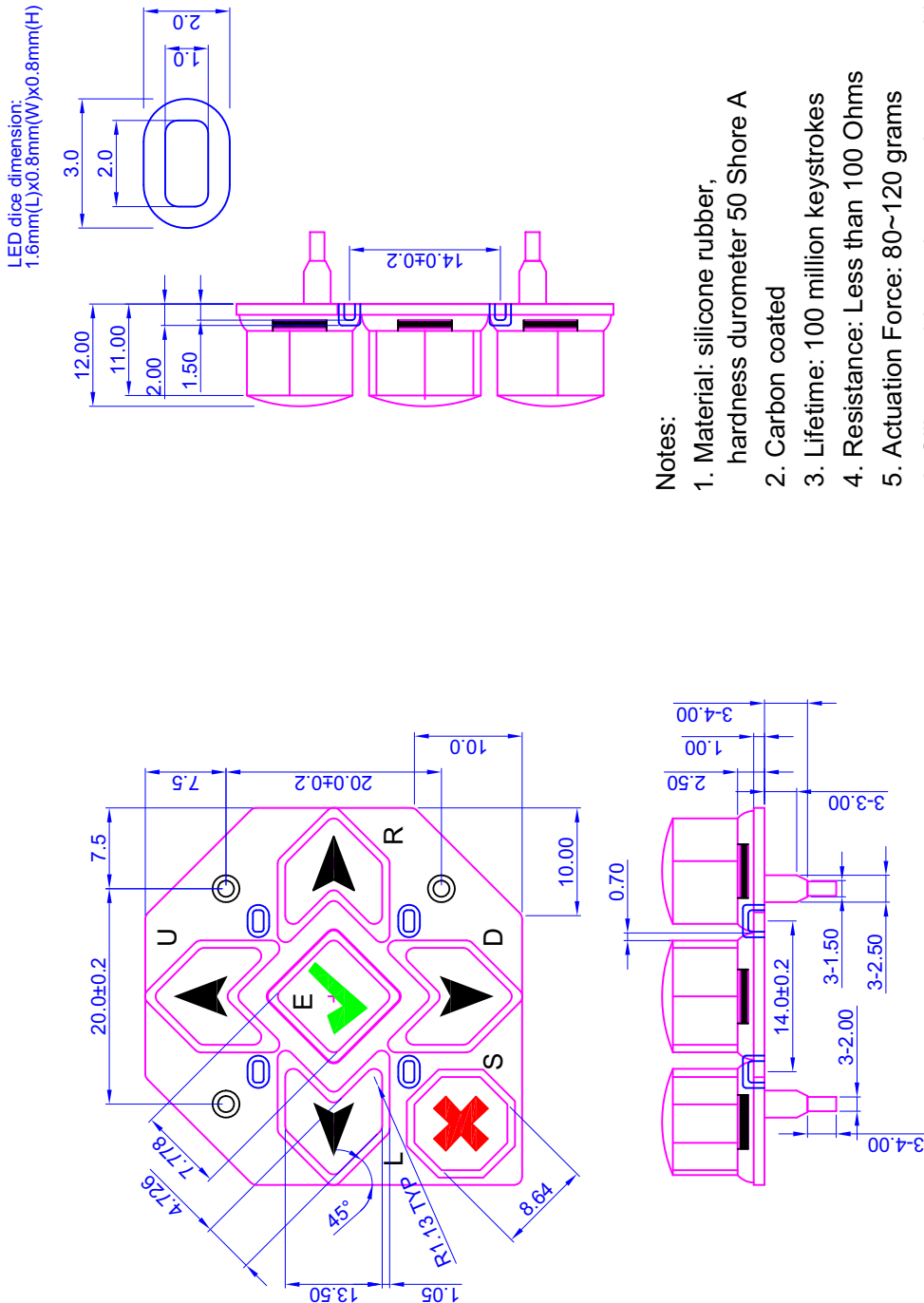

Figure 2. Jumper Locations and Functions



KEYPAD DETAIL DRAWING

June 2010, we are transitioning from a keypad 10.5 mm high to a keypad 12 mm high. PCN at <http://www.crystalfontz.com/products/pcn.phtml?id=10282>



- Notes:**
1. Material: silicone rubber, hardness durometer 50 Shore A
 2. Carbon coated
 3. Lifetime: 100 million keystrokes
 4. Resistance: Less than 100 Ohms
 5. Actuation Force: 80~120 grams
 6. Silicone rubber color: translucence white
 7. All corners have a fillet radius of 0.75 mm

Scale:	Not to scale	Drawing Number:	Keypad_Detail_master	Hardware Rev.:	v1.1
Units:	Millimeters	Date:	2010/09/09	Sheet:	1 of 1
Part No. (s):	CFA635 Keypad Detail				
copyright © 2009 by CrystalFontz America, Inc. www.crystalfontz.com/products/					

Figure 3. Keypad Detail Drawing



ELECTRICAL SPECIFICATIONS

SYSTEM BLOCK DIAGRAM

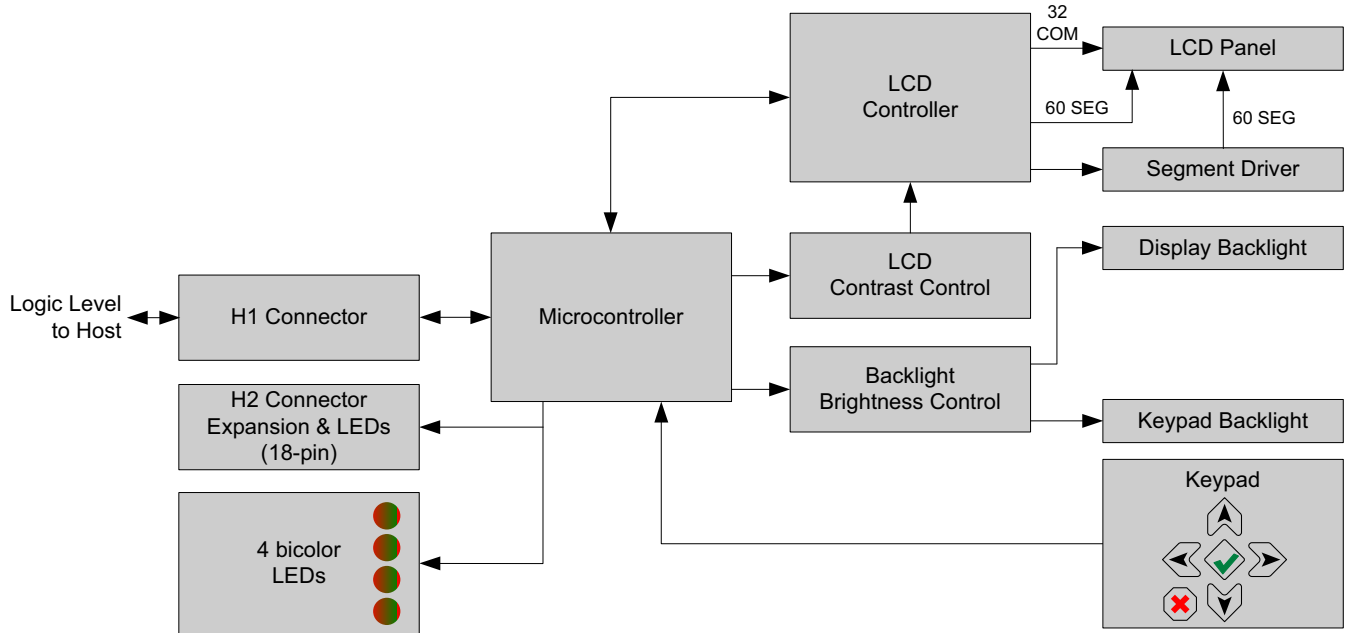

Figure 4. System Block Diagram



VIEWING DIRECTION

Viewing Direction	12 o'clock
-------------------	------------

DRIVING METHOD

DRIVING METHOD	SPECIFICATION
Duty	1/32
Bias	6.7

ABSOLUTE MAXIMUM RATINGS

ABSOLUTE MAXIMUM RATINGS	SYMBOL	MINIMUM	MAXIMUM
Operating Temperature	T _{OP}	0°C	+50°C
Storage Temperature	T _{ST}	-10°C	+60°C
Supply Voltage for Logic	V _{DD}	0v	+5.25v
<p>Note These are stress ratings only. Functional operation of the module at these or any other conditions beyond those listed under DC Characteristics (Pg. 20) is not implied.</p> <p>Extended exposure to the absolute maximum ratings listed above may affect device reliability. Stresses beyond those listed above can cause permanent damage.</p>			

DC CHARACTERISTICS

DC CHARACTERISTICS	SYMBOL	MINIMUM	TYPICAL	MAXIMUM
Supply voltage for driving the serial LCD module.	V _{DD} - V _O	+4.75v	+5.0v	+5.25v
Logic Input High Voltage	V _{IH}	+2.1v		V _{DD}
Logic Input Low Voltage	V _{IL}	V _{SS}		+0.08v



ITEMS ENABLED			TYPICAL CURRENT CONSUMPTION	
Logic	LCD and Keypad Backlights	All Indicator LEDs (4 Red + 4 Green)	V _{DD} =4.75V	V _{DD} =5.25V
X	-	-	25 mA	26 mA
X	X	-	124 mA	148 mA
X	-	X	142 mA	163 mA
X	X	X	240 mA	285 mA

GPIO CURRENT LIMITS	SPECIFICATION
Sink	25 mA
Source	10 mA

ESD (ELECTRO-STATIC DISCHARGE) SPECIFICATIONS

The circuitry is industry standard CMOS logic and is susceptible to ESD damage. Please use industry standard antistatic precautions as you would for any other static sensitive devices such as expansion cards, motherboards, or integrated circuits. Ground your body, work surfaces, and equipment.



ADDITIONAL CRITERIA

ADDITIONAL CRITERIA	SPECIFICATION
Backlight PWM Frequency	300 Hz nominal
<i>PWM is Pulse Width Modulation. PWM is a way to simulate intermediate levels by switching a level between full on and full off. PWM can be used to control the brightness of LED backlights, relying on the natural averaging done by the human eye, as well as for controlling fan power.</i>	

CONNECTION INFORMATION

ATX POWER SUPPLY POWER AND CONTROL CONNECTIONS

ATX power supply control functionality allows the buttons on the CFA635 to replace the power and reset button on your system, simplifying front panel design.

NOTE

The GPIO pins used for ATX control must not be configured as user GPIO. The GPIO pins must be configured to their default drive mode in order for the ATX functions to work correctly. These settings are factory default but may be changed by the user. Please see command [34 \(0x22\): Set or Set and Configure GPIO Pin \(Pg. 40\)](#).

When configuring the CFA635 for ATX functionality, open jumper JP2 in order to ensure correct operation. See [Jumper Locations and Functions \(Pg. 17\)](#) for jumper positions and locations. This configuration for the CFA635 is powered from the PC's VSB signal, the "stand-by" or "always-on" +5v ATX power supply output, on pins 15 and 16 of the H1 connector.

GPIO[1] ATX Host Power Sense

Since the CFA635-TMF-KL must act differently depending on whether the host's power supply is on or off, you must also connect the host's "switched +5v" to GPIO[1]. This GPIO line functions as POWER SENSE. The POWER SENSE pin is configured as an input with a pull-down, 5kΩ nominal.

GPIO[2] ATX Host Power Control

The motherboard's power switch input is connected to GPIO[2]. This GPIO line functions as POWER CONTROL. The POWER CONTROL pin is configured as a high impedance input until the LCD module instructs the host to turn on or off. Then it will change momentarily to low impedance output, driving either low or high depending on the setting of POWER INVERT. See command [28 \(0x1C\): Set ATX Power Switch Functionality \(Pg. 37\)](#).

GPIO[3] ATX Host Reset Control

The motherboard's reset switch input is connected to GPIO[3]. This GPIO line functions as RESET. The RESET pin is configured as a high-impedance input until the LCD module wants to RESET the host. Then it will change momentarily to low impedance output, driving either low or high depending on the setting of RESET_INVERT. See command [28 \(0x1C\): Set ATX Power Switch Functionality \(Pg. 37\)](#). This connection is also used for the hardware watchdog.



Connection Overview

ATX Power Supply & Control Connections	Pins on CFA635-TMF-KL's Connector H1
V _{SB} , +5v	Pin 16
V _{SB} , Ground	Pin 13
GPIO[1] Host POWER-ON SENSE	Pin 12
GPIO[2] Host POWER CONTROL	Pin 9
GPIO[3] Host RESET CONTROL	Pin 10

Details of Connection using WR-PWR-Y25 Cable

The optional Crystalfontz [WR-PWR-Y25](#) cable simplifies ATX power control connections, allowing all ATX power supply control functionality through the 's H1 connector.

Below is an illustration of how the optional Crystalfontz [WR-PWR-Y25](#) cable connects to the CFA635's connector H1 and your system's motherboard and ATX power supply:

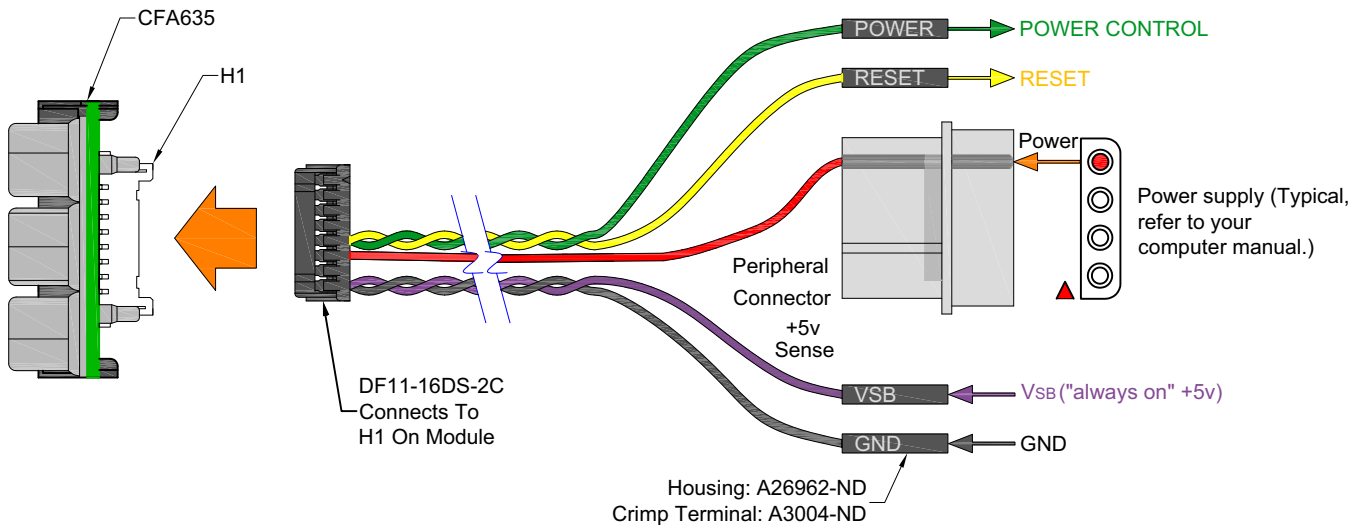

Figure 5. ATX Power Supply and Control Connections using Crystalfontz WR-PWR-Y25 Cable



CFA635-TMF-KL LCD MODULE CONNECTORS

The CFA635 Serial LCD Module has two connectors on its back side, H1 and H2.

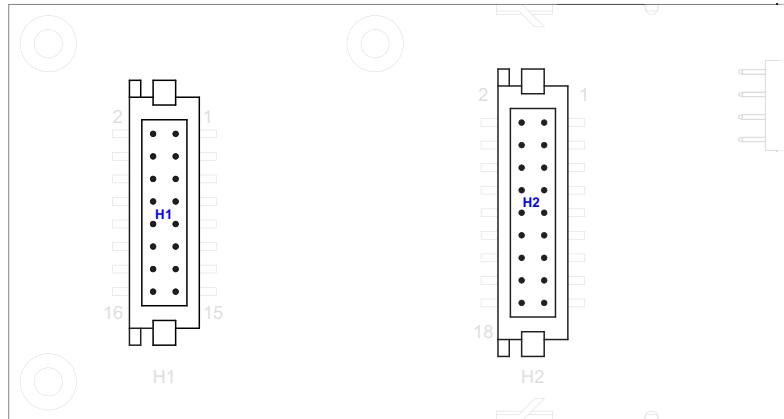

Figure 6. CFA635 Serial LCD Module Connectors H1 and H2

1. The H1 male 16-pin 2 mm connector provides the TTL serial communication and GPIO connections. For pin assignments, see [H1 Pin Assignments - Includes GPIO Connections \(Pg. 25\)](#).
2. The H2 male 18-pin 2 mm connector provides GPIO connections, including those that drive the front panel LEDs. For pin assignments, see [H1 Pin Assignments - Includes GPIO Connections \(Pg. 25\)](#).



PIN ASSIGNMENTS ON LCD MODULE H1 AND H2 CONNECTORS

H1 Pin Assignments - Includes GPIO Connections

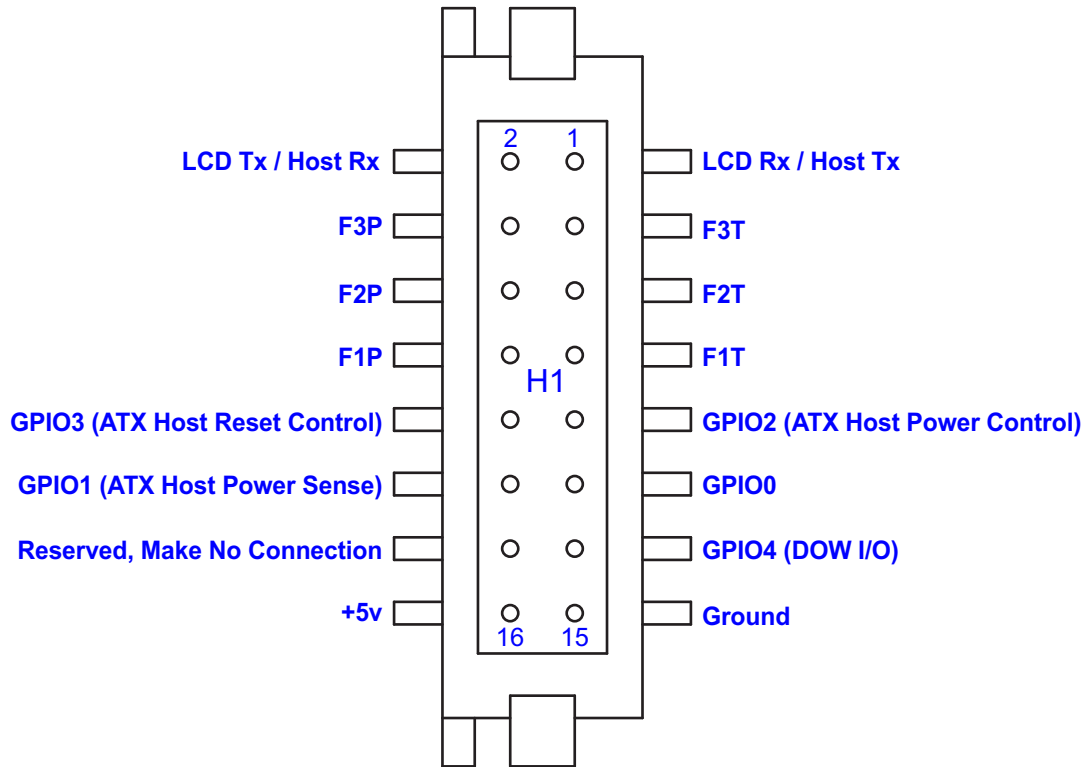

Figure 7. Pin Assignments on CFA635 Serial LCD Module H1 Connector (Includes GPIOs)

The following parts may be used to make a mating cable for H1:

- 16-position housing: Hirose DF11-16DS-2C / [Digi-Key H2025-ND](#).
- Crimping contact (tape & reel): Hirose DF11-2428SCF / [Digi-Key H1504TR-ND](#).
- Crimping contact (loose): Hirose DF11-2428SC / [Digi-Key H1504-ND](#).
- Pre-terminated interconnect wire: Hirose / [Digi-Key H3BBT-10112-B4-ND](#) is typical.



H2 Pin Assignments - Includes GPO Connections

The CFA635-TMF-KL has eight GPIO/GPO connections available on header H2. By factory default, these GPOs drive the front panel LEDs. By removing the LEDs, these GPOs could be used for other purposes.

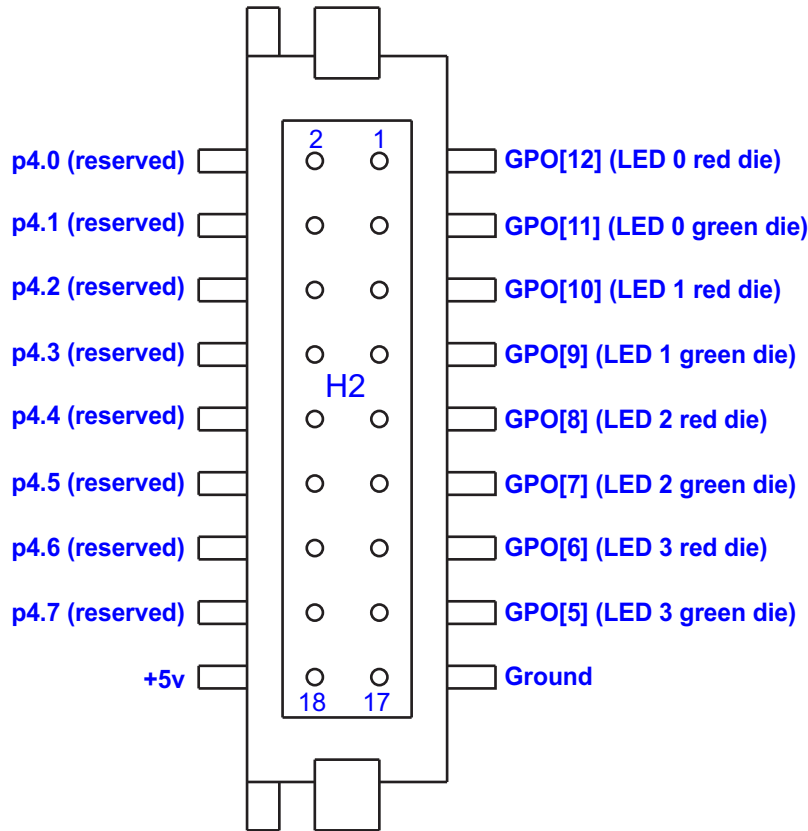

Figure 8. Pin Assignments on CFA635 Serial LCD Module H2 Connector (Includes GPIOs)

Please see the commands [34 \(0x22\): Set or Set and Configure GPIO Pin \(Pg. 40\)](#), and [35 \(0x23\): Read GPIO Pin Levels and Configuration State \(Pg. 42\)](#) below for details on how to control the GPIOs.

The following parts may be used to make a mating cable for H2:

- 18-position housing: Hirose DF11-18DS-2C / [Digi-Key H2026-ND](#).
- Terminal (tape & reel): Hirose DF11-2428SCF / [Digi-Key H1504TR-ND](#).
- Terminal (loose): Hirose DF11-2428SC / [Digi-Key H1504-ND](#).
- Pre-terminated interconnect wire: Hirose / [Digi-Key H3BBT-10112-B4-ND](#) is typical.

POWER CONNECTION TO HOST

The Crystalfontz 16-pin [WR-EXT-Y15](#) (16 inches) or the 16-pin [WR-EXT-Y19](#) (3.5 inches) cable may be useful for connecting the CFA635-TMF-KL to your host's controller board. The CFA635-TMF-KL may be used with the optional Crystalfontz System Cooling Accessory Board ([SCAB](#)) for controlling up to three fans and up to 32 temperature sensors. For assistance, please contact Technical Support (888-206-9720 or email techinfo@crystalfontz.com).



On our website, CrystalFontz supplies a demonstration and test program, [635_WinTest](#) along with its C source code. Included in the [635_WinTest](#) source is a CRC algorithm and an algorithm that detects packets. The algorithm will automatically re-synchronize to the next valid packet in the event of any communications errors. Please follow the algorithm in the sample code closely in order to realize the benefits of using the packet communications.

ABOUT HANDSHAKING

The nature of CFA635's packets makes it unnecessary to implement traditional hardware or software handshaking.

The host should wait for a corresponding acknowledge packet from the CFA635 before sending the next command packet. The CFA635 will respond to all packets within 250 mS. The host software should stop waiting and retry the packet if the CFA635 fails to respond within 250 mS. The host software should report an error if a packet is not acknowledged after several retries. This situation indicates a hardware problem — for example, a disconnected cable. Please note that some operating systems may introduce delays between when the data arrives at the physical port from the CFA635 until it is available to the user program. In this case, the host program may have to increase its timeout window to account for the additional overhead of the operating system.

The CFA635 can be configured to send several types of report packets along with regular acknowledge packets. The host should be able to buffer several incoming packets and must guarantee that it can process and remove packets from its input buffer faster than the packets can arrive given the 115200 equivalent baud rate of the VCP and the reporting configuration of the CFA635. For any modern PC or microcontroller using reasonably efficient software, this requirement will not pose a challenge.

The report packets are sent asynchronously with respect to the command packets received from the host. The host should not assume that the first packet received after it sends a command is the acknowledge packet for that command. The host should inspect the `type` field of incoming packets and process them accordingly.

REPORT CODES

The CFA635 can be configured to report three items. The CFA635 sends reports automatically when the data becomes available. Reports are not sent in response to a particular packet received from the host. The three report types are (1) 0x80: Key Activity, (2) 0x81: Reserved for Fan Speed Report (SCAB required), and (3) 0x82: Reserved for Temperature Sensor Report (SCAB required). Details are below.

0x80: Key Activity

If a key is pressed or released, the CFA635 sends a Key Activity report packet to the host. Key event reporting may be individually enabled or disabled by command [23 \(0x17\): Configure Key Reporting \(Pg. 35\)](#).

```

type = 0x80
data_length = 1
data[0] is the type of keyboard activity:
KEY_UP_PRESS           1
KEY_DOWN_PRESS        2
KEY_LEFT_PRESS        3
KEY_RIGHT_PRESS       4
KEY_ENTER_PRESS       5
KEY_EXIT_PRESS        6
KEY_UP_RELEASE        7
KEY_DOWN_RELEASE      8
KEY_LEFT_RELEASE      9
KEY_RIGHT_RELEASE     10
KEY_ENTER_RELEASE     11
KEY_EXIT_RELEASE      12
  
```



These codes are identical to the codes returned by the [CFA633](#). Please note that the CFA631 will return codes 13 through 20. (See the [CFA631](#) Data Sheet on our website for more details.)

0x81: Reserved for Fan Speed Report (SCAB required)

0x82: Reserved for Temperature Sensor Report (SCAB required)

COMMAND CODES

Below is a list of valid commands for the CFA635. Each command packet is answered by either a response packet or an error packet. The low 6 bits of the `type` field of the response or error packet is the same as the low 6 bits of the `type` field of the command packet being acknowledged.

0 (0x00): Ping Command

The CFA635 will return the Ping Command to the host.

```
type = 0x00 = 010
valid data_length is 0 to 16
data[0-(data_length-1)] can be filled with any arbitrary data
```

The return packet is identical to the packet sent, except the type will be 0x40 (normal response, Ping Command):

```
type = 0x40 | 0x00 = 0x40 = 6410
data_length = (identical to received packet)
data[0-(data_length-1)] = (identical to received packet)
```

1 (0x01): Get Hardware & Firmware Version

The CFA635 will return the hardware and firmware version information to the host.

```
type = 0x01 = 110
valid data_length is 0
```

The return packet will be:

```
type = 0x40 | 0x01 = 0x41 = 6510
data_length = 16
data[] = "CFA635:hX.X,yY.Y"
```

```
X.X is the hardware revision, "1.1" for example
yY.Y is the firmware version, "s1.6" for example
```

2 (0x02): Write User Flash Area

The CFA635 reserves 16 bytes of nonvolatile memory for arbitrary use by the host. This memory can be used to store a serial number, IP address, gateway address, netmask, or any other data required. All 16 bytes must be supplied.

```
type = 0x02 = 210
valid data_length is 16
data[] = 16 bytes of arbitrary user data to be stored in
         the CFA635's non-volatile memory
```

The return packet will be:

```
type = 0x40 | 0x02 = 0x42 = 6610
data_length = 0
```



3 (0x03): Read User Flash Area

This command will read the User Flash Area and return the data to the host.

```
type = 0x03 = 310  
valid data_length is 0
```

The return packet will be:

```
type = 0x40 | 0x03 = 0x43 = 6710  
data_length = 16  
data[] = 16 bytes user data recalled from the CFA635's non-volatile memory
```

4 (0x04): Store Current State As Boot State

The CFA635 loads its power-up configuration from nonvolatile memory when power is applied. The CFA635 is configured at the factory to display a “welcome screen” when power is applied. This command can be used to customize the welcome screen, as well as the following items:

- Characters shown on LCD, which are affected by:
 - Command [6 \(0x06\): Clear LCD Screen \(Pg. 32\)](#).
 - Command [31 \(0x1F\): Send Data to LCD \(Pg. 40\)](#).
- Special character font definitions (command [9 \(0x09\): Set LCD Special Character Data \(Pg. 32\)](#)).
- Cursor position (command [11 \(0x0B\): Set LCD Cursor Position \(Pg. 33\)](#)).
- Cursor style (command [12 \(0x0C\): Set LCD Cursor Style \(Pg. 33\)](#)).
- Contrast setting (command [13 \(0x0D\): Set LCD Contrast \(Pg. 34\)](#)).
- Backlight setting (command [14 \(0x0E\): Set LCD & Keypad Backlight \(Pg. 34\)](#)).
- Key press and release masks (command [23 \(0x17\): Configure Key Reporting \(Pg. 35\)](#)).
- ATX function enable and pulse length settings (command [28 \(0x1C\): Set ATX Power Switch Functionality \(Pg. 37\)](#)).
- Baud rate (command [33 \(0x21\): Set Baud Rate \(Pg. 40\)](#)).
- GPIO settings (command [34 \(0x22\): Set or Set and Configure GPIO Pin \(Pg. 40\)](#)).
- The front panel LED/GPO settings (command [34 \(0x22\): Set or Set and Configure GPIO Pin \(Pg. 40\)](#)).

You cannot store the fan or temperature reporting, or the fan fail-safe or host watchdog. The host software should enable these items once the system is initialized and it is ready to receive the data.

```
type = 0x04 = 410  
valid data_length is 0
```

The return packet will be:

```
type = 0x40 | 0x04 = 0x44 = 6810  
data_length = 0
```

5 (0x05): Reboot CFA635, Reset Host, or Power Off Host

This command instructs the CFA635+[WR-PWR-Y25](#) cable to simulate a power-on restart of itself, reset the host, or turn the host's power off. The ability to reset the host may be useful to allow certain host operating system configuration



changes to complete. The ability to turn the host's power off under software control may be useful in systems that do not have ACPI compatible BIOS.

NOTE

The GPIO pins used for ATX control must not be configured as user GPIO, and must be configured to their default drive mode in order for the ATX functions to work correctly. These settings are factory default, but may be changed by the user. Please see command [34 \(0x22\): Set or Set and Configure GPIO Pin \(Pg. 40\)](#).

Rebooting the CFA635 may be useful when testing the boot configuration. It may also be useful to re-enumerate the devices on the 1-Wire bus (CFA635+[WR-PWR-Y25](#) cable). To reboot the CFA635, send the following packet:

```
type = 0x05 = 510
valid data length is 3
data[0] = 8
data[1] = 18
data[2] = 99
```

NOTE

The CFA635 will return the acknowledge packet immediately, then reboot itself. The module will not respond to new command packets for up to 3 seconds..

To reset the host (CFA635+[WR-PWR-Y25](#) cable), assuming the host's reset line is connected to GPIO[3] as described in command [28 \(0x1C\): Set ATX Power Switch Functionality \(Pg. 37\)](#), send the following packet:

```
type = 0x05 = 510
valid data length is 3
data[0] = 12
data[1] = 28
data[2] = 97
```

NOTE

The CFA635 will return the acknowledge packet immediately, then reset the host. After resetting the host (~1.5 seconds), the module will reboot itself. The module will not respond to new command packets for up to 3 seconds (~4.5 seconds overall) after its reboot.

To turn the host's power off (CFA635+[WR-PWR-Y25](#) cable), assuming the host's power control line is connected to GPIO[2] as described in command [28 \(0x1C\): Set ATX Power Switch Functionality \(Pg. 37\)](#), send the following packet:

```
type = 0x05 = 510
valid data length is 3
data[0] = 3
data[1] = 11
data[2] = 95
```



NOTE

The CFA635 will return the acknowledge packet immediately, then power cycle the host. The power cycle length is dependent on the length of the power pulse (command [28 \(0x1C\): Set ATX Power Switch Functionality \(Pg. 37\)](#)). After power cycling the host, the module will reboot itself. The module will not respond to new command packets for up to 3 seconds after its reboot.

In any of the above cases, the return packet will be:

```
type = 0x40 | 0x05 = 0x45 = 6910  
data_length = 0
```

6 (0x06): Clear LCD Screen

Sets the contents of the LCD screen DDRAM to ' ' = 0x20 = 32 and moves the cursor to the left-most column of the top line.

```
type = 0x06 = 610  
valid data_length is 0
```

The return packet will be:

```
type = 0x40 | 0x06 = 0x46 = 7010  
data_length = 0
```

Clear LCD Screen is one of the items stored by the command [4 \(0x04\): Store Current State As Boot State \(Pg. 30\)](#).

7 (0x07): Deprecated (See command [31 \(0x1F\): Send Data to LCD \(Pg. 40\)](#))

8 (0x08): Deprecated (See command [31 \(0x1F\): Send Data to LCD \(Pg. 40\)](#))

9 (0x09): Set LCD Special Character Data

Sets the font definition for one of the special characters (CGRAM).

```
type = 0x09 = 910  
valid data_length is 9  
data[0] = index of special character that you would like to modify, 0-7 are valid  
data[1-8] = bitmap of the new font for this character
```

data[1-8] are the bitmap information for this character. Any value is valid between 0 and 63, the msb is at the left of the character cell of the row, and the lsb is at the right of the character cell.

data[1] is at the top of the cell.
data[8] is at the bottom of the cell.

Additionally, if you set bit 7 of any of the data bytes, the entire line will blink.

The return packet will be:

```
type = 0x40 | 0x09 = 0x49 = 7310  
data_length = 0
```



Set LCD Special Character Data is one of the items stored by the command [4 \(0x04\): Store Current State As Boot State \(Pg. 30\)](#).

10 (0x0A): Read 8 Bytes of LCD Memory

This command will return the contents of the LCD's DDRAM or CGRAM. This command is intended for debugging.

```
type = 0x0A = 1010
valid data_length is 1
data[0] = address code of desired data
```

data[0] is the address code native to the LCD controller:

```
0x40 ( 64) to 0x7F (127) for CGRAM
0x80 (128) to 0x93 (147) for DDRAM, line 0
0xA0 (160) to 0xB3 (179) for DDRAM, line 1
0xC0 (192) to 0xD3 (211) for DDRAM, line 2
0xE0 (224) to 0xF3 (243) for DDRAM, line 3
```

The return packet will be:

```
type = 0x40 | 0x0A = 0x4A = 7410
data_length = 9
```

data[0] of the return packet will be the address code.

data[1-8] of the return packet will be the data read from the LCD controller's memory.

11 (0x0B): Set LCD Cursor Position

This command allows the cursor to be placed at the desired location on the CFA635's LCD screen. If you want the cursor to be visible, you may also need to send a command [12 \(0x0C\): Set LCD Cursor Style \(Pg. 33\)](#).

```
type = 0x0B = 1110
valid data_length is 2
data[0] = column (0-19 valid)
data[1] = row (0-3 valid)
```

The return packet will be:

```
type = 0x40 | 0x0B = 0x4B = 7510
data_length = 0
```

Set LCD Cursor Position is one of the items stored by the command [4 \(0x04\): Store Current State As Boot State \(Pg. 30\)](#).

12 (0x0C): Set LCD Cursor Style

This command allows you to select among four hardware generated cursor options.

```
type = 0x0C = 1210
valid data_length is 1
data[0] = cursor style (0-4 valid)
0 = no cursor
1 = blinking block cursor
2 = underscore cursor
3 = blinking block plus underscore
4 = inverting, blinking block
```

The return packet will be:

```
type = 0x40 | 0x0C = 0x4C = 7610
data_length = 0
```

Set LCD Cursor Style is one of the items stored by the command [4 \(0x04\): Store Current State As Boot State \(Pg. 30\)](#).



13 (0x0D): Set LCD Contrast

This command sets the contrast or vertical viewing angle of the display.

```
type = 0x0D = 1310
valid data length is 1
data[0] = contrast setting (0-254 valid)
    0-65 = very light
    66 = light
    95 = about right
    125 = dark
    126-254 = very dark
```

The return packet will be:

```
type = 0x40 | 0x0D = 0x4D = 7710
data_length = 0
```

Set LCD Contrast is one of the items stored by the command [4 \(0x04\): Store Current State As Boot State \(Pg. 30\)](#).

14 (0x0E): Set LCD & Keypad Backlight

This command sets the brightness of the LCD and keypad backlights.

```
type = 0x0E = 1410
valid data length is 1
data[0] = backlight power setting (0-100 valid)
    0 = off
    1-99 = variable brightness
    100 = on
```

The return packet will be:

```
type = 0x40 | 0x0E = 0x4E = 7810
data_length = 0
```

Set LCD & Keypad Backlight is one of the items stored by the command [4 \(0x04\): Store Current State As Boot State \(Pg. 30\)](#).

15 (0x0F): Deprecated

16 (0x10): Reserved for Set Up Fan Reporting (SCAB required)

17 (0x11): Reserved for Set Fan Power (SCAB required)

18 (0x12): Reserved for Read DOW Device Information (SCAB required)

19 (0x13): Reserved for Set Up Temperature Reporting (SCAB required)

20 (0x14): Reserved for Arbitrary DOW Transaction (SCAB required)

21 (0x15): Deprecated



22 (0x16): Send Command Directly to the LCD Controller

The LCD controller on the CFA635 is Samsung a [S6A0073](#). Generally you won't need low-level access to the LCD controller but some arcane functions of the [S6A0073](#) are not exposed by the CFA635's command set. This command allows you to access the CFA635's LCD controller directly. Note: It is possible to corrupt the CFA635 display using this command.

```
type = 0x16 = 2210
data_length = 2
data[0]: location code
    0 = "Data" register
    1 = "Control" register, RE=0
    2 = "Control" register, RE=1
data[1]: data to write to the selected register
```

The return packet will be:

```
type = 0x40 | 0x16 = 0x56 = 8610
data_length = 0
```

23 (0x17): Configure Key Reporting

By default, the CFA635 reports any key event to the host. This command allows the key events to be enabled or disabled on an individual basis. The key events set to report are one of the items stored by the command [4 \(0x04\): Store Current State As Boot State \(Pg. 30\)](#).

```
#define KP_UP      0x01
#define KP_ENTER  0x02
#define KP_CANCEL 0x04
#define KP_LEFT   0x08
#define KP_RIGHT  0x10
#define KP_DOWN   0x20
```

```
type = 0x17 = 2310
data_length = 2
data[0]: press mask
data[1]: release mask
```

The return packet will be:

```
type = 0x40 | 0x17 = 0x57 = 8710
data_length = 0
```

Configure Key Reporting is one of the items stored by the command [4 \(0x04\): Store Current State As Boot State \(Pg. 30\)](#).

24 (0x18): Read Keypad, Polled Mode

In some situations, it may be convenient for the host to poll the CFA635 for key activity. This command allows the host to detect which keys are currently pressed, which keys have been pressed since the last poll, and which keys have been released since the last poll.

This command is independent of the key reporting masks set by command [23 \(0x17\): Configure Key Reporting \(Pg. 35\)](#). All keys are always visible to this command. Typically both masks of command 23 would be set to "0" if the host is reading the keypad in polled mode.



```
#define KP_UP      0x01
#define KP_ENTER  0x02
#define KP_CANCEL 0x04
#define KP_LEFT   0x08
#define KP_RIGHT  0x10
#define KP_DOWN   0x20
```

```
type = 0x18 = 2410
data_length = 0
```

The return packet will be:

```
type = 0x40 | 0x18 = 0x58 = 8810
data_length = 3
data[0] = bit mask showing the keys currently pressed
data[1] = bit mask showing the keys that have been pressed since
          the last poll
data[2] = bit mask showing the keys that have been released since
          the last poll
```

25 (0x19): Reserved for Set Fan Power Fail-Safe (SCAB required)

26 (0x1A): Reserved for Set Fan Tachometer Glitch Filter (SCAB required)

27 (0x1B): Reserved for Query Fan Power & Fail-Safe Mask (SCAB required)



28 (0x1C): Set ATX Power Switch Functionality

The combination of the CFA635+[WR-PWR-Y25](#) cable can be used to replace the function of the power and reset switches in a standard ATX-compatible system. The ATX Power Switch Functionality is one of the items stored by the command [4 \(0x04\): Store Current State As Boot State \(Pg. 30\)](#).

NOTE ON COMMAND 28: SET ATX POWER SWITCH FUNCTIONALITY

The GPIO pins used for ATX control must not be configured as user GPIO. The pins must be configured to their default drive mode in order for the ATX functions to work correctly.

These settings are factory default but may be changed by the user. Please see command [34 \(0x22\): Set or Set and Configure GPIO Pin \(Pg. 40\)](#). These settings must be saved as the boot state.

To ensure that GPIO[1] will operate correctly as ATX SENSE, user GPIO[1] must be configured as:

```
DDD = "011: 1=Resistive Pull Up, 0=Fast, Strong Drive Down".  
F = "0: Port unused for user GPIO."
```

This configuration can be assured by sending the following command:

```
command = 34  
length = 3  
data[0] = 1  
data[1] = 0  
data[2] = 3
```

To ensure that GPIO[2] will operate correctly as ATX POWER, user GPIO[2] must be configured as:

```
DDD = "010: Hi-Z, use for input".  
F = "0: Port unused for user GPIO."
```

This configuration can be assured by sending the following command:

```
command = 34  
length = 3  
data[0] = 2  
data[1] = 0  
data[2] = 2
```

To ensure that GPIO[3] will operate correctly as ATX RESET, user GPIO[3] must be configured as:

```
DDD = "010: Hi-Z, use for input".  
F = "0: Port unused for user GPIO."
```

This configuration can be assured by sending the following command:

```
command = 34  
length = 3  
data[0] = 3  
data[1] = 0  
data[2] = 2
```

These settings must be saved as the boot state.

The RESET (GPIO[3]) and POWER CONTROL (GPIO[2]) lines on the CFA635+[WR-PWR-Y25](#) cable are normally high-impedance. Electrically, they appear to be disconnected or floating. When the CFA635+[WR-PWR-Y25](#) cable asserts the RESET or POWER CONTROL lines, they are momentarily driven high or low (as determined by the RESET_INVERT and POWER_INVERT bits, detailed below). To end the power or reset pulse, the CFA635+[WR-PWR-Y25](#) cable changes the lines back to high-impedance.



FOUR FUNCTIONS ENABLED BY COMMAND 28

Function 1: KEYPAD_RESET

If POWER-ON SENSE (GPIO[1]) is high, holding the green check key for 4 seconds will pulse RESET (GPIO[3]) pin for 1 second. During the 1-second pulse, the CFA635 will show "RESET", and then the CFA635 will reset itself, showing its boot state as if it had just powered on. Once the pulse has finished, the CFA635 will not respond to any commands until after it has reset the host and itself.

Function 2: KEYPAD_POWER_ON

If POWER-ON SENSE (GPIO[1]) is low, pressing the green check key for 0.25 seconds will pulse POWER CONTROL (GPIO[2]) for the duration specified by in data[1] or the default of 1 second. During this time the CFA635 will show "POWER ON", then the CFA635 will reset itself.

Function 3: KEYPAD_POWER_OFF

If POWER-ON SENSE (GPIO[1]) is high, holding the red X key for 4 seconds will pulse POWER CONTROL (GPIO[2]) for the duration specified by in data[1] or the default of 1 second. If the user continues to hold the power key down, then the CFA635 will continue to drive the line for a maximum of 5 additional seconds. During this time the CFA635 will show "POWER OFF".

Function 4: LCD_OFF_IF_HOST_IS_OFF

If LCD_OFF_IF_HOST_IS_OFF is set, the CFA635 will blank its screen and turn off its backlight to simulate its power being off any time POWER-ON SENSE (GPIO[1]) is low. The CFA635 will still be active (since it is powered by V_{SB}), monitoring the keypad for a power-on keystroke. If +12v remains active (which would not be expected, since the host is "off"), the fans will remain on at their previous settings. Once POWER-ON SENSE (GPIO[1]) goes high, the CFA635 will reboot as if power had just been applied to it.

```
#define RESET_INVERT          0x02 //Reset pin drives high instead of low
#define POWER_INVERT        0x04 //Power pin drives high instead of low
#define LCD_OFF_IF_HOST_IS_OFF 0x10
#define KEYPAD_RESET        0x20
#define KEYPAD_POWER_ON    0x40
#define KEYPAD_POWER_OFF   0x80

type = 0x1C = 2810
data_length = 1 or 2
data[0]: bit mask of enabled functions
data[1]: (optional) length of power on & off pulses in 1/32 second
         1 = 1/32 sec
         2 = 1/16 sec
         16 = 1/2 sec
         255 = 8 sec
```

The return packet will be:

```
type = 0x40 | 0x1C = 0x5C = 9210
data_length = 0
```

29 (0x1D): Enable/Disable and Reset the Watchdog

Some high-availability systems use hardware watchdog timers to ensure that a software or hardware failure does not result in an extended system outage. Once the host system has booted, a system monitor program is started. The



system monitor program would enable the watchdog timer on the CFA635+[WR-PWR-Y25](#) cable. If the system monitor program fails to reset the watchdog timer, the CFA635+[WR-PWR-Y25](#) cable will reset the host system.

NOTE

The GPIO pins used for ATX control must not be configured as user GPIO. They must be configured to their default drive mode in order for the ATX functions to work correctly. These settings are factory default, but may be changed by the user. Please see the note under command [28 \(0x1C\): Set ATX Power Switch Functionality \(Pg. 37\)](#) or command [34 \(0x22\): Set or Set and Configure GPIO Pin \(Pg. 40\)](#).

```
type = 0x1D = 2910  
data_length = 1  
data[0] = enable/timeout
```

If timeout is 0, the watchdog is disabled.

If timeout is 1-255, then this command must be issued again within timeout seconds to avoid a watchdog reset.

To turn the watchdog off once it has been enabled, simply set timeout to 0.

If the command is not re-issued within timeout seconds, then the CFA635+[WR-PWR-Y25](#) cable will reset the host (see command 28 for details). Since the watchdog is off by default when the it powers up, the CFA635+[WR-PWR-Y25](#) cable will not issue another host reset until the host has once again enabled the watchdog.

The return packet will be:

```
type = 0x40 | 0x1D = 0x5D = 9310  
data_length = 0
```

30 (0x1E): Read Reporting & Status

This command can be used to verify the current items configured to report to the host, as well as some other miscellaneous status information.

```
type = 0x1E = 3010  
data_length = 0
```

The return packet will be:

```
type = 0x40 | 0x1E = 0x5E = 9410  
data_length = 15  
data[0] = Not Supported - fan reporting status (as set by command 16)  
data[1] = Not Supported - temperatures 1-8 reporting status (as set by command 19)  
data[2] = Not Supported - temperatures 9-15 reporting status (as set by command 19)  
data[3] = Not Supported - temperatures 16-23 reporting status (as set by command 19)  
data[4] = Not Supported - temperatures 24-32 reporting status (as set by command 19)  
data[5] = key presses (as set by command 23)  
data[6] = key releases (as set by command 23)  
data[7] = ATX Power Switch Functionality (as set by command 28)  
data[8] = current watchdog counter (as set by command 29)  
data[9] = Not Supported - fan RPM glitch delay[0] (as set by command 26)  
data[10] = Not Supported - fan RPM glitch delay[1] (as set by command 26)  
data[11] = Not Supported - fan RPM glitch delay[2] (as set by command 26)  
data[12] = Not Supported - fan RPM glitch delay[3] (as set by command 26)  
data[13] = contrast setting (as set by command 13)  
data[14] = backlight setting (as set by command 14)
```

Please Note: Previous and future firmware versions may return fewer or additional bytes.



31 (0x1F): Send Data to LCD

This command allows data to be placed at any position on the LCD.

```
type = 0x1F = 3110
data_length = 3 to 22
data[0]: col = x = 0 to 19
data[1]: row = y = 0 to 3
data[2-21]: text to place on the LCD, variable from 1 to 20 characters
```

The return packet will be:

```
type = 0x40 | 0x1F = 0x5F = 9510
data_length = 0
```

Send Data to LCD is one of the items stored by the command [4 \(0x04\): Store Current State As Boot State \(Pg. 30\)](#).

32 (0x20): Reserved for CFA631 Key Legends

33 (0x21): Set Baud Rate

This command will change the CFA635's baud rate. The CFA635 will send the acknowledge packet for this command and change its baud rate to the new value. The host should send the baud rate command, wait for a positive acknowledge from the CFA635 at the old baud rate, and then switch itself to the new baud rate. The baud rate must be saved by the command [4 \(0x04\): Store Current State As Boot State \(Pg. 30\)](#) if you want the CFA635 to power up at the new baud rate.

The factory default baud rate is 115200.

```
type = 0x21 = 3310
data_length = 0
data[0]: 0 = 19200 baud
         1 = 115200 baud
```

The return packet will be:

```
type = 0x40 | 0x21 = 0x61 = 9710
data_length = 0
```

34 (0x22): Set or Set and Configure GPIO Pin

The CFA635 has five pins for user-definable general purpose input / output (GPIO). These pins are shared with the DOW and ATX functions. Be careful when you configure the GPIO if you want to use the ATX or DOW at the same time.

The architecture of the CFA635 allows great flexibility in the configuration of the GPIO pins. They can be set as input or output. They can output constant high or low signals or a variable duty cycle 100 Hz PWM signal.

In output mode using the PWM (and a suitable current limiting resistor), an LED may be turned on or off and even dimmed under host software control. With suitable external circuitry, the GPIOs can also be used to drive external logic or power transistors.

The CFA635 continuously polls the GPIOs as inputs at 32 Hz. The present level can be queried by the host software at a lower rate. The CFA635 also keeps track of whether there were rising or falling edges since the last host query (subject to the resolution of the 32 Hz sampling). This means that the host is not forced to poll quickly in order to detect short events. The algorithm used by the CFA635 to read the inputs is inherently "bounce-free".

The GPIOs also have "pull-up" and "pull-down" modes. These modes can be useful when using the GPIO as an input connected to a switch since no external pull-up or pull-down resistor is needed. For instance, the GPIO can be set to pull



up. Then when a switch connected between the GPIO and ground is open, reading the GPIO will return a "1". When the switch is closed, the input will return a "0".

Pull-up/pull-down resistance values are approximately 5kΩ. Do not exceed current of 25 mA per GPIO.
 The GPIO configuration is one of the items stored by the command [4 \(0x04\): Store Current State As Boot State \(Pg. 30\)](#).

```

type: 0x22 = 3410
data_length:
  2 bytes to change value only
  3 bytes to change value and configure function and drive mode

data[0]: index of GPIO/GPO to modify
  0 = GPIO[0] = H1, Pin 11
  1 = GPIO[1] = H1, Pin 12 (default is ATX Host Power Sense)
  2 = GPIO[2] = H1, Pin 9 (default is ATX Host Power Control)
  3 = GPIO[3] = H1, Pin 10 (default is ATX Host Reset Control)
  4 = GPIO[4] = H1, Pin 13 (default is DOW I/O--has 1 KΩ hardware pull-up on SCAB)
  5 = GPO[ 5] = H2, Pin 15 = LED 3 (bottom) green die
  6 = GPO[ 6] = H2, Pin 13 = LED 3 (bottom) red die
  7 = GPO[ 7] = H2, Pin 11 = LED 2 green die
  8 = GPO[ 8] = H2, Pin 9 = LED 2 red die
  9 = GPO[ 9] = H2, Pin 7 = LED 1 green die
 10 = GPO[10] = H2, Pin 5 = LED 1 red die
 11 = GPO[11] = H2, Pin 3 = LED 0 (top) green die
 12 = GPO[12] = H2, Pin 1 = LED 0 (top) red die
 13-255 = reserved
  
```

Please note: Future versions of this command on future hardware models may accept additional values for data[0], which would control the state of future additional GPIO pins.

```

data[1] = Pin output state (actual behavior depends on drive mode):
  0 = Output set to low
  1-99 = Output duty cycle percentage (100 Hz nominal)
 100 = Output set to high
 101-254 = invalid
  
```

```

data[2] = Pin function select and drive mode (optional, 0-15 valid)
  
```

```

---- FDDD
||| | -- DDD = Drive Mode (based on output state of 1 or 0)
=====
000: 1=Fast, Strong Drive Up, 0=Resistive Pull Down
001: 1=Fast, Strong Drive Up, 0=Fast, Strong Drive Down
010: Hi-Z, use for input
011: 1=Resistive Pull Up, 0=Fast, Strong Drive Down
100: 1=Slow, Strong Drive Up, 0=Hi-Z
101: 1=Slow, Strong Drive Up, 0=Slow, Strong Drive Down
110: reserved, do not use
111: 1=Hi-Z, 0=Slow, Strong Drive Down

----- F = Function (only valid for GPIOs, index of 0-4)
Only meaningful for GPIOs (index 0-4). GPOs (index of 5-12) will ignore.
=====
0: Port unused for GPIO. It will take on the default
function such as ATX, DOW or unused. The user is
responsible for setting the drive to the correct
value in order for the default function to work
correctly.
1: Port used for GPIO under user control. The user is
responsible for setting the drive to the correct
value in order for the desired GPIO mode to work
correctly.
----- reserved, must be 0
  
```



The return packet will be:

```
type = 0x40 | 0x22 = 0x62 = 9810  
data_length = 0
```

35 (0x23): Read GPIO Pin Levels and Configuration State

Please see command [34 \(0x22\): Set or Set and Configure GPIO Pin \(Pg. 40\)](#) for details on the GPIO architecture.

```
type: 0x23 = 3510  
data_length: 1  
data[0]: index of GPIO to query  
0 = GPIO[0] = H1, Pin 11  
1 = GPIO[1] = H1, Pin 12 (default is ATX Host Power Sense)  
2 = GPIO[2] = H1, Pin 9 (default is ATX Host Power Control)  
3 = GPIO[3] = H1, Pin 10 (default is ATX Host Reset Control)  
4 = GPIO[4] = H1, Pin 13 (default is DOW I/O--always has 1 K $\Omega$  hardware pull-up on  
SCAB.)  
5 = GPO[ 5] = H2, Pin 15 = LED 3 (bottom) green die  
6 = GPO[ 6] = H2, Pin 13 = LED 3 (bottom) red die  
7 = GPO[ 7] = H2, Pin 11 = LED 2 green die  
8 = GPO[ 8] = H2, Pin 9 = LED 2 red die  
9 = GPO[ 9] = H2, Pin 7 = LED 1 green die  
10 = GPO[10] = H2, Pin 5 = LED 1 red die  
11 = GPO[11] = H2, Pin 3 = LED 0 (top) green die  
12 = GPO[12] = H2, Pin 1 = LED 0 (top) red die  
13-255 = reserved
```

Please note: Future versions of this command on future hardware models may accept additional values for data[0], which would return the status of future additional GPIO pins

The return packet will be:

```
type = 0x40 | 0x23 = 0x63 = 9910  
data_length = 4
```



CHARACTER GENERATOR ROM (CGROM)

To find the code for a given character, add the two numbers that are shown in bold for its row and column. For example, the superscript "9" is in the column labeled "128_d" and in the row labeled "9_d". Add 128 + 9 to get 137. When you send a byte with the value of 137 to the display, then a superscript "9" will be shown.

Character Generator ROM (CGROM) for CrystalFontz CFA-635

upper 4 bits lower 4 bits	0 _d 0000 ₂	16 _d 0001 ₂	32 _d 0010 ₂	48 _d 0011 ₂	64 _d 0100 ₂	80 _d 0101 ₂	96 _d 0110 ₂	112 _d 0111 ₂	128 _d 1000 ₂	144 _d 1001 ₂	160 _d 1010 ₂	176 _d 1011 ₂	192 _d 1100 ₂	208 _d 1101 ₂	224 _d 1110 ₂	240 _d 1111 ₂
0 _d 0000 ₂	CGRAM [0]															
1 _d 0001 ₂	CGRAM [1]															
2 _d 0010 ₂	CGRAM [2]															
3 _d 0011 ₂	CGRAM [3]															
4 _d 0100 ₂	CGRAM [4]															
5 _d 0101 ₂	CGRAM [5]															
6 _d 0110 ₂	CGRAM [6]															
7 _d 0111 ₂	CGRAM [7]															
8 _d 1000 ₂	CGRAM [0]															
9 _d 1001 ₂	CGRAM [1]															
10 _d 1010 ₂	CGRAM [2]															
11 _d 1011 ₂	CGRAM [3]															
12 _d 1100 ₂	CGRAM [4]															
13 _d 1101 ₂	CGRAM [5]															
14 _d 1110 ₂	CGRAM [6]															
15 _d 1111 ₂	CGRAM [7]															

Figure 9. Character Generator ROM (CGROM)



MODULE RELIABILITY AND LONGEVITY

MODULE RELIABILITY

ITEM	SPECIFICATION	
LCD portion (excluding Keypad, Indicator LEDs, and Backlights)	50,000 to 100,000 hours (typical)	
Keypad	1,000,000 keystrokes	
Bicolor LED Indicators	50,000 to 100,000 hours (typical)	
White LED Display and Blue LED Keypad Backlights <i>Note: We recommend that the backlight of white LED backlit modules be dimmed or turned off during periods of inactivity to conserve the white LED backlight lifetime.</i>	<i>Power-On Hours</i>	<i>% of Initial Brightness (New Module)</i>
	<10,000	>90%
	<50,000	>50%

MODULE LONGEVITY (EOL / REPLACEMENT POLICY)

CrystalFontz is committed to making all of our LCD modules available for as long as possible. Occasionally, a supplier discontinues a component, or a process used to make the module becomes obsolete, or the process moves to a more modern manufacturing line. In order to continue making the module, we will do our best to find an acceptable replacement part or process which will make the “replacement” fit, form, and function compatible with its predecessor.

We recognize that discontinuing a module may cause problems for some customers. However, rapidly changing technologies, component availability, or low customer order levels may force us to discontinue (“End of Life”, EOL) a module. For example, we must occasionally discontinue a module when a supplier discontinues a component or a manufacturing process becomes obsolete. When we discontinue a module, we will do our best to find an acceptable replacement module with the same fit, form, and function.

In most situations, you will not notice a difference when comparing a “fit, form, and function” replacement module to the discontinued module it replaces. However, sometimes a change in component or process for the replacement module results in a slight variation, perhaps an improvement, over the previous design.

Although the replacement module is still within the stated Data Sheet specifications and tolerances of the discontinued module, changes may require modification to your circuit and/or firmware. Possible changes include:

- *Backlight LEDs.* Brightness may be affected (perhaps the new LEDs have better efficiency) or the current they draw may change (new LEDs may have a different VF).
- *Controller.* A new controller may require minor changes in your code.
- *Component tolerances.* Module components have manufacturing tolerances. In extreme cases, the tolerance stack can change the visual or operating characteristics.

Please understand that we avoid changing a module whenever possible; we only discontinue a module if we have no other option. We post Part Change Notices (PCN) on the product’s website page as soon as possible. If interested, you can subscribe to future part change notifications.



CARE AND HANDLING PRECAUTIONS

For optimum operation of the CFA635-TMF-KL and to prolong its life, please follow the precautions described below.

ESD (ELECTRO-STATIC DISCHARGE) SPECIFICATIONS

The circuitry is industry standard CMOS logic and is susceptible to ESD damage. Please use industry standard antistatic precautions as you would for any other static sensitive devices such as expansion cards, motherboards, or integrated circuits.

DESIGN AND MOUNTING

- The exposed surface of the LCD “glass” is actually a polarizer laminated on top of the glass. To protect the polarizer from damage, the CFA635-TMF-KL ships with a protective film over the polarizer. Please peel off the protective film slowly. Peeling off the protective film abruptly may generate static electricity.
- The polarizer is made out of soft plastic and is easily scratched or damaged. When handling the module, avoid touching the polarizer. Finger oils are difficult to remove.
- To protect the soft plastic polarizer from damage, place a transparent plate (for example, acrylic, polycarbonate, or glass) in front of the CFA635-TMF-KL, leaving a small gap between the plate and the display surface. We recommend GE HP-92 Lexan, which is readily available and works well.
- Do not disassemble or modify the module.
- Do not modify the eight tabs of the metal bezel or make connections to them.
- Solder only to the I/O terminals. Use care when removing solder so you do not damage the PCB.
- Do not reverse polarity to the power supply connections. Reversing polarity will immediately ruin the module.

AVOID SHOCK, IMPACT, TORQUE, OR TENSION

- Do not expose the module to strong mechanical shock, impact, torque, or tension.
- Do not drop, toss, bend, or twist the module.
- Do not place weight or pressure on the module.

IF LCD PANEL BREAKS

- If the module is severely damaged and the LCD panel breaks, be careful to not get the liquid crystal fluid in your mouth or eyes.
- If the liquid crystal fluid touches your skin, clothes, or work surface, wash it off immediately using soap and plenty of water.

HOW TO CLEAN

- The polarizer (laminated to the glass) is soft plastic. The soft plastic is easily scratched or damaged. Damage will be especially obvious on a “negative” module (a module that appear dark when power is “off”). Be very careful when you clean the polarizer.
- Do not clean the polarizer with liquids. Do not wipe the polarizer with any type of cloth or swab (for example, Q-tips).
- Use the removable protective film to remove smudges (for example, fingerprints) and any foreign matter. If you no longer have the protective film, use standard transparent office tape (for example, Scotch® brand “Crystal Clear Tape”). If the polarizer is dusty, you may carefully blow it off with clean, dry, oil-free compressed air.



- CFA635-TMF-KL *without CrystalFontz overlay*: The exposed surface of the LCD “glass” is actually the front polarizer laminated to the glass. The polarizer is made out of a fairly soft plastic and is easily scratched or damaged. The polarizer will eventually become hazy if you do not take great care when cleaning it. Long contact with moisture (from condensation or cleaning) may permanently spot or stain the polarizer.

OPERATION

- Your circuit should be designed to protect the module from ESD and power supply transients.
- Observe the operating temperature limitations: a minimum of 0°C to a maximum of 50°C noncondensing with minimal fluctuation. Operation outside of these limits may shorten life and/or harm display.
 - At lower temperatures of this range, response time is delayed.
 - At higher temperatures of this range, display becomes dark. (You may need to adjust the contrast.)
- Operate away from dust, moisture, and direct sunlight.
- Adjust backlight brightness so the display is readable but not too bright. Dim or turn off the backlight during periods of inactivity to conserve the white LED backlight lifetime.

STORAGE AND RECYCLING

- Store in an ESD-approved container away from dust, moisture, and direct sunlight.
- Observe the storage temperature limitations: a minimum of -10°C minimum to +60°C non-condensing maximum with minimal fluctuations. Rapid temperature changes can cause moisture to form, resulting in permanent damage.
- Do not allow weight to be placed on the modules while they are in storage.
- Please recycle your outdated CrystalFontz modules at an approved facility.



APPENDIX A: SAMPLE CODE (INCLUDES ALGORITHMS TO CALCULATE THE CRC)

SAMPLE CODE

We encourage you to use the free sample code listed below. Please leave the original copyrights in the code.

- ❑ Windows compatible test/demonstration program and source.
<http://www.crystalfontz.com/product/635WinTest.html>
- ❑ Linux compatible command-line demonstration program with C source code. 8K.
http://www.crystalfontz.com/product/linux_cli_examples.html
- ❑ Supported by CrystalControl freeware.
<http://www.crystalfontz.com/product/CrystalControl2.html>

ALGORITHMS TO CALCULATE THE CRC

Below are eight sample algorithms that will calculate the CRC of a CFA635 packet. Some of the algorithms were contributed by forum members and originally written for the CFA631. The CRC used in the CFA635 is the same one that is used in IrDA, which came from PPP, which seems to be related to a CCITT (ref: Network Working Group Request for Comments: 1171) standard. At that point, the trail was getting a bit cold and diverged into several referenced articles and papers, dating back to 1983.

The polynomial used is $X^{16} + X^{12} + X^5 + X^0$ (0x8408)
The result is bit-wise inverted before being returned.

Algorithm 1: "C" Table Implementation

This algorithm is typically used on the host computer, where code space is not an issue.

```
//This code is from the IRDA LAP documentation, which appears to
//have been copied from PPP:
//
// http://irda.affiniscape.com/associations/2494/files/Specifications/
IrLAP11_Plus_Errata.zip
//
//I doubt that there are any worries about the legality of this code,
//searching for the first line of the table below, it appears that
//the code is already included in the linux 2.6 kernel "Driver for
//ST5481 USB ISDN modem". This is an "industry standard" algorithm
//and I do not think there are ANY issues with it at all.
typedef unsigned char ubyte;
typedef unsigned short word;
word get_crc(ubyte *bufptr, word len)
{
    //CRC lookup table to avoid bit-shifting loops.
    static const word crcLookupTable[256] =
        {0x00000, 0x01189, 0x02312, 0x0329B, 0x04624, 0x057AD, 0x06536, 0x074BF,
        0x08C48, 0x09DC1, 0x0AF5A, 0x0BED3, 0x0CA6C, 0x0DBE5, 0x0E97E, 0x0F8F7,
        0x01081, 0x00108, 0x03393, 0x0221A, 0x056A5, 0x0472C, 0x075B7, 0x0643E,
        0x09CC9, 0x08D40, 0x0BFDB, 0x0AE52, 0x0DAED, 0x0CB64, 0x0F9FF, 0x0E876,
        0x02102, 0x0308B, 0x00210, 0x01399, 0x06726, 0x076AF, 0x04434, 0x055BD,
        0x0AD4A, 0x0BCC3, 0x08E58, 0x09FD1, 0x0EB6E, 0x0FAE7, 0x0C87C, 0x0D9F5,
        0x03183, 0x0200A, 0x01291, 0x00318, 0x077A7, 0x0662E, 0x054B5, 0x0453C,
        0x0BDCB, 0x0AC42, 0x09ED9, 0x08F50, 0x0FBEF, 0x0EA66, 0x0D8FD, 0x0C974,
        0x04204, 0x0538D, 0x06116, 0x0709F, 0x00420, 0x015A9, 0x02732, 0x036BB,
        0x0CE4C, 0x0DFC5, 0x0ED5E, 0x0FCD7, 0x08868, 0x099E1, 0x0AB7A, 0x0BAF3,
        0x05285, 0x0430C, 0x07197, 0x0601E, 0x014A1, 0x00528, 0x037B3, 0x0263A,
```



```

0x0DECD,0x0CF44,0x0FDDF,0x0EC56,0x098E9,0x08960,0x0BBFB,0x0AA72,
0x06306,0x0728F,0x04014,0x0519D,0x02522,0x034AB,0x00630,0x017B9,
0x0EF4E,0x0FEC7,0x0CC5C,0x0DDD5,0x0A96A,0x0B8E3,0x08A78,0x09BF1,
0x07387,0x0620E,0x05095,0x0411C,0x035A3,0x0242A,0x016B1,0x00738,
0x0FFCF,0x0EE46,0x0DCDD,0x0CD54,0x0B9EB,0x0A862,0x09AF9,0x08B70,
0x08408,0x09581,0x0A71A,0x0B693,0x0C22C,0x0D3A5,0x0E13E,0x0F0B7,
0x00840,0x019C9,0x02B52,0x03ADB,0x04E64,0x05FED,0x06D76,0x07CFF,
0x09489,0x08500,0x0B79B,0x0A612,0x0D2AD,0x0C324,0x0F1BF,0x0E036,
0x018C1,0x00948,0x03BD3,0x02A5A,0x05EE5,0x04F6C,0x07DF7,0x06C7E,
0x0A50A,0x0B483,0x08618,0x09791,0x0E32E,0x0F2A7,0x0C03C,0x0D1B5,
0x02942,0x038CB,0x00A50,0x01BD9,0x06F66,0x07EEF,0x04C74,0x05DFD,
0x0B58B,0x0A402,0x09699,0x08710,0x0F3AF,0x0E226,0x0D0BD,0x0C134,
0x039C3,0x0284A,0x01AD1,0x00B58,0x07FE7,0x06E6E,0x05CF5,0x04D7C,
0x0C60C,0x0D785,0x0E51E,0x0F497,0x08028,0x091A1,0x0A33A,0x0B2B3,
0x04A44,0x05BCD,0x06956,0x078DF,0x00C60,0x01DE9,0x02F72,0x03EFB,
0x0D68D,0x0C704,0x0F59F,0x0E416,0x090A9,0x08120,0x0B3BB,0x0A232,
0x05AC5,0x04B4C,0x079D7,0x0685E,0x01CE1,0x00D68,0x03FF3,0x02E7A,
0x0E70E,0x0F687,0x0C41C,0x0D595,0x0A12A,0x0B0A3,0x08238,0x093B1,
0x06B46,0x07ACF,0x04854,0x059DD,0x02D62,0x03CEB,0x00E70,0x01FF9,
0x0F78F,0x0E606,0x0D49D,0x0C514,0x0B1AB,0x0A022,0x092B9,0x08330,
0x07BC7,0x06A4E,0x058D5,0x0495C,0x03DE3,0x02C6A,0x01EF1,0x00F78};

```

```

register word
newCrc;
newCrc=0xFFFF;
//This algorithm is based on the IrDA LAP example.
while(len--)
  newCrc = (newCrc >> 8) ^ crcLookupTable[(newCrc ^ *bufptr++) & 0xff];

//Make this crc match the one's complement that is sent in the packet.
return(~newCrc);
}

```

Algorithm 2: "C" Bit Shift Implementation

This algorithm was mainly written to avoid any possible legal issues about the source of the routine (at the request of the LCDproc group). This routine was "clean" coded from the definition of the CRC. It is ostensibly smaller than the table driven approach but will take longer to execute. This routine is offered under the GPL.

```

typedef unsigned char ubyte;
typedef unsigned short word;
word get_crc(ubyte *bufptr,word len)
{
  register unsigned int
  newCRC;
  //Put the current byte in here.
  ubyte
  data;
  int
  bit_count;
  //This seed makes the output of this shift based algorithm match
  //the table based algorithm. The center 16 bits of the 32-bit
  //"newCRC" are used for the CRC. The MSb of the lower byte is used
  //to see what bit was shifted out of the center 16 bit CRC
  //accumulator ("carry flag analog");
  newCRC=0x00F32100;
  while(len--)
  {
    //Get the next byte in the stream.
    data=*bufptr++;
    //Push this byte's bits through a software
    //implementation of a hardware shift & xor.
    for(bit_count=0;bit_count<=7;bit_count++)
    {
      //Shift the CRC accumulator
      newCRC>>=1;

```



```
//The new MSB of the CRC accumulator comes
//from the LSB of the current data byte.
if(data&0x01)
    newCRC|=0x00800000;

//If the low bit of the current CRC accumulator was set
//before the shift, then we need to XOR the accumulator
//with the polynomial (center 16 bits of 0x00840800)
if(newCRC&0x00000080)
    newCRC^=0x00840800;
//Shift the data byte to put the next bit of the stream
//into position 0.
data>>=1;
}
}

//All the data has been done. Do 16 more bits of 0 data.
for(bit_count=0;bit_count<=15;bit_count++)
{
    //Shift the CRC accumulator
    newCRC>>=1;

    //If the low bit of the current CRC accumulator was set
    //before the shift we need to XOR the accumulator with
    //0x00840800.
    if(newCRC&0x00000080)
        newCRC^=0x00840800;
}
//Return the center 16 bits, making this CRC match the one's
//complement that is sent in the packet.
return((~newCRC)>>8);
}
```



Algorithm 2B: "C" Improved Bit Shift Implementation

This is a simplified algorithm that implements the CRC.

```

unsigned short get_crc(unsigned char count,unsigned char *ptr)
{
  unsigned short
    crc; //Calculated CRC
  unsigned char
    i; //Loop count, bits in byte
  unsigned char
    data; //Current byte being shifted

  crc = 0xFFFF; // Preset to all 1's, prevent loss of leading zeros

  while(count--)
  {
    data = *ptr++;
    i = 8;
    do
    {
      if((crc ^ data) & 0x01)
      {
        crc >>= 1;
        crc ^= 0x8408;
      }
      else
        crc >>= 1;
      data >>= 1;
    } while(--i != 0);
  }
  return (~crc);
}

```

Algorithm 3: "PIC Assembly" Bit Shift Implementation

This routine was graciously donated by one of our customers.

```

;=====
; CrystalFontz CFA635 PIC CRC Calculation Example
;
; This example calculates the CRC for the hard coded example provided
; in the documentation.
;
; It uses "This is a test. " as input and calculates the proper CRC
; of 0x93FA.
;=====
#include "p16f877.inc"
;=====
; CRC16 equates and storage
;-----
accuml      equ    40h      ; BYTE - CRC result register high byte
accumh      equ    41h      ; BYTE - CRC result register high low byte
datareg     equ    42h      ; BYTE - data register for shift
j           equ    43h      ; BYTE - bit counter for CRC 16 routine
Zero        equ    44h      ; BYTE - storage for string memory read
index       equ    45h      ; BYTE - index for string memory read
savchr      equ    46h      ; BYTE - temp storage for CRC routine

```



```
;
seedlo      equ      021h      ; initial seed for CRC reg lo byte
seedhi      equ      0F3h      ; initial seed for CRC reg hi byte
;
polyL       equ      008h      ; polynomial low byte
polyH       equ      084h      ; polynomial high byte
;=====
; CRC Test Program
;-----
          org          0          ; reset vector = 0000H
;
          clrf         PCLATH     ; ensure upper bits of PC are cleared
          clrf         STATUS     ; ensure page bits are cleared
          goto        main       ; jump to start of program
;
; ISR Vector
;
          org          4          ; start of ISR
          goto        $          ; jump to ISR when coded
;
main      org          20          ; start of main program
          movlw       seedhi      ; setup initial CRC seed value.
          movwf       accumh      ; This must be done prior to
          movlw       seedlo      ; sending string to CRC routine.
          movwf       accuml      ;
          clrf        index       ; clear string read variables
;
main1     movlw       HIGH InputStr ; point to LCD test string
          movwf       PCLATH     ; latch into PCL
          movfw       index       ; get index
          call        InputStr   ; get character
          movwf       Zero       ; setup for terminator test
          movf        Zero,f      ; see if terminator
          btfsc       STATUS,Z    ; skip if not terminator
          goto        main2      ; else terminator reached, jump out of loop
          call        CRC16      ; calculate new crc
          call        SENDUART   ; send data to LCD
          incf        index,f     ; bump index
          goto        main1      ; loop
;
main2     movlw       00h         ; shift accumulator 16 more bits.
          call        CRC16      ; This must be done after sending
          movlw       00h         ; string to CRC routine.
          call        CRC16      ;
;
          comf        accumh,f    ; invert result
          comf        accuml,f   ;
;
          movfw       accuml      ; get CRC low byte
          call        SENDUART   ; send to LCD
          movfw       accumh      ; get CRC hi byte
          call        SENDUART   ; send to LCD
;
stop      goto        stop       ; word result of 0x93FA is in accumh/accuml
;=====
; calculate CRC of input byte
;-----
CRC16     movwf       savchr      ; save the input character
          movwf       datareg     ; load data register
          movlw       .8         ; setup number of bits to test
          movwf       j          ; save to incrementor
;
_loop     clr        c          ; clear carry for CRC register shift
          rrf         datareg,f   ; perform shift of data into CRC register
```



```

    rrf      accumh,f    ;
    rrf      accuml,f    ;
    btfss    STATUS,C    ; skip jump if if carry
    goto     _notset     ; otherwise goto next bit
    movlw    polyL       ; XOR poly mask with CRC register
    xorwf    accuml,F    ;
    movlw    polyH       ;
    xorwf    accumh,F    ;
_notset
    decfsz   j,F         ; decrement bit counter
    goto     _loop       ; loop if not complete
    movfw    savchr      ; restore the input character
    return   ; return to calling routine
;=====
; USER SUPPLIED Serial port transmit routine
;-----
SENDUART
    return   ; put serial xmit routine here
;=====
; test string storage
;-----
    org     0100h
;
InputStr
    addwf   PCL,f
    dt     7h,10h,"This is a test. ",0
;
;=====
end

```

Algorithm 4: “Visual Basic” Table Implementation

Visual BASIC has its own challenges as a language (such as initializing static arrays), and it is also challenging to use Visual BASIC to work with “binary” (arbitrary length character data possibly containing nulls—such as the “data” portion of the CFA635 packet) data. This routine was adapted from the C table implementation. The complete project can be found in our forums.

```

'This program is brutally blunt. Just like VB. No apologies.
'Written by CrystalFontz America, Inc. 2004 http://www.crystalfontz.com
'Free code, not copyright copyleft or anything else.
'Some visual basic concepts taken from:
'http://www.planet-source-code.com/vb/scripts/ShowCode.asp?txtCodeId=21434&lngWId=1
'most of the algorithm is from functions in 635\_WinTest:
'http://www.crystalfontz.com/product/635WinTest.html
'Full zip of the project is available in our forum:
'http://www.crystalfontz.com/forum/showthread.php?postid=9921#post9921

```

```

Private Type WORD
    Lo As Byte
    Hi As Byte
End Type

Private Type PACKET_STRUCT
    command As Byte
    data_length As Byte
    data(22) As Byte
    crc As WORD
End Type

Dim crcLookupTable(256) As WORD

Private Sub MSComm_OnComm()
'Leave this here
End Sub

```



```
'My understanding of visual basic is very limited--however it appears that there is no way
'to initialize an array of structures. Nice language. Fast processors, lots of memory, big
'disks, and we fill them up with this . . this . . this . . STUFF.
Sub Initialize_CRC_Lookup_Table()
  crcLookupTable(0).Lo = &H0
  crcLookupTable(0).Hi = &H0
  . . .
'For purposes of brevity in this data sheet, I have removed 251 entries of this table, the
'full source is available in our forum:
'http://www.crystalfontz.com/forum/showthread.php?postid=9921#post9921
  . . .
  crcLookupTable(255).Lo = &H78
  crcLookupTable(255).Hi = &HF
End Sub

'This function returns the CRC of the array at data for length positions
Private Function Get_CRC(ByRef data() As Byte, ByVal length As Integer) As WORD
  Dim Index As Integer
  Dim Table_Index As Integer
  Dim newCrc As WORD
  newCrc.Lo = &HFF
  newCrc.Hi = &HFF
  For Index = 0 To length - 1
    'exclusive-or the input byte with the low-order byte of the CRC register
    'to get an index into crcLookupTable
    Table_Index = newCrc.Lo Xor data(Index)
    'shift the CRC register eight bits to the right
    newCrc.Lo = newCrc.Hi
    newCrc.Hi = 0
    ' exclusive-or the CRC register with the contents of Table at Table_Index
    newCrc.Lo = newCrc.Lo Xor crcLookupTable(Table_Index).Lo
    newCrc.Hi = newCrc.Hi Xor crcLookupTable(Table_Index).Hi
  Next Index
  'Invert & return newCrc
  Get_CRC.Lo = newCrc.Lo Xor &HFF
  Get_CRC.Hi = newCrc.Hi Xor &HFF
End Function

Private Sub Send_Packet(ByRef packet As PACKET_STRUCT)
  Dim Index As Integer
  'Need to put the whole packet into a linear array
  'since you can't do type overrides. VB, gotta love it.
  Dim linear_array(26) As Byte
  linear_array(0) = packet.command
  linear_array(1) = packet.data_length
  For Index = 0 To packet.data_length - 1
    linear_array(Index + 2) = packet.data(Index)
  Next Index
  packet.crc = Get_CRC(linear_array, packet.data_length + 2)
  'Might as well move the CRC into the linear array too
  linear_array(packet.data_length + 2) = packet.crc.Lo
  linear_array(packet.data_length + 3) = packet.crc.Hi
  'Now a simple loop can dump it out the port.
  For Index = 0 To packet.data_length + 3
    MSComm.Output = Chr(linear_array(Index))
  Next Index
End Sub
```

Algorithm 5: “Java” Table Implementation

This [code was posted in our forum](#) by user “norm” as a working example of a Java CRC calculation.

```
public class CRC16 extends Object
{
  public static void main(String[] args)
  {
    byte[] data = new byte[2];
```



```

// hw - fw
data[0] = 0x01;
data[1] = 0x00;
System.out.println("hw -fw req");
System.out.println(Integer.toHexString(compute(data)));

// ping
data[0] = 0x00;
data[1] = 0x00;
System.out.println("ping");
System.out.println(Integer.toHexString(compute(data)));

// reboot
data[0] = 0x05;
data[1] = 0x00;
System.out.println("reboot");
System.out.println(Integer.toHexString(compute(data)));

// clear lcd
data[0] = 0x06;
data[1] = 0x00;
System.out.println("clear lcd");
System.out.println(Integer.toHexString(compute(data)));

// set line 1
data = new byte[18];
data[0] = 0x07;
data[1] = 0x10;
String text = "Test Test Test ";
byte[] textByte = text.getBytes();
for (int i=0; i < text.length(); i++) data[i+2] = textByte[i];
System.out.println("text 1");
System.out.println(Integer.toHexString(compute(data)));
}
private CRC16()
{
}
private static final int[] crcLookupTable =
{
0x00000,0x01189,0x02312,0x0329B,0x04624,0x057AD,0x06536,0x074BF,
0x08C48,0x09DC1,0x0AF5A,0x0BED3,0x0CA6C,0x0DBE5,0x0E97E,0x0F8F7,
0x01081,0x00108,0x03393,0x0221A,0x056A5,0x0472C,0x075B7,0x0643E,
0x09CC9,0x08D40,0x0BFDB,0x0AE52,0x0DAED,0x0CB64,0x0F9FF,0x0E876,
0x02102,0x0308B,0x00210,0x01399,0x06726,0x076AF,0x04434,0x055BD,
0x0AD4A,0x0BCC3,0x08E58,0x09FD1,0x0EB6E,0x0FAE7,0x0C87C,0x0D9F5,
0x03183,0x0200A,0x01291,0x00318,0x077A7,0x0662E,0x054B5,0x0453C,
0x0BDCB,0x0AC42,0x09ED9,0x08F50,0x0FBEF,0x0EA66,0x0D8FD,0x0C974,
0x04204,0x0538D,0x06116,0x0709F,0x00420,0x015A9,0x02732,0x036BB,
0x0CE4C,0x0DFC5,0x0ED5E,0x0FCD7,0x08868,0x099E1,0x0AB7A,0x0BAF3,
0x05285,0x0430C,0x07197,0x0601E,0x014A1,0x00528,0x037B3,0x0263A,
0x0DECD,0x0CF44,0x0FDDF,0x0EC56,0x098E9,0x08960,0x0BBFB,0x0AA72,
0x06306,0x0728F,0x04014,0x0519D,0x02522,0x034AB,0x00630,0x017B9,
0x0EF4E,0x0FEC7,0x0CC5C,0x0DDD5,0x0A96A,0x0B8E3,0x08A78,0x09BF1,
0x07387,0x0620E,0x05095,0x0411C,0x035A3,0x0242A,0x016B1,0x00738,
0x0FFCF,0x0EE46,0x0DCDD,0x0CD54,0x0B9EB,0x0A862,0x09AF9,0x08B70,
0x08408,0x09581,0x0A71A,0x0B693,0x0C22C,0x0D3A5,0x0E13E,0x0F0B7,
0x00840,0x019C9,0x02B52,0x03ADB,0x04E64,0x05FED,0x06D76,0x07CFF,
0x09489,0x08500,0x0B79B,0x0A612,0x0D2AD,0x0C324,0x0F1BF,0x0E036,
0x018C1,0x00948,0x03BD3,0x02A5A,0x05EE5,0x04F6C,0x07DF7,0x06C7E,
0x0A50A,0x0B483,0x08618,0x09791,0x0E32E,0x0F2A7,0x0C03C,0x0D1B5,
0x02942,0x038CB,0x00A50,0x01BD9,0x06F66,0x07EEF,0x04C74,0x05DFD,
0x0B58B,0x0A402,0x09699,0x08710,0x0F3AF,0x0E226,0x0D0BD,0x0C134,
0x039C3,0x0284A,0x01AD1,0x00B58,0x07FE7,0x06E6E,0x05CF5,0x04D7C,

```



```

0x0C60C, 0x0D785, 0x0E51E, 0x0F497, 0x08028, 0x091A1, 0x0A33A, 0x0B2B3,
0x04A44, 0x05BCD, 0x06956, 0x078DF, 0x00C60, 0x01DE9, 0x02F72, 0x03EFB,
0x0D68D, 0x0C704, 0x0F59F, 0x0E416, 0x090A9, 0x08120, 0x0B3BB, 0x0A232,
0x05AC5, 0x04B4C, 0x079D7, 0x0685E, 0x01CE1, 0x00D68, 0x03FF3, 0x02E7A,
0x0E70E, 0x0F687, 0x0C41C, 0x0D595, 0x0A12A, 0x0B0A3, 0x08238, 0x093B1,
0x06B46, 0x07ACF, 0x04854, 0x059DD, 0x02D62, 0x03CEB, 0x00E70, 0x01FF9,
0x0F78F, 0x0E606, 0x0D49D, 0x0C514, 0x0B1AB, 0x0A022, 0x092B9, 0x08330,
0x07BC7, 0x06A4E, 0x058D5, 0x0495C, 0x03DE3, 0x02C6A, 0x01EF1, 0x00F78
};
public static int compute(byte[] data)
{
  int newCrc = 0xFFFF;
  for (int i = 0; i < data.length; i++ )
  {
    int lookup = crcLookupTable[(newCrc ^ data[i]) & 0xFF];
    newCrc = (newCrc >> 8) ^ lookup;
  }
  return(~newCrc);
}
}

```

Algorithm 6: “Perl” Table Implementation

This code was translated from the C version by one of our customers.

```

#!/usr/bin/perl

use strict;

my @CRC_LOOKUP =
(0x00000, 0x01189, 0x02312, 0x0329B, 0x04624, 0x057AD, 0x06536, 0x074BF,
0x08C48, 0x09DC1, 0x0AF5A, 0x0BED3, 0x0CA6C, 0x0DBE5, 0x0E97E, 0x0F8F7,
0x01081, 0x00108, 0x03393, 0x0221A, 0x056A5, 0x0472C, 0x075B7, 0x0643E,
0x09CC9, 0x08D40, 0x0BFDB, 0x0AE52, 0x0DAED, 0x0CB64, 0x0F9FF, 0x0E876,
0x02102, 0x0308B, 0x00210, 0x01399, 0x06726, 0x076AF, 0x04434, 0x055BD,
0x0AD4A, 0x0BCC3, 0x08E58, 0x09FD1, 0x0EB6E, 0x0FAE7, 0x0C87C, 0x0D9F5,
0x03183, 0x0200A, 0x01291, 0x00318, 0x077A7, 0x0662E, 0x054B5, 0x0453C,
0x0BDCB, 0x0AC42, 0x09ED9, 0x08F50, 0x0FBEF, 0x0EA66, 0x0D8FD, 0x0C974,
0x04204, 0x0538D, 0x06116, 0x0709F, 0x00420, 0x015A9, 0x02732, 0x036BB,
0x0CE4C, 0x0DFC5, 0x0ED5E, 0x0FCD7, 0x08868, 0x099E1, 0x0AB7A, 0x0BAF3,
0x05285, 0x0430C, 0x07197, 0x0601E, 0x014A1, 0x00528, 0x037B3, 0x0263A,
0x0DECD, 0x0CF44, 0x0FDDF, 0x0EC56, 0x098E9, 0x08960, 0x0BBFB, 0x0AA72,
0x06306, 0x0728F, 0x04014, 0x0519D, 0x02522, 0x034AB, 0x00630, 0x017B9,
0x0EF4E, 0x0FEC7, 0x0CC5C, 0x0DDD5, 0x0A96A, 0x0B8E3, 0x08A78, 0x09BF1,
0x07387, 0x0620E, 0x05095, 0x0411C, 0x035A3, 0x0242A, 0x016B1, 0x00738,
0x0FFCF, 0x0EE46, 0x0DCDD, 0x0CD54, 0x0B9EB, 0x0A862, 0x09AF9, 0x08B70,
0x08408, 0x09581, 0x0A71A, 0x0B693, 0x0C22C, 0x0D3A5, 0x0E13E, 0x0F0B7,
0x00840, 0x019C9, 0x02B52, 0x03ADB, 0x04E64, 0x05FED, 0x06D76, 0x07CFF,
0x09489, 0x08500, 0x0B79B, 0x0A612, 0x0D2AD, 0x0C324, 0x0F1BF, 0x0E036,
0x018C1, 0x00948, 0x03BD3, 0x02A5A, 0x05EE5, 0x04F6C, 0x07DF7, 0x06C7E,
0x0A50A, 0x0B483, 0x08618, 0x09791, 0x0E32E, 0x0F2A7, 0x0C03C, 0x0D1B5,
0x02942, 0x038CB, 0x00A50, 0x01BD9, 0x06F66, 0x07EEF, 0x04C74, 0x05DFD,
0x0B58B, 0x0A402, 0x09699, 0x08710, 0x0F3AF, 0x0E226, 0x0D0BD, 0x0C134,
0x039C3, 0x0284A, 0x01AD1, 0x00B58, 0x07FE7, 0x06E6E, 0x05CF5, 0x04D7C,
0x0C60C, 0x0D785, 0x0E51E, 0x0F497, 0x08028, 0x091A1, 0x0A33A, 0x0B2B3,
0x04A44, 0x05BCD, 0x06956, 0x078DF, 0x00C60, 0x01DE9, 0x02F72, 0x03EFB,
0x0D68D, 0x0C704, 0x0F59F, 0x0E416, 0x090A9, 0x08120, 0x0B3BB, 0x0A232,
0x05AC5, 0x04B4C, 0x079D7, 0x0685E, 0x01CE1, 0x00D68, 0x03FF3, 0x02E7A,
0x0E70E, 0x0F687, 0x0C41C, 0x0D595, 0x0A12A, 0x0B0A3, 0x08238, 0x093B1,
0x06B46, 0x07ACF, 0x04854, 0x059DD, 0x02D62, 0x03CEB, 0x00E70, 0x01FF9,
0x0F78F, 0x0E606, 0x0D49D, 0x0C514, 0x0B1AB, 0x0A022, 0x092B9, 0x08330,
0x07BC7, 0x06A4E, 0x058D5, 0x0495C, 0x03DE3, 0x02C6A, 0x01EF1, 0x00F78);

# our test packet read from an enter key press over the serial line:
# type = 80          (key press)
# data_length = 1   (1 byte of data)
# data = 5

```



```

my $type = '80';
my $length = '01';
my $data = '05';

my $packet = chr(hex $type) .chr(hex $length) .chr(hex $data);

my $valid_crc = '5584' ;

print "A CRC of Packet ($packet) Should Equal ($valid_crc)\n";

my $crc = 0xFFFF ;

printf("%x\n", $crc);

foreach my $char (split //, $packet)
{
  # newCrc = (newCrc >> 8) ^ crcLookupTable[(newCrc ^ *bufptr++) & 0xff];
  # & is bitwise AND
  # ^ is bitwise XOR
  # >> bitwise shift right
  $crc = ($crc >> 8) ^ $CRC_LOOKUP[( $crc ^ ord($char) ) & 0xFF] ;
  # print out the running crc at each byte
  printf("%x\n", $crc);
}

# get the complement
$crc = ~$crc ;
$crc = ($crc & 0xFFFF) ;

# print out the crc in hex
printf("%x\n", $crc);

```

Algorithm 7: For PIC18F8722 or PIC18F2685

This code was written for the CFA635 by customer Virgil Stamps of ATOM Instrument Corporation.

```

; CRC Algorithm for CrystalFontz CFA-635 display (DB535)
; This code written for PIC18F8722 or PIC18F2685
;
; Your main focus here should be the ComputeCRC2 and
; CRC16_ routines
;
;=====
ComputeCRC2:
    movlb    RAM8
    movwf   dsplyLPCNT    ;w has the byte count
nxt1_dsply:
    movf    POSTINC1,w
    call   CRC16_
    decfsz dsplyLPCNT
    goto   nxt1_dsply
    movlw  .0                ; shift accumulator 16 more bits
    call   CRC16_
    movlw  .0
    call   CRC16_
    comf   dsplyCRC,F        ; invert result
    comf   dsplyCRC+1,F
    return
;=====
CRC16_ movwf:
    dsplyCRCDATA            ; w has byte to crc
    movlw  .8
    movwf  dsplyCRCCOUNT
_cloop:

```



```
        bcf     STATUS,C           ; clear carry for CRC register shift
        rrcf   dsplyCRCDData,f    ; perform shift of data into CRC
                                   ;register

        rrcf   dsplyCRC,F
        rrcf   dsplyCRC+1,F
        btfss  STATUS,C           ; skip jump if carry
        goto   _notset            ; otherwise goto next bit
        movlw  0x84
        xorwf  dsplyCRC,F
        movlw  0x08                ; XOR poly mask with CRC register
        xorwf  dsplyCRC+1,F

_notset:
        decfsz dsplyCRCCount,F    ; decrement bit counter
        bra   _cloop              ; loop if not complete
        return

;=====
; example to clear screen
dsplyFSR1_TEMP equ 0x83A        ; 16-bit save for FSR1 for display
                                   ; message handler
dsplyCRC equ 0x83C              ; 16-bit CRC (H/L)
dsplyLPCNT equ 0x83E           ; 8-bit save for display message
                                   ; length - CRC
dsplyCRCDData equ 0x83F        ; 8-bit CRC data for display use
dsplyCRCCount equ 0x840        ; 8-bit CRC count for display use
SendCount equ 0x841            ; 8-bit byte count for sending to
                                   ; display
RXBUF2 equ 0x8C0                ; 32-byte receive buffer for
                                   ; Display
TXBUF2 equ 0x8E0                ; 32-byte transmit buffer for
                                   ; Display

;-----
ClearScreen:
        movlb  RAM8
        movlw  .0
        movwf  SendCount
        movlw  0xF3
        movwf  dsplyCRC          ; seed ho for CRC calculation
        movlw  0x21
        movwf  dsplyCRC+1        ; seen lo for CRC calculation
        call   ClaimFSR1
        movlw  0x06
        movwf  TXBUF2
        LFSR   FSR1,TXBUF2
        movf   SendCount,w
        movwf  TXBUF2+1          ; message data length
        call   BMD1
        goto   SendMsg

;=====
; send message via interrupt routine. The code is made complex due
; to the limited FSR registers and extended memory space used
;
; example of sending a string to column 0, row 0
;-----
SignOnL1:
        call   ClaimFSR1
        lfsr   FSR1,TXBUF2+4     ; set data string position
        SHOW   COR0,BusName      ; move string to TXBUF2
        movlw  .2
        addwf  SendCount
        movff  SendCount,TXBUF2+1 ; insert message data length

        call   BuildMsgDSPLY
        call   SendMsg
        return

;=====
; BuildMsgDSPLY used to send a string to LCD
;-----
BuildMsgDSPLY:
```



```
    movlw    0xF3
    movwf    dsplyCRC        ; seed hi for CRC calculation
    movlw    0x21
    movwf    dsplyCRC+1     ; seed lo for CRC calculation
    LFSR     FSR1, TXBUF2   ; point at transmit buffer
    movlw    0x1F           ; command to send data to LCD
    movwf    TXBUF2        ; insert command byte from us to
                                ; CFA-635

    BMD1     movlw .2
    ddwf     SendCount,w    ; + overhead
    call     ComputeCRC2   ; compute CRC of transmit message
    movf     dsplyCRC+1,w
    movwf    POSTINC1      ; append CRC byte
    movf     dsplyCRC,w
    movwf    POSTINC1      ; append CRC byte
    return

;=====
SendMsg:
    call     ReleaseFSR1
    LFSR     FSR0, TXBUF2
    movff    FSR0H, irptFSR0
    movff    FSR0L, irptFSR0+1
                                ; save interrupt use of FSR0
    movff    SendCount, TXBUSY2
    bsf     PIE2, TX2IE
                                ; set transmit interrupt enable
                                ; (bit 4)

    return

;=====
; macro to move string to transmit buffer
SHOW macro src, stringname
    call     src
    MOVLFS  upper stringname, TBLPTRU
    MOVLFS  high stringname, TBLPTRH
    MOVLFS  low stringname, TBLPTRL
    call     MOVE_STR
endm

;=====
MOVE_STR:
    tblrd   *+
    movf    TABLAT,w
    bz     ms1b
    movwf   POSTINC1
    incf    SendCount
    goto   MOVE_STR

ms1b:
    return

;=====
```



APPENDIX B: QUALITY ASSURANCE STANDARDS

INSPECTION CONDITIONS

- Environment
 - Temperature: 25±5°C
 - Humidity: 30~85% RH
- For visual inspection of active display area
 - Source lighting: two 20 watt or one 40 watt fluorescent light
 - Display adjusted for best contrast
 - Viewing distance: 30±5 cm (about 12 inches)
 - Viewing angle: inspect at 45° angle of normal line right and left, top and bottom

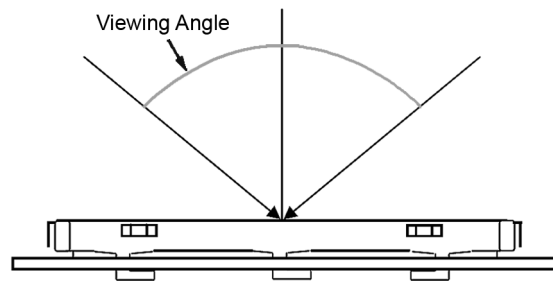

COLOR DEFINITIONS

We try to describe the appearance of our modules as accurately as possible. For the photos, we adjust for optimal appearance. Actual display appearance may vary due to (1) different operating conditions, (2) small variations of component tolerances, (3) inaccuracies of our camera, (4) color interpretation of the photos on your monitor, and/or (5) personal differences in the perception of color.

DEFINITION OF ACTIVE AREA AND VIEWING AREA

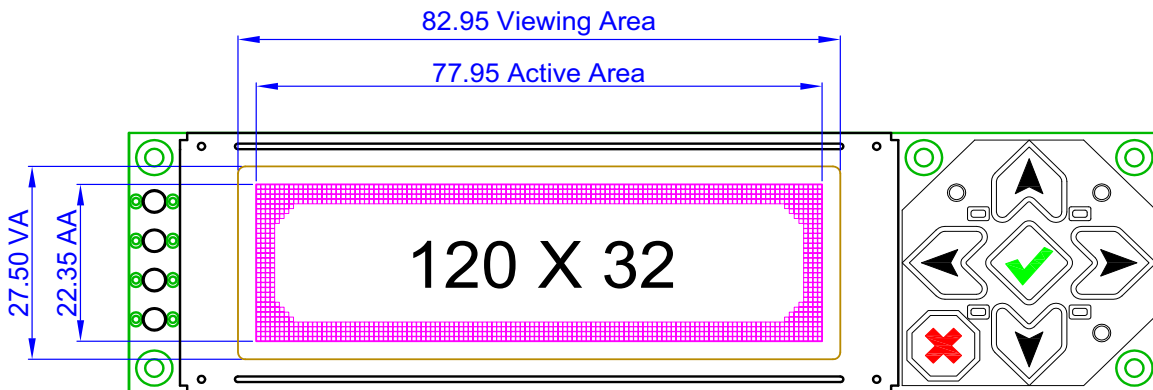



ACCEPTANCE SAMPLING

DEFECT TYPE	AQL*
Major	≤.65%
Minor	<1.0%
* Acceptable Quality Level: maximum allowable error rate or variation from standard	

DEFECTS CLASSIFICATION

Defects are defined as:

- A *major defect* is a defect that substantially reduces usability of unit for its intended purpose.
- A *minor defect*: is a defect that is unlikely to reduce usability for its intended purpose.

ACCEPTANCE STANDARDS

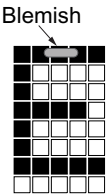
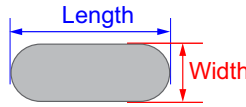
#	DEFECT TYPE	CRITERIA		MAJOR / MINOR	
1	Electrical defects	1. No display, display malfunctions, or shorted segments. 2. Current consumption exceeds specifications.		Major	
2	Viewing area defect	Viewing area does not meet specifications. (See Inspection Conditions (Pg. 60) .)		Major	
3	Contrast adjustment defect	Contrast adjustment fails or malfunctions.		Major	
4	Blemishes or foreign matter on display segments		<i>Defect Size</i> ≤0.3 mm	<i>Acceptable Qty</i> 3	Minor
			≤2 defects within 10 mm of each other		
5	Blemishes or foreign matter outside of display segments	Defect Size = (Width + Length)/2 	<i>Defect Size</i> ≤0.15 mm	<i>Acceptable Qty</i> Ignore	Minor
			0.15 to 0.20 mm	3	
			0.20 to 0.25 mm	2	
			0.25 to 0.30 mm	1	

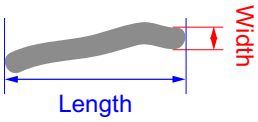
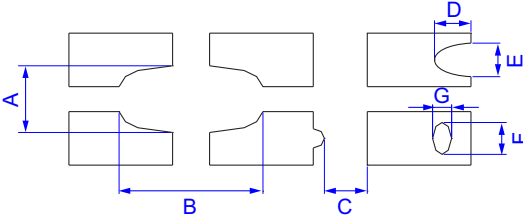

#	DEFECT TYPE	CRITERIA			MAJOR / MINOR
6	Dark lines or scratches in display area 	<i>Defect Width</i>	<i>Defect Length</i>	<i>Acceptable Qty</i>	Minor
		≤0.03 mm	≤3.0 mm	3	
		0.03 to 0.05	≤2.0 mm	2	
		0.05 to 0.08	≤2.0 mm	1	
		0.08 to 0.10	≤3.0 mm	0	
		≥0.10	>3.0 mm	0	
7	Bubbles between polarizer film and glass	<i>Defect Size</i>	<i>Acceptable Qty</i>	Minor	
		≤0.2 mm	Ignore		
		0.20 to 0.40 mm	3		
		0.40 to 0.60 mm	2		
		≥0.60 mm	0		
8	Display pattern defect 	<i>Dot Size</i>	<i>Acceptable Qty</i>	Minor	
		$((A+B)/2) \leq 0.2$ mm	≤3 total defects ≤2 pinholes per digit		
		C > 0 mm			
		$((D+E)/2) \leq 0.25$ mm			
		$((F+G)/2) \leq 0.25$ mm			
		9	Backlight defects	1. Oxidation or contamination on connectors.* 2. Wrong parts, missing parts, or parts not in specification.* 3. Jumpers set incorrectly. 4. Solder (if any) on bezel, LED pad, zebra pad, or screw hole pad is not smooth. *Minor if display functions correctly. Major if the display fails.	
10	PCB defects	1. Oxidation or contamination on connectors.* 2. Wrong parts, missing parts, or parts not in specification.* 3. Jumpers set incorrectly. 4. Solder (if any) on bezel, LED pad, zebra pad, or screw hole pad is not smooth. *Minor if display functions correctly. Major if the display fails.			Minor



#	DEFECT TYPE	CRITERIA	MAJOR / MINOR
11	Soldering defects	1. Unmelted solder paste. 2. Cold solder joints, missing solder connections, or oxidation.* 3. Solder bridges causing short circuits.* 4. Residue or solder balls. 5. Solder flux is black or brown. <i>*Minor if display functions correctly. Major if the display fails.</i>	Minor