

Crystalfontz America, Inc.

SPECIFICATION

CUSTOMER : _____

MODULE NO.: CFAG128128B-TFH-VZ

SALES BY	APPROVED BY	CHECKED BY	PREPARED BY
ISSUED DATE:			

Crystalfontz America, Inc.

12412 East Saltese Avenue
Spokane Valley, WA 99216-0357

Phone: (888) 206-9720

Fax: (509) 892-1203

Email: techinfo@crystalfontz.com

URL: www.crystalfontz.com

Contents

1. Module Classification Information
2. Precautions in use of LCD Modules
3. General Specification
4. Absolute Maximum Ratings
5. Electrical Characteristics
6. Optical Characteristics
7. Power Supply for LCD Module and Contrast Adjust
8. Contour Drawing & Block Diagram
9. Interface Pin Function
10. Display control instruction
11. Timing Characteristics
12. Reliability
13. Backlight Information
14. Material List of Components for RoHS

1. Module Classification Information

CFA G 1 2 8 1 2 8 B T F H VN
 ① ② ③ ④ ⑤ ⑥ ⑦ ⑧

①	Brand: CRYSTALFONTZ AMERICA, INC	
②	Display Type: H→Character Type, G→Graphic Type	
③	Displays Logical Dimensions: 128 pixels by 128 pixels	
④	Model PCB Variant: B	
⑤	Backlight Type:	N→Without backlight B→EL, Blue green D→EL, Green W→EL, White F→CCFL, White Y→LED, Yellow Green T→ LED, White A→LED, Amber R→LED, Red O→LED, Orange G→LED, Green
⑥	LCD Mode:	B→TN Positive, Gray T→FSTN Negative N→TN Negative, G→STN Positive, Gray Y→STN Positive, Yellow Green M→STN Negative, Blue F→FSTN Positive
⑦	LCD Polarizer Type/ Temperature range/ View direction	A→Reflective, N.T, 6:00 H→Transflective, W.T,6:00 D→Reflective, N.T, 12:00 K→Transflective, W.T,12:00 G→Reflective, W. T, 6:00 C→Transmissive, N.T,6:00 J→Reflective, W. T, 12:00 F→Transmissive, N.T,12:00 B→Transflective, N.T,6:00 I→Transmissive, W. T, 6:00 E→Transflective, N.T,12:00 L→Transmissive, W.T,12:00
⑧	Special Code	V→Built in Negative voltage generator;

2. Precautions in use of LCD Modules

- (1) Avoid applying excessive shocks to the module or making any alterations or modifications to it.
- (2) Don't make extra holes on the printed circuit board, modify its shape or change the components of LCD module.
- (3) Don't disassemble the LCM.
- (4) Don't operate it above the absolute maximum rating.
- (5) Don't drop, bend or twist LCM.
- (6) Soldering: only to the I/O terminals.
- (7) Storage: please storage in anti-static electricity container and clean environment.

3. General Specification

ITEM	STANDARD VALUE	UNIT
Number of Dots	128 ×128	
Module dimension	72.5×69.9×10.0(MAX)	mm
View area	50.0×49.0	mm
Active area	44.77×44.77	mm
Dot size	0.32×0.32	mm
Dot pitch	0.35×0.35	mm
LCD type	FSTN Positive , Transflective	
Duty	1/128	
View direction	6 o'clock	
Backlight	LED, WHITE	

4. Absolute Maximum Ratings

ITEM	SYMBOL	MIN.	TYP.	MAX.	UNIT
Operating Temperature	T_{OP}	-20	□	+70	°C
Storage Temperature	T_{ST}	-30	□	+80	°C
Input Voltage	V_I	V_{SS}	□	V_{DD}	V
Supply Voltage For Logic	$V_{CC}-V_{SS}$	-0.3	□	+7	V
Supply Voltage For LCD	$V_{CC}-V_{EE}$	0	□	28	V

5. Electrical Characteristics

ITEM	SYMBOL	CONDITIO N	MIN.	TYP.	MAX.	UNIT
Supply Voltage For Logic	$V_{DD}-V_{SS}$	□	4.75	5.0	5.25	V
Supply Voltage For LCD	$V_{DD}-V_0$	Ta=-20°C		□	18.2	V
		Ta=25°C	□	16.3	□	V
		Ta=70°C	14.9	□		V
Input High Volt.	V_{IH}	□	2.2	□	V_{DD}	V
Input Low Volt.	V_{IL}	□	0	□	0.8	V
Output High Volt.	V_{OH}	□	2.4	□	V_{DD}	V
Output Low Volt.	V_{OL}	□	0	□	0.4	V
Supply Current	I_{DD}	$V_{DD}=5V$	18	25	30	mA

6. Optical Characteristics

Item	Symbol	Condition	Min	Typ	Max	Unit
View Angle	(V) θ	$CR \geq 2$	20	\square	40	deg
	(H) ϕ	$CR \geq 2$	-30	\square	30	deg
Contrast Ratio	CR	\square	\square	3	\square	\square
Response Time	T rise	\square	\square	200	300	ms
	T fall	\square	\square	200	300	ms

6.1 Definitions

View Angles

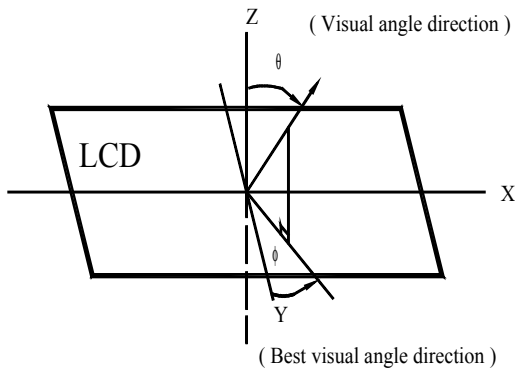

Contrast Ratio

$$CR = \frac{\text{Brightness at selected state (BS)}}{\text{Brightness at non-selected state (Bns)}}$$

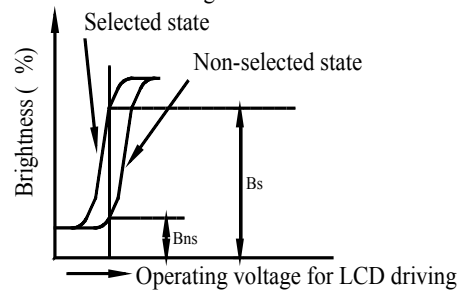

Response Time

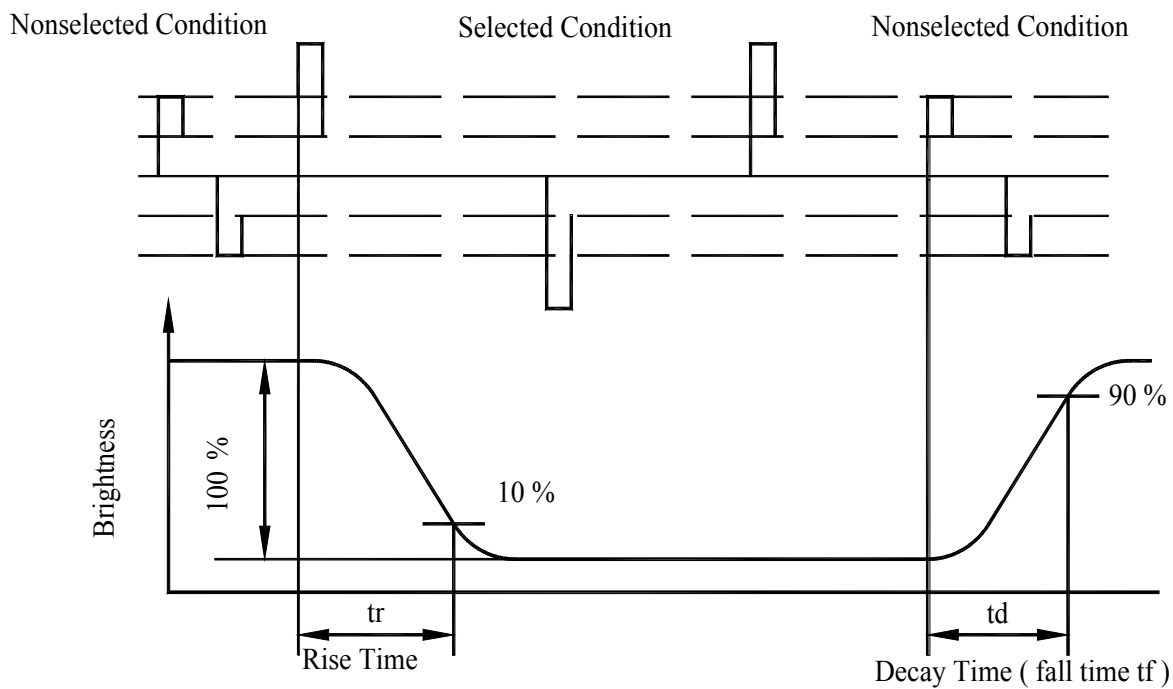

7. Power Supply for LCD Module and Contrast Adjust

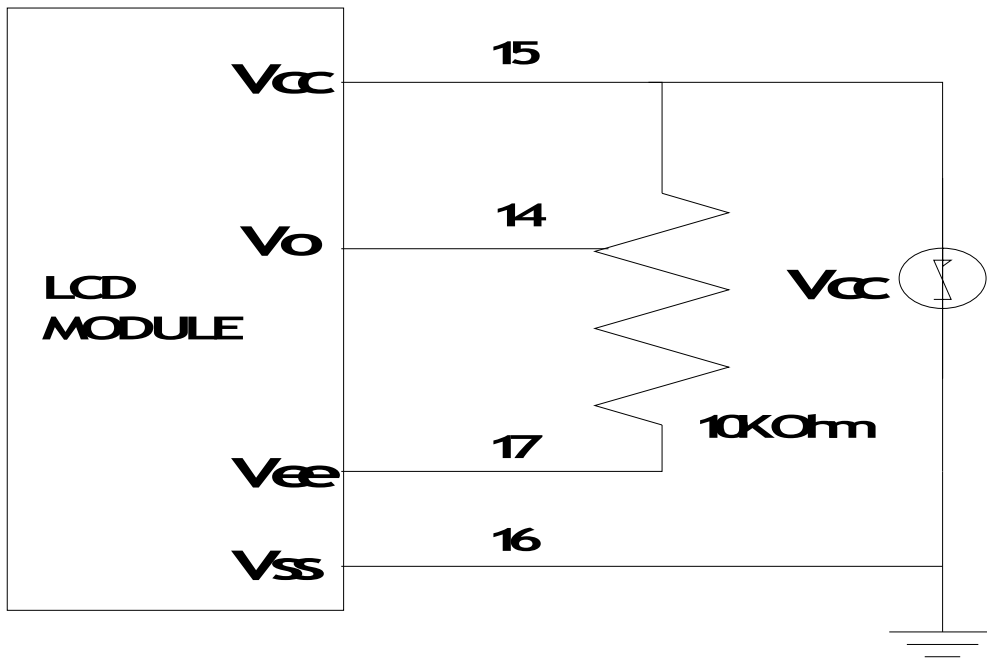

**Contrast adjust by using internal
Negative (Positive) voltage generator**

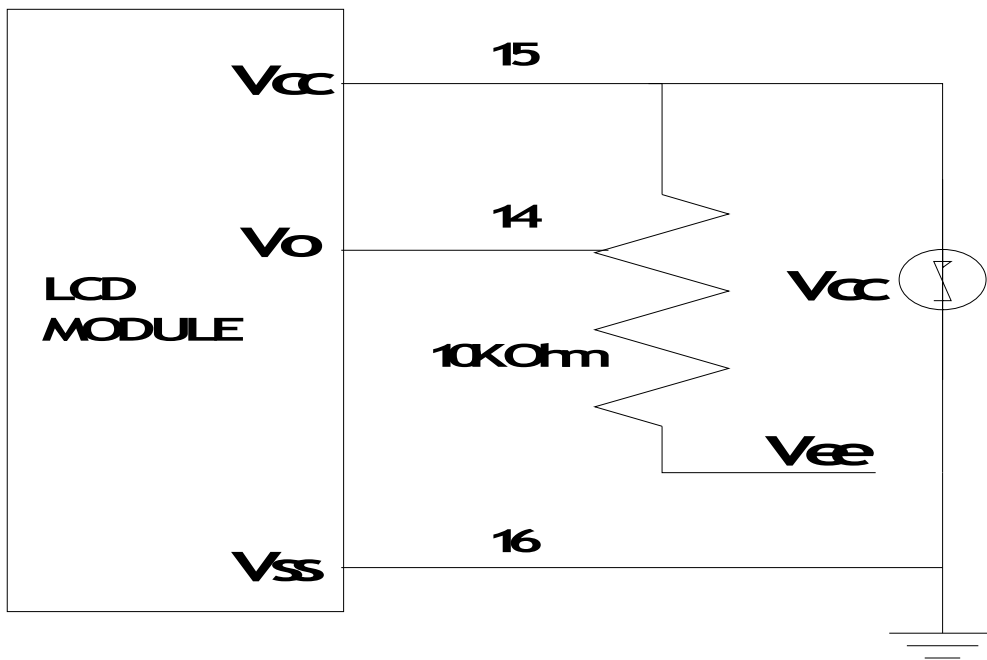

**Contrast adjust by using external
Negative (Positive) voltage generator**

8.Interface Description

Pin No.	Symbol	Level	Description
1	DB0	H / L	Data bus line
2	DB1	H / L	Data bus line
3	DB2	H / L	Data bus line
4	DB3	H / L	Data bus line
5	DB4	H / L	Data bus line
6	DB5	H / L	Data bus line
7	DB6	H / L	Data bus line
8	DB7	H / L	Data bus line
9	RS	H / L	H : Instruction , L : Data
10	R/ \overline{W}	H / L	H : read , L : write
11	E	H / L	Enable
12	\overline{CS}	L	Chip enable active “ L “
13	\overline{RESET}	L	Reset active “ L “
14	V _o		Power supply for LCD
15	V _{dd}		Power supply for logic circuit
16	V _{ss}		Ground
17	V _{ee}		Negative voltage output
18	$\overline{DISPOFF}$	H / L	H:on , L:off
19	LED(+)		LED +
20	LED(-)		LED-

9. Contour Drawing & Block Diagram

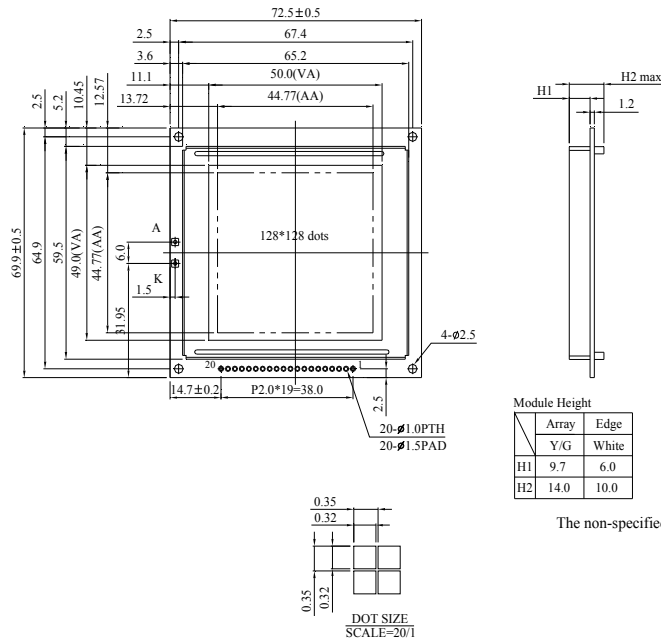

PIN NO.	SYMBOL
1	DB0
2	DB1
3	DB2
4	DB3
5	DB4
6	DB5
7	DB6
8	DB7
9	RS
10	R/W
11	E
12	CS
13	RES
14	Vo
15	Vdd
16	Vss
17	Vee
18	N.C
19	LED(+)
20	LED(-)

The non-specified tolerance of dimension is ±0.3mm.

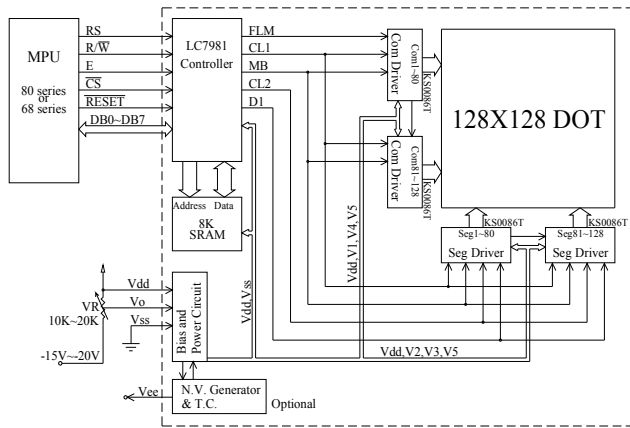

External contrast adjustment.

10. Display control instruction

The LCM has built-in a LC7981 LSI Controller, it stores display data sent from the 8 bit microcomputer in the display RAM attached externally and generates dot matrix LC drive signal. The LC7981 has two modes-the graphic mode, in which each bit of data from the external RAM either lights or doesn't light a dot in the LCD, and the character mode in which character codes stored in the external RAM generate dot patterns through the built-in character-generator ROM (CGROM)

below is its block diagram

Description of each block

□ Register

The LC7981 has 5 types of registers-the instruction register, data input register, data output register, dot register, and mode control register.

The instruction register stores such instruction codes as the start address, cursor address specification, etc. It consists of 4 bits, and the lower 4 bits of the data bus, DB0 to DB3, are written into it.

The data input register temporarily stores data to be written into the external RAM, dot register, and mode control register. It consists of 8 bits.

The data output register temporarily stores data to be read from external RAM, and consists of 8 bits. What the cursor address is written into the cursor address counter via the data input register and the memory read instruction is set in the instruction register, data in external RAM is read into the data output register by internal operation. With the next instruction, the MPU reads the data output register, and completes data transfer to the MPU.

The dot register stores dot information such as the character pitch, the number of vertical dots, etc. Data sent from the MPU is written into the dot register via the data input register.

The mode control register stores LCD status information such as display on/off and cursor on/off/blink. It consists of 6 bits. Data sent from the MPU is written into this register via the data input register.

□ Busy flag

When the Busy flag is "1", the LC7981 is operating internally. At this time, the next instruction cannot be accepted. The Busy flag is output to DB7 when RS=1, RW=1. The next instruction must be written after ensuring that the Busy flag is "0". When the maximum value of the read cycle time or write cycle time has been passed after the execution of the preceding data read instruction or data write instruction, the next instruction can be executed without checking the Busy flag.

□ Character generator ROM

The character generator ROM has a total of 7360 bits and stores data on 192 kinds of characters. Character codes from the external RAM and row codes from the row address counter are added to address signals, and ROM outputs 5-bit dot data.

There are 192 kinds of character fonts, of which 160 are 5×7 and 32 are 5×11 . With extended ROM, character fonts can be increased to 256 kinds sized 8×16 .

□ **Cursor address counter**

The cursor address counter is a 16-bit counter which can be preset by instruction.. When data is read from or written into external RAM (i. e., read/write of display dot data or character codes), the counter retains the addresses. The value indicated on the cursor address counter is automatically incremented by 1 when instructions to read/write display data and to perform bit set/clear are issued.

□ **Cursor signal generator**

In the character mode, the cursor can be displayed by means of instructions. The cursor is generated automatically when the cursor address counter and the row address counter reach the specified value.

□ **Display control instruction**

Display is controlled by writing data into the instruction register and 13 data registers. The instruction register and the data register are distinguished by the RS signal. First, write 4-bit data in the instruction register when $RS=1$, then specify the code of the data register. Next, with $RS=0$, write 8-bit data in the data register, which executes the specified instruction.

A new instruction cannot be accepted while an old instruction is being executed. As the Busy flag is set under this condition, write an instruction only after reading the Busy flag and making sure that it is 0.

However, the next instruction can be executed without checking the Busy flag when the maximum read cycle time or the write cycle time has been exceeded after execution of the previous data read instruction or the data write instruction. The Busy flag does not change when data is written into the instruction register ($RS=1$). Therefore, the Busy flag need not be checked immediately after writing data into the instruction register.

1) Mode control

Write code “00H” (in hexadecimal notation) in the instruction register and specify the mode control register.

Register	R/W	RS	DB7	DB6	DB5	DB4	DB3	DB2	DB1	DB0
Instruction Reg.	0	1	0	0	0	0	0	0	0	0
Mode control Reg.	0	0	0	0	MODE Data					

DB5	DB4	DB3	DB2	DB1	DB0	Cursor/blink	CG	Graphic/character display	
1/0	1/0	0	0	0	0	Cursor OFF	Built-in CG	Character display	
		0	1			Cursor ON			
		1	0			Cursor OFF			
		1	1						
		0	0			character blink			
		0	1			Cursor blink			
		1	0			1	Cursor OFF		External CG
		1	1			Cursor ON			
						Cursor OFF			
						character blink			
		Cursor blink							
		0	0	1	0			Graphic mode	
Display ON/OFF	Master/slave	Blink	Cursor	Mode	External/ Built in CG				

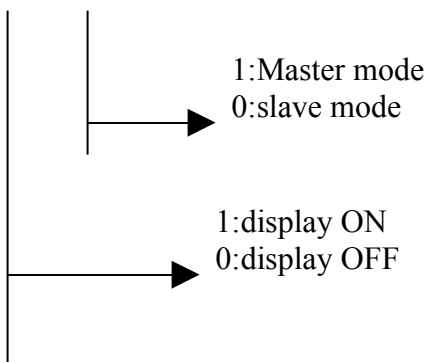

2)Setting the character pitch

Register	R/W	RS	DB7	DB6	DB5	DB4	DB3	DB2	DB1	DB0
Instruction Reg.	0	1	0	0	0	0	0	0	0	1
Character pitch Reg.	0	0	(Vp-1) Binary				0	(Hp-1) Binary		

Vp is the number of vertical dots per character. Determine Vp with the pitch between two vertically placed characters taken into consideration. This value is meaningful only in the character display mode: It is invalid in the graphic mode.

In character mode. Hp indicates the number of horizontal dots per character, from the leftmost part of one character to the leftmost part of the next. In the graphic mode, Hp indicates how many bits (or dots) from RAM appear in a 1-byte display.

Hp must take one of the following three values.

Hp	DB2	DB1	DB0	
6	1	0	1	Horizontal character pitch 6
7	1	1	0	Horizontal character pitch 7
8	1	1	1	Horizontal character pitch 8

3)Setting the number of characters

Register	R/W	RS	DB7	DB6	DB5	DB4	DB3	DB2	DB1	DB0
Instruction Reg.	0	1	0	0	0	0	0	0	1	0
Character number Reg.	0	0	(H _N -1) Binary							

in the character display mode, H_N indicates the number of characters in the horizontal direction. In the graphic mode, it indicates the number of bytes in the horizontal direction. The total number of dots positioned horizontally on the screen n is given by the formula

$$n = H_p \times H_N$$

Even numbers in the range 2 to 256 (decimal) can be set as H_N.

4)Setting the time division number (display duty)

Register	R/W	RS	DB7	DB6	DB5	DB4	DB3	DB2	DB1	DB0
Instruction Reg.	0	1	0	0	0	0	0	0	1	1
Time division Reg.	0	0	(N _x -1) Binary							

Consequently, 1/N_x is the display duty.

Decimal numbers with the range 1 to 256 can be set as N_x. please set N_x=64

5)Setting the cursor position

Register	R/W	RS	DB7	DB6	DB5	DB4	DB3	DB2	DB1	DB0
Instruction Reg.	0	1	0	0	0	0	0	1	0	0
Cursor position Reg.	0	0	0	0	0	0	(Cp-1) Binary			

In the character display mode, Cp indicates the line at which the cursor is displayed. For example, when Cp=8 (decimal) is specified, the cursor is displayed beneath the character of the 5×7 dot-font. The horizontal length of the cursor equals Hp (the horizontal character pitch). Decimal values in the range 1 to 16 can be assigned to Cp. When the value is less than the vertical character pitch Vp(Cp<Vp), display priority is given to the cursor (provided the cursor display is ON). The cursor is not displayed when Cp>Vp. The horizontal length of the cursor equals Hp.

6)Setting the display start lower address

Register	R/W	RS	DB7	DB6	DB5	DB4	DB3	DB2	DB1	DB0
Instruction Reg.	0	1	0	0	0	0	1	0	0	0
Display start address Reg. (lower byte)	0	0	(start address lower byte) binary							

7)Setting the display start upper address

Register	R/W	RS	DB7	DB6	DB5	DB4	DB3	DB2	DB1	DB0
Instruction Reg.	0	1	0	0	0	0	1	0	0	1
Display start address Reg. (upper byte)	0	0	(start address upper byte) binary							

This instruction writes the display start value in the display start address register. The display start address in the RAM address at which data to be displayed at the leftmost position of the top line of the screen is stored. The start address consists of 16 bits (upper and lower).

8)Setting the cursor (lower) address (RAM read/write lower address)

Register	R/W	RS	DB7	DB6	DB5	DB4	DB3	DB2	DB1	DB0
Instruction Reg.	0	1	0	0	0	0	1	0	1	0
Cursor address counter (lower byte)	0	0	(cursor address lower byte) binary							

9)Setting the cursor (upper) address (RAM read/write upper address)

Register	R/W	RS	DB7	DB6	DB5	DB4	DB3	DB2	DB1	DB0
Instruction Reg.	0	1	0	0	0	0	1	0	1	1
Cursor address counter (upper byte)	0	0	(cursor address upper byte) binary							

This instruction writes the cursor address value in the cursor address counter. The cursor address indicates the address for exchanging display data and character codes with RAM. In other words, data at the address specified by the cursor address is read from or written into RAM. In character display, the cursor is displayed at the position specified by the cursor address.

The cursor address is divided into a lower address (8 bits) and an upper address (8 bits). It should be set in accordance with the following rules.

1	To rewrite (set) both lower and upper addresses.	First set the lower address, then the upper.
2	To rewrite the lower address:	Always reset the upper address after setting the lower address.
3	To rewrite the upper address only:	Set the upper address. It is necessary to reset the lower address.

The cursor address counter is a 16-bit up-counter with set/reset functions: when the Nth bit goes from 1 to 0, the count of the (N+1)th bit increments by one. Accordingly, when the lower address is set so that the lower MSB (8th bit) changes from 1 to 0, the LSB (1st bit) of the upper counter must increment by one. When setting the cursor address, set the lower and upper addresses as a 2-byte continuous instruction.

10) Writing display data

Register	R/W	RS	DB7	DB6	DB5	DB4	DB3	DB2	DB1	DB0	
Instruction Reg.	0	1	0	0	0	0	1	1	0	0	
RAM	0	0	MSB (pattern data, character code)							LSB	

Write code “0CH” in the instruction register. Then, write 8-bit data with RS=0, and the data is written into RAM as display data or character codes at the address specified by the cursor address counter. After writing, the count of the cursor address counter increments by 1.

11) Reading display data

Register	R/W	RS	DB7	DB6	DB5	DB4	DB3	DB2	DB1	DB0	
Instruction Reg.	0	1	0	0	0	0	1	1	0	1	
RAM	1	0	MSB (pattern data, character code)							LSB	

Write “0DH” in the instruction register. Then, establish the read status with RS=0, and data in the RAM can be read. The procedure for reading data is as follows.

This instruction outputs the contents of the data output register to DB0 to 7, then transfers the RAM data indicated by the cursor address to the data output register. It then increments the cursor address by 1, which means that correct data cannot be read in the first read operation. The specified value is output in the second read operation. Accordingly, a dummy read operation must be performed once when reading data after setting the cursor address.

12)Bit clear

Register	R/W	RS	DB7	DB6	DB5	DB4	DB3	DB2	DB1	DB0
Instruction Reg.	0	1	0	0	0	0	1	1	1	0
Bit clear	0	0	0	0	0	0	0	(N _B -1) Binary		

13)Bit set

Register	R/W	RS	DB7	DB6	DB5	DB4	DB3	DB2	DB1	DB0
Instruction Reg.	0	1	0	0	0	0	1	1	1	1
Bit set	0	0	0	0	0	0	0	(N _B -1) Binary		

As the bit-clear or bit-set instruction, 1 bit of a 1 byte of data in display RAM is set to 0 or 1. The bit specified by N_B is set to 0 for the bit-clear instruction and 1 for the bit-set instruction. The RAM address is specified by the cursor address, which is automatically incremented by 1 at the completion of the instruction. N_B is a value in the range from 1 to 8. The LSB is indicated by N_B=1, and the MSB by N_B=8.

14)Reading the BUSY flag

Register	R/W	RS	DB7	DB6	DB5	DB4	DB3	DB2	DB1	DB0
busy flag	1	1	1/0	*						

The Busy flag is output to DB7 when read mode is established with RS=1. The Busy flag is set to 1 while any of the instructions 1) through 13) is being executed. It is set to 0 at the completion of the execution, allowing the next instruction to be accepted. No other instruction can be accepted when the Busy flag is 1. Accordingly, before writing an instruction and data, it is necessary to ensure that the Busy flag is 0. However, the next instruction can be executed without checking the Busy flag when the maximum read cycle time or the write cycle time has been exceeded after execution of the previous data read instruction or the data write instruction.

The Busy flag does not change when data is written into the instruction register (RS=1). Therefore, the Busy flag need not be checked immediately after writing data into the instruction register.

Specification of the instruction register is unnecessary to read the Busy flag.

The relation between the LCD panel display and H_p , H_N , C_p , V_p , and N_x

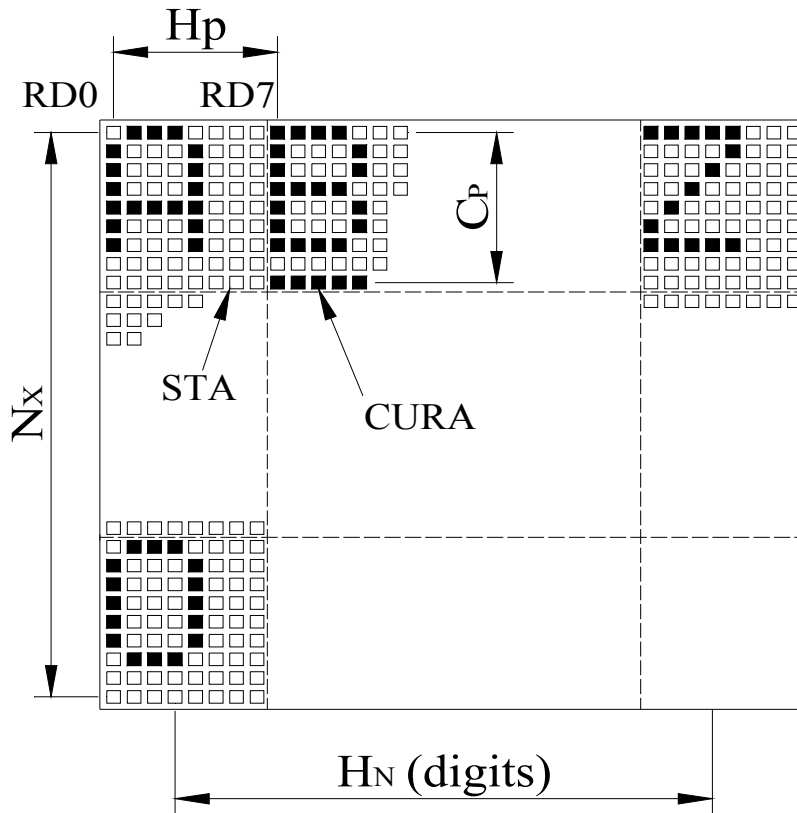

$C_p \square V_p$

Symbol	Description	Contents	Value
H_p	Horizontal character pitch	Character pitch in the horizontal direction	6 to 8 dots
H_N	Number of characters in the horizontal direction	Number of characters (digits) per horizontal line or the number of words per line (graphic)	Even digits in the range 2 to 256
V_p	Vertical character pitch	character pitch in the vertical direction	1 to 16 dots
C_p	Cursor position	The line number at which the cursor is to be displayed	1 to 16 lines
N_x	Number of lines in the vertical direction	Display duty	1 to 256 lines

Note)

When the number of vertical dots on the screen is m and that of horizontal dots is n ,

$\square \square 1/m = 1/N_x = \text{display duty} \quad (n_x=64)$

$\square \square n = H_p \times H_N$

$\square \square m/V_p = \text{number of display lines}, \quad C_p \square V_p$

Display mode

Display mode	Display data from the MPU	RAM	LCD Panel
Character display	<p>Display pattern (8 Bits)</p>	<p>Start address</p> <p>Hp</p>	<p>Hp: 6, 7 or 8 dots</p>
Graphic	<p>Character code (8 Bits)</p>	<p>Start address</p> <p>Hp</p>	<p>Hp: 8 dots</p>

1.1. Timing Characteristics

Upper 4 bit Lower 4 bit	LLLL	LLLH	LLHL	LLHH	LHLL	LHLH	LHHL	LHHH	HLLL	HLLH	HLHL	HLHH	HHLL	HHLH	HHHL	HHHH
LLLL				0	1	2	3	4				5	6	7	8	9
LLLH			:	A	B	C	D	E			F	G	H	I	J	K
LLHL			"	2	3	4	5	6			7	8	9	A	B	C
LLHH			*	3	4	5	6	7			8	9	A	B	C	D
LHLL			\$	4	5	6	7	8			9	A	B	C	D	E
LHLH			%	5	6	7	8	9			A	B	C	D	E	F
LHHL			@	6	7	8	9	A			B	C	D	E	F	G
LHHH			^	7	8	9	A	B			C	D	E	F	G	H
HLLL			(8	9	A	B	C			D	E	F	G	H	I
HLLH)	9	A	B	C	D			E	F	G	H	I	J
HLHL			*	A	B	C	D	E			F	G	H	I	J	K
HLHH			+	B	C	D	E	F			G	H	I	J	K	L
HHLL			.	C	D	E	F	G			H	I	J	K	L	M
HHLH			-	D	E	F	G	H			I	J	K	L	M	N
HHHL			^	E	F	G	H	I			J	K	L	M	N	O
HHHH			/	F	G	H	I	J			K	L	M	N	O	P

Read cycle

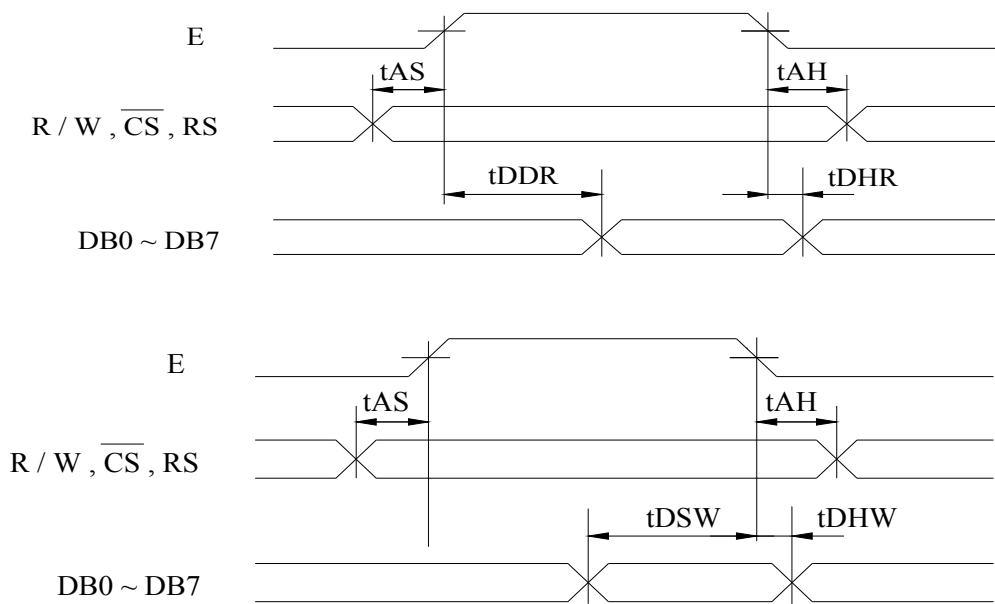

Write cycle

($V_{SS} = 0\text{ V}$, $V_{DD} = 5\text{ V}$)

Item	Symbol	Min	Typ	Max	Unit
Address set-up time	tAS	90	□	□	ns
Address hold time	tAH	10	□	□	ns
Data delay time (read)	tDDR	□	□	140	ns
Data hold time (read)	tDHR	10	□	□	ns
Data set-up time (write)	tDSW	220	□	□	ns
Data hold time (write)	tDHW	20	□	□	ns

Note : Definition of the test waveform

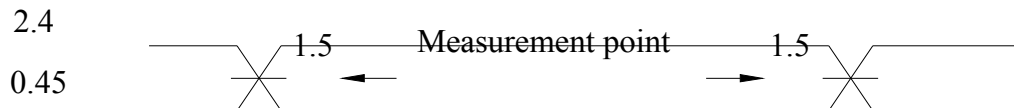

The input terminals are driven at 2.4V and 0.45V. Timing is measured at 1.5V.

12. Reliability

Content of Reliability Test (wide temperature, -20°C~70°C)

Environmental Test			
Test Item	Content of Test	Test Condition	Note
High Temperature storage	Endurance test applying the high storage temperature for a long time.	80°C 200hrs	2
Low Temperature storage	Endurance test applying the high storage temperature for a long time.	-30°C 200hrs	1,2
High Temperature Operation	Endurance test applying the electric stress (Voltage & Current) and the thermal stress to the element for a long time.	70°C 200hrs	—
Low Temperature Operation	Endurance test applying the electric stress under low temperature for a long time.	-20°C 200hrs	1
High Temperature/ Humidity Operation	The module should be allowed to stand at 60°C,90%RH max For 96hrs under no-load condition excluding the polarizer, Then taking it out and drying it at normal temperature.	60°C,90%RH 96hrs	1,2
Thermal shock resistance	The sample should be allowed stand the following 10 cycles of operation -20°C 25°C 70°C 30min 5min 30min 1 cycle	-20°C/70°C 10 cycles	—
Vibration test	Endurance test applying the vibration during transportation and using.	Total fixed amplitude : 1.5mm Vibration Frequency : 10~55Hz One cycle 60 seconds to 3 directions of X,Y,Z for Each 15 minutes	3
Static electricity test	Endurance test applying the electric stress to the terminal.	VS=800V,RS=1.5k Ω CS=100pF 1 time	—

Note1: No dew condensation to be observed.

Note2: The function test shall be conducted after 4 hours storage at the normal Temperature and humidity after remove from the test chamber.

Note3: Vibration test will be conducted to the product itself without putting it in a container.

13. Backlight Information

Specification

PARAMETER	SYMBOL	MIN	TYP	MAX	UNIT	TEST CONDITION
Supply Current	I _{LED}	64	80	120	mA	V=3.2V
Supply Voltage	V	3.4	3.5	3.6	V	□
Reverse Voltage	V _R	□	□	5	V	□
Luminous Intensity	I _V	120	140	□	CD/M ²	I _{LED} =80mA
Wave Length	λ _p		X=0.30 Y=0.31		nm	I _{LED} =80mA
Life Time	□	□	10000	□	Hr.	I _{LED} =80mA
Color	WHITE					

Note: The LED of B/L is drive by current only □ driving voltage is only for reference
 To make driving current in safety area (waste current between minimum and maximum).

LED B\L Drive Method Drive from A , K

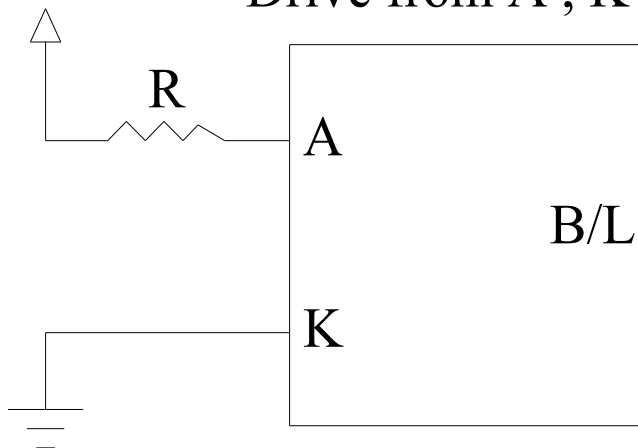

14. Material List of Components for RoHS

1. Crystalfontz America, Inc. hereby declares that all of or part of products (with the mark “#”in code), including, but not limited to, the LCM, accessories or packages, manufactured and/or delivered to your company (including your subsidiaries and affiliated company) directly or indirectly by our company (including our subsidiaries or affiliated companies) do not intentionally contain any of the substances listed in all applicable EU directives and regulations, including the following substances.

Exhibit A: The Harmful Material List

Material	(Cd)	(Pb)	(Hg)	(Cr6+)	PBBs	PBDEs
Limited Value	100 ppm	1000 ppm	1000 ppm	1000 ppm	1000 ppm	1000 ppm
Above limited value is set up according to RoHS.						

2.Process for RoHS requirement:

- (1) Use the Sn/Ag/Cu soldering surface: the surface of Pb-free solder is rougher than we used before.
- (2) Heat-resistance temp.:
Reflow: 250°C,30 seconds Max.
Connector soldering wave or hand soldering: 320°C, 10 seconds max.
- (3) Temp. curve of reflow, max. Temp.: 235±5°C
Recommended customer’s soldering temp. of connector: 280°C, 3 seconds.