

*PRELIMINARY*

# ***Crystalfontz America, Inc.***

## **SPECIFICATION**

**CUSTOMER :** \_\_\_\_\_

**MODULE NO.:** **CFAX12864T1-WFH**

<b>SALES BY</b>	<b>APPROVED BY</b>	<b>CHECKED BY</b>	<b>PREPARED BY</b>
<b>ISSUED DATE:</b>			

**Crystalfontz America, Inc.**

12412 East Saltese Avenue  
Spokane Valley, WA 99216-0357

Phone: (888) 206-9720

Fax: (509) 892-1203

Email:

[Htechinfo@crystalfontz.com](mailto:Htechinfo@crystalfontz.com)

URL: [Hwww.crystalfontz.com](http://www.crystalfontz.com)

***PRELIMINARY***

1. Module Classification Information
2. Precautions in use of LCD Modules
3. General Specification
4. Absolute Maximum Ratings
5. Electrical Characteristics
6. Optical Characteristics
7. Interface Description
8. Contour Drawing & Block Diagram
9. Function Description
10. Reliability
11. Backlight Information
12. Inspection specification
13. Material List of Components for RoHS

**PRELIMINARY**

## 1. Module Classification Information

CFA X    1 2 8 6 4    T1 – W F H  
 ①    ②                    ③            ④            ⑤ ⑥ ⑦

①	Brand : <b>CRYSTALFONTZ AMERICA, INCORPORATED</b>	
②	Display Type : H→Character Type, G→Graphic Type, <b>X→TAB Type</b>	
③	Display's logical dimensions: <b>128</b> pixels by <b>64</b> pixels	
④	Model variant: <b>T (1→module with ZIF tail)</b>	
⑤	Backlight Type :	N→Without backlight B→EL, Blue green D→EL, Green <b>W→EL, White</b> F→CCFL, White Y→LED, Yellow Green P→LED, Bule A→LED, Amber R→LED, Red O→LED, Orange G→LED, Green T→LED, White
⑥	LCD Mode :	B→TN Positive, Gray N→TN Negative, G→STN Positive, Gray Y→STN Positive, Yellow Green M→STN Negative, Blue <b>F→FSTN Positive</b> T→FSTN Negative
⑦	LCD Polarizer Type/ Temperature range/ View direction	A→Reflective, N.T, 6:00 D→Reflective, N.T, 12:00 G→Reflective, W. T, 6:00 J→Reflective, W. T, 12:00 B→Transflective, N.T,6:00 E→Transflective, N.T.12:00 <b>H→Transflective, W.T,6:00</b> K→Transflective, W.T,12:00 C→Transmissive, N.T,6:00 F→Transmissive, N.T,12:00 I→Transmissive, W. T, 6:00 L→Transmissive, W.T,12:00
⑧	Special Code	CB:

***PRELIMINARY***

## 2. Precautions in use of LCD Modules

- (1) Avoid applying excessive shocks to the module or making any alterations or modifications to it.
- (2) Don't make extra holes on the printed circuit board, modify its shape or change the components of LCD module.
- (3) Don't disassemble the LCM.
- (4) Don't operate it above the absolute maximum rating.
- (5) Don't drop, bend or twist LCM.
- (6) Soldering: only to the I/O terminals.
- (7) Storage: please storage in anti-static electricity container and clean environment.

## 3. General Specification

<b>Item</b>	<b>Dimension</b>	<b>Unit</b>
Number of Characters	128 x 64	—
Module dimension	36.5 x66.08 x2.3(MAX)	mm
View area	29.58x 17.98	mm
Active area	25.58x 15.98	mm
Dot size	0.23x 0.18	mm
Dot pitch	0.25 x 0.2	mm
LCD type	FSTN Positive Transflective (In LCD production, It will occur slightly color difference. We can only guarantee the same color in the same batch.)	
Duty	1/64	
View direction	6 o'clock	
Backlight Type	EL, White	

**PRELIMINARY**

## 4. Absolute Maximum Ratings

Item	Symbol	Min	Typ	Max	Unit
Operating Temperature	T <sub>OP</sub>	-20	—	+70	°C
Storage Temperature	T <sub>ST</sub>	-30	—	+80	°C
Input Voltage	V <sub>I</sub>	V <sub>SS</sub>	—	V <sub>DD</sub>	V
Supply Voltage For Logic	V <sub>DD</sub> -V <sub>SS</sub>	1.8	—	3.6	V
Supply Voltage For LCD	V <sub>OUT</sub> -V <sub>SS</sub>	6.0	—	14.2	V

## 5. Electrical Characteristics

Item	Symbol	Condition	Min	Typ	Max	Unit
Supply Voltage For Logic	V <sub>DD</sub> -V <sub>SS</sub>	—	3.0	3.3	3.6	V
Supply Voltage For LCD	V <sub>DD</sub> -V <sub>OUT</sub>	T <sub>a</sub> =-20°C	—	—	—	V
		T <sub>a</sub> =25°C	—	8.5	—	V
		T <sub>a</sub> =70°C	—	—	—	V
Input High Volt.	V <sub>IH</sub>	—	0.8 V <sub>DD</sub>	—	V <sub>DD</sub>	V
Input Low Volt.	V <sub>IL</sub>	—	V <sub>SS</sub>	—	0.2 V <sub>DD</sub>	V
Output High Volt.	V <sub>OH</sub>	—	0.8 V <sub>DD</sub>	—	V <sub>DD</sub>	V
Output Low Volt.	V <sub>OL</sub>	—	V <sub>SS</sub>	—	0.2 V <sub>DD</sub>	V
Supply Current	I <sub>DD</sub>	V <sub>DD</sub> =3.3V	0.18	0.18	0.18	mA

# 6. Optical Characteristics

Item	Symbol	Condition	Min	Typ	Max	Unit
View Angle	(V) $\theta$	$CR \geq 2$	30	—	60	deg
	(H) $\varphi$	$CR \geq 2$	-45	—	45	deg
Contrast Ratio	CR	—	—	5	—	—
Response Time	T rise	—	—	110	220	ms
	T fall	—	—	260	520	ms

## 6.1 Definitions

### ■ View Angles

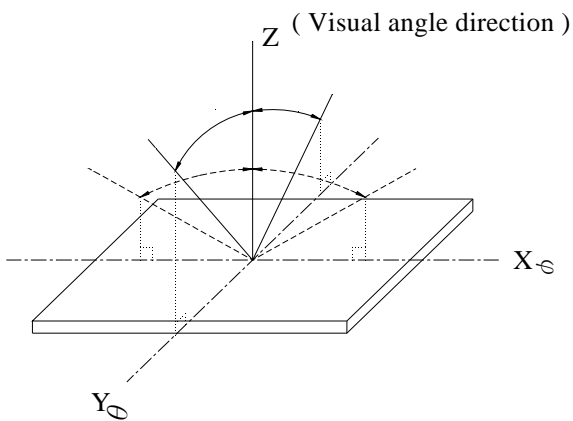

### ■ Contrast Ratio

$$CR = \frac{\text{Brightness at selected state (BS)}}{\text{Brightness at non-selected state (Bns)}}$$

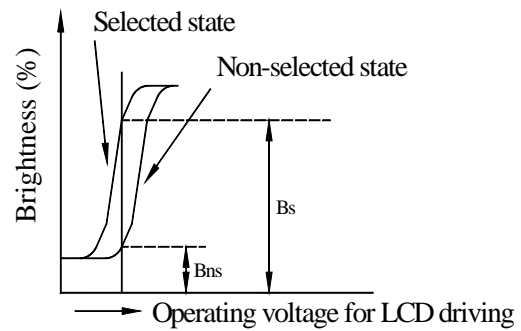

### ■ Response Time

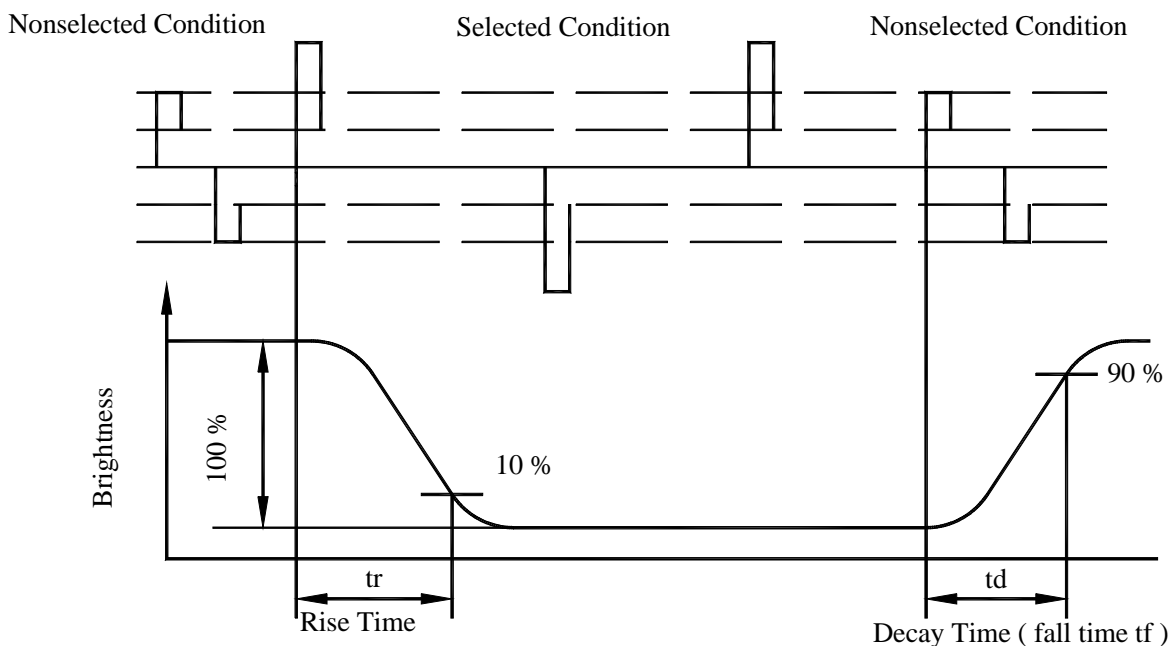

**PRELIMINARY**

## 7. Interface Description

Pin No.	Symbol	I/O	Description															
1	VDD	—	Power supply pin for logic.															
2	VSS	—	Ground pin, connected to 0V															
3	CS1B	I	Chip select input pins Data/instruction i/o is enabled only when CS1B is "L" and CS2 "H". When chip select is non-active, DB0 TO DB7 may be high impedance.															
4	CS2	I	Chip select input pins Data/instruction i/o is enabled only when CS1B is "L" and CS2 "H". When chip select is non-active, DB0 TO DB7 may be high impedance.															
5	RES	I	Reset input pin When RESETB is "L", initialization is executed.															
6	A0	I	This is connected to the least significant bit of the normal MPU address bus, and it determines whether the data bits are data or a command . A0="H": Indicate that D0 to D7 are display data A0="L": Indicate that D0 to D7 are control data															
7	R/W	I	When connected to 80-family MPU: Write enable clock input pin. The data ON DB0~DB7 are latched at the rising edge of the /WR signal. When connected to 68-family MPU: RW = "H": read RW = "L": write															
8	E	I	When connected to 80-family MPU: Read enable clock input pin. When /RD is "L", DB0~DB7 are in an output status When connected to 68-family MPU: RW = "H": When E is "H", DB0~DB7 are in an output status RW = "L": The data on DB0~DB7 are latched at the falling edge of the E signal															
9-16	DB0-DB7	I/O	8-bit bi-directional data bus that is connected to the standard 8-bit microprocessor data bus. When the serial interface selected (PS="L") DB0~DB5: high impedance DB6: serial input clock (SCLK) DB7: serial input data (SID) When chip select is not active, DB0~DB7 may be high impedance.															
17	C86	I	This is the MPU interface switch terminal C86 = "H": 6800 Series MPU interface C86 = "L": 8080 Series MPU interface															
18	P/S	I	This is the parallel data input/serial data input switch terminal P/S = "H": Parallel data input P/S = "L": Serial data input The following applies depending on the P/S status: <table border="1" style="margin-left: 20px;"> <thead> <tr> <th>P/S</th> <th>Data/Command</th> <th>Data</th> <th>Read/Write</th> <th>Serial Clock</th> </tr> </thead> <tbody> <tr> <td>"H"</td> <td>A0</td> <td>D0 to D7</td> <td>/RD, /WR</td> <td>-</td> </tr> <tr> <td>"L"</td> <td>A0</td> <td>SI (D7)</td> <td>Write only</td> <td>SCL (D6)</td> </tr> </tbody> </table> When P/S = "L", fix D0~D5 pads to VDD or VSS level. /RD(E) and /WR (R/W) are fixed to either "H" or "L". With serial data input, RAM display data reading is not supported.	P/S	Data/Command	Data	Read/Write	Serial Clock	"H"	A0	D0 to D7	/RD, /WR	-	"L"	A0	SI (D7)	Write only	SCL (D6)
P/S	Data/Command	Data	Read/Write	Serial Clock														
"H"	A0	D0 to D7	/RD, /WR	-														
"L"	A0	SI (D7)	Write only	SCL (D6)														

**PRELIMINARY**

# 8. Contour Drawing & Block Diagram

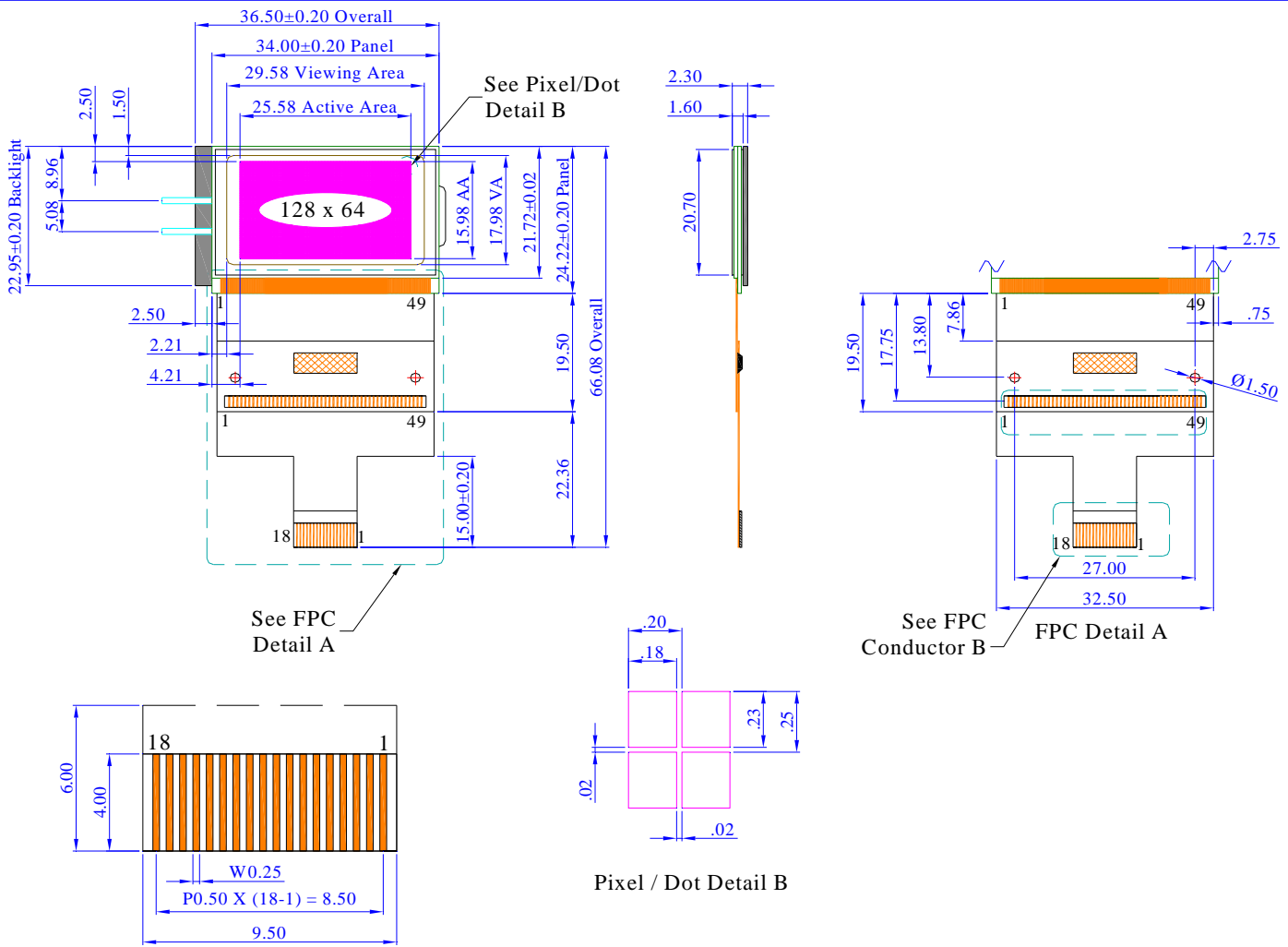

FPC Conductor Detail B



copyright © 2009 by  
**Crystalfontz America, Inc.**  
[www.crystalfontz.com/products/](http://www.crystalfontz.com/products/)

Part No.(s):  
CFAX12864T1-WFH

Scale:  
Not to scale  
Units:  
Millimeters

Drawing Number:  
CFAX12864T1\_master  
Date:  
2009/02/06

Hardware Rev.:  
vA  
Sheet:  
1 of 1



*PRELIMINARY*

## 9. Fuction Description

Refer to IC NT7534 data sheet

**PRELIMINARY**

# 10. RELIABILITY

**Content of Reliability Test (wide temperature, -20°C~70°C)**

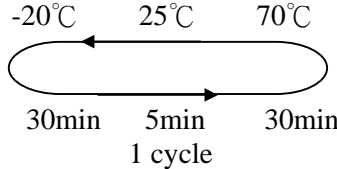
<b>Environmental Test</b>			
<b>Test Item</b>	<b>Content of Test</b>	<b>Test Condition</b>	<b>Note</b>
High Temperature storage	Endurance test applying the high storage temperature for a long time.	80°C 200hrs	2
Low Temperature storage	Endurance test applying the high storage temperature for a long time.	-30°C 200hrs	1,2
High Temperature Operation	Endurance test applying the electric stress (Voltage & Current) and the thermal stress to the element for a long time.	70°C 200hrs	—
Low Temperature Operation	Endurance test applying the electric stress under low temperature for a long time.	-20°C 200hrs	1
High Temperature/ Humidity Operation	The module should be allowed to stand at 60°C,90%RH max For 96hrs under no-load condition excluding the polarizer, Then taking it out and drying it at normal temperature.	60°C,90%RH 96hrs	1,2
Thermal shock resistance	The sample should be allowed stand the following 10 cycles of operation 	-20°C/70°C 10 cycles	—
Vibration test	Endurance test applying the vibration during transportation and using.	Total fixed amplitude : 15mm Vibration Frequency : 10~55Hz One cycle 60 seconds to 3 directions of X,Y,Z for Each 15 minutes	3
Static electricity test	Endurance test applying the electric stress to the terminal.	VS=800V,RS=1.5kΩ CS=100pF 1 time	—

**Note1: No dew condensation to be observed.**

**Note2: The function test shall be conducted after 4 hours storage at the normal Temperature and humidity after remove from the test chamber.**

**Note3: Vibration test will be conducted to the product itself without putting it in a container.**

**PRELIMINARY**

# 11. Backlight Information

## Specification

PARAMETER	SYMBOL	MIN	TYP	MAX	UNIT	TEST CONDITION
Drive Voltage	Vmax	—	110	—	Vrms	25°C
Drive Wave	Fmax	—	400	—	Hz	25°C
Brightness		30	37.5	—	cd/m <sup>2</sup>	110Vrms/400Hz
Chromatism	X	—	0.33	—	—	110Vrms/400Hz
	Y	—	0.65	—	—	110Vrms/400Hz
Life time			5000		hour	110Vrms/400Hz
Color			white		—	—

EL B\L drives directly from A , K.

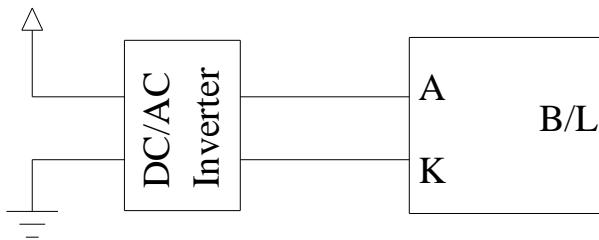

**PRELIMINARY**

# 12. Inspection specification

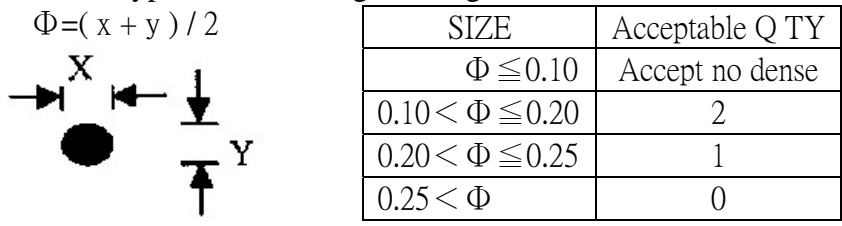
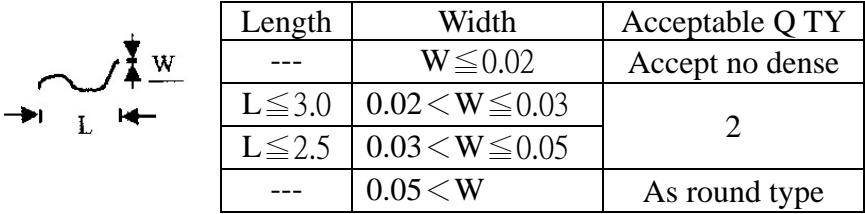
NO	Item	Criterion	AQL												
01	Electrical Testing	1.1 Missing vertical, horizontal segment, segment contrast defect. 1.2 Missing character , dot or icon. 1.3 Display malfunction. 1.4 No function or no display. 1.5 Current consumption exceeds product specifications. 1.6 LCD viewing angle defect. 1.7 Mixed product types. 1.8 Contrast defect.	0.65												
02	Black or white spots on LCD (display only)	2.1 White and black spots on display $\leq 0.25\text{mm}$ , no more than three white or black spots present. 2.2 Densely spaced: No more than two spots or lines within 3mm	2.5												
03	LCD black spots, white spots, contamination (non-display)	3.1 Round type : As following drawing $\Phi = (x + y) / 2$  <table border="1" style="margin-left: auto; margin-right: auto;"> <thead> <tr> <th>SIZE</th> <th>Acceptable Q TY</th> </tr> </thead> <tbody> <tr> <td><math>\Phi \leq 0.10</math></td> <td>Accept no dense</td> </tr> <tr> <td><math>0.10 &lt; \Phi \leq 0.20</math></td> <td>2</td> </tr> <tr> <td><math>0.20 &lt; \Phi \leq 0.25</math></td> <td>1</td> </tr> <tr> <td><math>0.25 &lt; \Phi</math></td> <td>0</td> </tr> </tbody> </table>	SIZE	Acceptable Q TY	$\Phi \leq 0.10$	Accept no dense	$0.10 < \Phi \leq 0.20$	2	$0.20 < \Phi \leq 0.25$	1	$0.25 < \Phi$	0	2.5		
		SIZE	Acceptable Q TY												
$\Phi \leq 0.10$	Accept no dense														
$0.10 < \Phi \leq 0.20$	2														
$0.20 < \Phi \leq 0.25$	1														
$0.25 < \Phi$	0														
3.2 Line type : (As following drawing)  <table border="1" style="margin-left: auto; margin-right: auto;"> <thead> <tr> <th>Length</th> <th>Width</th> <th>Acceptable Q TY</th> </tr> </thead> <tbody> <tr> <td>---</td> <td><math>W \leq 0.02</math></td> <td>Accept no dense</td> </tr> <tr> <td><math>L \leq 3.0</math></td> <td><math>0.02 &lt; W \leq 0.03</math></td> <td rowspan="2">2</td> </tr> <tr> <td><math>L \leq 2.5</math></td> <td><math>0.03 &lt; W \leq 0.05</math></td> </tr> <tr> <td>---</td> <td><math>0.05 &lt; W</math></td> <td>As round type</td> </tr> </tbody> </table>	Length	Width	Acceptable Q TY	---	$W \leq 0.02$	Accept no dense	$L \leq 3.0$	$0.02 < W \leq 0.03$	2	$L \leq 2.5$	$0.03 < W \leq 0.05$	---	$0.05 < W$	As round type	2.5
Length	Width	Acceptable Q TY													
---	$W \leq 0.02$	Accept no dense													
$L \leq 3.0$	$0.02 < W \leq 0.03$	2													
$L \leq 2.5$	$0.03 < W \leq 0.05$														
---	$0.05 < W$	As round type													
04	Polarizer bubbles	If bubbles are visible, judge using black spot specifications, not easy to find, must check in specify direction. <table border="1" style="margin-left: auto; margin-right: auto;"> <thead> <tr> <th>Size <math>\Phi</math></th> <th>Acceptable Q TY</th> </tr> </thead> <tbody> <tr> <td><math>\Phi \leq 0.20</math></td> <td>Accept no dense</td> </tr> <tr> <td><math>0.20 &lt; \Phi \leq 0.50</math></td> <td>3</td> </tr> <tr> <td><math>0.50 &lt; \Phi \leq 1.00</math></td> <td>2</td> </tr> <tr> <td><math>1.00 &lt; \Phi</math></td> <td>0</td> </tr> <tr> <td>Total Q TY</td> <td>3</td> </tr> </tbody> </table>	Size $\Phi$	Acceptable Q TY	$\Phi \leq 0.20$	Accept no dense	$0.20 < \Phi \leq 0.50$	3	$0.50 < \Phi \leq 1.00$	2	$1.00 < \Phi$	0	Total Q TY	3	2.5
Size $\Phi$	Acceptable Q TY														
$\Phi \leq 0.20$	Accept no dense														
$0.20 < \Phi \leq 0.50$	3														
$0.50 < \Phi \leq 1.00$	2														
$1.00 < \Phi$	0														
Total Q TY	3														

# PRELIMINARY

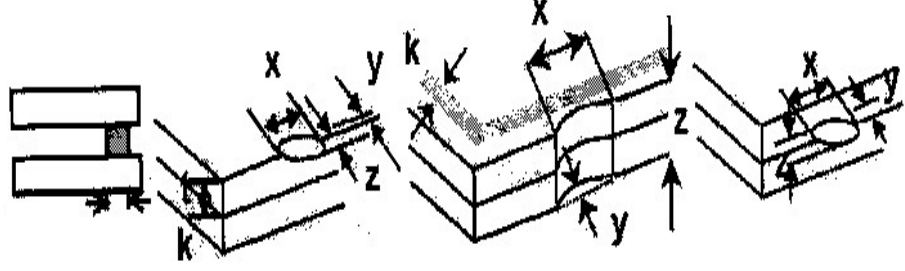
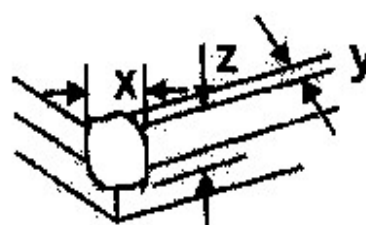
NO	Item	Criterion	AQL																		
05	Scratches	Follow NO.3 LCD black spots, white spots, contamination																			
06	Chipped glass	<p>Symbols Define:  x: Chip length            y: Chip width            z: Chip thickness  k: Seal width            t: Glass thickness       a: LCD side length  L: Electrode pad length:</p> <p>6.1 General glass chip :  6.1.1 Chip on panel surface and crack between panels:</p>  <table border="1" style="width: 100%; border-collapse: collapse; margin: 10px 0;"> <tr> <td style="width: 33%;">z: Chip thickness</td> <td style="width: 33%;">y: Chip width</td> <td style="width: 33%;">x: Chip length</td> </tr> <tr> <td><math>Z \leq 1/2t</math></td> <td>Not over viewing area</td> <td><math>x \leq 1/8a</math></td> </tr> <tr> <td><math>1/2t &lt; z \leq 2t</math></td> <td>Not exceed 1/3k</td> <td><math>x \leq 1/8a</math></td> </tr> </table> <p>⊙ If there are 2 or more chips, x is total length of each chip.</p> <p>6.1.2 Corner crack:</p>  <table border="1" style="width: 100%; border-collapse: collapse; margin: 10px 0;"> <tr> <td style="width: 33%;">z: Chip thickness</td> <td style="width: 33%;">y: Chip width</td> <td style="width: 33%;">x: Chip length</td> </tr> <tr> <td><math>Z \leq 1/2t</math></td> <td>Not over viewing area</td> <td><math>x \leq 1/8a</math></td> </tr> <tr> <td><math>1/2t &lt; z \leq 2t</math></td> <td>Not exceed 1/3k</td> <td><math>x \leq 1/8a</math></td> </tr> </table> <p>⊙ If there are 2 or more chips, x is the total length of each chip.</p>	z: Chip thickness	y: Chip width	x: Chip length	$Z \leq 1/2t$	Not over viewing area	$x \leq 1/8a$	$1/2t < z \leq 2t$	Not exceed 1/3k	$x \leq 1/8a$	z: Chip thickness	y: Chip width	x: Chip length	$Z \leq 1/2t$	Not over viewing area	$x \leq 1/8a$	$1/2t < z \leq 2t$	Not exceed 1/3k	$x \leq 1/8a$	2.5
z: Chip thickness	y: Chip width	x: Chip length																			
$Z \leq 1/2t$	Not over viewing area	$x \leq 1/8a$																			
$1/2t < z \leq 2t$	Not exceed 1/3k	$x \leq 1/8a$																			
z: Chip thickness	y: Chip width	x: Chip length																			
$Z \leq 1/2t$	Not over viewing area	$x \leq 1/8a$																			
$1/2t < z \leq 2t$	Not exceed 1/3k	$x \leq 1/8a$																			

# PRELIMINARY

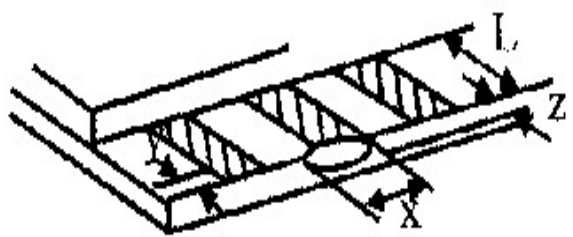
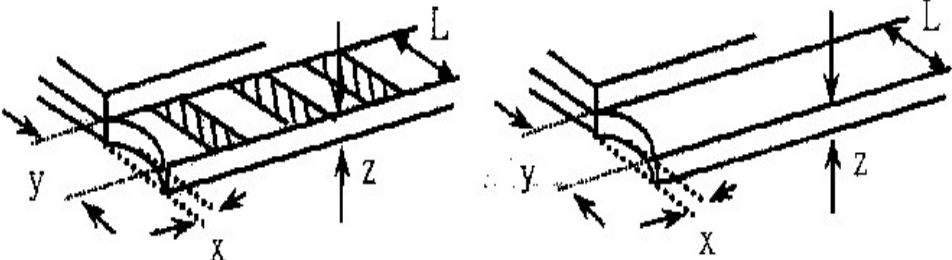
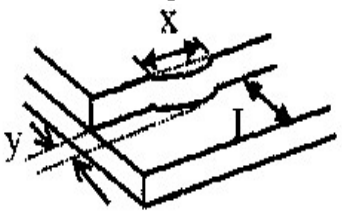
NO	Item	Criterion	AQL						
06	Glass crack	<p>Symbols :</p> <p>x: Chip length      y: Chip width      z: Chip thickness            k: Seal width      t: Glass thickness      a: LCD side length            L: Electrode pad length</p> <p>6.2 Protrusion over terminal :</p> <p>6.2.1 Chip on electrode pad :</p>							
									
		<table border="1" style="margin-left: auto; margin-right: auto;"> <tr> <td style="padding: 5px;">y: Chip width</td> <td style="padding: 5px;">x: Chip length</td> <td style="padding: 5px;">z: Chip thickness</td> </tr> <tr> <td style="padding: 5px;"><math>y \leq 0.5\text{mm}</math></td> <td style="padding: 5px;"><math>x \leq 1/8a</math></td> <td style="padding: 5px;"><math>0 &lt; z \leq t</math></td> </tr> </table>	y: Chip width	x: Chip length	z: Chip thickness	$y \leq 0.5\text{mm}$	$x \leq 1/8a$	$0 < z \leq t$	
		y: Chip width	x: Chip length	z: Chip thickness					
$y \leq 0.5\text{mm}$	$x \leq 1/8a$	$0 < z \leq t$							
<p>6.2.2 Non-conductive portion:</p>									
			2.5						
		<table border="1" style="margin-left: auto; margin-right: auto;"> <tr> <td style="padding: 5px;">y: Chip width</td> <td style="padding: 5px;">x: Chip length</td> <td style="padding: 5px;">z: Chip thickness</td> </tr> <tr> <td style="padding: 5px;"><math>y \leq L</math></td> <td style="padding: 5px;"><math>x \leq 1/8a</math></td> <td style="padding: 5px;"><math>0 &lt; z \leq t</math></td> </tr> </table>	y: Chip width	x: Chip length	z: Chip thickness	$y \leq L$	$x \leq 1/8a$	$0 < z \leq t$	
y: Chip width	x: Chip length	z: Chip thickness							
$y \leq L$	$x \leq 1/8a$	$0 < z \leq t$							
		<p>⊙If the chipped area touches the ITO terminal, over 2/3 of the ITO must remain and be inspected according to electrode terminal specifications.</p> <p>⊙If the product will be heat sealed by the customer, the alignment mark not be damaged.</p>							
		<p>6.2.3 Substrate protuberance and internal crack.</p>							
									
		<table border="1" style="margin-left: auto; margin-right: auto;"> <tr> <td style="padding: 5px;">y: width</td> <td style="padding: 5px;">x: length</td> </tr> <tr> <td style="padding: 5px;"><math>y \leq 1/3L</math></td> <td style="padding: 5px;"><math>x \leq a</math></td> </tr> </table>	y: width	x: length	$y \leq 1/3L$	$x \leq a$			
y: width	x: length								
$y \leq 1/3L$	$x \leq a$								

## **PRELIMINARY**

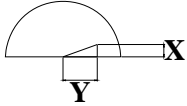
NO	Item	Criterion	AQL
07	Cracked glass	The LCD with extensive crack is not acceptable.	2.5
08	Backlight elements	8.1 Illumination source flickers when lit. 8.2 Spots or scratched that appear when lit must be judged. Using LCD spot, lines and contamination standards. 8.3 Backlight doesn't light or color wrong.	0.65 2.5 0.65
09	Bezel	9.1 Bezel may not have rust, be deformed or have fingerprints, stains or other contamination. 9.2 Bezel must comply with job specifications.	2.5 0.65
10	PCB、COB	10.1 COB seal may not have pinholes larger than 0.2mm or contamination. 10.2 COB seal surface may not have pinholes through to the IC. 10.3 The height of the COB should not exceed the height indicated in the assembly diagram. 10.4 There may not be more than 2mm of sealant outside the seal area on the PCB. And there should be no more than three places. 10.5 No oxidation or contamination PCB terminals. 10.6 Parts on PCB must be the same as on the production characteristic chart. There should be no wrong parts, missing parts or excess parts. 10.7 The jumper on the PCB should conform to the product characteristic chart. 10.8 If solder gets on bezel tab pads, LED pad, zebra pad or screw hold pad, make sure it is smoothed down. 10.9 The Scraping testing standard for Copper Coating of PCB  $X * Y \leq 2\text{mm}^2$	2.5 2.5 0.65 2.5 2.5 0.65 0.65 2.5 2.5
11	Soldering	11.1 No un-melted solder paste may be present on the PCB. 11.2 No cold solder joints, missing solder connections, oxidation or icicle. 11.3 No residue or solder balls on PCB. 11.4 No short circuits in components on PCB.	2.5 2.5 2.5 0.65

## ***PRELIMINARY***

NO	Item	Criterion	AQL
12	General appearance	12.1 No oxidation, contamination, curves or, bends on interface Pin (OLB) of TCP.	2.5
		12.2 No cracks on interface pin (OLB) of TCP.	0.65
		12.3 No contamination, solder residue or solder balls on product.	2.5
		12.4 The IC on the TCP may not be damaged, circuits.	2.5
		12.5 The uppermost edge of the protective strip on the interface pin must be present or look as if it causes the interface pin to sever.	2.5
		12.6 The residual rosin or tin oil of soldering (component or chip component) is not burned into brown or black color.	2.5
		12.7 Sealant on top of the ITO circuit has not hardened.	0.65
		12.8 Pin type must match type in specification sheet.	0.65
		12.9 LCD pin loose or missing pins.	0.65
		12.10 Product packaging must the same as specified on packaging specification sheet.	0.65
		12.11 Product dimension and structure must conform to product specification sheet.	



**PRELIMINARY**

# 13. Material List of Components for RoHS

1. Crystalfontz America, Inc. hereby declares that all of or part of products, including, but not limited to, the LCM, accessories or packages, manufactured and/or delivered to your company (including your subsidiaries and affiliated company) directly or indirectly by our company (including our subsidiaries or affiliated companies) do not intentionally contain any of the substances listed in all applicable EU directives and regulations, including the following substances.

Exhibit A : The Harmful Material List

Material	(Cd)	(Pb)	(Hg)	(Cr6+)	PBBs	PBDEs
Limited Value	100 ppm	1000 ppm	1000 ppm	1000 ppm	1000 ppm	1000 ppm
Above limited value is set up according to RoHS.						

2.Process for RoHS requirement :

- (1) Use the Sn/Ag/Cu soldering surface ; the surface of Pb-free solder is rougher than we used before.
- (2) Heat-resistance temp. :  
Reflow : 250°C,30 seconds Max. ;  
Connector soldering wave or hand soldering : 320°C, 10 seconds max.
- (3) Temp. curve of reflow, max. Temp. : 235±5°C ;  
Recommended customer's soldering temp. of connector : 280°C, 3 seconds.