



ePAPER DISPLAY MODULE DATASHEET



Datasheet Release 2018-07-17
for
CFAP128296E0-0290

Crystalfontz America, Inc.

12412 East Saltese Avenue
Spokane Valley, WA 99216-0357
Phone: 888-206-9720
Fax: 509-892-1203
Email: support@crystalfontz.com
URL: www.crystalfontz.com

CONTENTS

1. General Information.....	3
2. Description Overview	4
3. Features	4
4. Mechanical Specifications	4
5. Input/Output Terminals.....	5
5.1. Pin Out List.....	5
6. Command Table	7
7. Electrical Characteristics	26
7.1. Absolute Maximum Rating	26
7.2. Panel DC Characteristics	26
7.3. Panel AC Characteristics	27
7.3.1. Oscillator Frequency	27
7.3.2. MCU Interface Selection	27
7.3.3. MCU Serial Interface (4-Wire SPI)	27
7.3.4. MCU Serial Interface (3-Wire SPI)	28
7.3.5. Timing Characteristics of Series Interface	29
7.4. Power Consumption	30
7.5. Reference Circuit.....	30
8. Typical Operating Sequence.....	33
8.1. Normal Operation Flow	33
8.1.1. BWY Mode & LUT from Register	33
8.1.2. BWY Mode & LUT from OTP	34
8.2. Reference Program Code	35
8.2.1. BWY Mode & LUT from Register	35
8.2.2. BWY Mode & LUT from OTP	36
9. Optical Characteristics	37
9.1. Specifications	37
9.2. Definition of Contrast Ratio	37
9.3. Reflection Ratio	38
9.4. Bi-Stability	38
10. Mechanical Drawing.....	39
11. ePaper Breakout Board Schematic.....	40

1. General Information

Datasheet Revision History

Datasheet Release Date: **2018-07-17**
Datasheet for the CFAP128296E0-0290 ePaper display module.

Product Change Notifications

You can check for or subscribe to [Part Change Notices](#) for this display module on our website.

Variations

Slight variations between lots are normal (e.g., contrast, color, or intensity).

Volatility

This display module has volatile memory.

Disclaimer

Certain applications using CrystalFontz America, Inc. products may involve potential risks of death, personal injury, or severe property or environmental damage ("Critical Applications"). CRYSTALFONTZ AMERICA, INC. PRODUCTS ARE NOT DESIGNED, INTENDED, AUTHORIZED, OR WARRANTED TO BE SUITABLE FOR USE IN LIFE-SUPPORT APPLICATIONS, DEVICES OR SYSTEMS OR OTHER CRITICAL APPLICATIONS. Inclusion of CrystalFontz America, Inc. products in such applications is understood to be fully at the risk of the customer. In order to minimize risks associated with customer applications, adequate design and operating safeguards should be provided by the customer to minimize inherent or procedural hazard. Please contact us if you have any questions concerning potential risk applications.

CrystalFontz America, Inc. assumes no liability for applications assistance, customer product design, software performance, or infringements of patents or services described herein. Nor does CrystalFontz America, Inc. warrant or represent that any license, either express or implied, is granted under any patent right, copyright, or other intellectual property right of CrystalFontz America, Inc. covering or relating to any combination, machine, or process in which our products or services might be or are used.

All specifications in datasheets on our website are, to the best of our knowledge, accurate but not guaranteed. Corrections to specifications are made as any inaccuracies are discovered.

Company and product names mentioned in this publication are trademarks or registered trademarks of their respective owners.

Copyright © 2018 by CrystalFontz America, Inc., 12412 East Saltese Avenue, Spokane Valley, WA 99216 U.S.A.

2. Description Overview

This ePaper display is a TFT active matrix electrophoretic display with interface and a reference system design. The 2.9" active area contains 296x128 pixels and has 1-bit white/black and 1-bit yellow full display capabilities. An integrated circuit contains a gate buffer, source buffer, interface, timing control logic, oscillator, DC-DC, SRAM, LUT, VCOM, and border are supplied with each panel.

3. Features

- High Contrast
- High Reflectance
- Ultra-Wide Viewing Angle
- Ultra-Low Power Consumption
- Pure Reflective Mode
- Bi-Stable Display
- Commercial Temperature Range
- Landscape or Portrait Mode
- Antiglare Hard-Coated Front-Surface
- Low Current Deep Sleep Mode
- On-Chip Display RAM
- Waveform Stored in On-Chip OTP
- Serial Peripheral Interface Available
- On-Chip Oscillator
- On-Chip Booster and Regulator Control for Generating V_{COM} , Gate and Source Driving Voltage
- I²C Signal Master Interface to Read External Temperature Sensor
- Available in COG Package IC Thickness 280um

4. Mechanical Specifications

Parameter	Specifications	Unit	Remark
Screen Size	2.9	inch	-
Display Resolution	296 (H) × 128 (W)	pixel	dpi: 112
Active Area	66.90 (H) × 29.06 (W)	mm	-
Pixel Pitch	0.227 × 0.226	mm	-
Pixel Configuration	Square	-	-
Outline Dimension	79.0 (H) × 36.7 (W) × 1.18 (D)	mm	-
Weight (typical)	6.8	g	-



5. Input/Output Terminals

5.1. Pin Out List

Pin #	Type	Single	Description	Remark
1	-	NC	No Connection and Do Not Connect with Other NC Pins	Keep Open
2	O	GDR	N-Channel MOSFET Gate Drive Control	
3	O	RESE	Current Sense Input for the Control Loop	
4	C	VGL	Negative Gate Driving Voltage	
5	C	VGH	Positive Gate Driving Voltage	
6	O	TSCL	I ² C Interface to Digital Temperature Sensor Clock Pin	
7	I/O	TSDA	I ² C Interface to Digital Temperature Sensor Data Pin	
8	I	BS1	Bus Selection Pin	Note 5-5
9	O	BUSY	Busy State Output Pin	Note 5-4
10	I	RES#	Reset	Note 5-3
11	I	D/C#	Data / Command Control Pin	Note 5-2
12	I	CS#	Chip Select Input Pin	Note 5-1
13	I/O	D0	Serial Clock Pin (SPI)	
14	I/O	D1	Serial Data Pin (SPI)	
15	I	VDDIO	Power for Interface Logic Pins	
16	I	VCI	Power Supply Pin for Chip	
17	-	VSS	Ground	
18	C	VDD	Core Logic Power Pin	
19	C	VPP	Power Supply for OTP Programming	
20	C	VSH	Positive Source Driving Voltage	
21	C	PREVGH	Power Supply Pin for VGH and VSH	
22	C	VSL	Negative Source Driving Voltage	
23	C	PREVGL	Power Supply Pin for VCOM, VGL, and VSL	
24	C	VCOM	VCOM Driving Voltage	



Note (5-1): This pin (CS#) is the chip select input connecting to the MCU. The chip is enabled for MCU communication only when CS# is pulled LOW.

Note (5-2): This pin (D/C#) is the Data/Command control pin connecting to the MCU. When the pin is pulled HIGH, the data will be interpreted as data. When the pin is pulled LOW, the data will be interpreted as command.

Note (5-3): This pin (RES#) is the reset signal input. The reset is active LOW.

Note (5-4): This pin (BUSY) is the Busy state output pin. When busy is LOW, the operation of chip should not be interrupted and no commands should be issued to the module. The driver IC will put Busy pin LOW when the driver IC is working such as

- Outputting Display Waveform; or
- Programming with OTP
- Communicating with Digital Temperature Sensor

Note (5-5): This pin (BS1) is for 3-line SPI or 4-line SPI selection. When it is "LOW", 4-line SPI is selected. When it is "HIGH", 3-line SPI (9 bits SPI) is selected. Please refer to the table below.

Table: Bus Interface Selection

BS1	MPU Interface
L	4-Lines Serial Peripheral Interface (SPI)
H	3-Lines Serial Peripheral Interface (SPI) – 9 bits SPI



6. Command Table

W/R: 0: Write cycle 1: Read cycle C/D: 0: Command 1: Data D7~D0:-: Don't care #: Valid Data

#	Command	W/R	C/D	D7	D6	D5	D4	D3	D2	D1	D0	Registers	Default
1	Panel Setting (PSR)	0	0	0	0	0	0	0	0	0	0		00h
		0	1	#	#	#	#	#	#	#	#	RES[1:0],REG,KW/R,UD, SHL, SHD_N, RST_N	0Fh
2	Power Setting (PWR)	0	0	0	0	0	0	0	0	0	1		01h
		0	1	-	-	-	-	-	-	#	#	VDS_EN,VDG_EN	03h
		0	1	-	-	-	-	-	#	#	#	VCOM_HV, VGHL_LV[1:0]	00h
		0	1	-	-	#	#	#	#	#	#	VDH[5:0]	26h
		0	1	-	-	#	#	#	#	#	#	VDL[5:0]	26h
		0	1	-	-	#	#	#	#	#	#	VDHY[5:0]	03h
3	Power OFF(POF)	0	0	0	0	0	0	0	0	1	0		02h
4	Power OFF Sequence Setting (PFS)	0	0	0	0	0	0	0	0	1	1		03h
		0	1	-	-	#	#	-	-	-	-	T_VDS_OF	00h
5	Power ON (PON)	0	0	0	0	0	0	0	1	0	0		04h
6	Power ON Measure (PMES)	0	0	0	0	0	0	0	1	0	1		05h
7	Booster Soft Start (BTST)	0	0	0	0	0	0	0	1	1	0		06h
		0	1	#	#	#	#	#	#	#	#	BT_PHA[7:0]	17h
		0	1	#	#	#	#	#	#	#	#	BT_PHB[7:0]	17h
		0	1	-	-	#	#	#	#	#	#	BT_PHC[5:0]	17h
8	Deep Sleep	0	0	0	0	0	0	0	1	1	1		07h
		0	1	1	0	1	0	0	1	0	1	Check Code	A5h
9	Data Start Transmission 1 (DTM1, white/black data) (x-byte command)	0	0	0	0	0	1	0	0	0	0	B/W Pixel Data (160x296)	10h
		0	1	#	#	#	#	#	#	#	#	KPXL[1:8]	00h
		0	1	-
		0	1	#	#	#	#	#	#	#	#	KPXL[n-1:n]	00h
10	Data Stop (DSP)	0	0	0	0	0	1	0	0	0	1		11h
		1	1	#	-	-	-	-	-	-	-		00h
11	Display Refresh (DRF)	0	0	0	0	0	1	0	0	1	0		12h
12	Data Start Transmission 2 (DTM2, Yellow Data) (x-byte command)	0	0	0	0	0	1	0	0	1	1	Yellow Pixel Data (160x296)	13h
		0	1	#	#	#	#	#	#	#	#	YPXL[1:8]	00h
		0	1
		0	1	#	#	#	#	#	#	#	#	YPXL[n-1:n]	00h



#	Command	W/R	C/D	D7	D6	D5	D4	D3	D2	D1	D0	Registers	Default
13	VCOM LUT (LUTC) (45-byte command, structure of bytes 2~7 repeated)	0	0	0	0	1	0	0	0	0	0		20h
14	W2W LUT (LUTWW) (43-byte command, structure of bytes 2~7 repeated 7 times)	0	0	0	0	1	0	0	0	0	1		21h
15	B2W LUT (LUTBW / LUTR) (43-byte command, structure of bytes 2~7 repeated 7 times)	0	0	0	0	1	0	0	0	1	0		22h
16	W2B LUT (LUTWB / LUTW) (43-byte command, structure of bytes 2~7 repeated 7 times)	0	0	0	0	1	0	0	0	1	1		23h
17	B2B LUT (LUTBB / LUTB) (43-byte command, structure of bytes 2~7 repeated 7 times)	0	0	0	0	1	0	0	1	0	0		24h
18	PLL Control (PLL)	0	0	0	0	1	1	0	0	0	0		30h
		0	1	-	-	#	#	#	#	#	#	M[2:0], N[2:0]	3Ch
19	Temperature Sensor Calibration (TSC)	0	0	0	1	0	0	0	0	0	0		40h
		1	1	#	#	#	#	#	#	#	#	LM[10:3]/TSR[7:0]	00h
		1	1	#	#	#	-	-	-	-	-	LM[2:0]/-	00h
20	Temperature Sensor Selection (TSE)	0	0	0	1	0	0	0	0	0	1		41h
		0	1	#	-	-	-	#	#	#	#	TSE, TO[3:0]	00h
21	Temperature Sensor Write (TSW)	0	0	0	1	0	0	0	0	1	0		42h
		0	1	#	#	#	#	#	#	#	#	WATTR[7:0]	00h
		0	1	#	#	#	#	#	#	#	#	WMSB[7:0]	00h
		0	1	#	#	#	#	#	#	#	#	WLSB[7:0]	00h



#	Command	W/R	C/D	D7	D6	D5	D4	D3	D2	D1	D0	Registers	Default		
22	Temperature Sensor Read (TSR)	0	0	0	1	0	0	0	0	1	1		43h		
		1	1	#	#	#	#	#	#	#	#	RMSB[7:0]	00h		
		1	1	#	#	#	#	#	#	#	#	RLSB[7:0]	00h		
23	V _{COM} and Data Interval Setting (CDI)	0	0	0	1	0	1	0	0	0	0		50h		
		0	1	#	#	#	#	#	#	#	#	VBD[1:0],DDX[1:0],CDI[3:0]	D7h		
24	Low Power Detection (LPD)	0	0	0	1	0	1	0	0	0	1		51h		
		1	1	-	-	-	-	-	-	-	-	#	LPD	01h	
25	TCON Setting (TCON)	0	0	0	1	1	0	0	0	0	0		60h		
		0	1	#	#	#	#	#	#	#	#	S2G[3:0],G2S[3:0]	22h		
26	Resolution Setting (TRES)	0	0	0	1	1	0	0	0	0	1		61h		
		0	1	#	#	#	#	#	#	#	0	HRES[7:3]	00h		
		0	1	-	-	-	-	-	-	-	-	#	VRES[8:0]	00h	
		0	1	#	#	#	#	#	#	#	#	#		00h	
27	Get Status (FLG)	0	0	0	1	1	1	0	0	0	1		71h		
		1	1	-	#	#	#	#	#	#	#	#	PTL_FLAG, I ² C_BUSY, DATA_FLAG, PON, POF, BUSY	02h	
28	Auto Measure V _{COM}	0	0	1	0	0	0	0	0	0	0		80h		
		0	1	-	-	#	#	#	#	#	#	#	AMVT[1:0], XON, AMVS, AMV, AMVE	10h	
29	Read V _{COM} Value (VV)	0	0	1	0	0	0	0	0	0	1		81h		
		1	1	-	-	#	#	#	#	#	#	#	VV[5:0]	00h	
30	VCM_DC Setting (VDCS)	0	0	1	0	0	0	0	0	1	0		82h		
		0	1	-	-	#	#	#	#	#	#	#	VDCS[5:0]	00h	
31	Partial Window (PTL)	0	0	1	0	0	1	0	0	0	0		90h		
		0	1	#	#	#	#	#	0	0	0	HRST[7:3]	00h		
		0	1	#	#	#	#	#	1	1	1	HYELLOW[7:3]	07h		
		0	1	-	-	-	-	-	-	-	-	#	VRST[8:0]	00h	
		0	1	#	#	#	#	#	#	#	#	#		00h	
		0	1	-	-	-	-	-	-	-	-	-	#	VYELLOW[8:0]	00h
		0	1	#	#	#	#	#	#	#	#	#	00h		
		0	1	-	-	-	-	-	-	-	-	-	#	PT_SCAN	01h
32	Partial In (PTIN)	0	0	1	0	0	1	0	0	0	1		91h		
33	Partial Out (PTOUT)	0	0	1	0	0	1	0	0	1	0		92h		



#	Command	W/R	C/D	D7	D6	D5	D4	D3	D2	D1	D0	Registers	Default	
34	Program Mode (PGM)	0	0	1	0	1	0	0	0	0	0		A0h	
		0	1	1	0	1	0	0	1	0	1	Check Code = A5h	A5h	
35	Active Program (APG)	0	0	1	0	1	0	0	0	0	1		A1h	
36	Read OTP (ROTP)	0	0	1	0	1	0	0	0	1	0		A2h	
		1	1	-	-	-	-	-	-	-	-	-	Read Dummy	N/A
		1	1	#	#	#	#	#	#	#	#	#	Data of Address = 000h	N/A
		1	1	N/A
		1	1	#	#	#	#	#	#	#	#	#	Data of Address = n	N/A
37	Power Saving (PWS)	0	0	1	1	1	0	0	0	1	1		E3h	
		0	1	#	#	#	#	#	#	#	#	#	VCOM_W[3:0],SD_W[3:0]	00h

(1) Panel Setting (PSR) (Register: R00H)

Action	W/R	C/D	D7	D6	D5	D4	D3	D2	D1	D0
Setting the panel	0	0	0	0	0	0	0	0	0	0
	0	1	RES1	RES0	REG_EN	BWY	UD	SHL	SHD_N	RST_N

RES [1:0]: Display Resolution setting (source x gate)

00b: 96x230 (Default) Active source channels: S0~S95. Active gate channels: G0~G299.
 01b: 96x252 Active source channels: S0~S95. Active gate channels: G0~G251.
 10b: 128x296 Active source channels: S0~S127. Active gate channels: G0~G295.
 11b: 160x296 Active source channels: S0~S159. Active gate channels: G0~G295.

REG_EN: LUT selection

0: LUT from OTP. (Default)
 1: LUT from register

BWY: Black / White / Yellow

0: Pixel with B/W/Yellow. (Default)
 1: Pixel with B/W.

UD: Gate Scan Direction

0: Scan down. First line to last line: Gn-1 → Gn-2 → Gn-3 →...→ G0
 1: Scan up. (Default) First line to last line: G0 → G1 → G2 →...→ Gn-1

SHL: Source Shift direction

0: Shift left. First data to last data: Sn-1 → Sn-2 → Sn-3 →...→ S0
 1: Shift right. (Default) First data to last data: S0 → S1 → S2 →...→ Sn-1

SHD_N: Booster Switch

0: Booster OFF, register data are kept, and SEG/BG/VCOM are kept 0V or floating.
 1: Booster ON (Default)

When SHD_N becomes LOW, charge pump will be turned OFF, register and SRAM data will keep until VDD OFF, and SD output and VCOM will be based on previous condition and keep floating. SHD_N may have two conditions: 0V or floating.

RST_N: Soft Reset

0: No effect. (Default) Booster OFF, Register data are set to their default values, and SEG/BG/VCOM: 0V.

When RST_N becomes LOW, the driver will be reset; all registers will be reset to their default value. All driver functions will be disabled. SD output and VCOM will be based on previous condition. It may have two conditions: 0V or floating.

(2) Power Setting (R01H)

Action	W/R	C/D	D7	D6	D5	D4	D3	D2	D1	D0
Selecting Internal/External Power	0	0	0	0	0	0	0	0	0	1
	0	1	-	-	-	-	-	-	VDS_EN	V DG_EN
	0	1	-	-	-	-	-	VCOM_HV	VGHL_LV[1:0]	
	0	1	-	-	VDH[5:0]					
	0	1	-	-	VDL[5:0]					
	0	1	-	-	VDHY[5:0]					

VDS_EN: Source power selection

- 0: External source power from VDH/VDL pins
- 1: Internal DC/DC function for generating VDH/VDL

VDG_EN: Gate power selection

- 0: External gate power from VGH/VGL pins
- 1: Internal DC/DC function for generating VGH/VGL

VCOM_HV: VCOM Voltage Level

- 0: VCOMH=VDH+VCOMDC, VCOML=VHL+VCOMDC
- 1: VCOML=VGH, VCOML=VGL

VGHL_LV [1:0]: VGH / VGL Voltage Level selection

VGHL_LV	VGHL Voltage Level
00(Default)	VGH=16V, VGL= -16V
01	VGH=15V, VGL= -15V
10	VGH=14V, VGL= -14V
11	VGH=13V, VGL= -13V

VDH [5:0]: Internal VDH power selection for B/W pixel. (Default value: 100110b)

VDH	VDH_V	VDH	VDH_V
000000	2.4V
000001	2.6V	100110	10.0V
000010	2.8V	100111	10.2V
000011	3.0V	101000	10.4V
000100	3.2V	101001	10.6V
000101	3.4V	101010	10.8V
000110	3.6V	101011	11.0V
000111	3.8V	(others)	11.0V

VDL [5:0]: Internal VDL power selection for B/W pixel. (Default value: 100110b)

VDL	VDL_V	VDL	VDL_V
000000	-2.4V
000001	-2.6V	100110	-10.0V
000010	-2.8V	100111	-10.2V
000011	-3.0V	101000	-10.4V
000100	-3.2V	101001	-10.6V
000101	-3.4V	101010	-10.8V
000110	-3.6V	101011	-11.0V
000111	-3.8V	(others)	-11.0V

VDHY [5:0]: Internal VDHY power selection for Yellow pixel. (Default value: 000011b)

VDHY	VDHY_V	VDHY	VDHY_V
000000	2.4V
000001	2.6V	100110	10.0V
000010	2.8V	100111	10.2V
000011	3.0V	101000	10.4V
000100	3.2V	101001	10.6V
000101	3.4V	101010	10.8V
000110	3.6V	101011	11.0V
000111	3.8V	(others)	11.0V

(3) Power OFF (PWR) (R02H)

Action	W/R	C/D	D7	D6	D5	D4	D3	D2	D1	D0
Turning OFF the power	0	0	0	0	0	0	0	0	1	0

After the Power Off command, the driver will power off following the Power Off Sequence. This command will turn off the charge pump, T-CON, source driver, gate driver, VCOM, and temperature sensor, but register data will be kept until VDD becomes OFF. Source Driver output and VCOM will remain as the previous condition, which may have 2 conditions: 0V or floating.

(4) Power OFF Sequence Setting (R03H)

Action	W/R	C/D	D7	D6	D5	D4	D3	D2	D1	D0
Setting Power OFF sequence	0	0	0	0	0	0	0	0	1	1
	0	1	-	-	T_VDS_OFF[1:0]		-	-	-	-

T_VDS_OFF [1:0]: Power OFF Sequence of VDH and VDL

00b:1 frame (Default) 01b:2 frames 10b: 3 frames 11b:4 frames

(5) Power ON (PON) (R04H)

Action	W/R	C/D	D7	D6	D5	D4	D3	D2	D1	D0
Turning ON the Power	0	0	0	0	0	0	0	1	0	0

After the Power ON command, the driver will be powered ON following the Power ON Sequence. Refer to the Power ON Sequence section. In the sequence, the temperature sensor will be activated for one-time sensing before enabling the booster.

(6) Power ON Measure (PMES) (R05H)

Action	W/R	C/D	D7	D6	D5	D4	D3	D2	D1	D0
Power ON Measure	0	0	0	0	0	0	0	1	0	1

This command enables the internal bandgap that will be cleared by the next POF.

(7) Booster Soft Start (BTST) (R06H)

Action	W/R	C/D	D7	D6	D5	D4	D3	D2	D1	D0
Starting Data Transmission	0	0	0	0	0	0	0	1	1	0
	0	1	BT_PHA7	BT_PHA6	BT_PHA5	BT_PHA4	BT_PHA3	BT_PHA2	BT_PHA1	BT_PHA0
	0	1	BT_PHB7	BT_PHB6	BT_PHB5	BT_PHB4	BT_PHB3	BT_PHB2	BT_PHB1	BT_PHB0
	0	1	-	-	BT_PHC5	BT_PHC4	BT_PHC3	BT_PHC2	BT_PHC1	BT_PHC0

BTPHA [7:6]: Soft start period of phase A.

00b: 10mS 01b: 20mS 10b: 30mS 11b: 40mS

BTPHA [5:3]: Driving strength of phase A.

000b: strength 1 001b: strength 2 **010b: strength 3** 011b: strength4
100b: strength 5 101b: strength 6 110b: strength 7 111b: strength 8 (strongest)

BTPHA [2:0]: Minimum OFF time setting of GDR in phase B

000b: 0.27uS 001b: 0.34uS 010b: 0.40uS 011b: 0.54uS
100b: 0.80uS 101b: 1.54uS 110b: 3.34uS **111b: 6.58uS**

BTPHB [7:6]: Soft start period of phase B.

00b: 10mS 01b: 20mS 10b: 30mS 11b: 40mS

BTPHB [5:3]: Driving strength of phase B

000b: strength 1 001b: strength 2 **010b: strength 3** 011b: strength4
100b: strength 5 101b: strength 6 110b: strength 7 111b: strength 8 (strongest)

BTPHB [2:0]: Minimum OFF time setting of GDR in phase B

000b: 0.27uS 001b: 0.34uS 010b: 0.40uS 011b: 0.54uS
100b: 0.80uS 101b: 1.54uS 110b: 3.34uS **111b: 6.58uS**

BTPHC [5:3]: Driving strength of phase C

000b: strength 1 001b: strength 2 **010b: strength 3** 011b: strength4
100b: strength 5 101b: strength 6 110b: strength 7 111b: strength 8 (strongest)

BTPHC [2:0]: Minimum OFF time setting of GDR in phase C

000b: 0.27uS 001b: 0.34uS 010b: 0.40uS 011b: 0.54uS
100b: 0.80uS 101b: 1.54uS 110b: 3.34uS **111b: 6.58uS**

(8) Deep Sleep (DSLPL) (R07H)

Action	W/R	C/D	D7	D6	D5	D4	D3	D2	D1	D0
Deep Sleep	0	0	0	0	0	0	0	1	1	1
	0	1	1	0	1	0	0	1	0	1

After this command is transmitted, the chip would enter the deep-sleep mode to save power.

The deep sleep mode would return to standby by hardware reset.

The only one parameter is a check code, the command would be executed if check code = 0xA5.

(9) Data Start Transmission 1 (R10H)

Action	W/R	C/D	D7	D6	D5	D4	D3	D2	D1	D0
Starting Data Transmission	0	0	0	0	0	1	0	0	0	0
	0	1	Pixel1	Pixel2	Pixel3	Pixel4	Pixel5	Pixel6	Pixel7	Pixel8
	0	1
	0	1	Pixel(n-7)	Pixel(n-6)	Pixel(n-5)	Pixel(n-4)	Pixel(n-3)	Pixel(n-2)	Pixel(n-1)	Pixel(n)

This command starts transmitting data and writes the data to SRAM. To complete data transmission, command DSP (Data Transmission Stop) must be issued. Then the chip will start to send data/VCOM for panel.

In B/W mode, this command writes "OLD" data to SRAM.

In B/W/Yellow mode, this command writes "B/W" data to SRAM.

In Program mode, this command writes "OTP" data to SRAM for programming.

(10) Data Stop (R11H)

Action	W/R	C/D	D7	D6	D5	D4	D3	D2	D1	D0
Stopping Data Transmission	0	0	0	0	0	1	0	0	0	1
	1	1	Data_flag	-	-	-	-	-	-	-

To stop data transmission, this command must be issued to check the data_flag.

Data_flag: Data flag of receiving user data.

0: Driver didn't receive all the data.

1: Driver has already received all the one-frame data (DTM1 and DTM2).

After "Data Start" (R10H) or "Data Stop" (R11H) commands and when data_flag=1, the refreshing of the panel starts and the BUSY signal will become "0".

(11) Display Refresh Command (R12H)

Action	W/R	C/D	D7	D6	D5	D4	D3	D2	D1	D0
Refreshing the Display	0	0	0	0	0	1	0	0	1	0

After this command is issued, the driver will refresh the display (data/VCOM) according to SRAM data and LUT. After Display Refresh command, BUSY signal will become "0" and the refreshing of the panel starts.

(12) Data Start Transmission 2 (DTM2) (R13H)

Action	W/R	C/D	D7	D6	D5	D4	D3	D2	D1	D0
Starting Data Transmission	0	0	0	0	0	1	0	0	1	1
	0	1	Pixel1	Pixel2	Pixel3	Pixel4	Pixel5	Pixel6	Pixel7	Pixel8
	0	1
	0	1	Pixel(n-7)	Pixel(n-6)	Pixel(n-5)	Pixel(n-4)	Pixel(n-3)	Pixel(n-2)	Pixel(n-1)	Pixel(n)

This command starts transmitting data and writes the data to SRAM. To complete data transmission, command DSP (Data Transmission Stop) must be issued. Then the chip will start to send data/VCOM for panel.

In B/W mode, this command writes "NEW" data to SRAM.

In B/W/Yellow mode, this command writes "YELLOW" data to SRAM.

(13) VCOM LUT (LUTC) (R20H)

This command builds the Look-up Table for VCOM.

(14) W2W LUT (LUTWW) (R21H)

This command builds the Look-up Table for White-to-White.

(15) B2W LUT (LUTBW/LUTR) (R22H)

This command builds the Look-up Table for Black-to-White.

(16) W2B LUT (LUTWB/LUTW) (R23H)

This command builds the Look-up Table for White-to-Black.

(17) B2B LUT (LUTBB / LUTB) (R24H)

This command builds the Look-up Table for Black-to-Black.

(18) PLL Control (PLL) (R30H)

Action	W/R	C/D	D7	D6	D5	D4	D3	D2	D1	D0
Controlling PLL	0	0	0	0	1	1	0	0	0	0
	0	1	-	-	M[2:0]			N[2:0]		

This command controls the PLL clock frequency.

The PLL structure must support the following frame rates:

M	N	Frame Rate	M	N	Frame Rate	M	N	Frame Rate	M	N	Frame Rate
1	1	29 Hz	3	1	86 Hz	5	1	150 Hz	7	1	200 Hz
	2	14 Hz		2	43 Hz		2	72 Hz		2	100 Hz
	3	10 Hz		3	29 Hz		3	48 Hz		3	67 Hz
	4	7 Hz		4	21 Hz		4	36 Hz		4	50 Hz (Default)
	5	6 Hz		5	17 Hz		5	29 Hz		5	40 Hz
	6	5 Hz		6	14 Hz		6	24 Hz		6	33 Hz
	7	4 Hz		7	12 Hz		7	20 Hz		7	29 Hz
2	1	57 Hz	4	1	114 Hz	6	1	171 Hz			
	2	29 Hz		2	57 Hz		2	86 Hz			
	3	19 Hz		3	38 Hz		3	57 Hz			
	4	14 Hz		4	29 Hz		4	43 Hz			
	5	11 Hz		5	23 Hz		5	34 Hz			
	6	10 Hz		6	19 Hz		6	29 Hz			
	7	8 Hz		7	16 Hz		7	24 Hz			

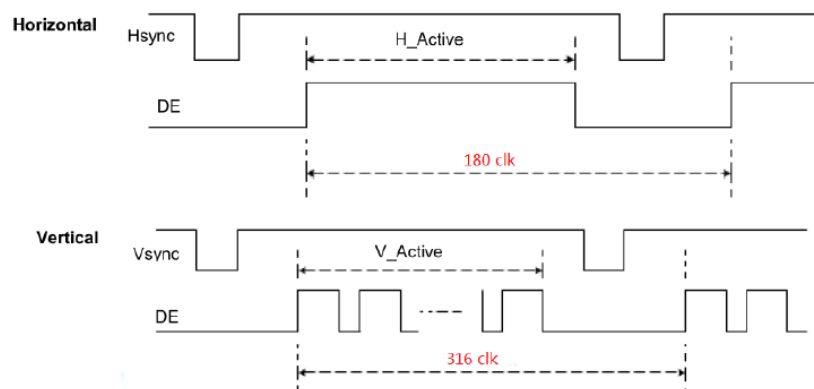

(19) Temperature Sensor Calibration (TSC) (R40H)

Action	W/R	C/D	D7	D6	D5	D4	D3	D2	D1	D0
Sensing Temperature	0	0	0	1	0	0	0	0	0	0
	1	1	D10/TS7	D9/TS6	D8/TS5	D7/TS4	D6/TS3	D5/TS2	D4/TS1	D3/TS0
	1	1	D2	D1	D0	-	-	-	-	-

This command reads the temperature sensed by the temperature sensor.

TS [7:0]: When TSE (R41h) is set to 0, this command reads the internal temperature sensor value.

D [10:0]: When TSE (R41h) is set to 1, this command reads the external LM75 temperature sensor value.

TS[7:0]/D[10:3]	Temperature (°C)	TS[7:0]/D[10:3]	Temperature (°C)	TS[7:0]/D[10:3]	Temperature (°C)
1110_0111	-25	0000_0000	0	0001_1001	25
1110_1000	-24	0000_0001	1	0001_1010	26
1110_1001	-23	0000_0010	2	0001_1011	27
1110_1010	-22	0000_0011	3	0001_1100	28
1110_1011	-21	0000_0100	4	0001_1101	29
1110_1100	-20	0000_0101	5	0001_1110	30
1110_1101	-19	0000_0110	6	0001_1111	31
1110_1110	-18	0000_0111	7	0010_0000	32
1110_1111	-17	0000_1000	8	0010_0001	33
1111_0000	-16	0000_1001	9	0010_0010	34
1111_0001	-15	0000_1010	10	0010_0011	35
1111_0010	-14	0000_1011	11	0010_0100	36
1111_0011	-13	0000_1100	12	0010_0101	37
1111_0100	-12	0000_1101	13	0010_0110	38
1111_0101	-11	0000_1110	14	0010_0111	39
1111_0110	-10	0000_1111	15	0010_1000	40
1111_0111	-9	0001_0000	16	0010_1001	41
1111_1000	-8	0001_0001	17	0010_1010	42
1111_1001	-7	0001_0010	18	0010_1011	43
1111_1010	-6	0001_0011	19	0010_1100	44
1111_1011	-5	0001_0100	20	0010_1101	45
1111_1100	-4	0001_0101	21	0010_1110	46
1111_1101	-3	0001_0110	22	0010_1111	47
1111_1110	-2	0001_0111	23	0011_0000	48
1111_1111	-1	0001_1000	24	0011_0001	49

(20) Temperature Sensor Enable (R41H)

Action	W/R	C/D	D7	D6	D5	D4	D3	D2	D1	D0
Enable Temperature Sensor/Offset	0	0	0	1	0	0	0	0	0	1
	0	1	TSE	-	-	-	TO[3:0]			

This command selects the Internal and External temperature sensor.

TSE: Internal temperature sensor switch

0: Enable (Default) 1: Disable; using external sensor.

TO[3:0] Temperature offset.

TO[3:0]	Calculation	TO[3:0]	Calculation
0000 b	0	1000	-8
0001	1	1001	-7
0010	2	1010	-6
...
0110	6	1110	-2
0111	7	1111	-1

(21) Temperature Sensor Write (TSW) (R42H)

Action	W/R	C/D	D7	D6	D5	D4	D3	D2	D1	D0
Write External Temperature Sensor	0	0	0	1	0	0	0	0	1	0
	0	1	WATTR[7:0]							
	0	1	WMSB[7:0]							
	0	0	WLSB[7:0]							

This command reads the temperature sensed by the temperature sensor.

WATTR: D[7:6] I²C Write Byte Number

00b: 1 byte (head byte only)

01b: 2 bytes (head byte + pointer)

10b: 3 bytes (head byte + pointer + 1st parameter)

11b: 4 bytes (head byte + pointer + 1st parameter + 2nd parameter)

D[5:3]: User-defined address bits (A2, A1, A0)

D[2:0]: Pointer setting

WMSB[7:0]: MSByte of write-data to external temperature sensor.

WLSB[7:0]: LSByte of write-data to external temperature sensor.

(22) Temperature Sensor Read (TSR) (R43H)

Action	W/R	C/D	D7	D6	D5	D4	D3	D2	D1	D0
Read External Temperature Sensor	0	0	0	1	0	0	0	0	1	1
	1	1	RMSB[7:0]							
	1	1	RLSB[7:0]							

This command reads the temperature sensed by the temperature sensor.

RMSB[7:0]: MSByte read data from external temperature sensor.

RLSB[7:0]: LSByte read data from external temperature sensor.

(23) VCOM and Data Interval Setting (CDI) (R50H)

Action	W/R	C/D	D7	D6	D5	D4	D3	D2	D1	D0
Set Interval Between VCOM and Data	0	0	0	1	0	1	0	0	0	0
	0	1	VBD[1:0]		DDX[1:0]		CDI[3:0]			

This command indicates the interval of VCOM and data output. When setting the vertical back porch, the total blanking will be kept (20 H_{SYNC}).

VBD[1:0]: Border data selection

B/W/Yellow mode (BWY=0)

DDX[0]	VBD[1:0]	LUT	DDX[0]	VBD[1:0]	LUT
0	00	Floating	1 (Default)	00	LUTB
	01	LUTR		01	LUTW
	10	LUTW		10	LUTR
	11	LUTB		11	Floating

B/W mode (BWY=1)

DDX[0]	VBD[1:0]	LUT	DDX[0]	VBD[1:0]	LUT
0	00	Floating	1 (Default)	00	Floating
	01	LUTBW (1 → 0)		01	LUTWB (1 → 0)
	10	LUTWB (0 → 1)		10	LUTBW (0 → 1)
	11	Floating		11	Floating

DDX[1:0]: Display polarity.

DDX[1] for YELLOW data, DDX[0] for BW data on the B/W/Yellow mode.

DDX[0] for B/W mode.

B/W/Yellow mode (BWY=0)

DDX[1:0]	Data {Yellow, B/W}	LUT	DDX[1:0]	Data {Yellow, B/W}	LUT
00	00	LUTW	10	00	LUTR
	01	LUTB		01	LUTR
	10	LUTR		10	LUTW
	11	LUTR		11	LUTB
01 (Default)	00	LUTB	11	00	LUTR
	01	LUTW		01	LUTR
	10	LUTR		10	LUTB
	11	LUTR		11	LUTW

B/W mode (BWY=1)

DDX[0]	Data {New, Old}	LUT	DDX[0]	Data {New, Old}	LUT
0	00	LUTWW (0 → 0)	1(Default)	00	LUTBB (0 → 0)
	01	LUTBW (1 → 0)		01	LUTWB (0 → 1)
	10	LUTWB (0 → 1)		10	LUTBW (1 → 0)
	11	LUTBB (1 → 1)		11	LUTWW (1 → 1)

CDI[3:0]: VCOM and Data Interval

CDI[3:0]	VCOM and Data Interval	CDI[3:0]	VCOM and Data Interval
0000 b	17 H _{SYNC}	0110	11
0001	16	0111	10 (Default)
0010	15
0011	14	1101	4
0100	13	1110	3
0101	12	1111	2

(24) Low Power Detection (LPD) (R51H)

Action	W/R	C/D	D7	D6	D5	D4	D3	D2	D1	D0
Detect Low Power	0	0	0	1	0	1	0	0	0	1
	1	1	-	-	-	-	-	-	-	LPD

This command indicates the input power condition. Host can read this flag to learn the condition of the battery.

LPD: Interval Low Power Detection Flag

0: Low Power Input (VDD<2.5V)

1: Normal Status (Default)

(25) TCON Setting (TCON) (R60H)

Action	W/R	C/D	D7	D6	D5	D4	D3	D2	D1	D0
Set Gate/Source Non-Overlap Period	0	0	0	1	1	0	0	0	0	0
	0	1	S2G[3:0]				G2S[3:0]			

This command defines the non-overlap period of Gate and Source.

S2G[3:0] or G2S[3:0]: Source to Gate / Gate to Source Non-overlap Period

S2G[3:0] or G2S[3:0]	Period	S2G[3:0] or G2S[3:0]	Period
0000b	4
0001	8	1011	48
0010	12 (Default)	1100	52
0011	16	1101	56
0100	20	1110	60
0101	24	1111	64

Period = 660 nS.

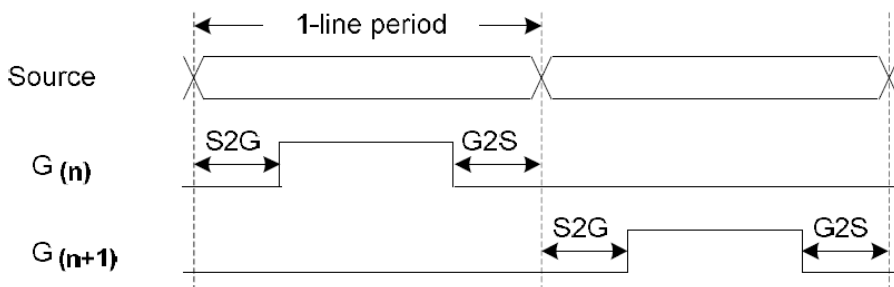
(26) Resolution Setting (TRES) (R61H)

Action	W/R	C/D	D7	D6	D5	D4	D3	D2	D1	D0
Set Display Resolution	0	0	0	1	1	0	0	0	0	1
	0	1	HRES[7:3]					0	0	0
	0	1	-	-	-	-	-	-	-	VRES[8]
	0	0	VRES[7:0]							

This command defines the alternative resolution and this setting is of higher priority than the RES[1:0] in R00H (PSR).

HRES[7:3]: Horizontal Display Resolution

VRES[8:0]: Vertical Display Resolution

Active Channel Calculation:

GD: First active gate = G0 (Fixed); LAST active gate = VRES[8:0]-1

SD: First active source = S0 (Fixed); LAST active source = HRES[7:3]*8-1

(27) Get Status (FLG) (R71H)

Action	W/R	C/D	D7	D6	D5	D4	D3	D2	D1	D0
Read Flags	0	0	0	1	1	1	0	0	0	1
	1	1	-	PTL_flag	I ² C_ERR	I ² C_BUSY	data_flag	PON	POF	BUSY

This command reads the IC status.

PTL_FLAG: Partial display status (high: partial mode)

I²C_ERR: I²C master error status

I²C_BUSY: I²C master BUSY status (low active)

data_flag: Driver has already received all the one frame data

PON: Power ON status

POF: Power OFF status

BUSY: Driver busy status (low active)

(28) Auto Measure VCOM (AMV) (R80H)

Action	W/R	C/D	D7	D6	D5	D4	D3	D2	D1	D0
Automatically Measure VCOM	0	0	1	0	0	0	0	0	0	0
	0	1	-	-	AMVT[1:0]		XON	AMVS	AMV	AMVE

This command reads the IC status.

AMVT[1:0]: Auto Measure VCOM Time

00b: 3s 01b: 5s (Default)

10b: 8s 11b:10s

XON: All Gate ON of AMV

0: Gate normally scans during Auto Measure VCOM period. (Default)

1: All Gate ON during Auto Measure VCOM period.

AMVS: Source Output of AMV

0: Source output 0V during Auto Measure VCOM period. (Default)

1: Source output V_{DHY} during Auto Measure VCOM period.

AMV: Analog Signal

0: Get VCOM value with the VV command (R81h) (Default)

1: Get VCOM value in analog signal. (external analog to digital converter)

AMVE: Auto Measure VCOM Enable (Disable)

0: No effect

1: Trigger Auto VCOM sensing



(29) VCOM Value (VV) (R81H)

Action	W/R	C/D	D7	D6	D5	D4	D3	D2	D1	D0
Automatically Measure VCOM	0	0	1	0	0	0	0	0	0	1
	1	1	-	-	VV[5:0]					

This command gets the VCOM value.

VV[5:0]: VCOM Value Output

VV[5:0]	VCOM Value
00 0000b	-0.10 V
00 0001b	-0.15 V
00 0010b	-0.20 V
:	:
11 1010b	-3.00 V

(30) VCOM-DC Setting (VDCS) (R82H)

Action	W/R	C/D	D7	D6	D5	D4	D3	D2	D1	D0
Set VCM_DC	0	0	1	0	0	0	0	0	1	0
	0	1	-	-	VDCS[5:0]					

This command sets VCOM_DC value.

VDCS[5:0]: VCOM-DC Setting

VDCS[5:0]	VCOM_DC Value
00 0000b	-0.10 V (Default)
00 0001b	-0.15 V
00 0010b	-0.20 V
:	:
11 1010b	-3.00 V

(31) Partial Window (PTL) (R90H)

Action	W/R	C/D	D7	D6	D5	D4	D3	D2	D1	D0
Set Partial Window	0	0	1	0	0	1	0	0	0	0
	0	1	HRST[7:3]					0	0	0
	0	1	HYELLOW[7:3]					1	1	1
	0	1	-	-	-	-	-	-	-	VRST[8]
	0	1	VRST[7:0]							
	0	1	-	-	-	-	-	-	-	VYELLOW[8]
	0	1	VYELLOW[7:0]							
	0	1	-	-	-	-	-	-	-	PT_SCAN

This command sets partial window.

HRST[7:3]: Horizontal start channel bank. (value 00h~13h)

HYELLOW[7:3]: Horizontal end channel bank. (value 00h~13h). HYELLOW must be greater than HRST.

VRST[8:0]: Vertical start line. (value 000h~127h)

VYELLOW[8:0]: Vertical end line. (value 000h~127h). VYELLOW must be greater than VRST.

PT_SCAN: 0: Gates scan only inside of the partial window.

1: Gates scan both inside and outside of the partial window. (default)

(32) Partial In (PTIN) (R91H)

Action	W/R	C/D	D7	D6	D5	D4	D3	D2	D1	D0
Partial In	0	0	1	0	0	1	0	0	0	1

This command makes the display enter partial mode.

(33) Partial Out (PTOUT) (R92H)

Action	W/R	C/D	D7	D6	D5	D4	D3	D2	D1	D0
Partial Out	0	0	1	0	0	1	0	0	1	0

This command makes the display exit partial mode and enter normal mode.

(34) Program Mode (PGM) (RA0H)

Action	W/R	C/D	D7	D6	D5	D4	D3	D2	D1	D0
Enter Program Mode	0	0	1	0	1	0	0	0	0	0
	0	1	1	0	1	0	0	1	0	1

After this command is issued, the chip will enter the program mode.

The mode would return to standby by hardware reset.

The only one parameter is a check code, the command would be executed if check code = 0xA5.

(35) Active Program Mode (APG) (RA1H)

Action	W/R	C/D	D7	D6	D5	D4	D3	D2	D1	D0
Active Program OTP	0	0	1	0	1	0	0	0	0	1

After this command is transmitted, the programming state machine will be activated. The BUSY flag will fall to 0 until the programming is completed.

(36) Read OTP Data (ROTP) (RA2H)

Action	W/R	C/D	D7	D6	D5	D4	D3	D2	D1	D0
Read OTP Data for Check	0	0	1	0	1	0	0	0	1	0
	1	1	Dummy							
	1	1	The data of address 0x000 in the OTP							
	1	1	The data of address 0x001 in the OTP							
	1	1	..							
	1	1	The data of address (n-1) in the OTP							
	1	1	The data of address (n) in the OTP							

This command is used for reading the content of OTP for checking the data of programming.

The value of (n) is dependent on the amount of programmed data, the max address = 0xFFFF.

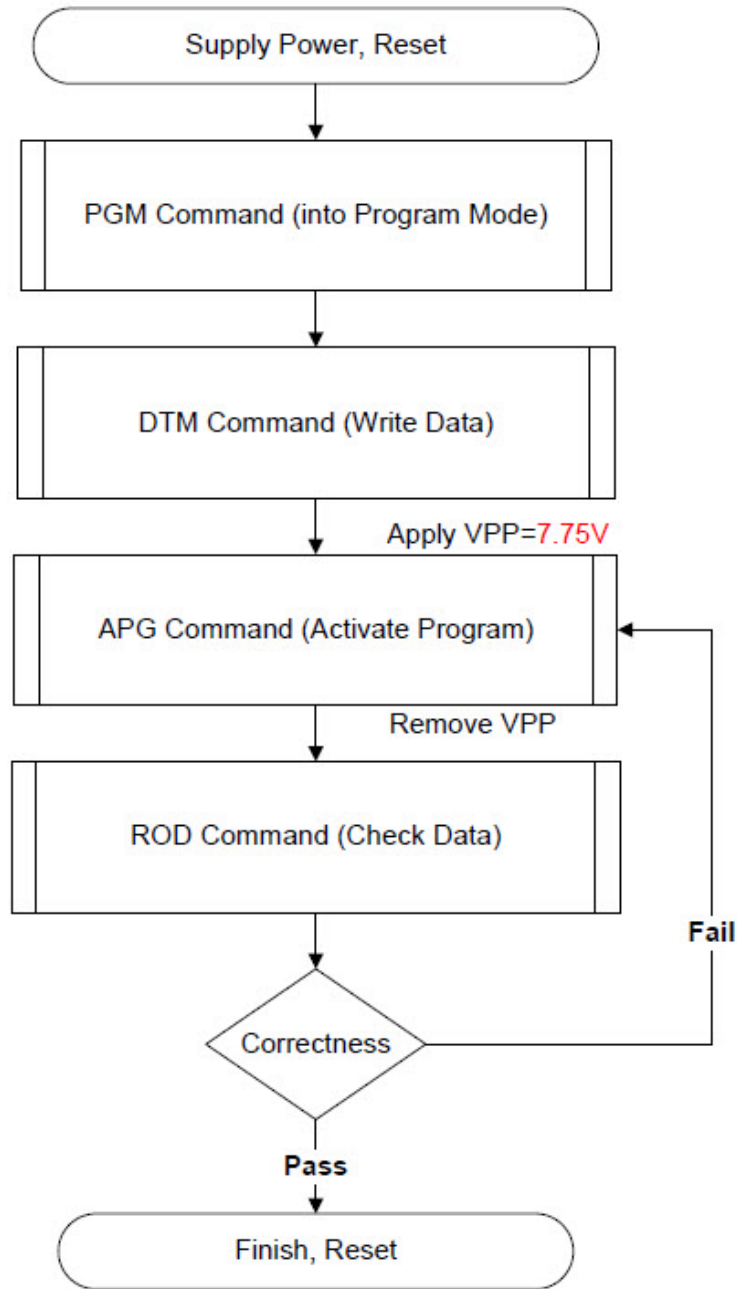

The Sequence of Programming OTP

(37) Power Saving (PWS) (RE3H)

Action	W/R	C/D	D7	D6	D5	D4	D3	D2	D1	D0
Power Saving for VCOM & Source	0	0	1	1	1	0	0	0	1	1
	0	1	VCOM_W[3:0]				SD_W[3:0]			

This command is set for saving power during fresh period. If the output voltage of VCOM / Source is from negative to positive or from positive to negative, the power saving mechanism will be activated. The active period width is defined by the following two parameters.



VCOM_W[3:0]: VCOM power saving width (unit = line period)

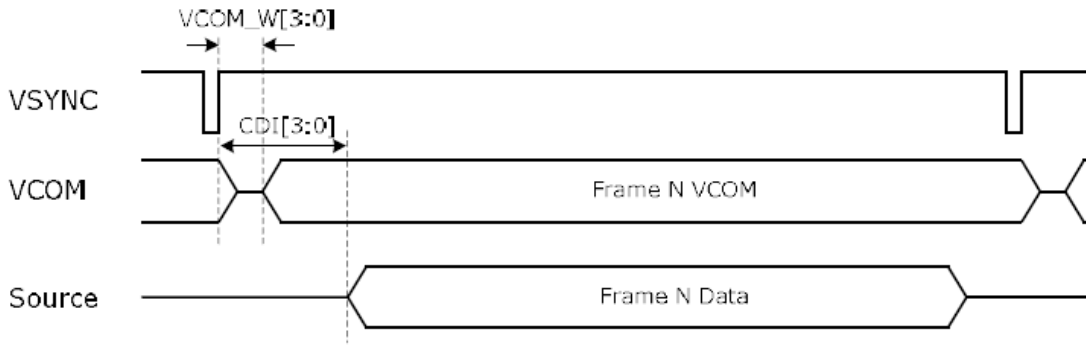

SD_W[3:0]: Source power saving width (unit = 660nS)

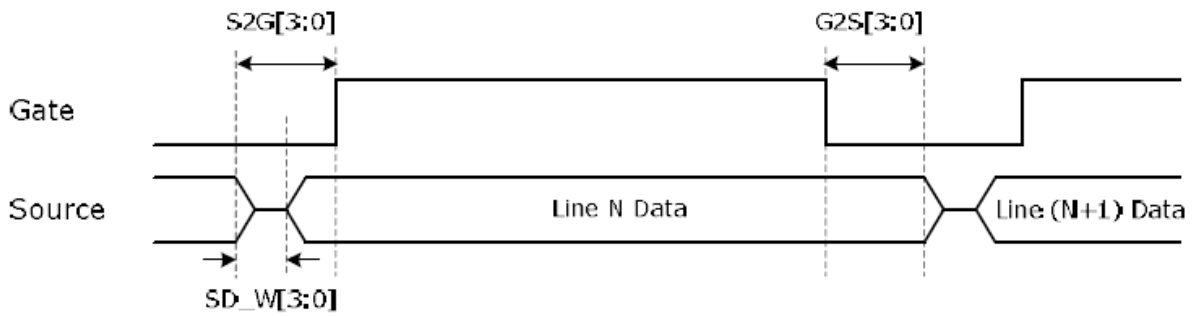

7. Electrical Characteristics

7.1. Absolute Maximum Rating

Parameter	Symbol	Rating	Unit
Logic Supply Voltage	V_{CI}	-0.3 to +6.0	V
Logic Input Voltage	V_{IN}	-0.3 to $V_{CI} + 2.4$	V
Operating Temp. range	T_{OPR}	0 to +40	°C
Storage Temp. range	T_{STG}	-25 to +60	°C
Humidity Range	RH	40~70	%

IMPORTANT: It is recommended that you use a UV protective film when operating the module in direct sunlight.

7.2. Panel DC Characteristics

The following specifications apply for: $V_{SS} = 0V$, $V_{CI} = 3.3V$, $T_a = 25^\circ C$

Parameter	Symbol	Conditions	Min	Typ	Max	Unit
Single ground	V_{SS}	-	-	0	-	V
Logic Supply Voltage	V_{CI}	-	2.3	3.3	3.6	V
High Level Input Voltage	V_{IH}	Digital Input Pins	$0.7V_{CI}$	-	V_{CI}	V
Low Level Input Voltage	V_{IL}	Digital Input Pins	0	-	$0.3V_{CI}$	V
High Level Output Voltage	V_{OH}	Digital Input Pins, $I_{OH} = 400\mu A$	$V_{CI} - 0.4$	-	-	V
Low Level Output Voltage	V_{OL}	Digital Input Pins, $I_{OL} = -400\mu A$	0	-	0.4	V
Image Update Current	I_{UPDATE}	-	-	8	10	mA
Standby Panel Current	$I_{STANDBY}$	-	-	-	5	μA
Power Panel (Update)	P_{UPDATE}	-	-	26.4	40	mW
Standby Power Panel	P_{STBY}	-	-	-	0.0165	mW
Operating Temperature	-	-	0	-	40	°C
Storage Temperature	-	-	-25	-	60	°C
Image update Time at 25°C	-	-	-	12	15	sec
Deep sleep mode current	I_{VCI}	DC/DC off No clock No input load Ram data not retain	-	2	5	μA
Sleep mode current	I_{VCI}	DC/DC off No clock No input load Ram data retain	-	35	50	μA

The typical power consumption is measured with the following pattern transition: from horizontal 2 gray scale pattern to vertical 2 gray scale pattern, shown below.

Note: The standby power is the consumed power when the panel controller is in standby mode. The listed electrical/optical characteristics are only guaranteed under the controller & waveform provided by Crystalfontz. V_{COM} is recommended to be set in the range of assigned value $\pm 0.1V$.

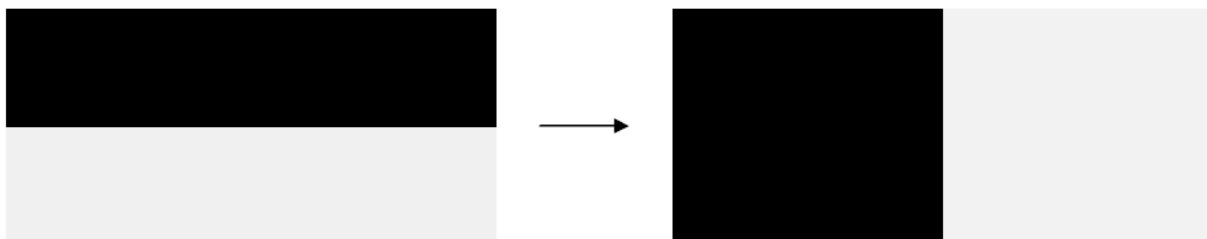

7.3. Panel AC Characteristics

7.3.1. Oscillator Frequency

The following specifications apply for: $V_{SS} = 0V$, $V_{CI} = 3.3V$, $T_a = 25^\circ C$

Parameter	Symbol	Conditions	Min	Typ	Max	Unit
Internal Oscillator Frequency	Fosc	$V_{CI}=2.3$ to $3.6V$	-	1.625	-	MHz

7.3.2. MCU Interface Selection

In this module, there are 4-wire SPI and 3-wire SPI that can communicate with MCU. The MCU interface mode can be set by hardware selection on BS1 pins. When it is "Low", 4-wire SPI is selected. When it is "High", 3-wire SPI (9 bits SPI) is selected.

Pin Name	Data/Command Interface		Control Signal		
	D1	D0	CS#	D/C#	RES#
Bus Interface	SDIN	SCLK	CS#	D/C#	RES#
SPI4	SDIN	SCLK	CS#	L	RES#

Table 7-1: MCU Interface Assignment Under Different Bus Interface Mode

Note: L is connected to V_{SS} . H is connected to V_{CI} .

7.3.3. MCU Serial Interface (4-Wire SPI)

The 4-wire SPI consists of serial clock SCLK, serial data SDIN, D/C#, CS#. In SPI mode, D0 acts as SCLK, D1 acts as SDIN.

Function	CS#	D/C#	SCLK
Write Command	L	L	↑
Write Data	L	H	↑

Table 7-2: Control Pins of 4-Wire Serial Peripheral Interface

Note: ↑stands for rising edge of signal

SDIN is shifted into an 8-bit shift register in the order of D7, D6, ...D0. The data byte in the shift register is written to the Graphic Display Data RAM (RAM) or command register in the same clock. Under serial mode, only write operations are allowed.

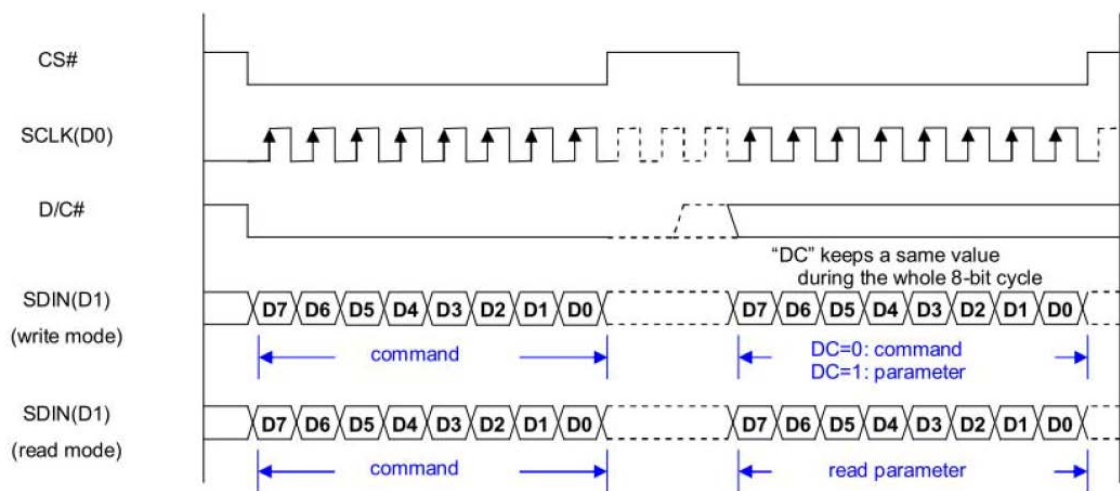

Figure 7-1: Write Procedure in 4-Wire Serial Peripheral Interface Mode



7.3.4. MCU Serial Interface (3-Wire SPI)

The 3-wire serial interface consists of serial clock SCLK, serial data ADIN and CS#.

In 3-wire SPI mode, D0 acts as SCLK, D1 acts as SDIN. The pin D/C# can be connected to an external ground.

The operation is similar to 4-wire serial interface while D/C# pin is not used. There are altogether 9-bits that will be shifted into the shift register on every ninth clock in sequence: D/C# bit, D7 to D0 bit. The D/C# bit (first bit of the sequential data) will determine the following data byte in shift register is written to the Display Data RAM (D/C# bit = 1) or the command register (D/C# bit = 0). Under serial mode, only write operations are allowed.

Function	CS#	D/C#	SCLK
Write Command	L	Tie LOW	↑
Write Data	L	Tie LOW	↑

Table 7-3: Control Pins of 3-Wire Serial Peripheral Interface

Note: ↑stands for rising edge of signal

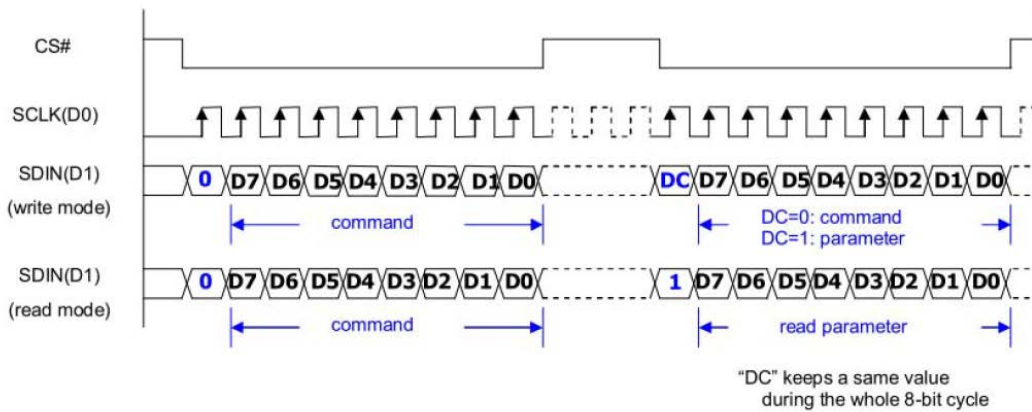
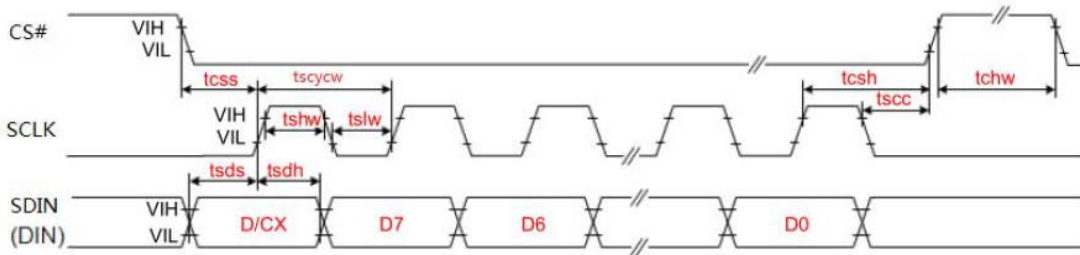

Figure 7-2: Write Procedure in 3-Wire Serial Peripheral Interface Mode



7.3.5. Timing Characteristics of Series Interface



3-wire Serial Interface – Write

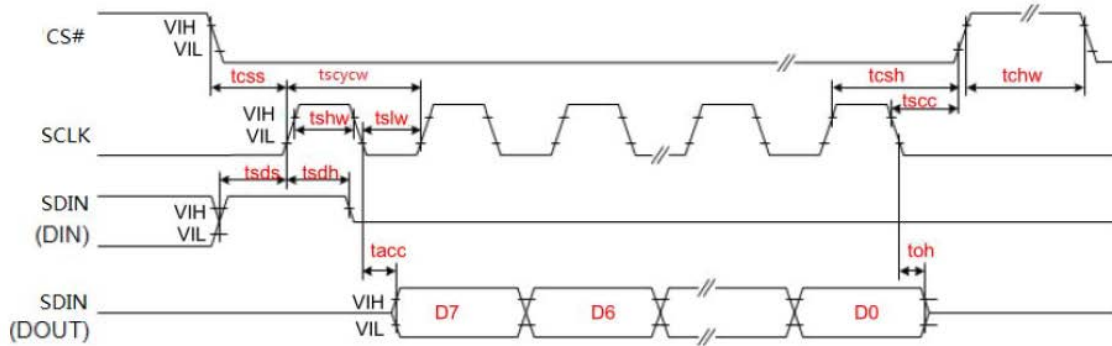

3-wire Serial Interface – Read

Symbol	Signal	Parameter	Min	Typ	Max	Unit
tcss	CS#	Chip Select Setup Time	60	-	-	ns
tsh		Chip Select Hold Time	65	-	-	ns
tsc		Chip Select Setup Time	20	-	-	ns
tch		Chip Select Setup Time	40	-	-	ns
tscycw	SCLK	Serial Clock Cycle (Write)	100	-	-	ns
tshw		SCL "H" Pulse Width (Write)	35	-	-	ns
tslw		SCL "L" Pulse Width (Write)	35	-	-	ns
tscycr		Serial Clock Cycle (Read)	150	-	-	ns
tshr		SCL "H" Pulse Width (Read)	60	-	-	ns
tslr		SCL "L" Pulse Width (Read)	60	-	-	ns
tsds	SDIN (DIN) (DOUT)	Data Setup Time	30	-	-	ns
tsdh		Data Hold Time	30	-	-	ns
tacc		Access Time	-	-	10	ns
toh		Output Disable Time	15	-	-	ns

NOTE: If the module is refreshed within 180 seconds of the last refresh it could cause streaks to display across the screen.

7.4. Power Consumption

Parameter	Symbol	Conditions	TYP	Max	Unit	Remark
Panel Power Consumption During Update	-	25°C	26.4	40	mW	-
Power Consumption in Standby Mode	-	25°C	-	0.0165	mW	-

7.5. Reference Circuit

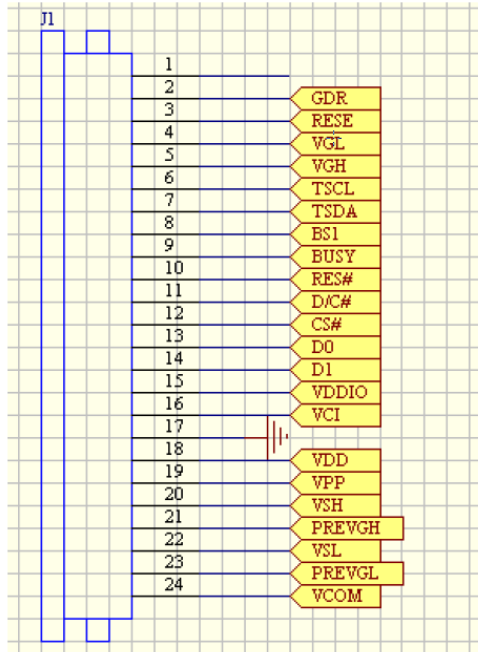

Figure 7-5 (1)

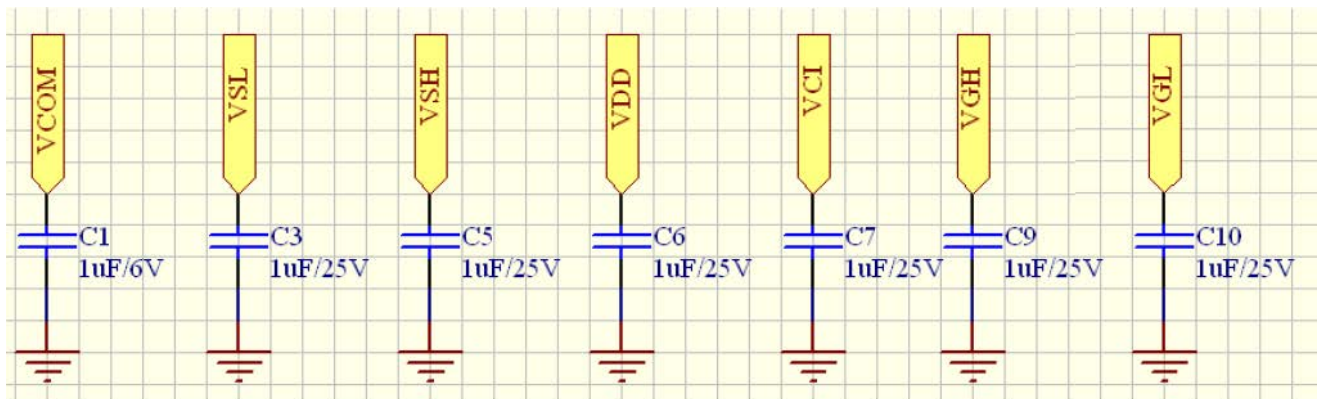

Figure 7-5 (2)

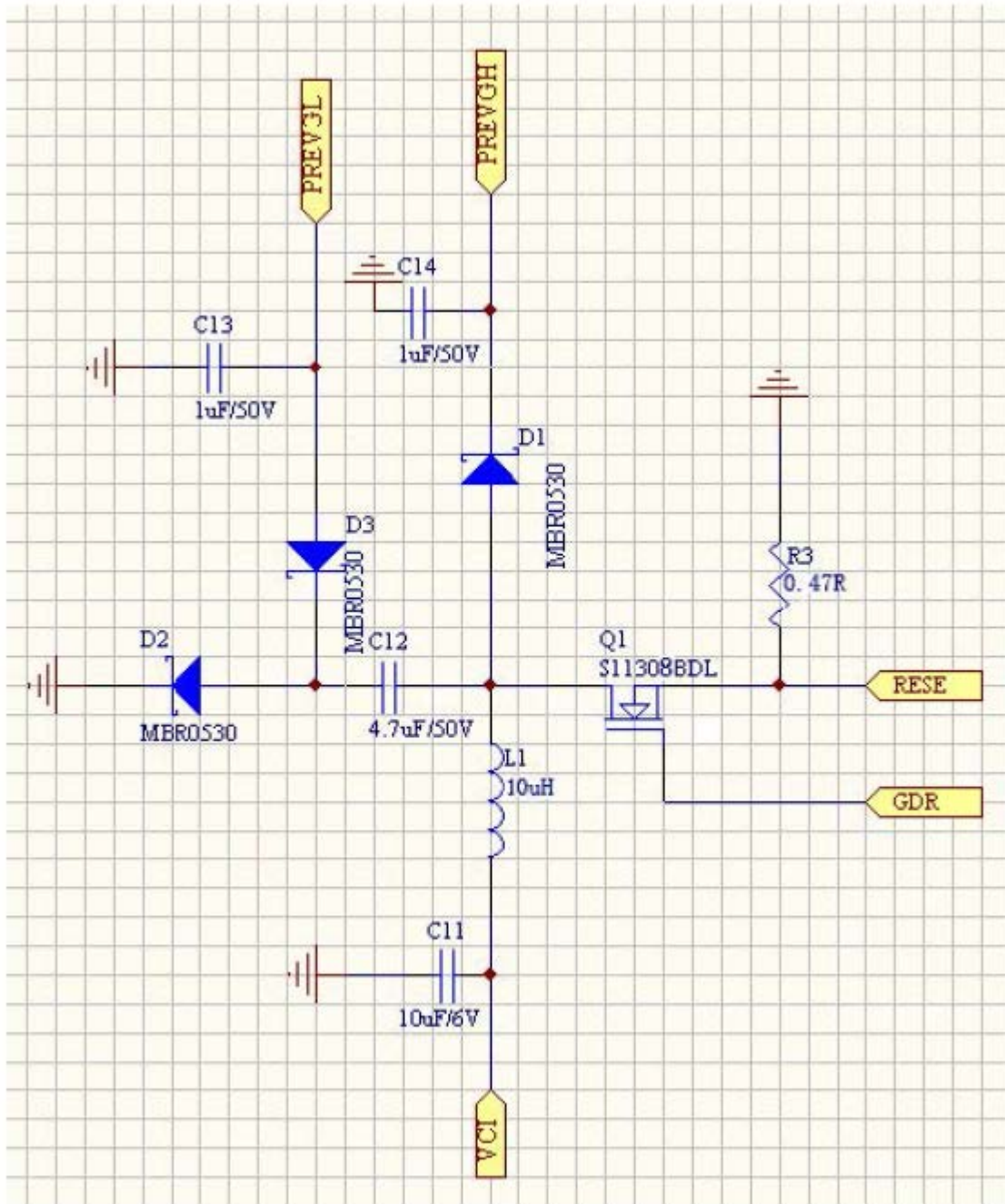

Figure 7-5 (3)

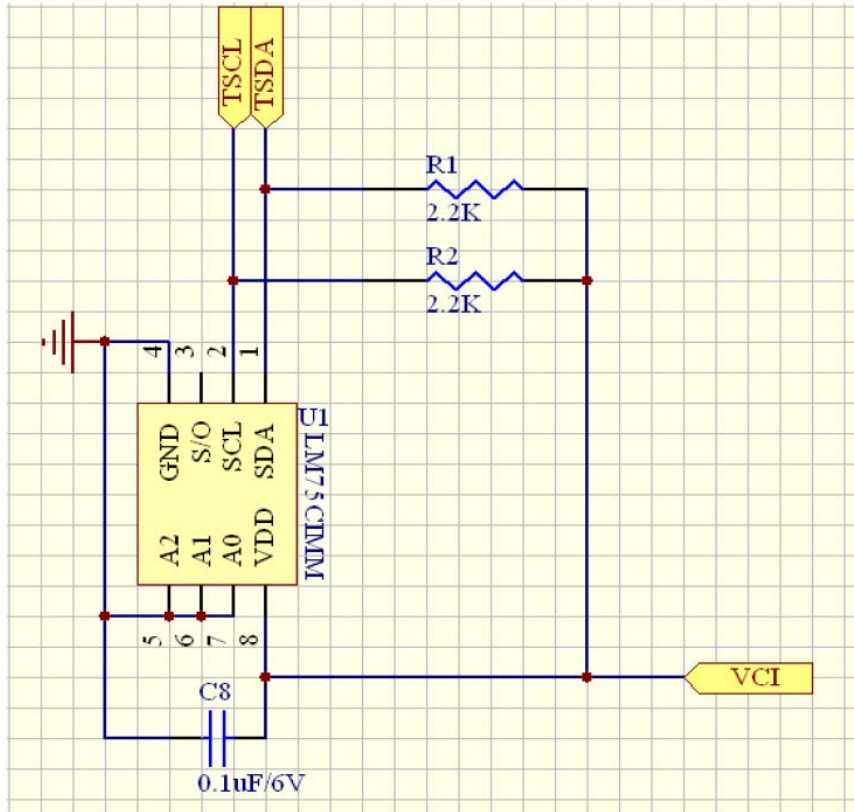
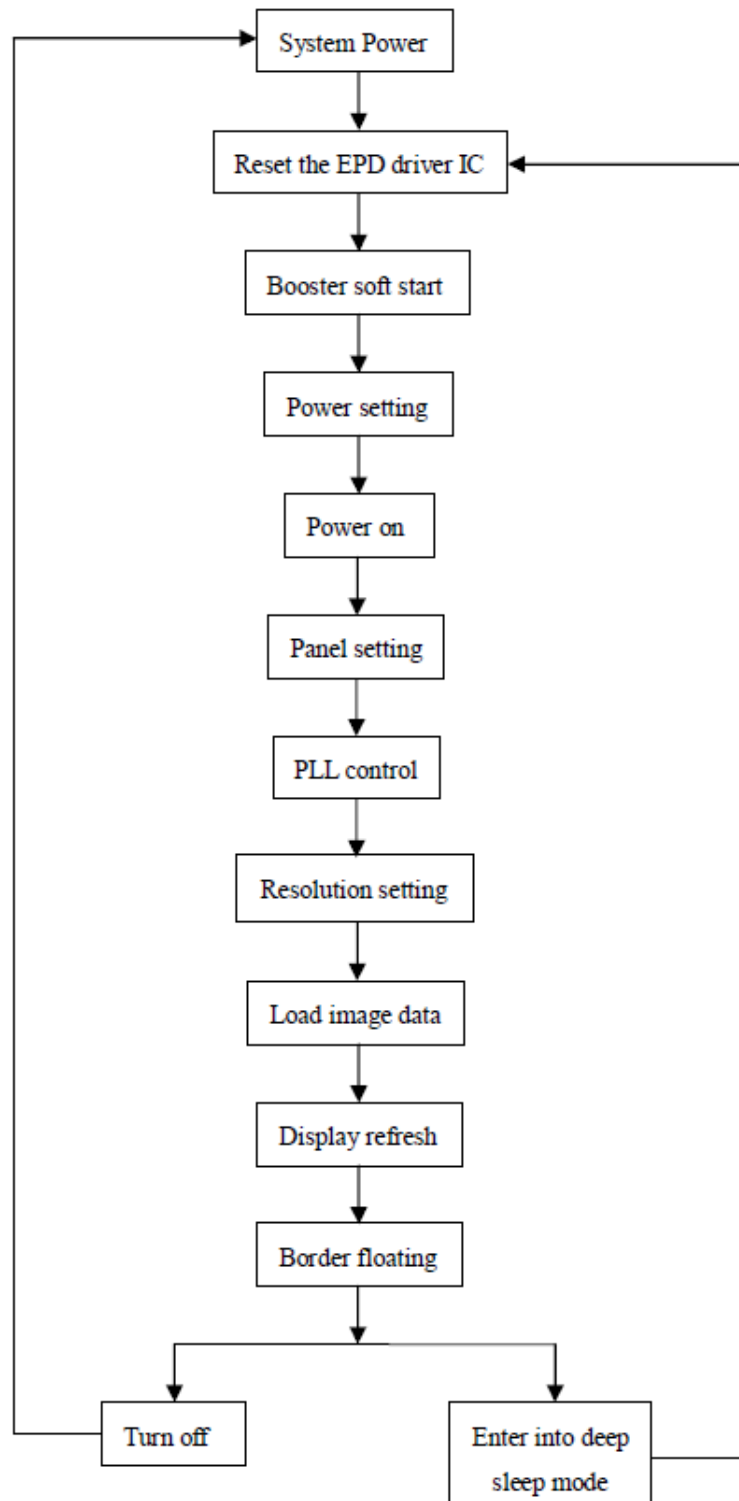

Figure 7-5 (4)

8. Typical Operating Sequence

8.1. Normal Operation Flow

8.1.1. BWY Mode & LUT from Register





8.1.2. BWY Mode & LUT from OTP

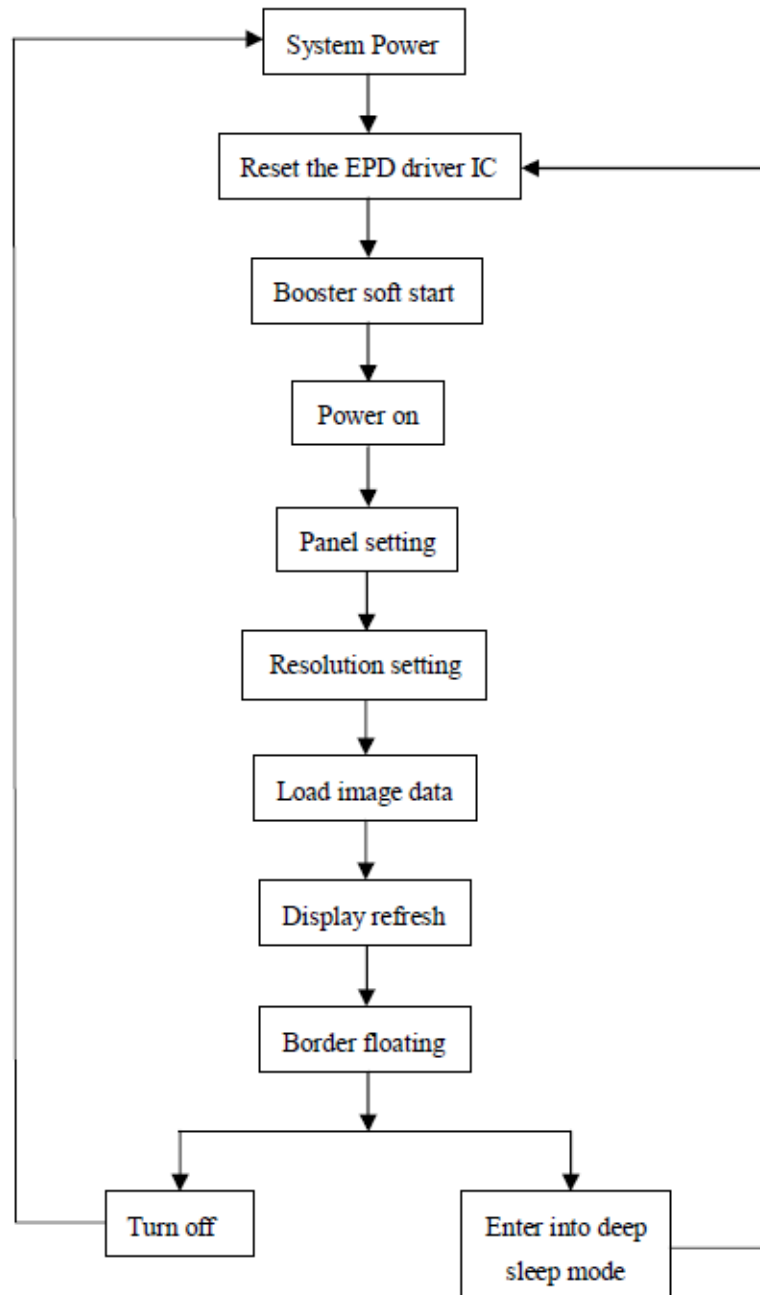



8.2. Reference Program Code

8.2.1. BWY Mode & LUT from Register

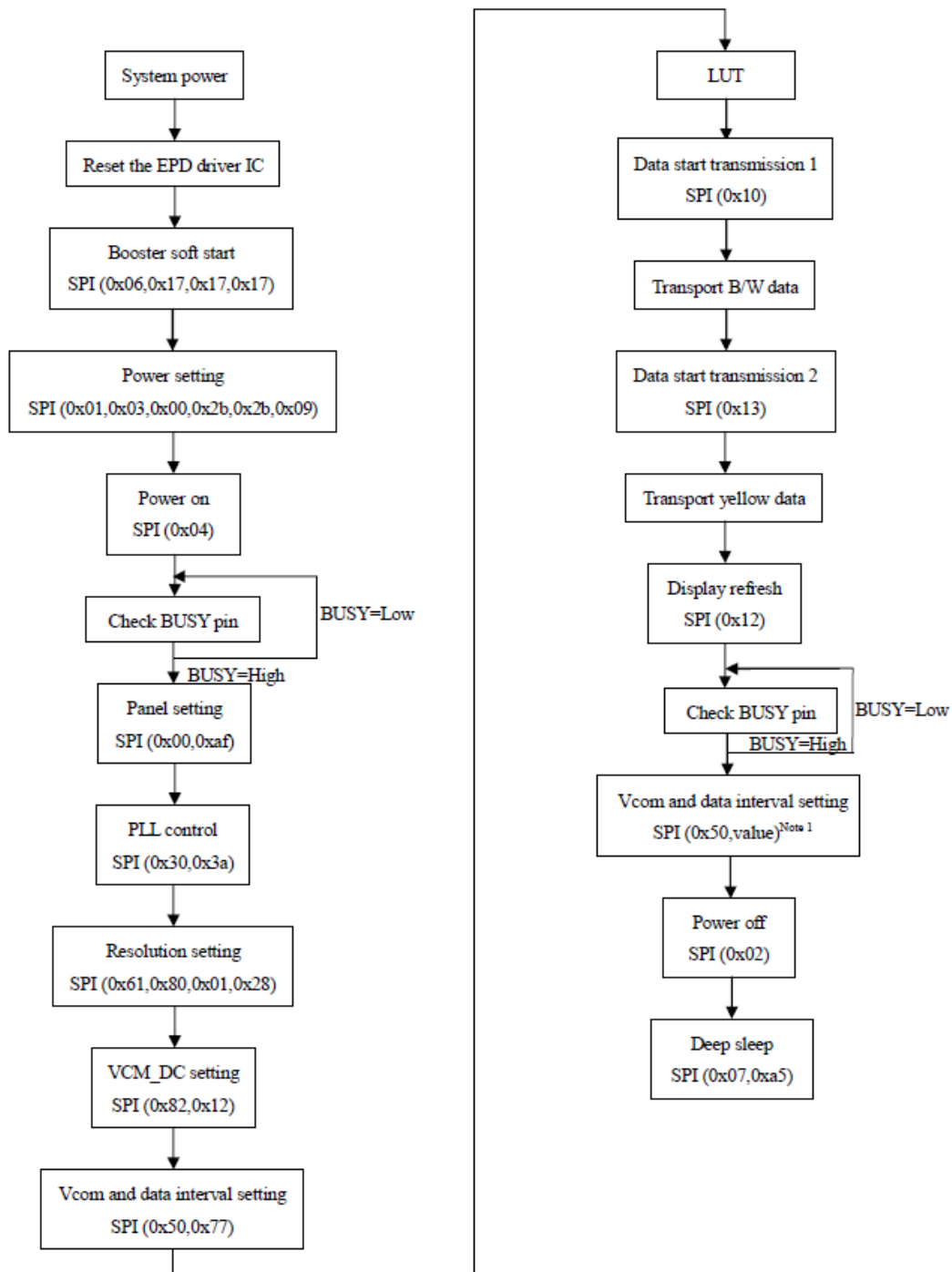

NOTE: Set border to floating.



8.2.2. BWY Mode & LUT from OTP

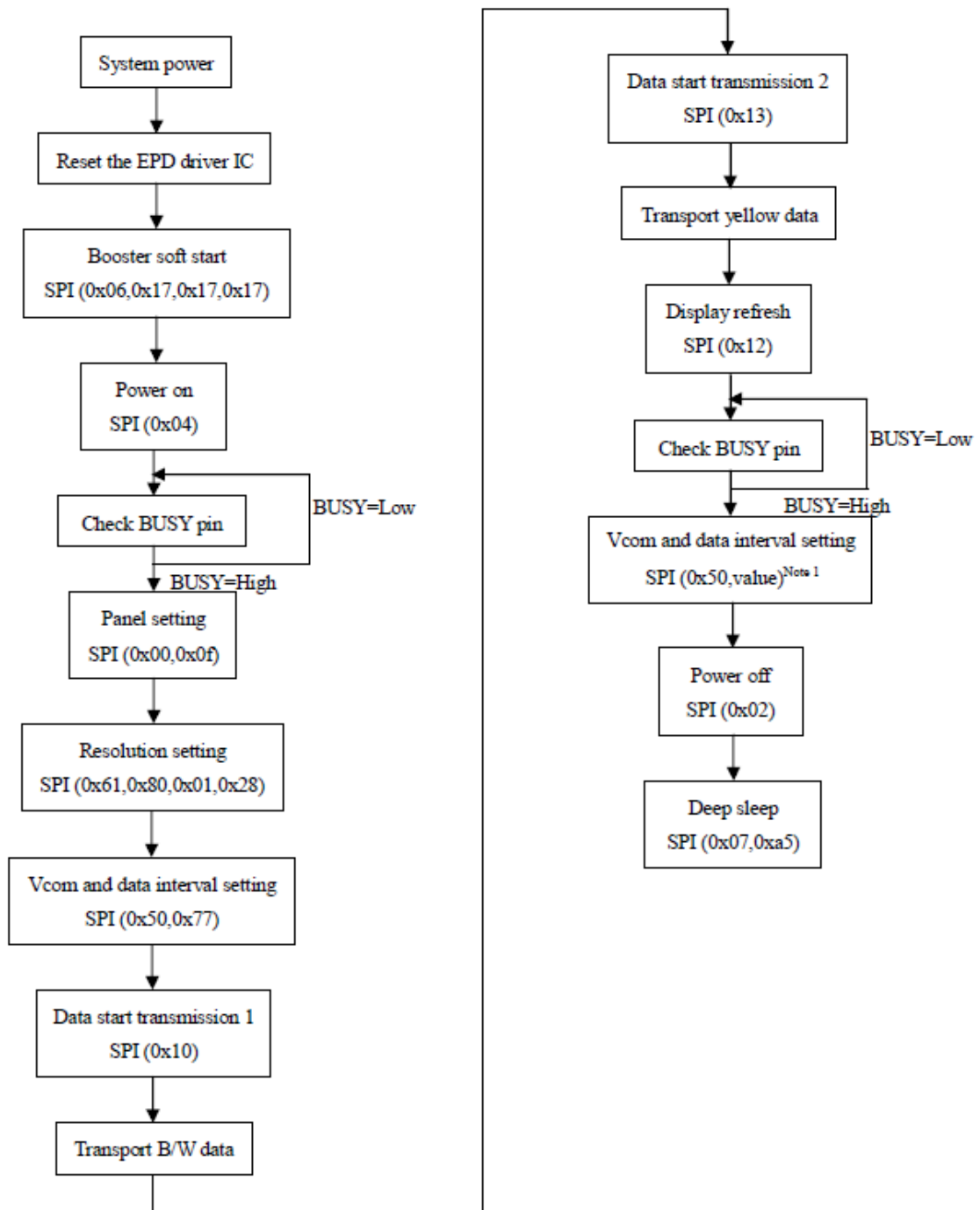

NOTE: Set border to floating.

9. Optical Characteristics

9.1. Specifications

Measurements are made with the illumination under an angle of 45 degrees, the detection is perpendicular unless otherwise specified.

T=25°C

Symbol	Parameter	Conditions	Min	Type	Max	Unit	Note
R	Reflectance	White	30	35	-	%	Note 9-1
Gn	2Gray Level	-	-	$DS + (WS - DS) \times n (m-1)$	-	L*	-
CR	Contrast Ratio	Indoor	8		-	-	-
Panel's Life	-	0°C~40°C	-	1,000,000 times or 5 years	-	-	Note 9-2
Panel	Image Update	Storage and Transportation	-	Update the White Screen	-	-	-
	Update Time	Operation	-	Suggest update once every 24-hours or at least every 10-days.	-	-	-

WS: White State, DS: Dark State

Gray State from Dark to White: DS, WS

m: 2

Note (9-1): Luminance meter: Eye – One Pro Spectrophotometer

Note (9-2): Panel life is not guaranteed when worked in temperatures below 0 degrees or above 40 degrees. Each update interval time should be at a minimum of 180 seconds.

9.2. Definition of Contrast Ratio

The contrast ratio (CR) is the ratio between the reflectance in a full white area (R1) and the reflectance in a dark area (Rd) ():

R1: White Reflectance Rd: Dark Reflectance

$CR = R1/Rd$

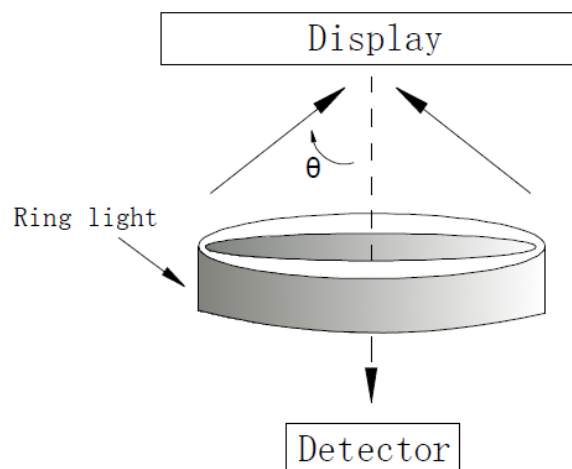

9.3. Reflection Ratio

The reflection ratio is expressed as:

$$R = \text{Reflectance Factor}_{\text{white board}} \times (L_{\text{CENTER}} / L_{\text{WHITE BOARD}})$$

L_{CENTER} is the luminance measured at center in a white area ($R=G=B=1$). $L_{\text{WHITE BOARD}}$ is the luminance of a standard white board. Both are measured with equivalent illumination source. The viewing angle shall be no more than 2 degrees.

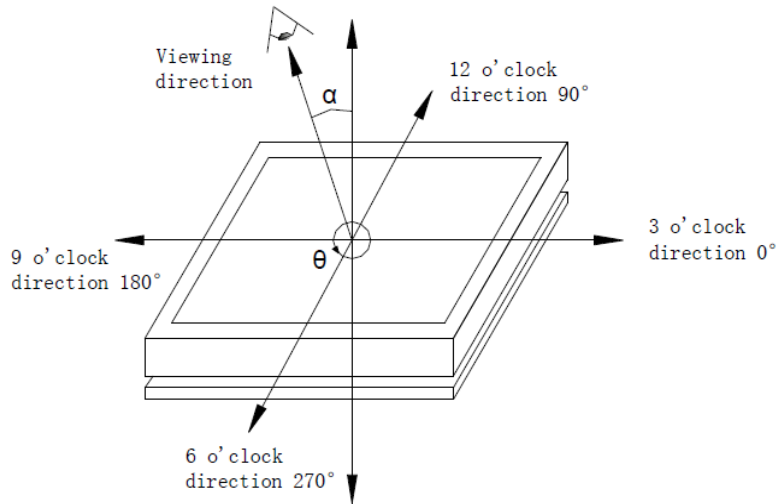

9.4. Bi-Stability

The Bi-Stability standard is as follows:

Bi-Stability	Result		
		AVG	MAX
24-Hour Luminance Drift	White state ΔL^*	-	3
	Black state ΔL^*	-	3

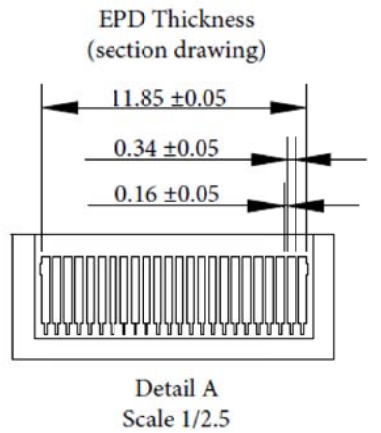
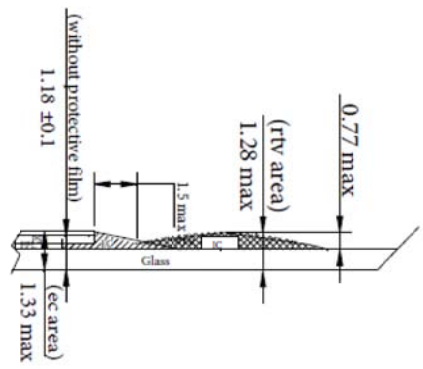
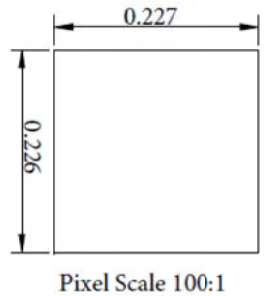
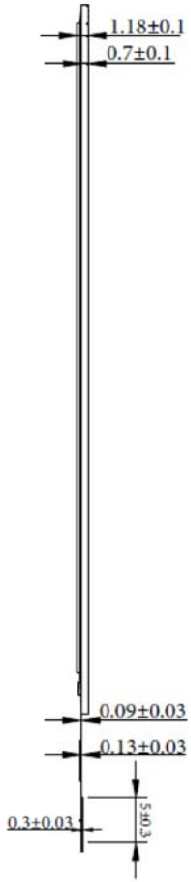
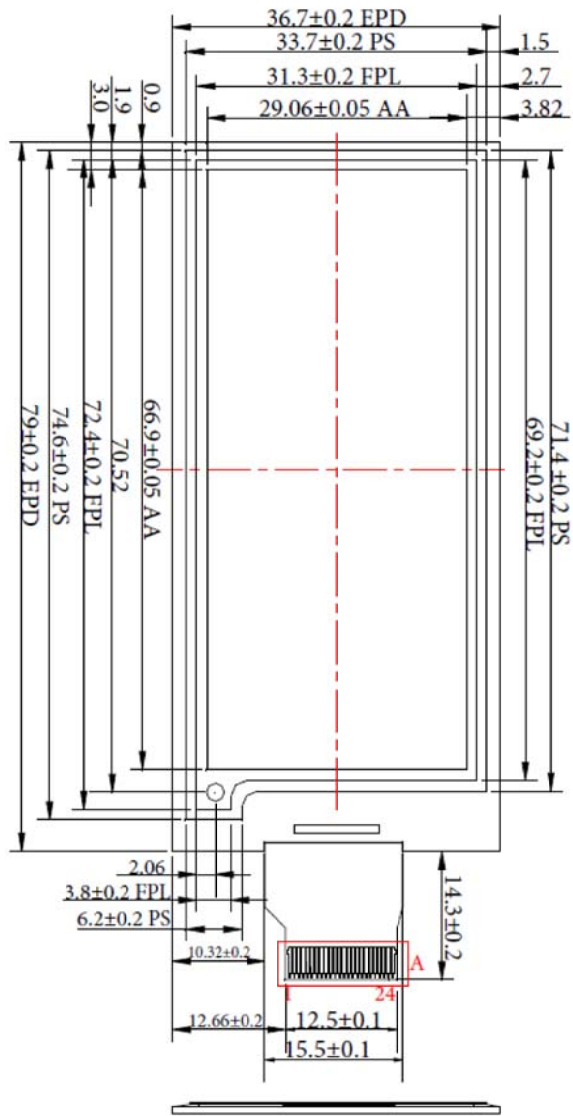

PART NUMBER(S) CFAP128296E0-0290	SCALE Not to Scale	COPYRIGHT © 2018 BY CRYSTALFONTZ AMERICA, INC. WWW.CRYSTALFONTZ.COM
DRAWING NUMBER CFAP128296E0-0290 master	UNITS Millimeters	DATE 2018-07-17

REV	ENGINEER	DATE	REMARKS
0v0	BAC	2018-04-04	Initial Creation
0v1	BAC	2018-05-17	Ind val, C12 val, JP_0P47 open, CN FPC
-	-	-	-
-	-	-	-
-	-	-	-

ESD border discharge



Scope Ground

