



GT968

Single Layer 5 Points Touch Screen Chip

Rev.05 — 08/12/2012

=====
Announcement of exemption
=====

The application information and other similar content in this publication are only provided for you and they may be substituted by any updated information. Your responsibility is to ensure application in conformity with technological specifications. GOODIX will not make any statement or guarantee, expressly or implied, in writing or orally, to such information, including but not limited to, any statement or warranty, legally or otherwise, to their use, quality, performance, marketability or suitability to special purpose. GOODIX shall not be liable for any outcome arising from such information or use of such information. Any product of GOODIX shall not be used as a vital component for life maintaining system without written consent from GOODIX. Under protection of GOODIX intellectual property rights, any license shall not be transferred secretly or otherwise.

Contents

1. Overview.....	3
2. Features	3
3. Chip Diagram.....	4
4. Pin Definition	5
5. Sensor Development	6
5.1 Parameter Requirement of Sensor Design.....	6
5.2 Touch Key Design	6
6. I ² C Communication.....	7
6.1 I ² C Communication	7
a) Data Transmission:	8
b) Write data to GT968.....	9
c) Read data from GT968.....	9
6.2 Register Information of GT968	10
a) Real Time Order.....	10
b) Configuration Information.....	10
c) Coordinates Information	15
7. Function Description	17
7.1 Working Mode	17
a) Normal Mode.....	17
b) Green Mode	17
c) Sleep Mode	17
7.2 Pulse Calling	17
7.3 Sleep Mode	18
7.4 Proximity Function.....	18
7.5 Parameter Frozen Function.....	18
7.6 Frequency Hopping Function	18
7.7 Automatic Calibration	18
a) Initialization Calibration	18
b) Automatic Temperature Drift.....	18
8. Reference Circuit Diagram	19
9. Electrical Characteristics	20
9.1 Absolute Operation Rating	20
9.2 Operating Characteristic.....	20
9.3 AC Characteristic	20
9.4 DC Characteristic	20
10. Product Package	21
11. Document History Page.....	22
12. Contact Information	23

1. Overview

GT968 uses the most advanced capacitive detective skills, built in high performance micro signal detect circuit, which can solve LCD interference and common mode interference successfully. On the software arithmetic side, it is specially designed based on electronic environment of single layer, support 5 points.

2. Features

- ◇ Built-in circuit and high performance MPU
 - Touch scanning frequency: 100Hz
 - 5 points touch, touch point output in coordinates type
 - Unified firmware version for different Touch-panel size
 - Single power supply, Built-in 1.8V LDO
 - Flash craft, support online burning
 - Proximity function
- ◇ Touch-panel sensor requirement
 - Supporting size: $\leq 4.5''$
 - Detecting channel: 17(Driving)*10(Sensing)
 - Support FPC touch keys
 - Support ITO Glass & ITO Film simultaneously
 - Cover lens thickness requirement: $0.7\text{mm} \leq \text{glass} \leq 2\text{mm}$, $0.5\text{mm} \leq \text{PET} \leq 0.9\text{mm}$
 - Built in frequency hopping function, support OGS full lamination
- ◇ Environmental applicable performance
 - Initialized automatic calibration
 - Automatic temperature drift compensation
 - Operating temperature: $-40^{\circ}\text{C} \sim +85^{\circ}\text{C}$, humidity: $\leq 95\% \text{RH}$
 - Storage temperature: $-60^{\circ}\text{C} \sim +125^{\circ}\text{C}$, humidity: $\leq 95\% \text{RH}$
- ◇ Communication interface
 - Standard I²C communication protocol
 - Support interface level of 1.8V~3.3V
 - Working in Slave mode
- ◇ Wake-up time
 - Green mode: <48ms
 - Sleep mode: <200ms
 - Initialization: <200ms
- ◇ Power supply:
 - Single power: 2.8V~3.3V

- ◇ Power ripple:
 - $V_{pp} \leq 50\text{mV}$
- ◇ Packaging: 40 pins, 5mm*5mm QFN_0.4P
- ◇ Development supporting tools
 - Touch-panel module's performance analysis tool
 - Parameter detector & configuration capture of touch panel
 - Q/C tools for mass production
 - Developing guide & reference code supporting

3. Chip Diagram

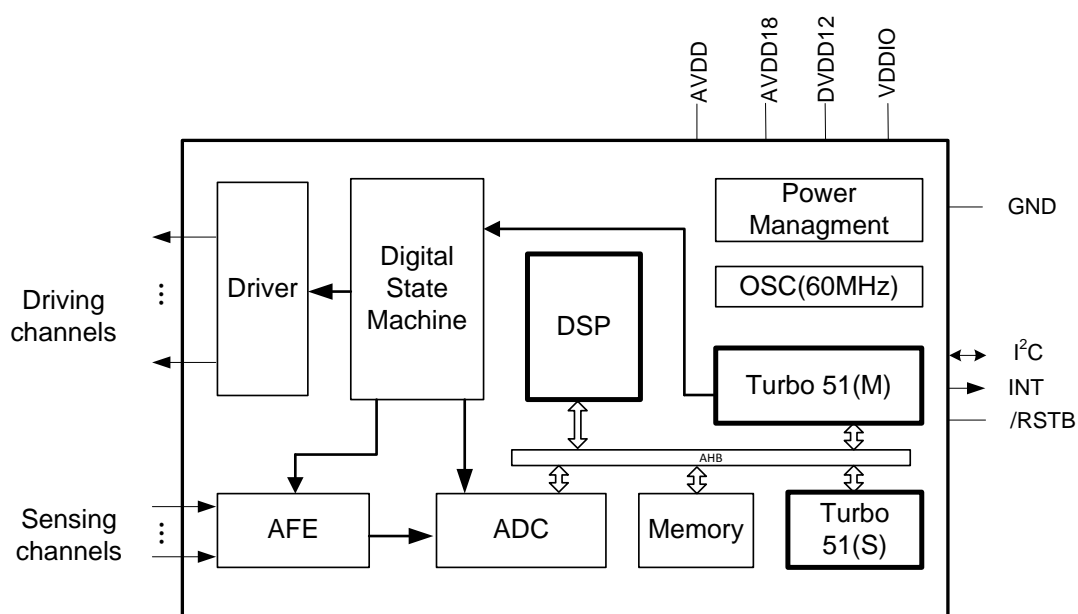

4. Pin Definition

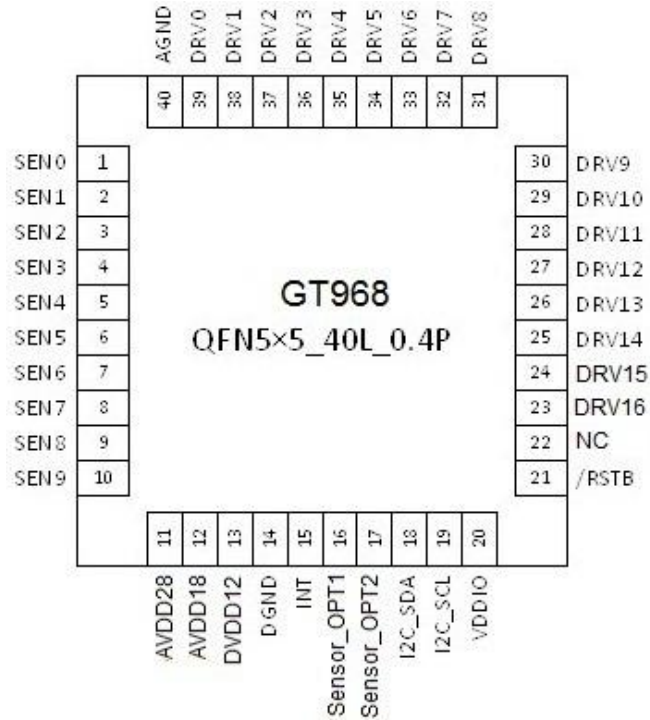

Pin No.	Name	Description	Note
1~10	SEN0~SEN9	Sensing channels	
11	AVDD28	Analog power	Connect 2.2uF Filter capacitor
12	AVDD18		Connect 2.2uF Filter capacitor
13	DVDD12		Connect 2.2uF Filter capacitor
14	DGND	Digit gnd	
15	INT	Interruption signal	By register
16	Sensor_OPT1	Module vender detecting	
17	Sensor_OPT2	Module vender detecting (Alternative)	External pull down res
18	I2C_SDA	I ² C_data	
19	I2C_SCL	I ² C_clock	
20	VDDIO	VDD of GPIO	Connect 2.2uF Filter capacitor 1、floating: 1.8V 2、to AVDD: AVDD
21	/RSTB	REST	External pull up, pull down reset
22	NC		
23~39	DRV16~DRV0	Driving channel	
40	AGND	Analog Ground	

5. Sensor Development

5.1 Parameter Requirement of Sensor Design

Sensor pattern design of single layer is the hardcore of a whole solution. All the pattern design are the patent of Goodix, all the new cases of module design are in charged by Goodix by now.

GT968	Routing mode	Proposal square resistance	Max square resistance	Proposal ITO gap	Max ITO gap	Pad space
Glass	All ITO	60Ω	100Ω	30um	50um	0.3mm
Film yellow ray	Unilateral alignment	100Ω	150Ω	50um	100um	0.4mm
Film yellow ray	Bilateral outlet	100Ω	150Ω	50um	200um	0.6mm
film screen printing	Bilateral outlet	150Ω	200Ω	200um	300um	0.6mm

5.2 Touch Key Design

GT968 can support 4 separate touch keys. There are two ways to design these touch keys:

Carried out by ITO sensor: Touch keys are carried out by one driving channel with different sensing channels. The driving channel is used only for touch keys, but the sensing channels should be reused by the visual area of the touch panel. the key position will be determined with configuration information.

Carried out by FPC: When using FPC to design touch keys, please comply with the principle above-mentioned.

6. I²C Communication

6.1 I²C Communication

GT968 provides standard I²C interface, which will be communicated between SCL & SDA and CPU. GT 968 is always works in slave mode, all the communication are set up by CPU, suggested communication speed is 400kbps or under. The supported I²C time sequence of hardware circuit as follows :

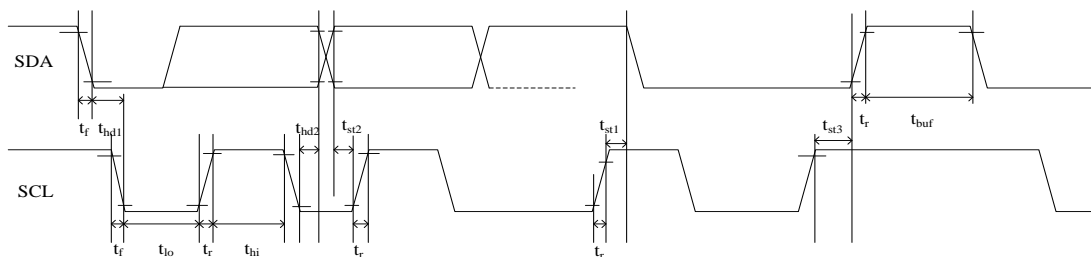

Test condition 1: 1.8V communication interface, 400KHz communication speed, pull-up register 2K

Parameter	Symbol	Min.	Max.	Unit
SCL low period	t_{lo}	0.9		us
SCL high period	t_{hi}	0.8		us
SCL setup time for START condition	t_{st1}	0.4		us
SCL setup time for STOP condition	t_{st3}	0.4		us
SCL hold time for START condition	t_{hd1}	0.3		us
SDA setup time	t_{st2}	0.4		us
SDA hold time	t_{hd2}	0.4		us

Test condition 2: 3.3V communication interface, 400KHz communication speed, pull-up register 2K

Parameter	Symbol	Min.	Max.	Unit
SCL low period	t_{lo}	0.9		us
SCL high period	t_{hi}	0.8		us
SCL setup time for START condition	t_{st1}	0.4		us
SCL setup time for STOP condition	t_{st3}	0.4		us
SCL hold time for START condition	t_{hd1}	0.3		us
SDA setup time	t_{st2}	0.4		us
SDA hold time	t_{hd2}	0.4		us

There are two groups of slave mode address of GT968, which are 0xBA/0xBB and 0x28/0x29. Master control controls Reset and INT pin to proceed setting when power on initialization, set up method and time sequence as follows:

Power on diagram:

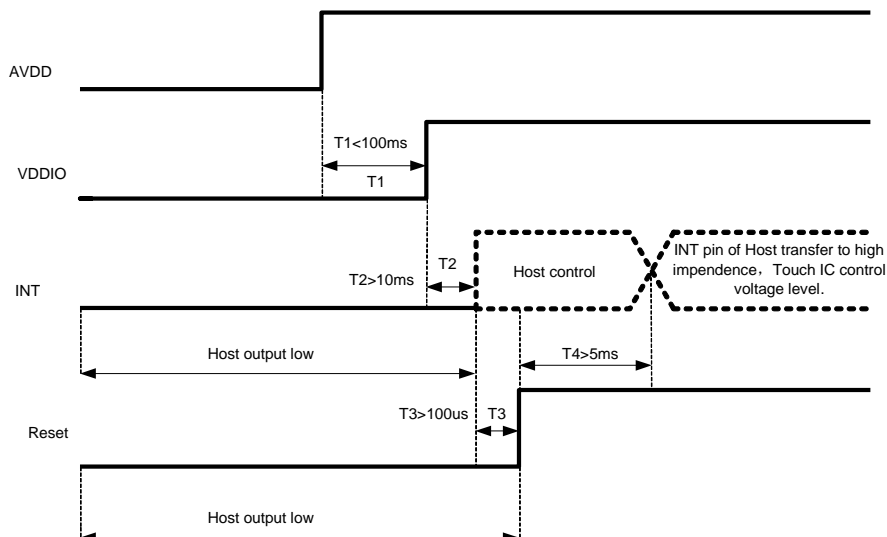

When address is 0x28/0x29:

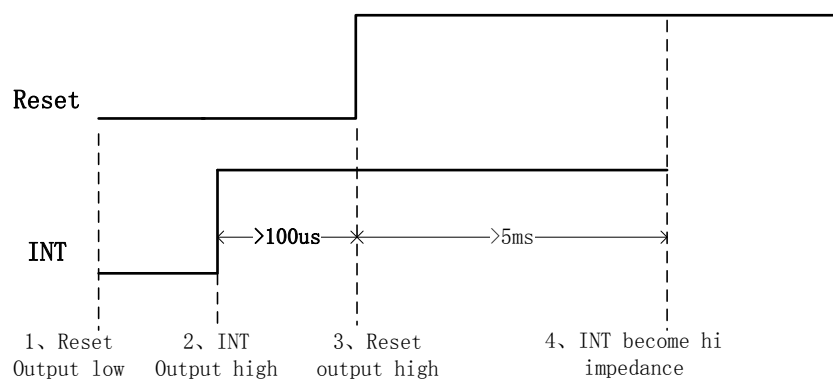

When address is 0xBA/0xBB:

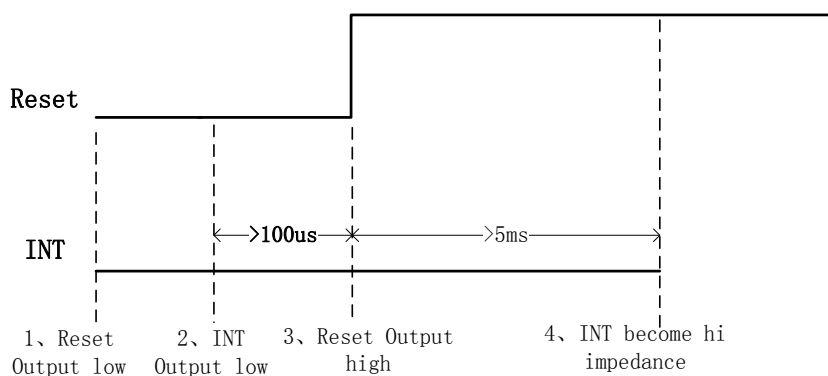

a) Data Transmission:

(eg: slave address is 0xBA/0xBB)

Communication is always initiated by master CPU, A high-to-low transition of SDA with SCL high is a start condition.

All addressing signal are serially transmitted to and from on bus in 8-bit words. GT968 sends a “0” to acknowledge when the addressing word is 0XBA or 0XBB. This happens during the ninth clock cycle.

The data words are serially transmitted to and from in 9-bit fomation: 8-bit data + 1-bit ACK or NACK sent by GT968. Data changes during SCL low periods and keeps valid during SCL high.

A low-to-high transition of SDA with SCL high is a stop condition.

b) Write data to GT968

(eg: slave address is 0xBA/0xBB)



Write operations time sequence

Please check the above figure, master start the communication first, and then sends device address 0XBA preparing for a write operation.

After receiving ACK from GT968, master sends out 16-bit register address, and then the data word in 8-bit, which is going to be wrote into GT968.

The address pointer of GT968 will automatically increase one after one byte writing, so master can sequentially write in one operation. When operation finished, master stop the communication.

c) Read data from GT968

(eg: slave address is 0xBA/0xBB)

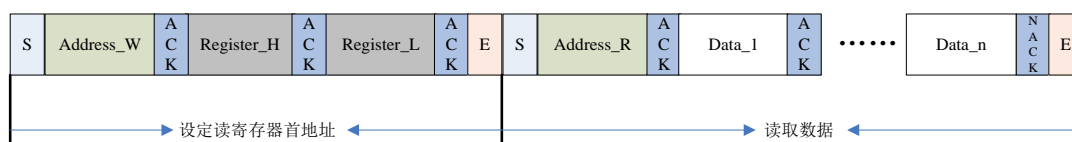

Read Operation

Please check the above figure, master start the communication first, and then sends device address 0XBA for a write operation.

After receiving ACK from GT968, master sends out 16-bit register address, to set the address pointer of GT968. After receiving ACK, master produce start signal once again, send device address 0xBB, then read data word from GT968 in 8-bit.

GT968 also supports sequential read operation, and the default setting is sequential read mode. Master shall send out ACK after every byte reading successfully but NACK after the last one. Then sends stop signal to finish the communication.

6.2 Register Information of GT968

a) Real Time Order

(Write Only)

Addr	Name	bit7	bit6	bit5	bit4	bit3	bit2	bit1	bit0
0x8040	Command	0: read coordinate 1: read diff data or raw data 2: software reset 3: baseline update 4: baseline calibration 5: screen off 3&4 are still internal test							
0x8041	Reserved	Reserved							
0x8042	Proximity_En	Switch of Proximity							

b) Configuration Information

(R/W)

Addr	name	bit7	bit6	bit5	bit4	bit3	bit2	bit1	bit0
0x8047	Config_Version	Version of the configuration							
0x8048	X Output Max_L	Resolution of X axis							
0x8049	X Output Max_H								
0x804A	Y Output Max_L	Resolution of Y axis							
0x804B	Y Output Max_H								
0x804C	Touch Number	Reserved				Touch number: 1~5			
0x804D	Module_Switch 1	Reserved		Stretch_rank		X2Y	Sito	INT trigger method	
0x804E	Module_switch 2	STP_E N	Reserved		Scap_ Sito_E N	Water_ Proof_ Disabl e	SCap_ Large_ En	SCap_ Merge _En	Touch _Key
0x804F	Shake_Count	Reserved				Finger shake count			
0x8050	Filter	First_Filter		Normal_Filter (filtering value of original coordinate window, coefficient is 1)					
0x8051	Large_Touch	Number of touch in large area							
0x8052	Noise_Reducti on	Reserved				Value of noise elimination (coefficient is 1)			
0x8053	S_Touch_Leve l	Threshold of touch grow out of nothing							
0x8054	S_Leave_Level	Threshold of touch decrease to nothing							
0x8055	Low_Power_C ontrol	Reserved				Time to low power consumption (0~15s)			
0x8056	Refresh_Rate	Reserved				Coordinate report rate (Cycle: 5+N ms)			
0x8057	x_threshold	Reserved							

0x8058	y_threshold				
0x8059	X_Speed_Limit	Reserved			
0x805A	Y_Speed_Limit				
0x805B	Space	Blank area of boarder-top		Blank area of Boarder-bottom	
0x805C		Blank area of boarder-left		Blank area of Boarder-right	
0x805D	NC	Reserved		Level of weak stretch (Strtch X/16 Pitch)	
0x805E	NC	Interval 1 coefficient			
0x805F	NC	Interval 2 coefficient			
0x8060	NC	Interval 3 coefficient			
0x8061	NC	All intervals base number			
0x8062	Drv_GroupA_Number	All_Driving	Reserved		Driver_Group_A_number
0x8063	Drv_GroupB_Number	Reserved		D_Freq	Driver_Group_B_number
0x8064	Sensor_Num	Sensor_Group_B_Number			Sensor_Group_A_Number
0x8065	FreqA_factor	Driver frequency double frequency coefficient of Driver group A GroupA_Frequency = Multiplier factor * baseband			
0x8066	FreqB_factor	Driver frequency double frequency coefficient of Driver group B GroupB_Frequency = Multiplier factor * baseband			
0x8067	Pannel_BitFreq_L	Baseband of Driver group A\B (1526HZ<baseband<14600Hz)			
0x8068	Pannel_BitFreq_H				
0x8069	Pannel_Sensor_TimeL	Time interval of the neighbouring two driving signal (Unit: us), Reserved.			
0x806A	Pannel_Sensor_TimeH				
0x806B	Pannel_Tx_Gain	reserved		Pannel_Drv_output_R, 4 gears	Pannel_DAC_Gain
0x806C	Pannel_Rx_Gain	Pannel_PGA_C	Pannel_PGA_R	Pannel_Rx_Vcm_i, 4 gears	Pannel_PGA_Gain (8 gears)
0x806D	Pannel_Dump_Shift	Reserved			Magnification coefficient of original value (The Nth power of 2)
0x806E	Drv_Frame_Control	Reserved	SubFrame_DrvNum		Repeat_Num
0x806F	NC	Reserved			
0x8070	NC	Reserved			
0x8071	NC	Reserved			
0x8072	Stylus_Tx_Gain	Undefined (invalid when stylus_priority=0)			
0x8073	Stylus_Rx_Gain	Undefined (invalid when stylus_priority=0)			

0x8074	Stylus_Dump_Shift	Undefined (invalid when stylus_priority=0)		
0x8075	Stylus_Touch_Level	Undefined (invalid when stylus_priority=0)		
0x8076	Stylus_Leave_Level	Undefined (invalid when stylus_priority=0)		
0x8077	Stylus_Control	Pen mode escape time out period (Unit: Sec)		
0x8078	NC	S-Style improve quantity	Reserved	
0x8079	NC	Reserved		
0x807A	Freq_Hopping_Start	Frequency hopping start frequency (Unit: 2KHz, 50 means 100KHz)		
0x807B	Freq_Hopping_End	Frequency hopping stop frequency (Unit: 2KHz, 150 means 300KHz)		
0x807C	Noise_Detect_Tims	Detect_Stay_Times	Detect_Confirm_Times	
0x807D	Hopping_Flag	Hop_E n	Reserved	Detect_Time_Out
0x807E	Hopping_Threshhold	Large_Noise_Threshold		Hopping_Hit_Threshold
0x807F	Noise_Threshold	Threshold of noise level		
0x8080	NC	Reserved		
0x8081	NC	Reserved		
0x8082	Hopping_seg1_BitFreqL	Frequency hopping segment band 1 central frequency (for driver A/B)		
0x8083	Hopping_seg1_BitFreqH			
0x8084	Hopping_seg1_Factor	Frequency hopping segment 1 central frequency coefficient		
0x8085	Hopping_seg2_BitFreqL	Frequency hopping segment band 2 central frequency (for driver A/B)		
0x8086	Hopping_seg2_BitFreqH			
0x8087	Hopping_seg2_Factor	Frequency hopping segment 2 central frequency coefficient		
0x8088	Hopping_seg3_BitFreqL	Frequency hopping segment band 3 central frequency (for driver A/B)		
0x8089	Hopping_seg3_BitFreqH			
0x808A	Hopping_seg3_Factor	Frequency hopping segment 3 central frequency coefficient		
0x808B	Hopping_seg4_BitFreqL	Frequency hopping segment band 4 central frequency (for driver A/B)		

0x808C	Hopping_seg4 _BitFreqH		
0x808D	Hopping_seg4 _Factor	Frequency hopping segment 4 central frequency coefficient	
0x808E	Hopping_seg5 _BitFreqL	Frequency hopping segment band 5 central frequency (for driver A/B)	
0x808F	Hopping_seg5 _BitFreqH		
0x8090	Hopping_seg5 _Factor	Frequency hopping segment 5 central frequency coefficient	
0x8091	NC	Reserved	
0x8092	NC	Reserved	
0x8093	Key 1	Key 1 Position: 0-255 valid (0 means no touch, it means independent touch key when 4 of the keys are 8 multiples)	
0x8094	Key 2	Key 2 position	
0x8095	Key 3	Key 3 position	
0x8096	Key 4	Key 4 position	
0x8097	Key_Area	Time limit for long press(1~16 s)	Touch valid interval setting: 0-15 valid
0x8098	Key_Touch_Le vel	Key threshold of touch key	
0x8099	Key_Leave_Le vel	Key threshold of leave key	
0x809A	Key_Sens	KeySens_1(sensitivity coefficient of key 1, same below)	KeySens_2
0x809B	Key_Sens	KeySens_3	KeySens_4
0x809C	Key_Restrain	The suppression time of keys when finger leave the screen	The independent button adjacent key suppression parameter
0x809D	NC	Reserved	
0x809E	NC	Reserved	
0x809F	NC	Reserved	
0x80A0	NC	Reserved	
0x80A1	NC	Reserved	
0x80A2	Proximity_Drv_ Select	Drv_Start_Ch (start channel of driving direction)	Drv_End_Ch (End channel)
0x80A3	Proximity_Sen s_Select	Sens_Start_Ch (start channel of sensing direction)	Sens_End_Ch (End channel)
0x80A4	Proximity_Touc h_Level	Proximity effective threshold value	
0x80A5	Proximity_Leav e_Level	Proximity ineffective threshold value	
0x80A6	Proximity_Sam ple_Add_Time	Sampled values accumulated times.	

	s	
0x80A7	Proximity_Sample_Dec_ValL	Sampled values minus this parameter before accumulate.
0x80A8	Proximity_Sample_Dec_ValH	
0x80A9	Proximity_Leave_Shake_Count	Stop proximity after this time
0x80AA	Self_Cap_Tx_gain	Self-capacitance transmit gain
0x80AB	Self_Cap_Rx_gain	Self-capacitance receive gain
0x80AC	Self_Cap_Dump_Shift	Self-capacitance amplification factor
0x80AD	SCap_Diff_Up_Level_Drv	The self-capacitance suppression value of suspended increase threshold(driving direction)
0x80AE	Scap_Merge_Touch_Level_Drv	Self-capacitance touch level(driving direction)
0x80AF	SCap_Pulse_TimeL	Self-capacitance pulse time(low byte)
0x80B0	SCap_Pulse_TimeH	Self-capacitance pulse time(high byte)
0x80B1	SCap_Diff_Up_Level_Sen	The self-capacitance suppression value of suspended increase threshold(sensing direction)
0x80B2	Scap_Merge_Touch_Level_Sen	Self-capacitance touch level(sensing direction)
0x80B3	NC	Reserved
0x80B4	NC	Reserved
0x80B5	NC	Reserved
0x80B6	NC	Reserved
0x80B7~ 0x80C0	Sensor_CH0~ Sensor_CH9	Corresponding channel no. of ITO Sensor
0x80C1~ 0x80D4	NC	Reserved
0x80D5~ 0x80E6	Driver_CH0~ Driver_CH16	Corresponding channel no. of ITO Driver0
0x80E7~ 0x80FE	NC	Reserved
0x80FF~ 0x810F	Drv0_Gain~ Drv16_Gain	Driver software gain
0x8110~	NC	Reserved

0x8128		
0x8129	Config_Chksu m	Check of configuration information
0x812A	Config_Fresh	Updated configuration (by master control)

c) Coordinates Information

Addr	bit7	bit6	bit5	bit4	bit3	bit2	bit1	bit0
0x8140	Product ID(Lowest Byte,ASCII 码-)							
0x8141	Product ID(Third Byte,ASCII 码 -)							
0x8142	Product ID(Second Byte,ASCII 码-)							
0x8143	Product ID(Highest Byte,ASCII 码-)							
0x8144	Firmware version(HEX low byte)							
0x8145	Firmware version(HEX high byte)							
0x8146	x coordinate resolution (low byte)							
0x8147	x coordinate resolution (high byte)							
0x8148	y coordinate resolution (low byte)							
0x8149	y coordinate resolution (high byte)							
0x814A	Vendor_id(module vender ID)							
0x814B	Reserved							
0x814C	Reserved							
0x814D	Reserved							
0x814E	buffer status	large detect	Proximity Valid	HaveKey	number of touch points			
0x814F	track id							
0x8150	point 1 x coordinate (low byte)							
0x8151	point 1 x coordinate (high byte)							
0x8152	point 1 y coordinate (low byte)							
0x8153	point 1 y coordinate (high byte)							
0x8154	Point 1 size (low byte)							
0x8155	point 1 size (high byte)							
0x8156	Reserved							
0x8157	track id							
0x8158	point 2 x coordinate (low byte)							
0x8159	point 2 x coordinate (high byte)							
0x815A	point 2 y coordinate (low byte)							
0x815B	point 2 y coordinate (high byte)							
0x815C	point 2 size (low byte)							
0x815D	point 2 size (high byte)							
0x815E	Reserved							
0x815F	track id							
0x8160	point 3 x coordinate (low byte)							
0x8161	point 3 x coordinate (high byte)							

0x8162	point 3 y coordinate (low byte)
0x8163	point 3 y coordinate (high byte)
0x8164	point 3 size (low byte)
0x8165	point 3 size (high byte)
0x8166	Reserved
0x8167	track id
0x8168	point 4 x coordinate (low byte)
0x8169	point 4 x coordinate (high byte)
0x816A	point 4 y coordinate (low byte)
0x816B	point 4 y coordinate (high byte)
0x816C	point 4 size (low byte)
0x816D	point 4 size (high byte)
0x816E	Reserved
0x816F	track id
0x8170	point 5 x coordinate (low byte)
0x8171	point 5 x coordinate (high byte)
0x8172	point 5 y coordinate (low byte)
0x8173	point 5 y coordinate (high byte)
0x8174	point 5 size (low byte)
0x8175	point 5 size (high byte)
0x8176	Reserved
0x8177	keyvaule

7. Function Description

7.1 Working Mode

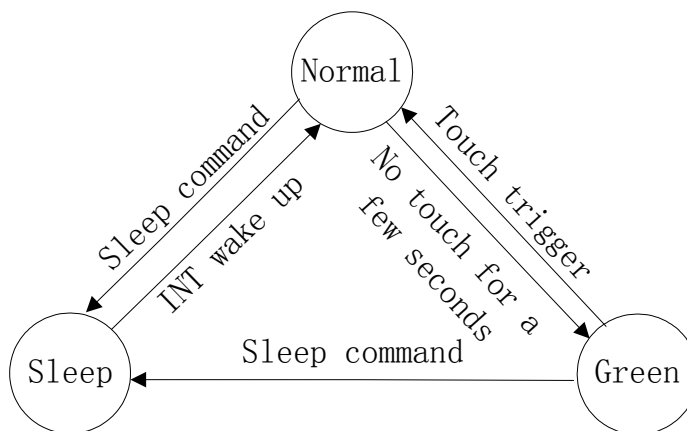

a) Normal Mode

When GT968 is in Normal mode, touch scanning cycle can be set with configuration information, and the cycle range is 7ms~10ms at the step 1ms. The time automatically entering from Normal mode into Green mode can also be set with configuration information, and its range is 0~15s at the step 1s.

b) Green Mode

In Green mode, the touch scanning cycle is fixed as 40ms. It will automatically enter into Normal mode if any touch is detected.

c) Sleep Mode

For a lower consumption, Master can set GT968 be in Sleep mode through I2C command. A rising edge on SHUTDN pin or INT can make GT968 return back to normal mode.

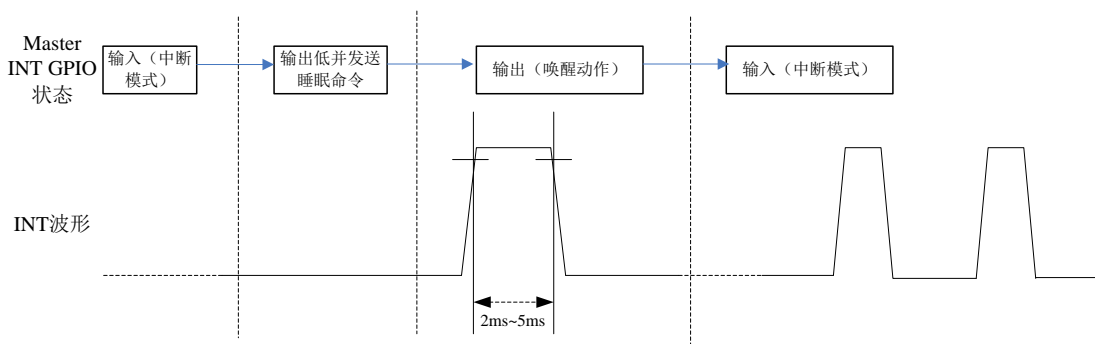

7.2 Pulse Calling

GT968 will inform master to read coordinate information only when touch event happen, in order to lighten the burden of master CPU. The master CPU will set trigger mode by

register 'INT'. "0" means rising edge trigger, in this mode GT968 will output an rising edge hopping in INT, to inform CPU; "1" means falling edge trigger.

7.3 Sleep Mode

When the display is turned off or in any circumstance that operation of touch panel is not necessary, master can set GT968 be in Sleep mode through I²C command. The master can wake up GT968 by outputting high to INT pin & keeping 2-5ms.

7.4 Proximity Function

GT968 has the function of proximity, this function is turned on when user is close to or touch the top area specified by configuration, GT968 will inform CPU to turn off LCD, and keep proximity status. When users leave the screen, GT968 will inform CPU to turn on LCD, and exit the status of proximity. When conversation is finished or users press the power key, CPU will inform GT968 to stop proximity detecting. It is suggested to cooperate with G-sensor, to optimize the user experience.

7.5 Parameter Frozen Function

GT968 support the function of Parameter frozen. When parameter is obtained, parameter can be settled in GT968 through Goodix test tool. If parameter has been frozen, GT968 will not receive the configuration with lower version from master.

7.6 Frequency Hopping Function

GT968 has very strong anti-interference hardware, when the driver spectrum of GT968 overlaid with spectrum of noise signal, it can be switch to another frequency by self-adaption frequency hopping mechanism, to avoid interference.

7.7 Automatic Calibration

a) Initialization Calibration

Different temperature, humidity and physical structure will affect the sensor's baseline. According to environmental situation GT968 will update the baseline automatically in initialized 200ms.

b) Automatic Temperature Drift

Slow change of temperature, humidity or dust and other environmental factors will also affect the sensor's baseline. GT968 calculates and analyzes historical data, and compare to the current data variation. Base on this, the baseline will be calibration automatically.

8. Reference Circuit Diagram

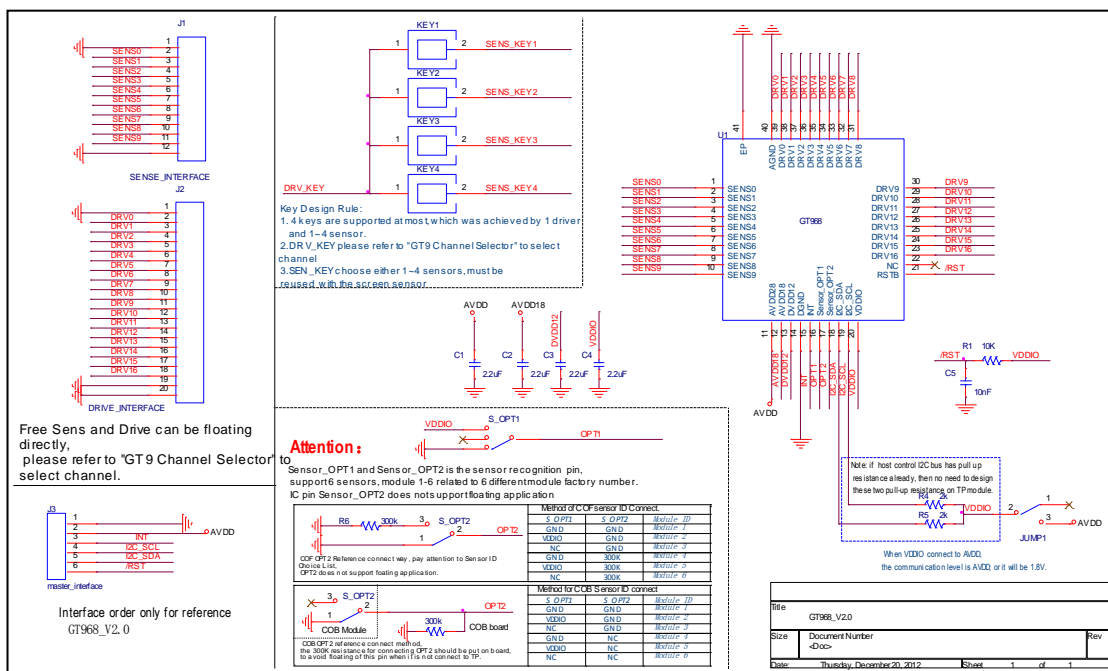

Reference Circuit Diagram of GT968

Notes:

1. This circuit only shows basic applications, and may be modified according to actual conditions.
2. The capacitor should be used material of X7R.

9. Electrical Characteristics

9.1 Absolute Operation Rating

(Temperature 25°C)

Parameter	Min.	Max.	Unit
Analog power AVDD28 (refer to AGND)	2.66	3.47	V
VDDIO (refer to DGND)	1.7	3.47	V
Input voltage on digital I/O	0	3.47	V
Input voltage on analog I/O	0	3.47	V
Operating temperature	-40	85	°C
Storage temperature	-60	125	°C
Welding temperature (10s)		300	°C
ESD protective voltage (HB Model)	-	2	KV

9.2 Operating Characteristic

Parameter	Min.	Typical	Max.	Unit
AVDD28	2.8	-	3.3	V
VDDIO	1.8	-	3.3	V
Operating temperature	-20	25	85	°C

9.3 AC Characteristic

(Temperature 25°C, AVDD=2.8V, VDDIO=1.8V)

Parameter	Min.	Typical	Max.	Unit
OSC oscillation frequency	59	60	61	MHz
I/O output rise time	—	—	0.5	ns
I/O output fall time	—	—	0.5	ns

9.4 DC Characteristic

(Temperature 25°C, AVDD=2.8V, VDDIO=1.8V)

Parameter	Min.	Typical -	Max.	Unit
Operating current (Normal mode)	-	6.2		mA
Operating current (Green mode)	-	3	-	mA
Operating current (Sleep mode)	70	-	120	uA
Input voltage in low level	-0.3	0	0.45	V
Input voltage in high level	1.35	1.8	2.1	V

10. Product Package

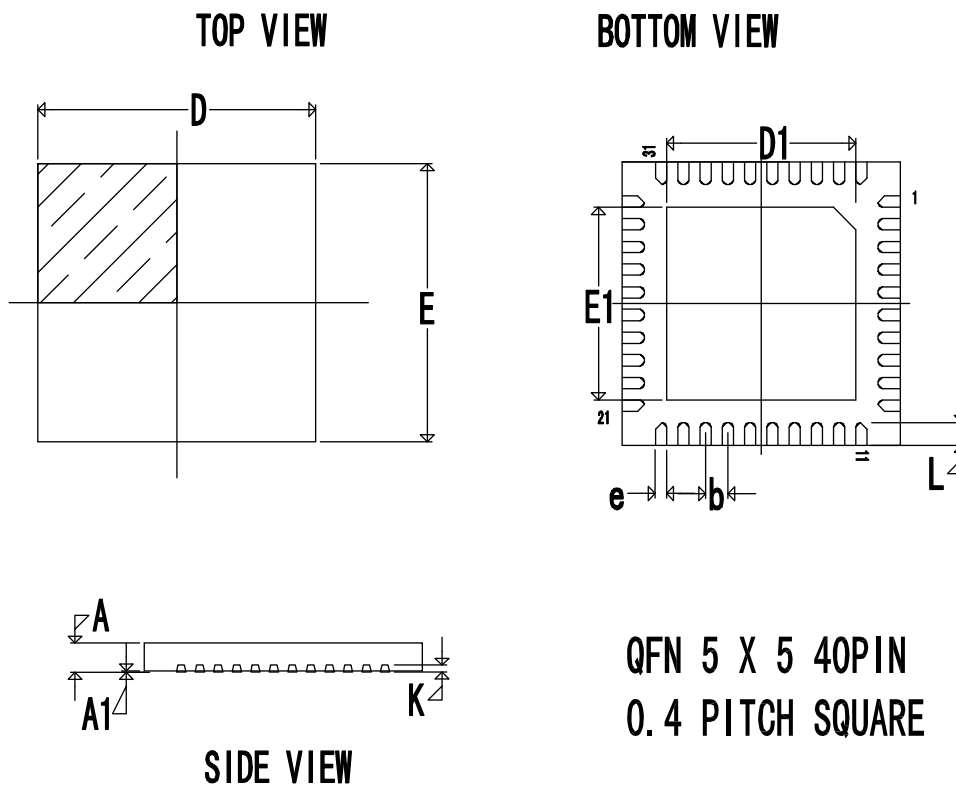

Symbol	Dimensions In Millimeters		
	Min.	Normal	Max.
A	0.70	0.75	0.80
A1	0.00	0.035	0.05
b	0.40BSC		
D	5.00BSC		
D1	3.30	3.50	3.80
E	5.00BSC		
E1	3.30	3.50	3.80
e	0.15	0.20	0.25
L	0.30	0.40	0.50
K	0.203BSC		

11. Document History Page

Version	Date	Description of change
Rev.00	2012-06-27	Pre-release
Rev.01	2011-7-12	New datasheet, confirm electrical characteristics
Rev.02	2012-07-12	Revise reference circuit diagram
Rev.03	2012-07-13	Revise package size
Rev.04	2012-11-09	1. Added power on diagram 2. Modified reference circuit diagram
Rev.05	2012-12-08	1. Modified storage temperature, operating current in different mode, etc. 2. Modified Package Information

12. Contact Information



Shenzhen Huiding Technology Co., Ltd.

Address: Floor 13, Phase B, TengFei Industrial Building, FuTian Free Trade Zone, ShenZhen, 518000

TEL: +86-755-33338828

FAX: +86-755-33338787

www.goodix.com