



DATA SHEET

(DOC No. HX8655-A-DS)

HX8655-A

272/240CH TFT Gate Driver
Version 03 April, 2006

HiMAX 奇景光電股份有限公司

文件發行及參考文件

Data:

To:

DOCUMENT CONTROL CENTER

>> HX8655-A

272/240CH TFT Gate Driver



Himax Technologies, Inc.
<http://www.himax.com.tw>

Version 03

April, 2006

1. General Description

The HX8655-A is a TFT-LCD driver with 272/240 output channels. Each channel can output high/low voltage to turn on/off TFT switch on TFT/LCD panel. It also has power supply circuit for Gate driving as well as common electrode driving.

2. Features

- CMOS level input (2.25 to 3.6V)
- 272/240 channels output selectable
- DC/DC converter circuit for gate driving include (VDC x [4], VDC x [-2])
DC/DC converter circuit for COMMON L level regulator include (VDC x [-1])
High-output voltage (VGH to VGL: 33V MAX)
- Input terminal symmetrical placement
- Including common electrode driving circuit
- Including voltage regulator for source driver gamma circuit
- COG package

Himax Confidential
Do Not Copy



Himax Confidential

This information contained herein is the exclusive property of Himax and shall not be distributed, reproduced, or disclosed in whole or in part without prior written permission of Himax. **Subject to change without notice.**

-P.1-
April 2006

3. Block Diagram

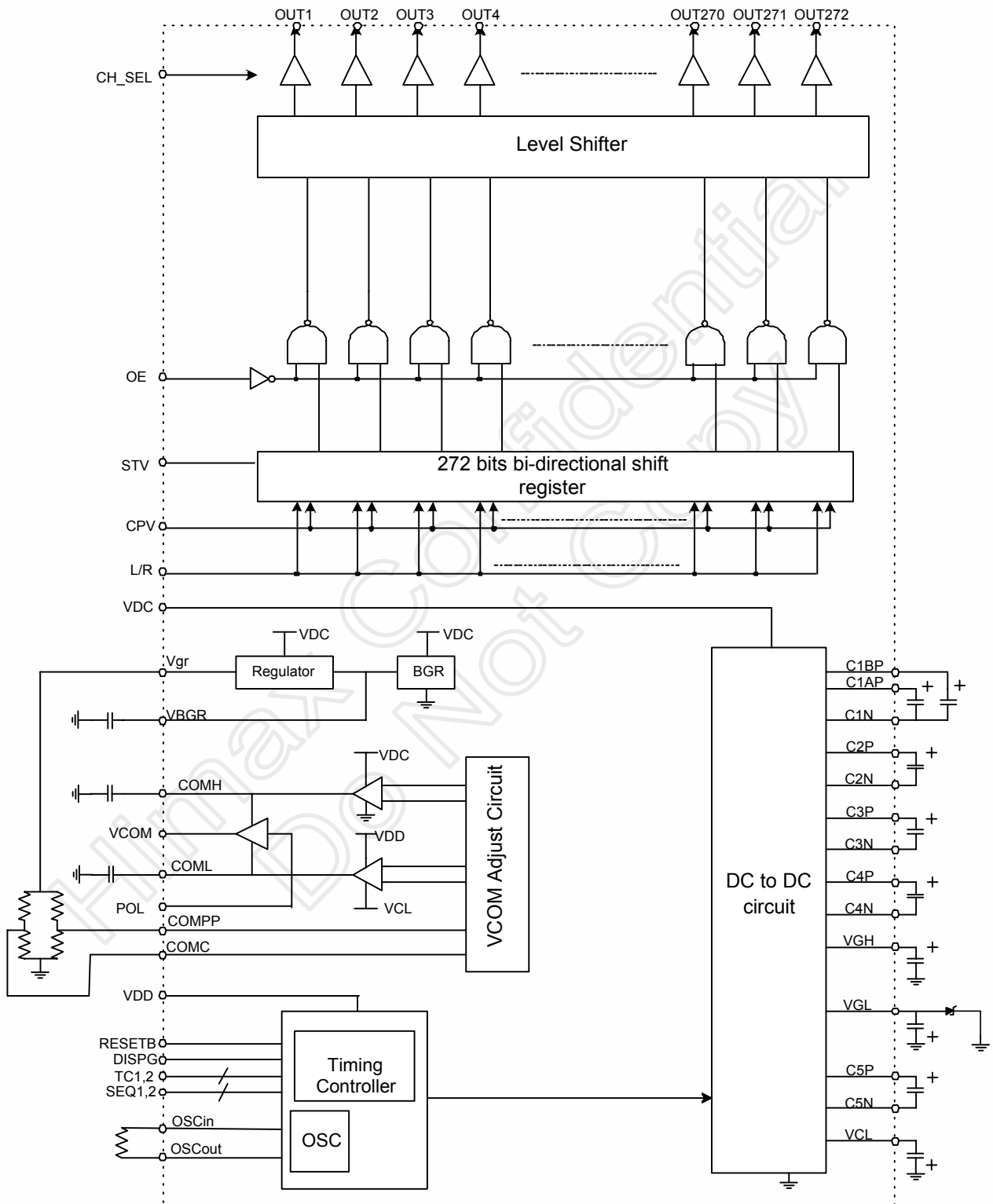

4. Pin Description

Pin name	I/O	Function	Description
CPV	In	Shift clock input	This is the clock input for chip internal shift register. Data is shifted at each rising edge of this clock.
L/R	In	Shift direction control pin	This pin controls the output shifting direction as listed below. L/R=H, STV→OUT1→OUT2→...→OUT272 L/R=L, STV→OUT272→OUT271→...→OUT1
STV	In	Start pulse input pin	This pin is the device start pulse input pin.
OE	In	Output enable control	This pin is used for controlling the channel output. When OE input is H, driver output is fixed to L regardless CPV. However, the internal shift register is not cleared even if OE input is inactive.
OUT1 ~ OUT272	Out	Driver output pins for driving gate electrode of LCD	The output voltage is either VGH or VGL for driving the gate electrode of TFT LCD panel depending on the data stored in shift register and the state of OE.
VGH	In	Power supply	Power supply for LCM drive output High
VDD	In	Power supply	Digital power
VSS	In	Power supply	Digital ground
VGL	In	Power supply	LCD driver negative power supply
VCL	In	Power supply	LCD driver negative power supply2
VBGR	Out	Power supply	Output pin of internal reference voltage.
Vgr	Out	Power supply	Output pin of internal regulator circuit.
COMH	Out	Power supply	Output pin of regulator for COMMON output H level.
COML	Out	Power supply	Output pin of regulator for COMMON output L level.
COMPP	In	Power supply	Adjust the amplitude voltage level for COMMON output
COMC	In	Power supply	Adjust the amplitude voltage level for COMMON output
C1AP, C1BP, C1N, C2P, C2N C3P, C3N, C4P, C4N, C5P, C5N	-	Capacitor for boosting connection pins	Connect 1μF capacitor between CnP and CnN pins.
VCOM	Out	Power supply	This is output pin for COMMON signal of a TFT panel.
POL	In	Power supply	This is the input pin for COMMON signal of a TFT panel.
DISPG	In	Power circuit start-up	Power circuit start-up setting pin. When DISPG is set to H, DC/DC converter circuit starts the operation set by SEQ2 and SEQ1 sequentially.
RESETB	In	Reset pin	Low Reset. Initialize the IC when low. It must be reset after power-on.
TC1 TC2	In	Operation clock control	DC/DC converter operation clock frequency control. The setting of these pins is for controlling the operation clock frequency of DC/DC converter circuit.
SEQ2 SEQ1	In	Power circuit start-up control	Power circuit start-up timing control. When DISPG set to H, DC/DC converter is inactive.



Pin name	I/O	Function	Description
OSCIN OSCOU	I/O	Oscillation pins	Connect 75K ohm resistor between OSCIN and OSCOUT pins.
TEST1 TEST2	-	Test mode pins	TEST1=H and TEST2=H: Normal mode TEST1 or TEST2 =L: TEST mode This pin is pulled high internally.
Dummy	-	Dummy	No dummy pins are connected with other pins inside IC.
VDC	In	Power supply	Power supply pin for reference voltage of DC/DC converter circuit. VDC=5.0V.
CH_SEL	In	Output channel select pin	Select 272/240 channels output. (Normally pull high) CH_SEL=H: 272 channel output CH_SEL=L: 240 channel output, using OUT17~OUT256. Others are fixed to VGL.



5. Function Description

5.1 Device operation

In the condition of L/R=H, the STV start pulse input is sensed at the rising edge of CPV and stored in the first stage of shift register, which causes the first scan signal is outputted from the OUT1 output pin. While stored data is transferred to the next stage shift register at the rising edge of next CPV, new data of STV is sensed and stored simultaneously.

The output pin (OUT1 to OUT272) supplies VGH voltage or VGL voltage to the LCD panel depending on the data stored in the shift register. For normal operation, a VGH voltage is outputted one by one from OUT1 to OUT272 in sync with CPV pulse.

During any H state of OE, the corresponding output channels are forced to VSS regardless of CPV. The channel output returns to normal status as soon as OE goes back to L.

Example of input/output timing L/R=H

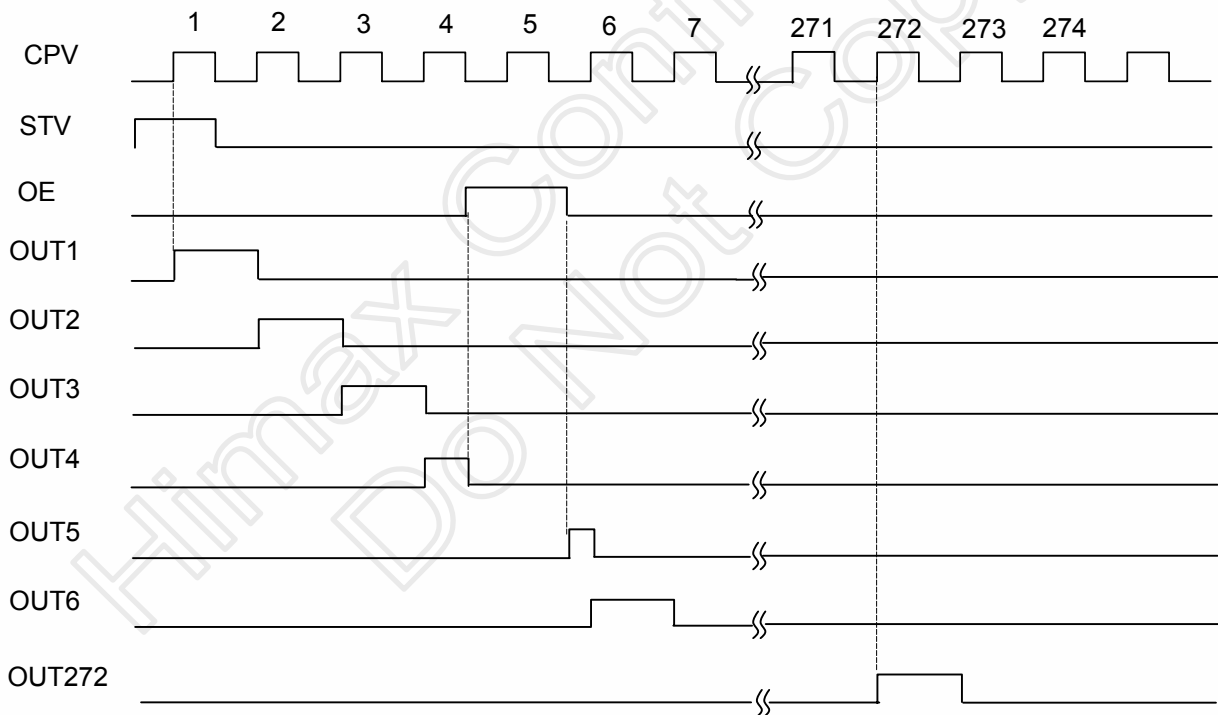

5.2 Relationship among L/R

L/R	Data transfer direction
H	OUT1→OUT2→OUT3→ . . . →OUT272
L	OUT272→OUT271→OUT270→ . . . →OUT1

5.3 Device power supply

The HX8655-A must be used by the following conditions.

VGH - VGL = 33V (max.)

VGH - VSS = 10 ~ 30V

Example

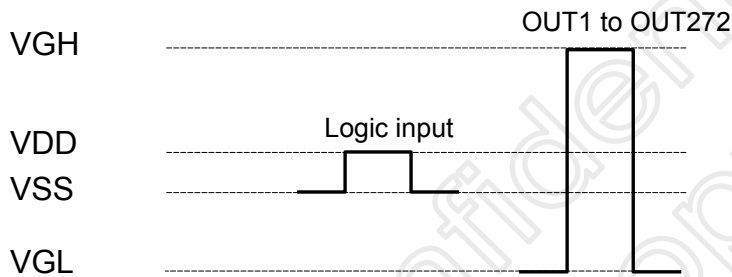

The input signal level of CPV, L/R, OE, and STV have to swing between VDD and VSS.

5.4 Power ON/OFF sequence

To prevent the device damage from latch up, the power ON/OFF sequence is shown below. The sequence of VGL, VGH and VCL is controlled by HX8655-A itself.

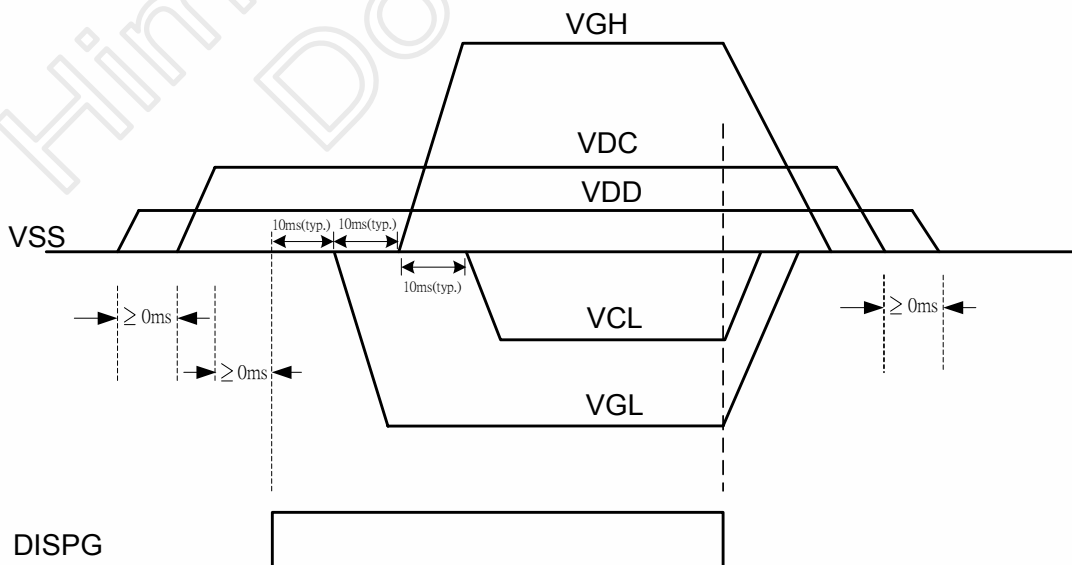

5.5 Timing controller circuit

Timing controller circuit controls the operation frequency of DC-to-DC circuit.

TC2	TC1	Operation frequency
0	0	12.5KHz
0	1	100KHz
1	0	50KHz
1	1	25KHz (default)

5.6 Power circuit set-up sequencer

Power circuit set-up sequencer controls the start-up timing of DC-to-DC circuit.

SEQ2	SEQ1	Start-up time after DISPG=H
0	0	After 1/12Hz (83ms)
0	1	After 1/24Hz (42ms)
1	0	After 1/48Hz (21ms)
1	1	After 1/97Hz (10ms) (default)

5.7 Oscillator

HX8655-A has an oscillator circuit inside the IC. A 75K ohm resistor must be connected between OSCIN and OSCOUT. The oscillator frequency is used as the base clock of power circuit.

5.8 Common output circuit

HX8655-A has a common output circuit for TFT panel. POL is input to decide the polarity of common voltage, and common output circuit will provide a toggle signal with COMH and COML voltages to TFT panel.

COMH and COML voltage level are adjusted by input voltage COMPP and COMC. Relationship between COMH, COML, COMPP and COMC are shown as below:

$$\begin{aligned} \text{COMH} &= \text{COMC} + \text{COMPP} \\ \text{COML} &= \text{COMC} - \text{COMPP} \\ \text{COMH} &= 4.3\text{V} \sim 2\text{V} \\ \text{COML} &= -3.5\text{V} \sim 0\text{V} \\ \text{COMPP, COMC} &= 0.1 \sim (\text{VDC}-1\text{V}) \end{aligned}$$

5.9 Regulator for gamma circuit of source driver

HX8655-A has regulator circuit for gamma circuit of source driver resistor strings. The output of this circuit must be connected to Vgr pin of source driver. Typical Vgr voltage level is 4.5V.



5.10 Reset

HX8655-A is reset internally by RESETB input. The RESETB must be held for at least 1ms after VDD is stable.

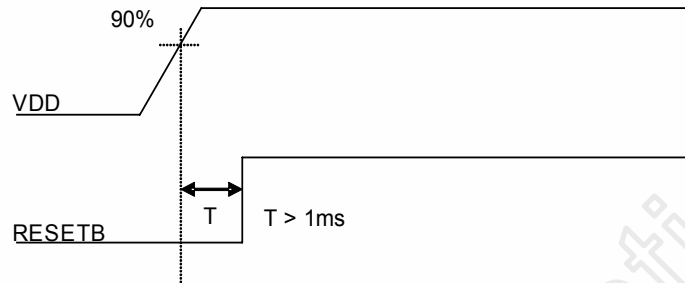

5.11 DC/ DC external component

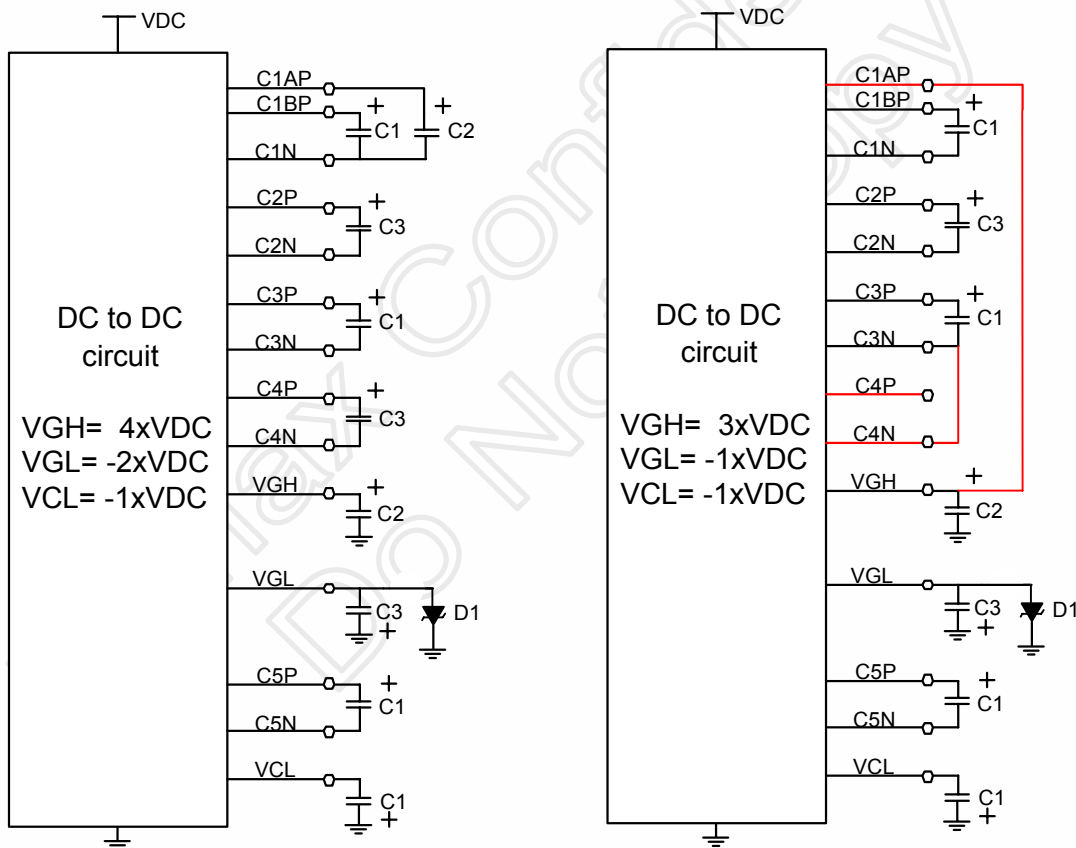

	Value	Accuracy	Voltage proof
C1	1.0μF	+/- 10%	10V
C2	1.0μF	+/- 10%	25V
C3	1.0μF	+/- 10%	16V

		Voltage proof	Characteristics
D1	Schottky Barrier Diode	>25V	IF>200mA



5.12 Regulator for Gamma circuit of source driver

HX8655-A has a regulator circuit for source driver's gamma resistor strings. Connect this output to source driver Vgr pin. Vgr voltage level is 4.5V. (Typ.)

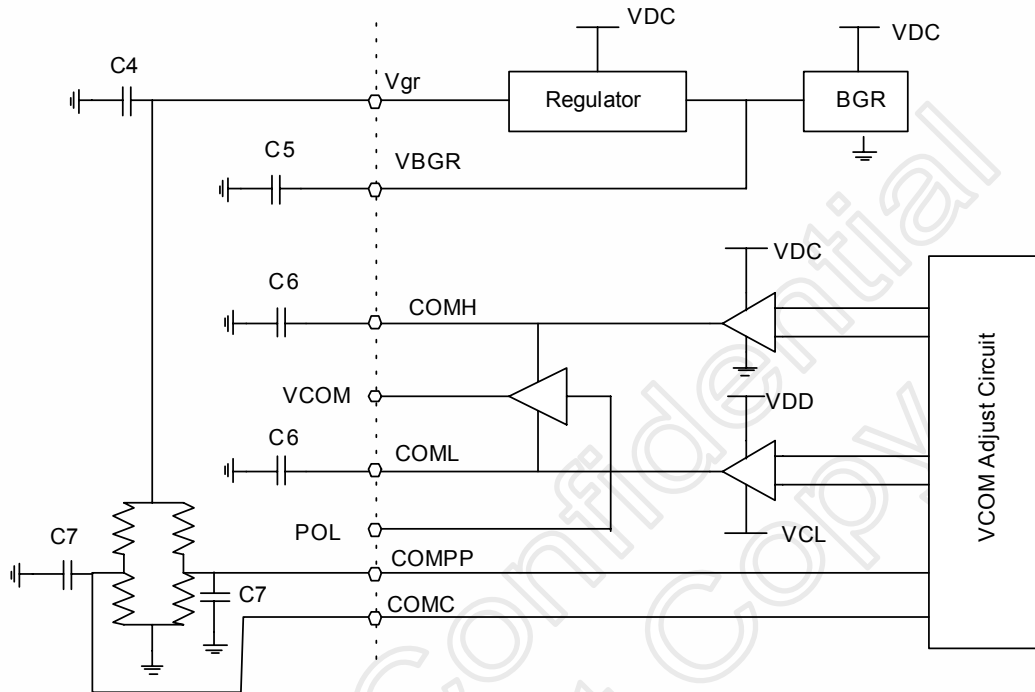

	Value	Accuracy	Voltage proof
C4	1.0 μ F	+/- 10%	10V
C5	0.1 μ F	+/- 10%	6.3V
C6	2.2 μ F ~10 μ F	+/- 10%	10V
C7	0.01 μ F ~0.1 μ F	+/- 10%	10V



5.13 Value of wiring resistance to each pin

The recommended wiring resistance values are shown below. The wiring resistance values affect the current capacity of the power supply, so be sure to design using values that do not exceed those recommended.

Pin Name	Wiring resistance value(Ω)
VDD	< 30
VDC	< 5
VSS	< 5
VGH	< 20
VGL	< 10
VCL	< 10
VBGR	< 30
Vgr	< 20
COMH	< 10
COML	< 10
COMOUT	< 10
C1AP	< 20
C1BP	< 20
C1N	< 20
C2P	< 20
C2N	< 20
C3P	< 20
C3N	< 20
C4P	< 20
C4N	< 20
C5P	< 10
C5N	< 10
OSCIN	< 800 ⁽¹⁾
OSCOU	< 800 ⁽¹⁾
POL	< 800
CPV	< 800
STV	< 800
OE	< 800
SEQ1	< 1000
SEQ2	< 1000
TC1	< 1000
TC2	< 1000
L/R	< 1000
COMPP	< 1000
COMC	< 1000
DISPG	< 1000
RESETB	< 1000

Note: (1) The total resistance of (OSCIN wiring resistance + OSCOUT wiring resistance + external resistance between OSCIN and OSCOUT) will decide the OSC frequency.



6. DC Characteristics

6.1 Absolute Maximum Rating (VSS=0V)

Parameter	Symbol	Rating			Unit
Power supply voltage 1	VDD	-0.3	to	+8.0	V
Power supply voltage 2	VDC	-0.3	to	+8.0	V
Power supply voltage 3	VGH-VGL	-0.3	to	+45.0	V
Power supply voltage 4	VDD-VCL	-0.3	to	+10.0	V
Input voltage	V _{IN}	-0.5	to	VDD+0.5	V
Operation temperature	T _{OPR}	-30	to	+85	°C
Storage temperature	T _{STG}	-55	to	+125	°C

Note: (1) All of the voltages listed above are with respect to VSS=0V.

(2) Device is subject to be damaged permanently if stresses beyond those absolute maximum ratings listed above.

6.2 Recommended Operating Conditions (VSS=0V)

Parameter	Symbol	Rating			Unit
		Min.	Typ.	Max.	
Power supply voltage 1	VDD	2.25	2.5	3.6	V
Power supply voltage 2	VDC	4.75	5.0	5.5	V
Power supply voltage 3	VGH-VGL	28.5	30.0	33.0	V
Power supply voltage 4	VDD-VCL	7.0	7.5	8.25	V
Input Voltage	V _{IN}	0	-	VDD	V
Operation frequency	F _{CPV}	-	-	200	KHz
Operation temperature	T _a	-30	-	+80	°C



6.3 DC Electrical Characteristics (VSS=0V)

(VDD=2.25V to 3.6V, VDC=5V, VSS=0V, VGH=4*VDC, VGL=-2*VDC, VCL=-1*VDC)

Parameter	Symbol	Condition	Rating			Unit
			Min.	Typ.	Max.	
Input H voltage	V _{IH}	CPV, STV, L/R, OE	0.8VDD	-	VDD	V
Input L voltage	V _{IL}		VSS	-	0.2VDD	
Output H voltage	V _{OH}	I _{OH} =200μA	VDD-0.3	-	VDD	
Output L voltage	V _{OL}	I _{OL} =200μA	VSS	-	VSS+0.3	
Output H resistance	R _{OH}	V _{OUT} = VGH-1.0V	-	-	1000	Ω
Output L resistance	R _{OL}	V _{OUT} = VGL+1.0V	-	-	1000	Ω
Pull high resistance	R _{PU}	TC1, TC2, SEQ1, SEQ2, TEST1, TEST2, CH_SEL	150	-	-	kΩ
Vgr output current	I _{vgr}	-	-	-	2	mA
Regulator output voltage	V _{gr}	No load	4.4	4.5	4.6	V
VGH voltage	VGH	External C=1μF	-	4VDC	-	V
VGL voltage	VGL	External C=1μF	-	-2VDC	-	V
VCL voltage	VCL	External C=4.7μF	-	-VDC	-	V
VCOMH output voltage	VCOMH	No load. COMC=0.65V, COMPP=3.65V	4.2	4.3	4.4	V
VCOML output voltage	VCOML	No load. COMC=0.65V, COMPP=3.65V	-3.1	-3.0	-2.9	V
Input leakage current	I _{IN}	V _I =0V or 2.75V	-1.0	-	+1.0	μA
VDD Power consumption	I _{VDD}	No load, VDD=2.5V, VDC=5.0V F _{CPV} =20KHz, OE =V _{IL}	-	150	200	μA
VDC Power consumption	I _{VDC}		-	1800	2500	

Note: (1) Power consumption with the following condition:

Output no load, VGH =20V, VGL = -10V, VDD =2.5V, **VDC =5.0V**, V_{IH}=VDD, V_{IL}=VSS, F_{CPV}=20KHz, OE =V_{IL},



7. AC Characteristics

(VDD=2.25V to 3.6V, VDC=5V, VSS=0V, VGH=4*VDC, VGL=-2*VDC, VCL=-1*VDC)

Parameter	Symbol	Condition	Spec			Unit
			Min.	Typ.	Max.	
Oscillation frequency	f_{OSC}	-	130	200	250	kHz
VCOM output rise time ⁽¹⁾	t_{COMR}	CL=100nF	-	-	32	
VCOM output fall time ⁽²⁾	t_{COMF}	CL=100nF	-	-	32	
CPV period	t_{CPV}	-	5	-	-	
CPV pulse width ⁽³⁾	t_{CPVH}, t_{CPVL}	50% duty cycle	2.5	-	-	
OE pulse width	t_{WOE}	-	1	-	-	
Data setup time	t_{SU}	-	0.2	-	-	
Data hold time	t_{HD}	-	0.3	-	-	
CPV to output delay time	t_{PD1}	CL=220pF	-	-	0.9	
OE to output delay time	t_{PD2}	CL=220pF	-	-	0.8	

Note: (1) 10 to 90% of (COMH-COML)

(2) 90 to 10% of (COMH-COML)

(3) For non 50% duty cycle application, min. CPV pulse width $t_{CPVH} = 0.7\mu s$

Himax Confidential
Do Not Copy



8. Waveform

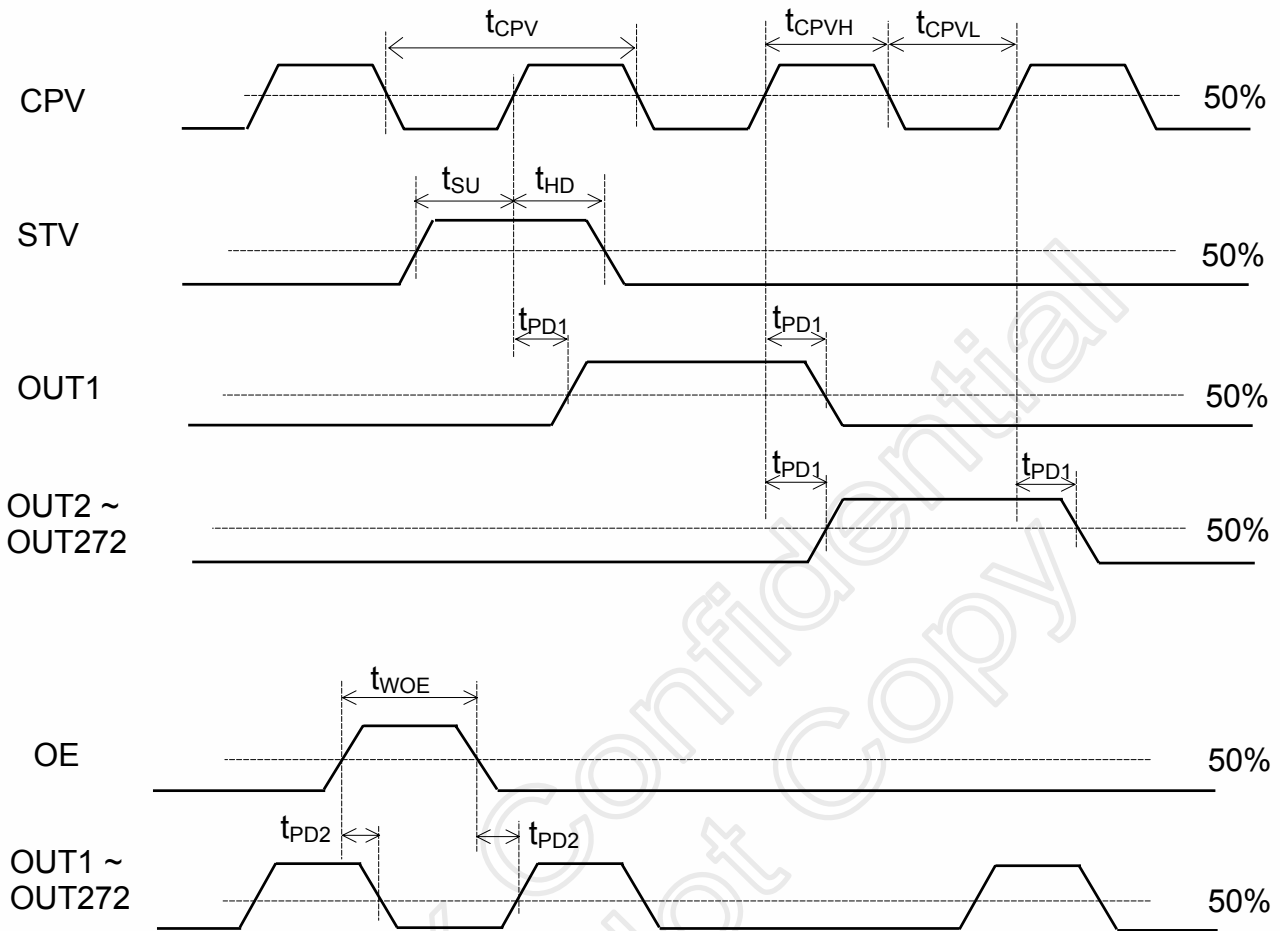

9. Pad Coordinate

9.1 HX8655-A Gate Driver Bump Location

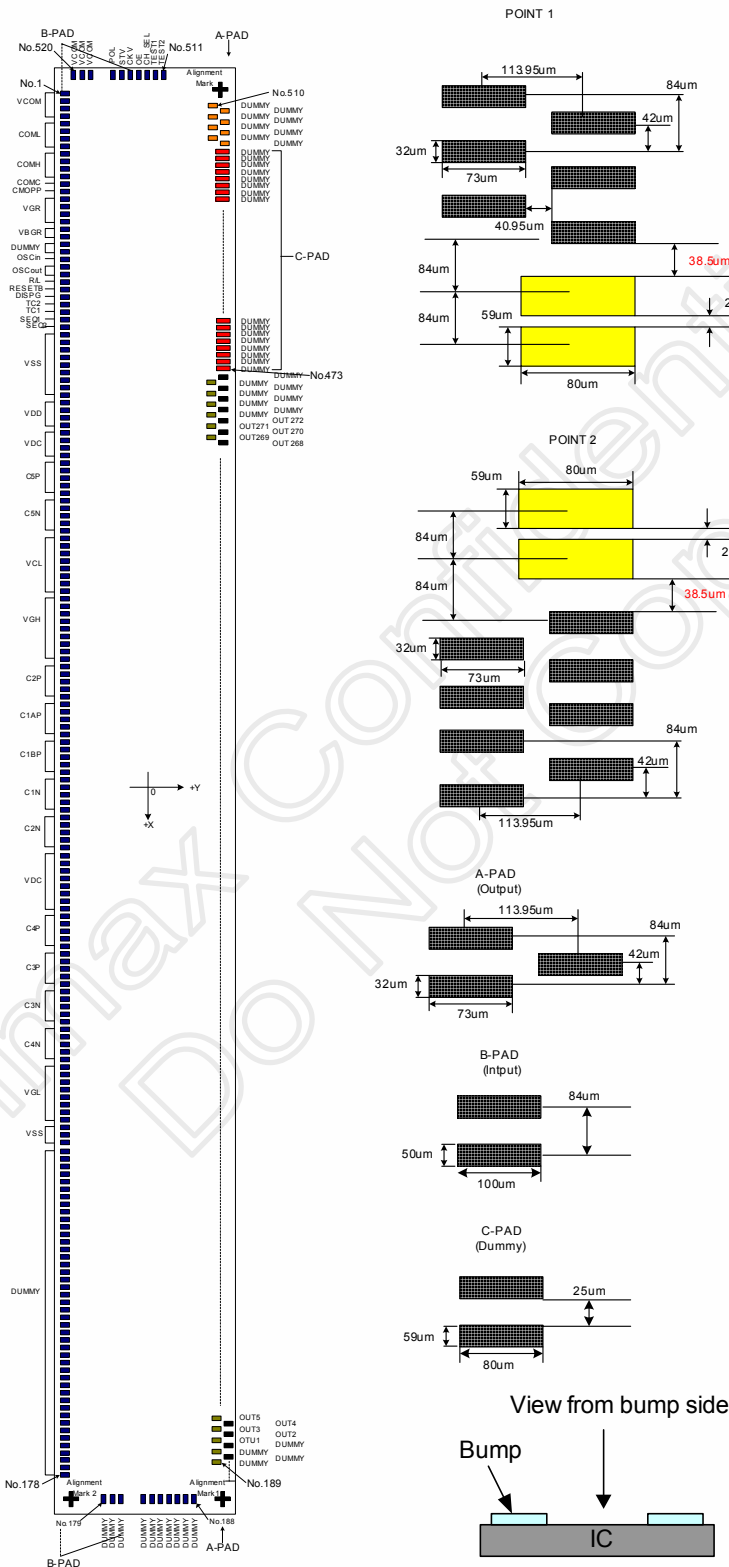

Chip size: 15545 μ m x 1680 μ m (scribe line included)

Bump height: 15 μ m \pm 3 μ m

Bump hardness: 60Hv \pm 15Hv

Scribe line width: 100 μ m

Himax Confidential

This information contained herein is the exclusive property of Himax and shall not be distributed, reproduced, or disclosed in whole or in part without prior written permission of Himax. **Subject to change without notice.**



9.2 Alignment Mark

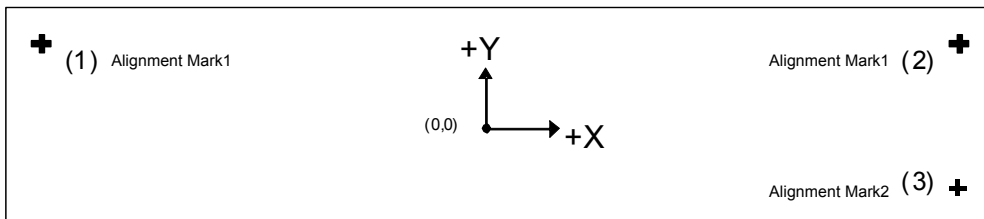

(1) (X,Y) = (7581, 651)

(2) (X,Y) = (-7581, 651)

Alignment Mark1

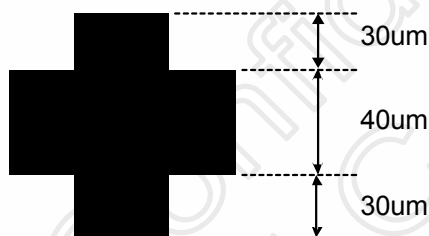

(3) (X,Y) = (7665, -735)

Alignment Mark2

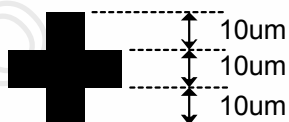

9.3 Bump center coordinate (Reference 9.1)

No.	Name	X	Y	bump size(μm)
1	VCOM	-7434	-708	B
2	VCOM	-7350	-708	B
3	VCOM	-7266	-708	B
4	VCOM	-7182	-708	B
5	COML	-7098	-708	B
6	COML	-7014	-708	B
7	COML	-6930	-708	B
8	COML	-6846	-708	B
9	COMH	-6762	-708	B
10	COMH	-6678	-708	B
11	COMH	-6594	-708	B
12	COMH	-6510	-708	B
13	COMC	-6426	-708	B
14	COMPP	-6342	-708	B
15	VGR	-6258	-708	B
16	VGR	-6174	-708	B
17	VGR	-6090	-708	B
18	VGR	-6006	-708	B
19	VBGR	-5922	-708	B
20	VBGR	-5838	-708	B
21	DUMMY	-5754	-708	B
22	DUMMY	-5670	-708	B
23	OSCIN	-5586	-708	B
24	OSCOUT	-5502	-708	B
25	OSCOUT	-5418	-708	B
26	L/R	-5334	-708	B
27	RESETB	-5250	-708	B
28	DISPG	-5166	-708	B
29	TC2	-5082	-708	B
30	TC1	-4998	-708	B
31	SEQ1	-4914	-708	B
32	SEQ2	-4830	-708	B
33	VSS	-4746	-708	B
34	VSS	-4662	-708	B
35	VSS	-4578	-708	B
36	VSS	-4494	-708	B
37	VSS	-4410	-708	B
38	VSS	-4326	-708	B
39	VSS	-4242	-708	B
40	VSS	-4158	-708	B
41	VSS	-4074	-708	B
42	VDD	-3990	-708	B
43	VDD	-3906	-708	B
44	VDD	-3822	-708	B
45	VDD	-3738	-708	B
46	VDC	-3654	-708	B
47	VDC	-3570	-708	B
48	VDC	-3486	-708	B
49	VDC	-3402	-708	B
50	C5P	-3318	-708	B
51	C5 P	-3234	-708	B
52	C5 P	-3150	-708	B
53	C5 P	-3066	-708	B
54	C5 P	-2982	-708	B
55	C5N	-2898	-708	B
56	C5N	-2814	-708	B
57	C5N	-2730	-708	B
58	C5N	-2646	-708	B
59	C5N	-2562	-708	B
60	VCL	-2478	-708	B

No.	Name	X	Y	bump size(μm)
61	VCL	-2394	-708	B
62	VCL	-2310	-708	B
63	VCL	-2226	-708	B
64	VCL	-2142	-708	B
65	VCL	-2058	-708	B
66	VCL	-1974	-708	B
67	VCL	-1890	-708	B
68	VGH	-1806	-708	B
69	VGH	-1722	-708	B
70	VGH	-1638	-708	B
71	VGH	-1554	-708	B
72	VGH	-1470	-708	B
73	VGH	-1386	-708	B
74	VGH	-1302	-708	B
75	VGH	-1218	-708	B
76	VGH	-1134	-708	B
77	C2P	-1050	-708	B
78	C2P	-966	-708	B
79	C2P	-882	-708	B
80	C2P	-798	-708	B
81	C2P	-714	-708	B
82	C1AP	-630	-708	B
83	C1AP	-546	-708	B
84	C1AP	-462	-708	B
85	C1AP	-378	-708	B
86	C1AP	-294	-708	B
87	C1BP	-210	-708	B
88	C1BP	-126	-708	B
89	C1BP	-42	-708	B
90	C1BP	42	-708	B
91	C1BP	126	-708	B
92	C1N	210	-708	B
93	C1N	294	-708	B
94	C1N	378	-708	B
95	C1N	462	-708	B
96	C1N	546	-708	B
97	C2N	630	-708	B
98	C2N	714	-708	B
99	C2N	798	-708	B
100	C2N	882	-708	B
101	C2N	966	-708	B
102	VDC	1050	-708	B
103	VDC	1134	-708	B
104	VDC	1218	-708	B
105	VDC	1302	-708	B
106	VDC	1386	-708	B
107	VDC	1470	-708	B
108	VDC	1554	-708	B
109	VDC	1638	-708	B
110	C4P	1722	-708	B
111	C4P	1806	-708	B
112	C4P	1890	-708	B
113	C4P	1974	-708	B
114	C4P	2058	-708	B
115	C3P	2142	-708	B
116	C3P	2226	-708	B
117	C3P	2310	-708	B
118	C3P	2394	-708	B
119	C3P	2478	-708	B
120	C3N	2562	-708	B



No.	Name	X	Y	bump size(μm)
121	C3N	2646	-708	B
122	C3N	2730	-708	B
123	C3N	2814	-708	B
124	C3N	2898	-708	B
125	C4N	2982	-708	B
126	C4N	3066	-708	B
127	C4N	3150	-708	B
128	C4N	3234	-708	B
129	C4N	3318	-708	B
130	VGL	3402	-708	B
131	VGL	3486	-708	B
132	VGL	3570	-708	B
133	VGL	3654	-708	B
134	VGL	3738	-708	B
135	VGL	3822	-708	B
136	VGL	3906	-708	B
137	VGL	3990	-708	B
138	VSS	4074	-708	B
139	VSS	4158	-708	B
140	VSS	4242	-708	B
141	DUMMY	4326	-708	B
142	DUMMY	4410	-708	B
143	DUMMY	4494	-708	B
144	DUMMY	4578	-708	B
145	DUMMY	4662	-708	B
146	DUMMY	4746	-708	B
147	DUMMY	4830	-708	B
148	DUMMY	4914	-708	B
149	DUMMY	4998	-708	B
150	DUMMY	5082	-708	B
151	DUMMY	5166	-708	B
152	DUMMY	5250	-708	B
153	DUMMY	5334	-708	B
154	DUMMY	5418	-708	B
155	DUMMY	5502	-708	B
156	DUMMY	5586	-708	B
157	DUMMY	5670	-708	B
158	DUMMY	5754	-708	B
159	DUMMY	5838	-708	B
160	DUMMY	5922	-708	B
161	DUMMY	6006	-708	B
162	DUMMY	6090	-708	B
163	DUMMY	6174	-708	B
164	DUMMY	6258	-708	B
165	DUMMY	6342	-708	B
166	DUMMY	6426	-708	B
167	DUMMY	6510	-708	B
168	DUMMY	6594	-708	B
169	DUMMY	6678	-708	B
170	DUMMY	6762	-708	B
171	DUMMY	6846	-708	B
172	DUMMY	6930	-708	B
173	DUMMY	7014	-708	B
174	DUMMY	7098	-708	B
175	DUMMY	7182	-708	B
176	DUMMY	7266	-708	B
177	DUMMY	7350	-708	B
178	DUMMY	7434	-708	B
179	DUMMY	7638	-588	B
180	DUMMY	7638	-504	B

No.	Name	X	Y	bump size(μm)
181	DUMMY	7638	-420	B
182	DUMMY	7638	-168	B
183	DUMMY	7638	-84	B
184	DUMMY	7638	0	B
185	DUMMY	7638	84	B
186	DUMMY	7638	168	B
187	DUMMY	7638	252	B
188	DUMMY	7638	336	B
189	DUMMY	7392	602.05	A
190	DUMMY	7350	716	A
191	DUMMY	7308	602.05	A
192	DUMMY	7266	716	A
193	OUT1	7224	602.05	A
194	OUT2	7182	716	A
195	OUT3	7140	602.05	A
196	OUT4	7098	716	A
197	OUT5	7056	602.05	A
198	OUT6	7014	716	A
199	OUT7	6972	602.05	A
200	OUT8	6930	716	A
201	OUT9	6888	602.05	A
202	OUT10	6846	716	A
203	OUT11	6804	602.05	A
204	OUT12	6762	716	A
205	OUT13	6720	602.05	A
206	OUT14	6678	716	A
207	OUT15	6636	602.05	A
208	OUT16	6594	716	A
209	OUT17	6552	602.05	A
210	OUT18	6510	716	A
211	OUT19	6468	602.05	A
212	OUT20	6426	716	A
213	OUT21	6384	602.05	A
214	OUT22	6342	716	A
215	OUT23	6300	602.05	A
216	OUT24	6258	716	A
217	OUT25	6216	602.05	A
218	OUT26	6174	716	A
219	OUT27	6132	602.05	A
220	OUT28	6090	716	A
221	OUT29	6048	602.05	A
222	OUT30	6006	716	A
223	OUT31	5964	602.05	A
224	OUT32	5922	716	A
225	OUT33	5880	602.05	A
226	OUT34	5838	716	A
227	OUT35	5796	602.05	A
228	OUT36	5754	716	A
229	OUT37	5712	602.05	A
230	OUT38	5670	716	A
231	OUT39	5628	602.05	A
232	OUT40	5586	716	A
233	OUT41	5544	602.05	A
234	OUT42	5502	716	A
235	OUT43	5460	602.05	A
236	OUT44	5418	716	A
237	OUT45	5376	602.05	A
238	OUT46	5334	716	A
239	OUT47	5292	602.05	A
240	OUT48	5250	716	A

Himax/奇景光電
2006.11.15
文件管制中心DCC

No.	Name	X	Y	bump size(μm)
241	OUT49	5208	602.05	A
242	OUT50	5166	716	A
243	OUT51	5124	602.05	A
244	OUT52	5082	716	A
245	OUT53	5040	602.05	A
246	OUT54	4998	716	A
247	OUT55	4956	602.05	A
248	OUT56	4914	716	A
249	OUT57	4872	602.05	A
250	OUT58	4830	716	A
251	OUT59	4788	602.05	A
252	OUT60	4746	716	A
253	OUT61	4704	602.05	A
254	OUT62	4662	716	A
255	OUT63	4620	602.05	A
256	OUT64	4578	716	A
257	OUT65	4536	602.05	A
258	OUT66	4494	716	A
259	OUT67	4452	602.05	A
260	OUT68	4410	716	A
261	OUT69	4368	602.05	A
262	OUT70	4326	716	A
263	OUT71	4284	602.05	A
264	OUT72	4242	716	A
265	OUT73	4200	602.05	A
266	OUT74	4158	716	A
267	OUT75	4116	602.05	A
268	OUT76	4074	716	A
269	OUT77	4032	602.05	A
270	OUT78	3990	716	A
271	OUT79	3948	602.05	A
272	OUT80	3906	716	A
273	OUT81	3864	602.05	A
274	OUT82	3822	716	A
275	OUT83	3780	602.05	A
276	OUT84	3738	716	A
277	OUT85	3696	602.05	A
278	OUT86	3654	716	A
279	OUT87	3612	602.05	A
280	OUT88	3570	716	A
281	OUT89	3528	602.05	A
282	OUT90	3486	716	A
283	OUT91	3444	602.05	A
284	OUT92	3402	716	A
285	OUT93	3360	602.05	A
286	OUT94	3318	716	A
287	OUT95	3276	602.05	A
288	OUT96	3234	716	A
289	OUT97	3192	602.05	A
290	OUT98	3150	716	A
291	OUT99	3108	602.05	A
292	OUT100	3066	716	A
293	OUT101	3024	602.05	A
294	OUT102	2982	716	A
295	OUT103	2940	602.05	A
296	OUT104	2898	716	A
297	OUT105	2856	602.05	A
298	OUT106	2814	716	A
299	OUT107	2772	602.05	A
300	OUT108	2730	716	A

No.	Name	X	Y	bump size(μm)
301	OUT109	2688	602.05	A
302	OUT110	2646	716	A
303	OUT111	2604	602.05	A
304	OUT112	2562	716	A
305	OUT113	2520	602.05	A
306	OUT114	2478	716	A
307	OUT115	2436	602.05	A
308	OUT116	2394	716	A
309	OUT117	2352	602.05	A
310	OUT118	2310	716	A
311	OUT119	2268	602.05	A
312	OUT120	2226	716	A
313	OUT121	2184	602.05	A
314	OUT122	2142	716	A
315	OUT123	2100	602.05	A
316	OUT124	2058	716	A
317	OUT125	2016	602.05	A
318	OUT126	1974	716	A
319	OUT127	1932	602.05	A
320	OUT128	1890	716	A
321	OUT129	1848	602.05	A
322	OUT130	1806	716	A
323	OUT131	1764	602.05	A
324	OUT132	1722	716	A
325	OUT133	1680	602.05	A
326	OUT134	1638	716	A
327	OUT135	1596	602.05	A
328	OUT136	1554	716	A
329	OUT137	1512	602.05	A
330	OUT138	1470	716	A
331	OUT139	1428	602.05	A
332	OUT140	1386	716	A
333	OUT141	1344	602.05	A
334	OUT142	1302	716	A
335	OUT143	1260	602.05	A
336	OUT144	1218	716	A
337	OUT145	1176	602.05	A
338	OUT146	1134	716	A
339	OUT147	1092	602.05	A
340	OUT148	1050	716	A
341	OUT149	1008	602.05	A
342	OUT150	966	716	A
343	OUT151	924	602.05	A
344	OUT152	882	716	A
345	OUT153	840	602.05	A
346	OUT154	798	716	A
347	OUT155	756	602.05	A
348	OUT156	714	716	A
349	OUT157	672	602.05	A
350	OUT158	630	716	A
351	OUT159	588	602.05	A
352	OUT160	546	716	A
353	OUT161	504	602.05	A
354	OUT162	462	716	A
355	OUT163	420	602.05	A
356	OUT164	378	716	A
357	OUT165	336	602.05	A
358	OUT166	294	716	A
359	OUT167	252	602.05	A
360	OUT168	210	716	A

No.	Name	X	Y	bump size(μm)
361	OUT169	168	602.05	A
362	OUT170	126	716	A
363	OUT171	84	602.05	A
364	OUT172	42	716	A
365	OUT173	0	602.05	A
366	OUT174	-42	716	A
367	OUT175	-84	602.05	A
368	OUT176	-126	716	A
369	OUT177	-168	602.05	A
370	OUT178	-210	716	A
371	OUT179	-252	602.05	A
372	OUT180	-294	716	A
373	OUT181	-336	602.05	A
374	OUT182	-378	716	A
375	OUT183	-420	602.05	A
376	OUT184	-462	716	A
377	OUT185	-504	602.05	A
378	OUT186	-546	716	A
379	OUT187	-588	602.05	A
380	OUT188	-630	716	A
381	OUT189	-672	602.05	A
382	OUT190	-714	716	A
383	OUT191	-756	602.05	A
384	OUT192	-798	716	A
385	OUT193	-840	602.05	A
386	OUT194	-882	716	A
387	OUT195	-924	602.05	A
388	OUT196	-966	716	A
389	OUT197	-1008	602.05	A
390	OUT198	-1050	716	A
391	OUT199	-1092	602.05	A
392	OUT200	-1134	716	A
393	OUT201	-1176	602.05	A
394	OUT202	-1218	716	A
395	OUT203	-1260	602.05	A
396	OUT204	-1302	716	A
397	OUT205	-1344	602.05	A
398	OUT206	-1386	716	A
399	OUT207	-1428	602.05	A
400	OUT208	-1470	716	A
401	OUT209	-1512	602.05	A
402	OUT210	-1554	716	A
403	OUT211	-1596	602.05	A
404	OUT212	-1638	716	A
405	OUT213	-1680	602.05	A
406	OUT214	-1722	716	A
407	OUT215	-1764	602.05	A
408	OUT216	-1806	716	A
409	OUT217	-1848	602.05	A
410	OUT218	-1890	716	A
411	OUT219	-1932	602.05	A
412	OUT220	-1974	716	A
413	OUT221	-2016	602.05	A
414	OUT222	-2058	716	A
415	OUT223	-2100	602.05	A
416	OUT224	-2142	716	A
417	OUT225	-2184	602.05	A
418	OUT226	-2226	716	A
419	OUT227	-2268	602.05	A
420	OUT228	-2310	716	A

No.	Name	X	Y	bump size(μm)
421	OUT229	-2352	602.05	A
422	OUT230	-2394	716	A
423	OUT231	-2436	602.05	A
424	OUT232	-2478	716	A
425	OUT233	-2520	602.05	A
426	OUT234	-2562	716	A
427	OUT235	-2604	602.05	A
428	OUT236	-2646	716	A
429	OUT237	-2688	602.05	A
430	OUT238	-2730	716	A
431	OUT239	-2772	602.05	A
432	OUT240	-2814	716	A
433	OUT241	-2856	602.05	A
434	OUT242	-2898	716	A
435	OUT243	-2940	602.05	A
436	OUT244	-2982	716	A
437	OUT245	-3024	602.05	A
438	OUT246	-3066	716	A
439	OUT247	-3108	602.05	A
440	OUT248	-3150	716	A
441	OUT249	-3192	602.05	A
442	OUT250	-3234	716	A
443	OUT251	-3276	602.05	A
444	OUT252	-3318	716	A
445	OUT253	-3360	602.05	A
446	OUT254	-3402	716	A
447	OUT255	-3444	602.05	A
448	OUT256	-3486	716	A
449	OUT257	-3528	602.05	A
450	OUT258	-3570	716	A
451	OUT259	-3612	602.05	A
452	OUT260	-3654	716	A
453	OUT261	-3696	602.05	A
454	OUT262	-3738	716	A
455	OUT263	-3780	602.05	A
456	OUT264	-3822	716	A
457	OUT265	-3864	602.05	A
458	OUT266	-3906	716	A
459	OUT267	-3948	602.05	A
460	OUT268	-3990	716	A
461	OUT269	-4032	602.05	A
462	OUT270	-4074	716	A
463	OUT271	-4116	602.05	A
464	OUT272	-4158	716	A
465	DUMMY	-4200	602.05	A
466	DUMMY	-4242	716	A
467	DUMMY	-4284	602.05	A
468	DUMMY	-4326	716	A
469	DUMMY	-4368	602.05	A
470	DUMMY	-4410	716	A
471	DUMMY	-4452	602.05	A
472	DUMMY	-4494	716	A
473	DUMMY	-4578	712.5	C
474	DUMMY	-4662	712.5	C
475	DUMMY	-4746	712.5	C
476	DUMMY	-4830	712.5	C
477	DUMMY	-4914	712.5	C
478	DUMMY	-4998	712.5	C
479	DUMMY	-5082	712.5	C
480	DUMMY	-5166	712.5	C

No.	Name	X	Y	bump size(μm)
481	DUMMY	-5250	712.5	C
482	DUMMY	-5334	712.5	C
483	DUMMY	-5418	712.5	C
484	DUMMY	-5502	712.5	C
485	DUMMY	-5586	712.5	C
486	DUMMY	-5670	712.5	C
487	DUMMY	-5754	712.5	C
488	DUMMY	-5838	712.5	C
489	DUMMY	-5922	712.5	C
490	DUMMY	-6006	712.5	C
491	DUMMY	-6090	712.5	C
492	DUMMY	-6174	712.5	C
493	DUMMY	-6258	712.5	C
494	DUMMY	-6342	712.5	C
495	DUMMY	-6426	712.5	C
496	DUMMY	-6510	712.5	C
497	DUMMY	-6594	712.5	C
498	DUMMY	-6678	712.5	C
499	DUMMY	-6762	712.5	C
500	DUMMY	-6846	712.5	C
501	DUMMY	-6930	712.5	C
502	DUMMY	-7014	712.5	C
503	DUMMY	-7098	716	A
504	DUMMY	-7140	602.05	A
505	DUMMY	-7182	716	A
506	DUMMY	-7224	602.05	A
507	DUMMY	-7266	716	A
508	DUMMY	-7308	602.05	A
509	DUMMY	-7350	716	A
510	DUMMY	-7392	602.05	A
511	TEST2	-7638	336	B
512	TEST1	-7638	252	B
513	CH_SEL	-7638	168	B
514	OE	-7638	84	B
515	CPV	-7638	0	B
516	STV	-7638	-84	B
517	POL	-7638	-168	B
518	VCOM	-7638	-420	B
519	VCOM	-7638	-504	B
520	VCOM	-7638	-588	B

Alignment Mark (1)	-7581	651
	7581	651
Alignment Mark (2)	7665	-735



10. Ordering Information

Part No.	Package
HX8655-A000PDxxx	PD : mean COG xxx : mean chip thickness (μm) , (default 400 μm)

11. Revision History

VERSION	EFF.DATE	DESCRIPTION OF CHANGES
01	2005/04/18	New setup
02	2005/10/01	Page 8 Adding 5.11 DC/ DC external component Page 9 Adding 5.12 Regulator for Gamma circuit of source driver Page 10 Adding 5.13 Value of wiring resistance to each pin
	2005/10/04	Page 16 Modify 9.2 alignment mark center coordinate figure sign
	2005/12/01	Page 10 Adding 5.13 input signal wiring resistance Page 11 Change VDD maximum voltage
	2005/12/06	Page 2 CH3. block diagram: be added capacitor polarity Page 6 CH5.4 power on/off: be added DISPG signal Page 8 CH5.11 DC/DC external component : be added capacitor polarity
	2005/12/16	Page 12 Revise power consumption condition
03	2006/04/21	All pages Remove 'preliminary' wording from the data sheet Page 13 Add oscillation frequency and VCOM rise/fall time Page 15 Modify chip size

