



HIGH-VOLTAGE MIXED-SIGNAL IC

UC1608

128COM x 240SEG Matrix LCD Controller-Driver

MP Specifications
Revision 1.1

November 4, 2004

ULTRACHIP

The Coolest LCD Driver. Ever!!

TABLE OF CONTENT

INTRODUCTION	1
ORDERING INFORMATION	2
BLOCK DIAGRAM.....	3
PIN DESCRIPTION.....	4
REFERENCE COG LAYOUT.....	7
CONTROL REGISTERS.....	8
COMMAND TABLE.....	10
COMMAND DESCRIPTION	11
LCD VOLTAGE SETTING	16
V_{LCD} QUICK REFERENCE.....	17
LCD DISPLAY CONTROLS.....	20
ITO LAYOUT CONSIDERATIONS	21
HOST INTERFACE.....	23
DISPLAY DATA RAM.....	30
RESET & POWER MANAGEMENT.....	33
SAMPLE POWER COMMAND SEQUENCES	35
ABSOLUTE MAXIMUM RATINGS.....	37
SPECIFICATIONS	38
AC CHARACTERISTICS	39
PHYSICAL DIMENSIONS.....	44
ALIGNMENT MARK INFORMATION.....	45
PAD COORDINATES	46
TRAY INFORMATION	50
COF INFORMATION.....	51
REVISION HISTORY	53

UC1608

*Single-Chip, Ultra-Low Power
128COM x 240SEG Matrix
Passive LCD Controller-Driver*

INTRODUCTION

UC1608 is an advanced high-voltage mixed-signal CMOS IC, especially designed for the display needs of ultra-low power hand-held devices.

This chip employs UltraChip's unique DCC (Direct Capacitor Coupling) driver architecture to achieve near crosstalk free images.

In addition to low power COM and SEG drivers, UC1608 contains all necessary circuits for high-V LCD power supply, bias voltage generation, timing generation and graphics data memory.

Advanced circuit design techniques are employed to minimize external component counts and reduce connector size while achieving extremely low power consumption.

MAIN APPLICATIONS

- Cellular Phones, Smart Phones, PDA and other battery operated palm top devices and/or portable Instruments

FEATURE HIGHLIGHTS

- Single chip controller-driver supports 128 COM x 240 SEG LCD, with vertical scroll.
- Support both row ordered and column ordered display buffer RAM access.

- Support industry standard 3-wire, 4-wire serial bus (S9, S8, S8uc) and 8-bit/4-bit parallel bus (8080 or 6800).
- Support two multiplexing rates (128, 96).
- Self-configuring 8x charge pump with on-chip pumping capacitor requires only 3 external capacitors to operate.
- Flexible data addressing/mapping schemes to support wide ranges of software models and LCD layout placements.
- Software programmable 4 temperature compensation coefficients.
- On-chip Power-ON Reset and Software RESET commands, make RST pin optional.
- Many on-chip and I/O pad layout features to support optimized COG applications.
- V_{DD} (digital) range: 2.7V ~ 3.3V
 V_{DD} (analog) range: 2.7V ~ 3.3V
LCD V_{OP} range: 11.3V ~ 16V
- Available in gold bump dies
Bump pitch: 45 μ M min.
Bump gap: 18 μ M min.
Bump surface: > 3000 μ M²

ORDERING INFORMATION

Product ID	Description
UC1608xGBE	Gold bumped die.
UC1608xFBE	COF packaging.

General Notes**APPLICATION INFORMATION**

For improved readability, the specification contains many application data points. When application information is given, it is advisory and does not form part of the specification for the device.

BARE DIE DISCLAIMER

All die are tested and are guaranteed to comply with all data sheet limits up to the point of wafer sawing for a period of ninety (90) days from the date of UltraChip's delivery. There is no post wafer saw/pack testing performed on individual die. Although the latest modern processes are utilized for wafer sawing and die pick-&-place into wafer pack carriers, UltraChip has no control of third party procedures in the handling, packing or assembly of the die. Accordingly, it is the responsibility of the customer to test and qualify their application in which the die is to be used. UltraChip assumes no liability for device functionality or performance of the die or systems after handling, packing or assembly of the die.

LIFE SUPPORT APPLICATIONS

These devices are not designed for use in life support appliances, or systems where malfunction of these products can reasonably be expected to result in personal injuries. Customer using or selling these products for use in such applications do so at their own risk.

CONTENT DISCLAIMER

UltraChip believes the information contained in this document to be accurate and reliable. However, it is subject to change without notice. No responsibility is assumed by UltraChip for its use, nor for infringement of patents or other rights of third parties. No part of this publication may be reproduced, or transmitted in any form or by any means without the prior consent of UltraChip Inc. UltraChip's terms and conditions of sale apply at all times.

CONTACT INFORMATION

UltraChip Inc. (Headquarter)
2F, No. 70, Chowtze Street,
Nei Hu District, Taipei 114,
Taiwan, R. O. C.

Tel: +886 (2) 8797-8947
Fax: +886 (2) 8797-8910
Sales e-mail: sales@ultrachip.com
Web site: <http://www.ultrachip.com>

BLOCK DIAGRAM

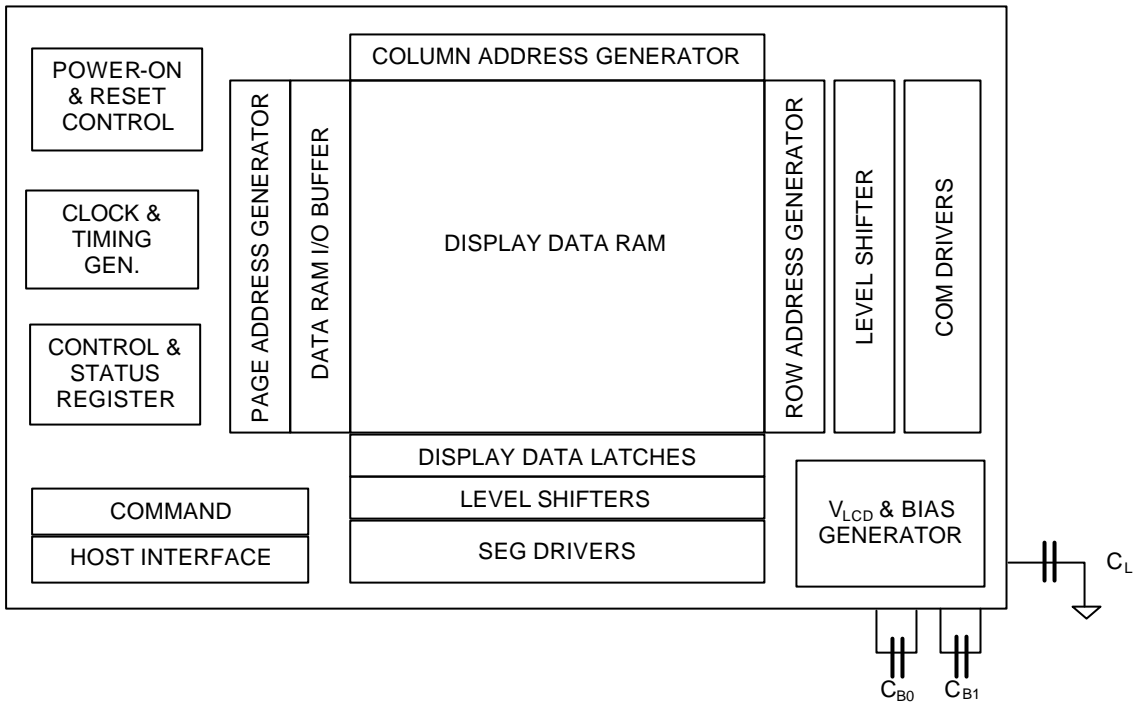

PIN DESCRIPTION

Name	Type	Pins	Description
MAIN POWER SUPPLY			
V _{DD} V _{DD2} V _{DD3}	PWR	5 5 3	V _{DD} is the digital V _{DD} . V _{DD2} /V _{DD3} is the analog power supply and it should be connected to the same power source. V _{DD} supplies for digital logic and display data RAM. V _{DD2} supplies for V _{LCD} and V _{BIAS} generator, V _{DD3} supplies for other analog circuits. Please maintain the following relationship: $V_{DD} + 1.3V \geq V_{DD2/3} \geq V_{DD}$ Minimize the trace resistance for V _{DD} and V _{DD2} /V _{DD3} .
V _{SS} V _{SS2}	GND	4 5	Ground. Connect V _{SS} and V _{SS2} to the shared GND pin. Minimize the trace resistance for V _{SS} and V _{SS2} .
LCD POWER SUPPLY			
V _{BIAS}	I	1	This is the reference voltage to generate the actual SEG driving voltage. V _{BIAS} can be used to fine tune V _{LCD} by external variable resistors. Internal resistor network has been provided to simplify external trimming circuit. In COF application, connect a small bypass capacitor between V _{BIAS} and V _{SS} to reduce noise.
V _{B1+} V _{B1-} V _{B0+} V _{B0-}	PWR	6 6 4 6	LCD Bias Voltages. These are the voltage source to provide SEG driving currents. These voltages are generated internally. Connect capacitors of C _{BX} value between V _{BX+} and V _{BX-} . The resistance of these four traces directly affects the SEG driving strength of the resulting LCD module. Minimize the trace resistance is critical in achieving high quality image.
V _{LCDIN} V _{LCDOUT}	PWR	2 2	Main LCD Power Supply. Connect these pins together. A by-pass capacitor C _L is optional. When C _L is used, connect C _L between V _{LCD} and V _{SS} , and keep the trace resistance under 300 .

Note:

Recommended capacitor values:

C_B: 150~250x LCD load capacitance or 4.7μF (2V), whichever is higher.

C_L: 50nF ~ 0.1μF (25V) is appropriate for most applications.

Name	Type	Pins	Description																																													
HOST INTERFACE																																																
BM[1:0]	I	2	<p>Bus mode: The interface bus mode is determined by BM[1:0] and D[7:6] by the following relationship:</p> <table border="1"> <thead> <tr> <th>BM[1:0]</th> <th>D[7:6]</th> <th>Mode</th> </tr> </thead> <tbody> <tr> <td>11</td> <td>Data</td> <td>6800/8-bit</td> </tr> <tr> <td>10</td> <td>Data</td> <td>8080/8-bit</td> </tr> <tr> <td>01</td> <td>0X</td> <td>6800/4-bit</td> </tr> <tr> <td>00</td> <td>0X</td> <td>8080/4-bit</td> </tr> <tr> <td>01</td> <td>10</td> <td>3-wire SPI w/ 9-bit token (S9: conventional)</td> </tr> <tr> <td>00</td> <td>10</td> <td>4-wire SPI w/ 8-bit token (S8: conventional)</td> </tr> <tr> <td>00</td> <td>11</td> <td>3/4-wire SPI w/ 8-bit token (S8uc: Ultra-Compact)</td> </tr> </tbody> </table>	BM[1:0]	D[7:6]	Mode	11	Data	6800/8-bit	10	Data	8080/8-bit	01	0X	6800/4-bit	00	0X	8080/4-bit	01	10	3-wire SPI w/ 9-bit token (S9: conventional)	00	10	4-wire SPI w/ 8-bit token (S8: conventional)	00	11	3/4-wire SPI w/ 8-bit token (S8uc: Ultra-Compact)																					
BM[1:0]	D[7:6]	Mode																																														
11	Data	6800/8-bit																																														
10	Data	8080/8-bit																																														
01	0X	6800/4-bit																																														
00	0X	8080/4-bit																																														
01	10	3-wire SPI w/ 9-bit token (S9: conventional)																																														
00	10	4-wire SPI w/ 8-bit token (S8: conventional)																																														
00	11	3/4-wire SPI w/ 8-bit token (S8uc: Ultra-Compact)																																														
CS	I	1	Chip Select. The chip is selected when CS="H". When the chip is not selected, D[7:0] will be high impedance.																																													
RST	I	1	When RST="L", all control registers are re-initialized by their default states. Since UC1608 has built-in Power-ON-Reset and Software Reset command, RST pin is not required for proper chip operation. When RST is not used, connect the pin to V _{DD} .																																													
CD	I	1	Select Control data or Display data for read/write operation. In S9 mode, CD pin is not used. Connect CD to V _{SS} when not used. "L": Control data "H": Display data																																													
WR0 WR1	I	2	WR[1:0] controls the read/write operation of the host interface. See Host Interface section for more detail. In parallel mode, WR[1:0] meaning depends on whether the interface is in the 6800 mode or the 8080 mode. In serial interface modes, these two pins are not used, connect them to V _{SS} .																																													
D0~D7	I/O	8	<p>Bi-directional bus for both serial and parallel host interfaces. In serial modes, connect D[0] to SCK, D[3] to SDA,</p> <table border="1"> <thead> <tr> <th></th> <th>BM=1x (Parallel)</th> <th>BM=0x (Parallel)</th> <th>BM=01 (S9)</th> <th>BM=00 (S8/S8uc)</th> </tr> </thead> <tbody> <tr> <td>D0</td> <td>D0</td> <td>D0/D4</td> <td>SCK</td> <td>SCK</td> </tr> <tr> <td>D1</td> <td>D1</td> <td>D1/D5</td> <td>-</td> <td>-</td> </tr> <tr> <td>D2</td> <td>D2</td> <td>D2/D6</td> <td>-</td> <td>-</td> </tr> <tr> <td>D3</td> <td>D3</td> <td>D3/D7</td> <td>SDA</td> <td>SDA</td> </tr> <tr> <td>D4</td> <td>D4</td> <td>-</td> <td>-</td> <td>-</td> </tr> <tr> <td>D5</td> <td>D5</td> <td>-</td> <td>-</td> <td>-</td> </tr> <tr> <td>D6</td> <td>D6</td> <td>-</td> <td>S9</td> <td>S8/S8uc</td> </tr> <tr> <td>D7</td> <td>D7</td> <td>0</td> <td>1</td> <td>1</td> </tr> </tbody> </table> <p>Connect unused pins to V_{DD} or V_{SS}.</p>		BM=1x (Parallel)	BM=0x (Parallel)	BM=01 (S9)	BM=00 (S8/S8uc)	D0	D0	D0/D4	SCK	SCK	D1	D1	D1/D5	-	-	D2	D2	D2/D6	-	-	D3	D3	D3/D7	SDA	SDA	D4	D4	-	-	-	D5	D5	-	-	-	D6	D6	-	S9	S8/S8uc	D7	D7	0	1	1
	BM=1x (Parallel)	BM=0x (Parallel)	BM=01 (S9)	BM=00 (S8/S8uc)																																												
D0	D0	D0/D4	SCK	SCK																																												
D1	D1	D1/D5	-	-																																												
D2	D2	D2/D6	-	-																																												
D3	D3	D3/D7	SDA	SDA																																												
D4	D4	-	-	-																																												
D5	D5	-	-	-																																												
D6	D6	-	S9	S8/S8uc																																												
D7	D7	0	1	1																																												

Name	Type	Pins	Description
LCD DRIVER OUTPUT			
SEG1 ~ SEG240	HV	240	SEG (column) driver outputs. Support up to 240 columns. Leave unused drivers open-circuit.
COM1 ~ COM128	HV	128	COM (row) driver outputs. Support up to 128 rows. When Mux Rate is not 128, please use only COM1~COM(x), x=128, or 96, and leave COM (x+1) ~ COM128 open-circuit.
Misc. PINS			
V _{DDX}		1	Auxiliary V _{DD} . These pins are connected to the main V _{DD} bus on chip, and they are provided to facilitate chip packaging in COG and COF applications. There is no need to connect V _{DDX} to V _{DD} externally. These pins should not be used to provide V _{DD} power to the chip.
TST4	I	1	Test control. Connect to V _{SS} for normal operation.
TST[3:1]	I/O	3	Test I/O pins. Leave these pins open circuit during normal use.
TP[3:1]	I	3	Leave these pins open circuit during normal use.

Note: Several control registers will specify “0 based index” for COM and SEG electrodes. In those situations, COM_X or SEG_X will correspond to index X-1, and the value ranges for those index registers will be 0~127 for COM and 0~239 for SEG.

REFERENCE COG LAYOUT

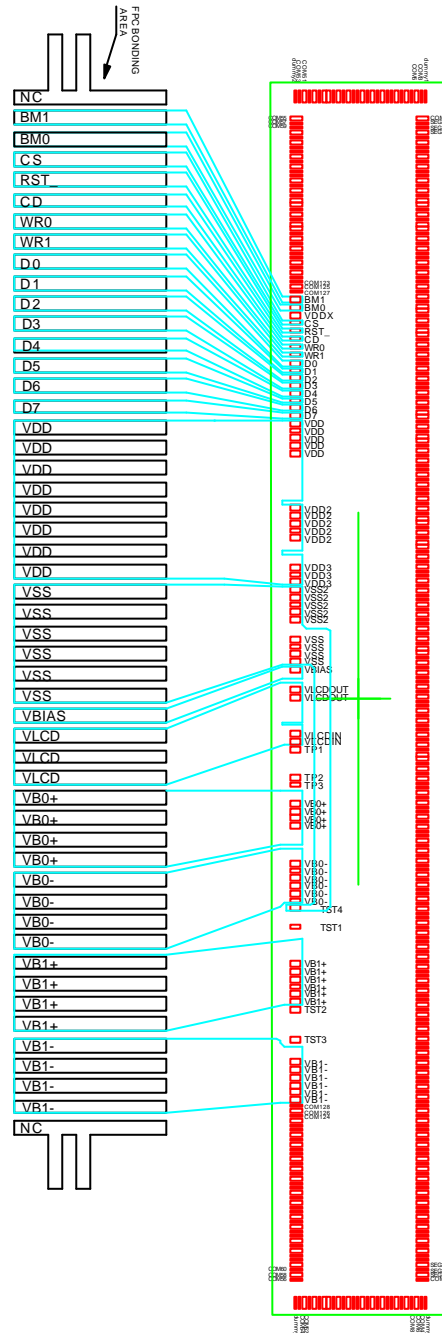

Notes for V_{DD} with COG:

- The typical operation condition of UC1608, V_{DD}=2.7V, should be met under all operating conditions. Unless V_{DD} and V_{DD2/3} ITO trances can each be controlled to be 5Ω or lower; otherwise V_{DD}-V_{DD2/3} separation can cause the actual on-chip V_{DD} to drop below V_{DD}=2.6V during high speed data write condition. Therefore, for COG, V_{DD}-V_{DD2/3} separation requires very careful ITO layout and very stringent testing before MP.
- Keep V_{DD} and V_{SS} under 150Ω.

CONTROL REGISTERS

UC1608 contains registers which control the chip operation. These registers can be modified by commands. The following table is a summary of the control registers, their meaning and their default value. The commands supported by UC1608 are described in the next two sections, first a summary table, followed by a detailed description.

Name: The Symbolic reference of the register byte.
 Note that, some symbol names refer to collection of bits (flags) within one register byte.

Default: Numbers shown in **Bold** fonts are values after *Power-Up-Reset* and *System-Reset*.

Name	Bits	Default	Description
SL	6	0H	Scroll Line. Scroll the displayed image up by SL rows. The valid SL value is between 0 (for no scrolling) and (127– 2xFL). Setting SL outside of this range causes undefined effect on the displayed image.
FL	4	0H	Fixed Lines. The first FLx2 lines of each frame are fixed and are not affected by scrolling (SL). When FL is non-zero, the screen is effectively separated into two regions: one scrollable, one non-scrollable.
CR	8	0H	Return Column Address. Useful for cursor implementation.
CA	8	0H	Display Data RAM Column Address (Used in Host to Display Data RAM access)
PA	4	0H	Display Data RAM Page Address (Used in Host to Display Data RAM access)
BR	2	2H	Bias Ratio. The ratio between V_{LCD} and V_{BIAS} 00b= 10.7 01b= 11.3 10b= 12.0 11b= 12.7
TC	2	0H	Temperature Compensation (per °C). 00b: 0.0% 01b: -0.05% 10b: -0.1% 11b: -0.2%
GN	2	3H	Gain, coarse setting of V_{BIAS} and V_{LCD}
PM	6	0H	Electronic Potentiometer to fine tune V_{BIAS} and V_{LCD}
MR	1	1H	Multiplexing Rate: Number of pixel rows: 0b: 96 1b: 128
OM	2	–	Operating Modes (Read Only) 00b: Reset 01b: (Not used) 10b: Sleep 11b: Normal
BZ	1	–	Busy with internal processes (reset, changing mode, etc.) OK for Display RAM read/write access.
RS	1	–	Reset in progress, Host Interface not ready
PC	3	5H	Power Control. PC[1:0]: Panel Loading 00b: LCD < 26nF 01b: 26nF < LCD < 43nF 10b: 43nF < LCD < 60nF 11b: 60nF < LCD < 90nF For COG module, the ITO substrate for SEG plate and COM routing: 15 /Sq 15nF < LCD < 35nF. 10 /Sq 35nF < LCD < 50nF 7 /Sq 50nF < LCD < 75nF PC[2]: Pump Control 0b: External V_{LCD} 1b: Internal V_{LCD}
DC	3	0H	Display Control: DC[0]: PXV: Pixels Inverse (Default 0: OFF)

Name	Bits	Default	Description
			DC[1]: APO: All Pixels ON (Default 0 : OFF) DC[2]: Display ON/OFF (Default 0 : OFF).
AC	4	1H	Address Control: AC[0]: WA: Automatic column/page Wrap Around (Default 1 : ON) AC[1]: Reserved (always set to 0) AC[2]: PID: PA (page address) auto increment direction (0 : +1 1 : -1) AC[3]: CUM: Cursor update mode, (Default 0 : OFF) when CUM=1, CA increment on write only, wrap around suspended
LC	4	0H	LCD Mapping Control: LC[0]: MSF: MSB First mapping Option (Default 0 : OFF) LC[1]: Reserved (always set to 0) LC[2]: MX, Mirror X (Column sequence inversion) (Default 0 : OFF) LC[3]: MY, Mirror Y (Row sequence inversion) (Default 0 : OFF)
APC0	8	2AH	Advanced Product Configuration. For UltraChip only. Please do not use.
APC1	4	EH	Advanced Product Configuration. For UltraChip only. Please do not use.

COMMAND TABLE

The following is a list of host commands supported by UC1608

C/D: 0: Control, 1: Data
 W/R: 0: Write Cycle, 1: Read Cycle
 # Useful Data bits
 – Don't Care

	Command	C/D	W/R	D7	D6	D5	D4	D3	D2	D1	D0	Action	Default
1	Write Data Byte	1	0	#	#	#	#	#	#	#	#	Write 1 byte	N/A
2	Read Data Byte	1	1	#	#	#	#	#	#	#	#	Read 1 byte	N/A
3	Get Status	0	1	BZ	MX	DE	RS	WA	GN1	GN0	1	Get Status	N/A
4	Set Column Address LSB	0	0	0	0	0	0	#	#	#	#	Set CA[3:0]	0
	Set Column Address MSB	0	0	0	0	0	1	#	#	#	#	Set CA[7:4]	0
5	Set Mux Rate and temperature compensation.	0	0	0	0	1	0	0	#	#	#	Set {MR, TC[1:0]}	MR: 1b TC: 00b
6	Set Power Control	0	0	0	0	1	0	1	#	#	#	Set PC[2:0]	101b
7	Set Adv. Program Control. (double byte command)	0	0	0	0	1	1	0	0	0	R	For UltraChip only. Do not use.	N/A
		0	0	#	#	#	#	#	#	#	#		
8	Set Start Line	0	0	0	1	#	#	#	#	#	#	Set SL[5:0]	0
9	Set Gain and Potentiometer (double-byte command)	0	0	1	0	0	0	0	0	0	1	Set {GN[1:0], PM[5:0]}	GN=3 PM=0
		0	0	#	#	#	#	#	#	#	#		
10	Set RAM Address Control	0	0	1	0	0	0	1	#	#	#	Set AC[2:0]	001b
11	Set All-Pixel-ON	0	0	1	0	1	0	0	1	0	#	Set DC[1]	0=disable
12	Set Inverse Display	0	0	1	0	1	0	0	1	1	#	Set DC[0]	0=disable
13	Set Display Enable	0	0	1	0	1	0	1	1	1	#	Set DC[2]	0=disable
14	Set Fixed Lines	0	0	1	0	0	1	#	#	#	#	Set FL[3:0]	0
15	Set Page Address	0	0	1	0	1	1	#	#	#	#	Set PA[3:0]	0
16	Set LCD Mapping Control	0	0	1	1	0	0	#	#	#	#	Set LC[3:0]	0
17	System Reset	0	0	1	1	1	0	0	0	1	0	System Reset	N/A
18	NOP	0	0	1	1	1	0	0	0	1	1	No operation	N/A
19	Set LCD Bias Ratio	0	0	1	1	1	0	1	0	#	#	Set BR[1:0]	10b=12
20	Reset Cursor Mode	0	0	1	1	1	0	1	1	1	0	AC[3]=0, CA=CR	N/A
21	Set Cursor Mode	0	0	1	1	1	0	1	1	1	1	AC[3]=1, CR=CA	N/A
22	Set Test Control (double byte command)	0	0	1	1	1	0	0	1	TT		For UltraChip only. Do not use.	N/A
		0	0	#	#	#	#	#	#	#	#		

* Other than commands listed above, all other bit patterns may result in undefined behavior.

COMMAND DESCRIPTION

(1) Write data to display memory

Action	C/D	W/R	D7	D6	D5	D4	D3	D2	D1	D0
Write data	1	0	8bits data write to SRAM							

(2) Read data to display memory

Action	C/D	W/R	D7	D6	D5	D4	D3	D2	D1	D0
Read data	1	1	8bits data from SRAM							

Write/Read Data Byte (command 1,2) operations access display buffer RAM based on Page Address (PA) register and Column Address (CA) register. To minimize bus interface cycles, PA and CA will be incremented automatically depending on the setting of Access Control (AC) registers. PA and CA can also be programmed directly by issuing *Set Page Address* and *Set Column Address* commands.

If Wrap-Around (WA) is OFF (AC[0] = 0), CA will stop increasing after reaching the end of page (MC), and system programmers need to set the values of PA and CA explicitly. If WA is ON (AC[0]=1), when CA reaches end of page, CA will be reset to 0 and PA will be increased or decrease by 1, depending on the setting of Page Increment Direction (PID, AC[2]). When PA reaches the boundary of RAM (i.e. PA = 0 or 15), PA will be wrapped around to the other end of RAM and continue.

(3) Get Status

Action	C/D	W/R	D7	D6	D5	D4	D3	D2	D1	D0
Get Status	0	1	BZ	MX	DE	RS	WA	GN1	GN0	1

Status flag definitions:

BZ: Busy with internal process.

MX: Status of register LC[2], mirror X.

DE: Display enable flag. DE=1 when display enabled

RS: Reset in progress. If RS=1, host interface will be inaccessible.

WA: status of register AC[0]. Automatic column/page wrap around.

GN0, 1: GN[1:0]. register Gain

(4) Set Column Address

Action	C/D	W/R	D7	D6	D5	D4	D3	D2	D1	D0
Set Column Address LSB CA[3:0]	0	0	0	0	0	0	CA3	CA2	CA1	CA0
Set Column Address MSB CA[7:4]	0	0	0	0	0	1	CA7	CA6	CA5	CA4

Set the SRAM column address before Write/Read memory from host interface.

CA possible value=**0-239**

(5) Set Multiplex Rate and Temperature Compensation

Action	C/D	W/R	D7	D6	D5	D4	D3	D2	D1	D0
Set Multiplex Rate MR	0	0	0	0	1	0	0	MR	TC1	TC0
Set Temperature Compensation TC[1:0]	0	0	0	0	1	0	0	MR	TC1	TC0

Set the multiplex ratio (number of rows) and temperature compensation.

MUX ratio definition: 0b=96 **1b=128**

Temperature compensation curve definition:

00b= -0.00%/C 01b= -0.05%/C 10b= -0.10%/C 11b= -0.20%/C

(6) Set Power Control

Action	C/D	W/R	D7	D6	D5	D4	D3	D2	D1	D0
Set Panel Loading PC[2:0]	0	0	0	0	1	0	1	PC2	PC1	PC0

Set PC[1:0], according to the capacitance loading of LCD panel.

Panel loading definition:

00b: LCD < 26 nF

01b: 26 nF < LCD < 43 nF

10b: 43 nF < LCD < 60nF

11b: 60nF < LCD < 90 nF

Set PC[2] to program to use internal charge pump of external V_{LCD} source.

Pump control definition:

0b=External V_{LCD}

1b=Internal V_{LCD}

(7) Set Advanced Program Control

Action	C/D	W/R	D7	D6	D5	D4	D3	D2	D1	D0
Set APC[0]	0	0	0	0	1	1	0	0	0	R
(Double byte command)	0	0	APC register parameter							

For UltraChip only. Please Do NOT use.

(8) Set Start Line

Action	C/D	W/R	D7	D6	D5	D4	D3	D2	D1	D0
Set Start Line SL[5:0]	0	0	0	1	SL5	SL4	SL3	SL2	SL1	SL0

Set the start line number

Start line setting will scroll the displayed image up by SL rows. The valid value is between 0 (no scrolling) and 63. One example of the visual effect on LCD is illustrated in the figure below.

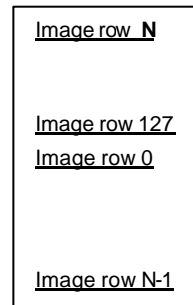
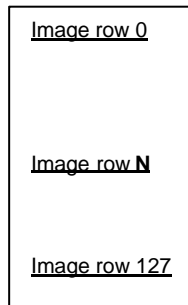

(9) Set Gain and Potentiometer

Action	C/D	W/R	D7	D6	D5	D4	D3	D2	D1	D0
Set Gain and Potentiometer	0	0	1	0	0	0	0	0	0	1
GN [1:0] PM [5:0]	0	0	GN1	GN0	PM5	PM4	PM3	PM2	PM1	PM0
(Double byte command)										

Program Gain (GN[1:0]) and Potentiometer (PM[5:0]). See section LCD VOLTAGE SETTING for more detail.

Effective range of GN = 0 ~ 3

PM value = 0 ~ 63

(10) Set RAM Address Control

Action	C/D	W/R	D7	D6	D5	D4	D3	D2	D1	D0
Set AC [2:0]	0	0	1	0	0	0	1	AC2	AC1	AC0

Program registers AC[2:0] for RAM address control.

AC[0] - WA, Automatic column/page wrap around.

0: CA or PA (depends on AC[1]= 0 or 1) will stop incrementing after reaching boundary

1: CA or PA (depends on AC[1]= 0 or 1) will restart, and PA or CA will increment by one step.

AC[1] – Reserved (always set to 0)

AC[2] – PID, page address (PA) auto increment direction (0/1 = +/- 1)

When WA=1, controls whether page address will be adjusted by +1 or -1, when CA reached CA boundary.

No effect when WA=0.

CA boundary is 239 and PA boundary is 15 when PID=0, PA boundary is 0 when PID=1.

(11) Set All Pixel ON

Action	C/D	W/R	D7	D6	D5	D4	D3	D2	D1	D0
Set All Pixel On DC [1]	0	0	1	0	1	0	0	1	0	DC1

Set DC[1] to force all SEG drivers to output ON signals. This function has no effect on the existing data stored in display RAM.

(12) Set Inverse Display

Action	C/D	W/R	D7	D6	D5	D4	D3	D2	D1	D0
Set Inverse Display DC [0]	0	0	1	0	1	0	0	1	1	DC0

Set DC[0] to force all SEG drivers to output the inverse of the data stored in display memory. This function has no effect on the existing data stored in display RAM.

(13) Set Display Enable

Action	C/D	W/R	D7	D6	D5	D4	D3	D2	D1	D0
Set Display Enable DC[2]	0	0	1	0	1	0	1	1	1	DC2

This command is for programming registers DC[2].

When DC[2] is set to 0, the IC will put itself into Sleep mode. All drivers, voltage generation circuit and timing circuit will be halted to conserve power. When DC[2] is set to 1, UC1608 will first exit from Sleep mode, restore the power and then turn on COM drivers and SEG drivers. There is no other explicit user action or timing sequence required to enter or exit the Sleep mode.

(14) Set Fixed Lines

Action	C/D	W/R	D7	D6	D5	D4	D3	D2	D1	D0
Set Fixed Lines FL [3:0]	0	0	1	0	0	1	FL3	FL2	FL1	FL0

The fixed line function is used to implement the partial scroll function by dividing the screen into scroll and fixed area. Set Fixed Lines command will define the fixed area, which will not be affected by the SL scroll function. The fixed area covers the top 2xFL rows for mirror Y (MY) is 0 and bottom 2xFL rows for MY=1. One example of the visual effect on LCD is illustrated in the figure below.

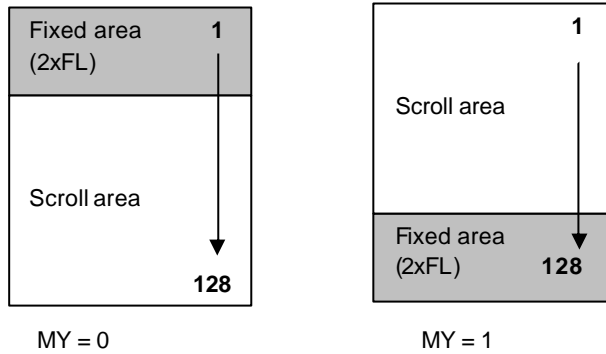

(15) Set Page Address

Action	C/D	W/R	D7	D6	D5	D4	D3	D2	D1	D0
Set Page Address LSB PA [3:0]	0	0	1	0	1	1	PA3	PA2	PA1	PA0

Set the SRAM page address before write/read memory from host interface.
Effective range of value = 0 ~ 15

(16) Set LCD Mapping Control

Action	C/D	W/R	D7	D6	D5	D4	D3	D2	D1	D0
Set LCD Mapping Control LC[3:0]	0	0	1	1	0	0	MY	MX	0	MSF

Set LC[3:0] for COM (row) mirror (MY), SEG (column) mirror (MX) and MSB first or LSB first options (MSF).

MY is implemented by reversing the mapping order between RAM and COM (row) electrodes. The data stored in RAM is not affected by MY command. MY will have immediate effect on the display image.

MX is implemented by selecting the CA or 239-CA as write/read (from host interface) display RAM column address so this function will only take effect after rewriting the RAM data.

MSF is implemented by MSB-LSB swapping. When MSB first (LC[0]) bit is set, data D[7:0] will be re-aligned as D[0:7] then be stored to RAM.

(17) System Reset

Action	C/D	W/R	D7	D6	D5	D4	D3	D2	D1	D0
System Reset	0	0	1	1	1	0	0	0	1	0

This command will activate the system reset. The system will take about 15ms to reset

(18) NOP

Action	C/D	W/R	D7	D6	D5	D4	D3	D2	D1	D0
No operation	0	0	1	1	1	0	0	0	1	1

This command is used for "no operation".

(19) Set LCD Bias Ratio

Action	C/D	W/R	D7	D6	D5	D4	D3	D2	D1	D0
Set Bias Ratio BR [1:0]	0	0	1	1	1	0	1	0	BR1	BR0

Bias ratio definition:

00b= 10.7 01b=11.3 **10b=12.0** 11b=12.7

(20) Reset Cursor Mode

Action	C/D	W/R	D7	D6	D5	D4	D3	D2	D1	D0
Return to Cursor. AC[3]=0, CA=CR	0	0	1	1	1	0	1	1	1	0

This command is used to reset cursor update mode function. See description below.

(21) Set Cursor Mode

Action	C/D	W/R	D7	D6	D5	D4	D3	D2	D1	D0
Set AC[3]=1 CR=CA	0	0	1	1	1	0	1	1	1	1

Set Cursor Mode command is used to turn on cursor update mode function. AC[3] will be set to 1, register CR will be set to the value of register CA

When AC[3]=1, column address (CA) will only increment with write RAM operation but not on read RAM operation. The address CA wraps around will also be suspended no matter what WA setting is. The purpose of this combination of features is to support "Read-Modify-Write" for cursor implementation.

Reset Cursor Mode command will clear cursor update mode flag (AC[3]=0), CA will be restored to previous CA value which is stored in CR, and CA, PA increment will return to its normal condition.

(22) Set Test Control

Action	C/D	W/R	D7	D6	D5	D4	D3	D2	D1	D0
Set TT	0	0	1	1	1	0	0	1	TT	
(Double byte command)	0	0	Testing parameter							

This command is used for UltraChip production testing. For UltraChip Only. Please do not use.

LCD VOLTAGE SETTING

MULTIPLEX RATES

Multiplex Rates (*MR*) is software programmable. Two MR is supported: 96, 128.

BIAS RATIO SELECTION

Bias Ratio (*BR*) is defined as the ratio between V_{LCD} and V_{BIAS} , i.e.

$$BR = V_{LCD} / V_{BIAS},$$

where $V_{BIAS} = V_{B1+} - V_{B1-} = V_{B0+} - V_{B0-}$.

The theoretical optimum *Bias Ratio* can be estimated by $\sqrt{MUX} + 1$. In some applications, *BR* is set to be 10~15% lower than the optimum value calculated above in order to lower V_{LCD} by 5~6%. Such setting generally will not cause visible change in image quality.

UC1608 supports four *BR* as listed below. *BR* can be selected by software program.

BR	0	1	2	3
Bias Ratio	10.7	11.3	12	12.7

Table 1: Bias Ratios

TEMPERATURE COMPENSATION

Four (4) different temperature compensation coefficients can be selected via software. The four coefficients are given below:

TC	0	1	2	3
% per °C	0.0	-0.05	-0.10	-0.20

Table 2: Temperature Compensation

V_{LCD} GENERATION

V_{LCD} may be supplied either by internal charge pump or by external power supply. The source of V_{LCD} is controlled by PC[2]. For good product performance it is recommended to keep V_{LCD} under 15.5V at room temperature.

When V_{LCD} is generated internally, the voltage level of V_{LCD} is determined by four control registers: *BR* (Bias Ratio), *GN* (Gain), *PM* (Potentiometer), and *TC* (Temperature Compensation), with the following relationship:

$$V_{LCD} = (C_{V0} + C_{PM} \times PM) \times (1 + (T - 25) \times C_T \%)$$

where

C_{V0} and C_{PM} are two constants, whose value depends on the *BR-GN* register setting. The values are provided in the table on next page,

PM is the numerical value of *PM* register,

T is the ambient temperature in °C, and

C_T is the temperature compensation coefficient as selected by *TC* register.

ITO LAYOUT FOR COG MODULES

When designing COG LCM, use lower resistance ITO glass for the SEG substrate to minimize SEG waveform crosstalk and minimize V_{DD} , V_{SS} ITO trace resistance. In addition, COM trace resistance and the SEG-COM crossover resistance should also be minimize.

The power supply circuit of UC1608 is designed to handle LCD panels with loading up to ~50nF using 10- /Sq ITO glass with $V_{D2/3} \geq 2.7V$. For larger LCD panels use lower resistance ITO glass or COF packaging.

Due to crosstalk consideration, ~50nF is also the recommended maximum LCD panel size for COG applications, unless 7- /Sq or lower resistance ITO glass is used for the SEG substrate.

V_{LCD} QUICK REFERENCE

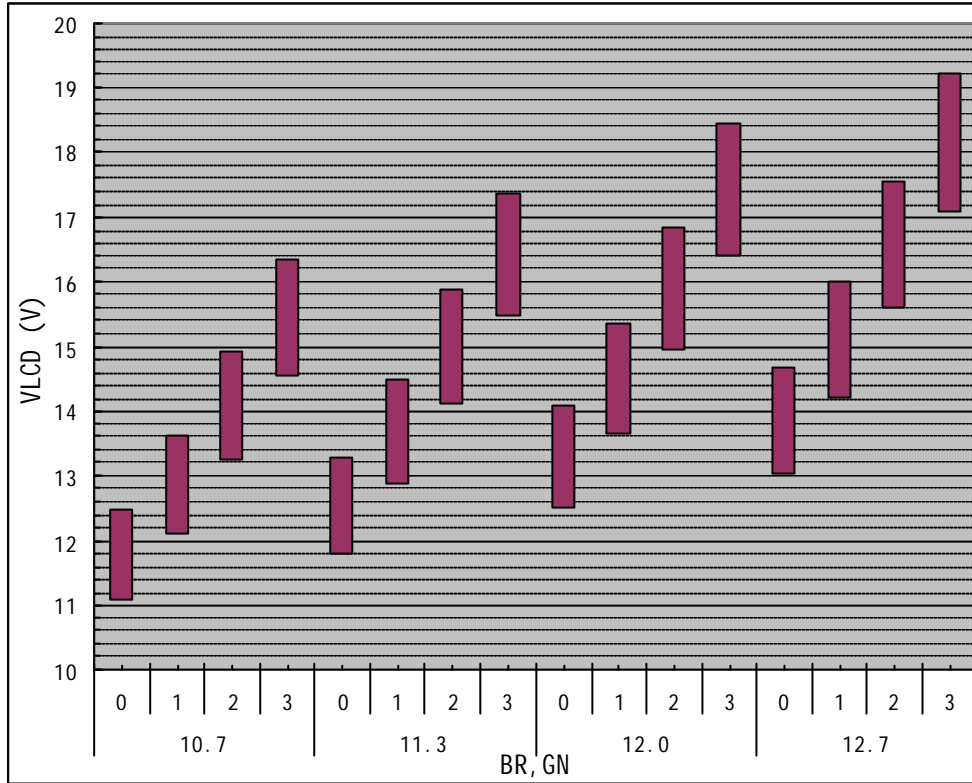

BR	GN	C _{V0} (V)	C _{PM} (mV)	VLCD Range (V)	
				PM=00H	PM=3FH
10.7	0	11.09	22.12	11.09	12.48
	1	12.10	24.19	12.10	13.63
	2	13.27	26.51	13.27	14.94
	3	14.55	28.44	14.55	16.34
11.3	0	11.79	23.56	11.79	13.28
	1	12.87	25.66	12.87	14.49
	2	14.12	28.01	14.12	15.88
	3	15.46	30.37	15.46	17.38
12	0	12.51	24.91	12.51	14.08
	1	13.65	27.05	13.65	15.36
	2	14.96	29.77	14.96	16.84
	3	16.40	32.34	16.40	18.44
12.7	0	13.03	25.89	13.03	14.66
	1	14.22	28.17	14.22	15.99
	2	15.59	31.14	15.59	17.55
	3	17.09	33.64	17.09	19.21

Note: For best product reliability, keep V_{LCD} under 16V under all temperature.

Hi-V GENERATOR CIRCUIT

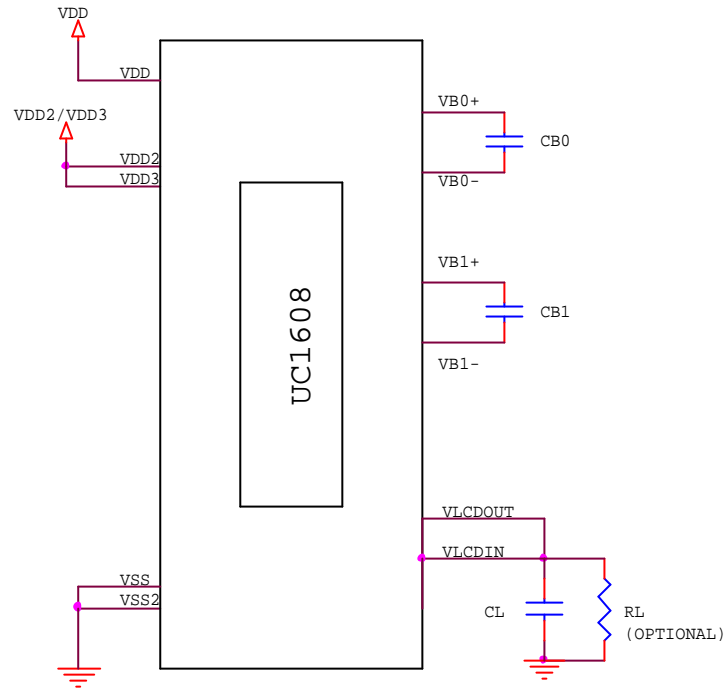

FIGURE 1: Reference circuit using internal Hi-V generator circuit

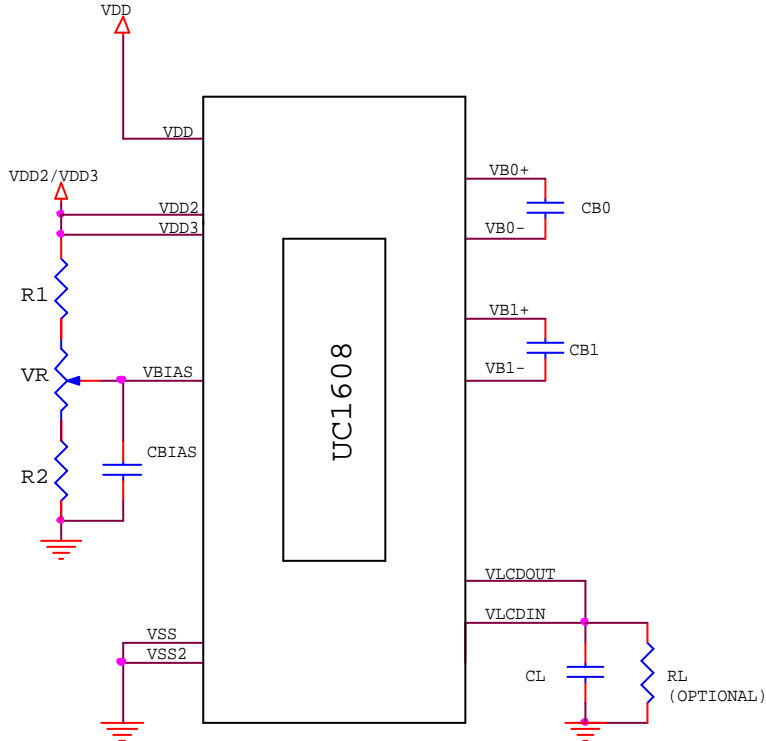

Figure 2: Reference circuit using external Bias source

Note :

- Recommended component values:
 - C_B : 150 ~250x LCD load capacitance or 4.7 μ F (2V), whichever is higher.
 - C_L : 50nF ~ 0.1 μ F (25V) is appropriate for most applications.
 - R_L : 10MO. Acts as a draining circuit when the power is abnormally shut down.
 - V_R : 1MO.
 - R_1, R_2 : See instructions below.
 - C_{BIAS} : 10nF ~ 0.1 μ F is recommended.
- The above component values are for reference only. Please optimize the values for the individual requirements of each specific application.
- To ensure consistency of LCM contrast, VLCD fine tuning is highly recommended.

Since the value of R_1/R_2 depends strongly on the GN, PM, BR settings, and vary slightly depends on the value of V_{DD2} , each LCM design will need to be optimized individually.

The following is the recommended procedures for selecting R_1 , R_2 and V_R values.

- Step 1: Adjust LCM for the best contrast with C_{BIAS} , but without R_1 , R_2 , V_R .
- Step 2: Measure V_{BIAS} voltage
- Step 3: Select V_R and R_2 (recommend to start with $V_R=1MO$, $R_2=200K$)
- Step 4: Calculate R_1 by: $R_1 = R_2 \times (V_{DD2}/V_{BIAS} - 1)$
- Step 5: Install R_1 , R_2 , V_R . The "neutral position" of V_R is at V_{BIAS}/V_{DD2} .
- Step 6: Test the fine tuning range by adjusting V_R over the full range.
- Step 7: If adjustment range is too narrow, reduce R_2 , ... and vice versa.
- Step 8: Repeat from Step 4.

- Step 2, Measure V_{BIAS} , is a very critical step. Since the purpose of this circuit is to maximize the contrast consistency of mass production units, please fine tuning GN, PM, BR across at least 150~200 LCM units (without the V_{LCD} adjustment circuit), before finalizing the values of PM, GN, BR. The average V_{BIAS} should be measured after PM, GN and BR is selected and finalized.
- Please note that, the "Neutral position" of the V_R (the position with minimum V_{LCD} adjustment) is not the center, but located at V_{BIAS}/V_{DD2} . Relative to this "Neutral position", the circuit produced by above procedure will have equal V_{LCD} adjustment range of +N% ~ -N% for the average V_{LCD} .
- Please avoid situations where the adjustment of the V_R can push UC1608 out of its safe V_{LCD} operation range (16V) at the low end of operating temperature range. If this happens, then it will be possible for the MP operators to damage the LCM by adjusting the V_R .
- Since the value of V_{DD2} can affect the adjustment of the V_R , please apply V_{DD2} that is intended to be used in the final application during the mass production V_{LCD} tuning process.
- Due to its minor sensitivity to the value of V_{DD2} , this V_{LCD} tuning circuit may not be suitable for "standard product" where the actual V_{DD2} value can vary far over 5% from the design V_{DD2} value. For such applications, please use a Zener diode, such as Hitachi HZU3LL, to replace V_{DD2} as the power source for this V_{LCD} fine tuning circuit.

LCD DISPLAY CONTROLS

CLOCK & TIMING GENERATOR

UC1608 contains a built-in system clock. All required components for the clock oscillator are built-in. No external parts are required.

DRIVER MODES

COM and SEG drivers can be in either Idle mode or Active mode, controlled by Display Enable flag (DC[2]). When COM drivers are in idle mode, their outputs are high-impedance (open circuit). When SEG drivers are in idle mode, their outputs are connected to V_{SS} .

DRIVER ARRANGEMENTS

The naming conventions are: COM(x), where $x=1\sim 128$, refers to the COM driver for the x-th row of pixels on the LCD panel.

The mapping of COM(x) to LCD pixel rows is the same for all MR, MX and MY settings. When MR is not 128, then COM(x) ~ COM128 ($X = MR+1$) should be left open circuit.

DISPLAY CONTROLS

There are three groups of display control flags in the control register DC: Driver Enable (DE), All-Pixel-ON (APO) and Inverse (PXV). DE has the overriding effect over PXV and APO.

DRIVER ENABLE (DE)

Driver Enable is controlled by the value of DC[2]. When DE is set to OFF (logic "0"), both SEG and COM drivers will become idle and UC1608 will put itself into Sleep mode to conserve power.

When DE is set to ON, UC1608 will first exit from Sleep mode, restore the power (V_{LCD} , V_{BIAS} etc.) and then turn on COM and SEG drivers.

ALL PIXELS ON (APO)

When set, this flag will force all active SEG drivers to output On signals, disregarding the data stored in the display buffer.

This flag has no effect when Display Enable is OFF and it has no effect on data stored in RAM.

INVERSE (PXV)

When this flag is set to ON, active SEG drivers will output the inverse of the value it received from the display buffer RAM (bit-wise inversion). This flag has no impact on data stored in RAM.

SCROLLING

SL register can be used to implement scroll function. Setting SL to a non-zero value N will result in the image being scrolled by N lines.

ITO LAYOUT CONSIDERATIONS

Since the COM scanning pulses of UC1608 can be as short as 98µS, it is critical to control the RC delay of COM and SEG signal to minimize crosstalk and maintain good mass production consistency.

For COG applications, low resistance ITO glass will help reduce SEG signal RC decay, minimize V_{DD} V_{SS} noise, and ensure sufficient V_{DD2} , V_{S2} supply for on-chip DC-DC converter.

Please ensure to keep V_{DD} and V_{SS} under 150 O.

ITO TRACES FOR COM SIGNALS

Excessive COM scanning pulse RC decay can cause fluctuation of contrast and increase of COM direction crosstalk.

Please limit the worst case of COM signals RC delay (RC_{MAX}) as calculated below

$$(R_{ROW} / 2.7 + R_{COM}) \times C_{ROW} < 5.5\mu S$$

where

- C_{ROW} : LCD loading capacitance of one row of pixels. It can be calculated by $C_{LCD}/Mux-Rate$, where C_{LCD} is the LCD panel capacitance.
- R_{ROW} : ITO resistance over one row of pixels within the active area
- R_{COM} : COM routing resistance from IC to the active area + COM driver output impedance.

(Use worst case values for all calculations)

In addition, please limit the min-max spread of RC decay to be:

$$|RC_{MAX} - RC_{MIN}| < 1.4\mu S$$

so that the COM distortions on the top of the screen to the bottom of the screen are uniform.

ITO TRACES FOR SEG SIGNALS

Excessive SEG signal RC decay can cause image dependent changes of medium gray shades and sharply increase of SEG direction crosstalk.

To minimize crosstalk, please limit the worst case of SEG signal RC delay as calculated below.

$$(R_{COL} / 2.7 + R_{SEG}) \times C_{COL} < 0.7\mu S$$

where

- C_{COL} : LCD loading capacitance of one pixel column. It can be calculated by $C_{LCD}/\#_column$, where C_{LCD} is the LCD panel capacitance.
- R_{COL} : ITO resistance over one column of pixels within the active area
- R_{SEG} : SEG routing resistance from IC to the active area + SEG driver output impedance.

(Use worst case values for all calculations)

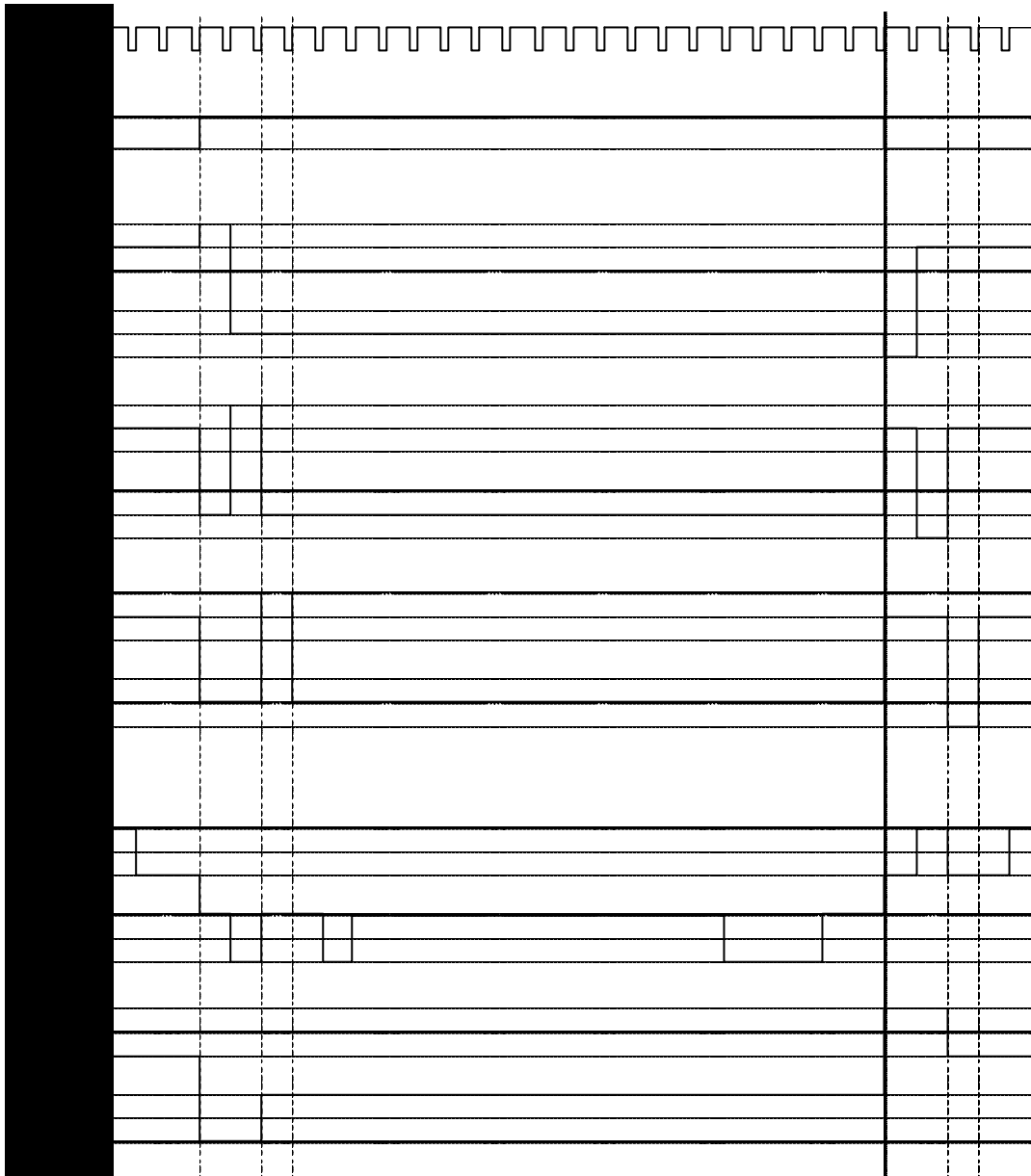

FIGURE 3 : COM and SEG Driving Waveform

HOST INTERFACE

As summarized in the table below, UC1608 supports two parallel bus protocols, in either 8-bit or 4-bit bus width, and three serial bus protocols.

Designers can either use parallel bus to achieve high data transfer rate, or use serial bus to create compact LCD modules.

Bus Type		8080		6800		S8 (4wr)	S8uc (3wr)	S9 (3wr)
Width		8-bit	4-bit	8-bit	4-bit	Serial		
Access		Read/Write				Write Only		
Control & Data Pins	BM[1:0]	10	00	11	01	00		01
	D[7:6]	Data	0X	Data	0X	10	11	10
	CS	Chip Select						
	CD	Control/Data						
	WR0	\overline{WR}		R/ \overline{W}		0		
	WR1	\overline{RD}		EN		0		
	D[5:4]	Data	–	Data	–	–		
	D[3:0]	Data	Data	Data	Data	D0=SCK, D3=SDA		

* Connect unused control pins and data bus pins to V_{DD} or V_{SS}

	CS Disable Interface	CS Init bus state	CD 1<=>0 Init bus state	CD 1=>0 init color mapping	RESET Init bus state	RESET init color mapping
8-bit	✓	–	–	✓	✓	✓
4-bit	✓	–	✓	✓	✓	✓
S8 or S9	✓	✓	–	✓	✓	✓
S8uc	✓	–	✓	✓	✓	✓

- CS disable bus interface – CS can be used to disable Bus Interface Write / Read Access.
- CD refers to CD transitions within valid CS window. CD = 0 means write command or read status.
- CS / CD Sync / RESET can be used to initialize bus state machine (like 4 bits / S8 / S9).
- RESET can be pin reset / soft reset / power on reset.
CD can be used to initialize the multi-byte input RGB format to/from on-chip SRAM mapping.

Table 3: Host interfaces Choices

PARALLEL INTERFACE

The timing relationship between UC1608 internal control signal RD, WR and their associated bus actions are shown in the figure below.

The Display RAM read interface is implemented as a two-stage pipe-line. This architecture requires that, every time memory address is modified, either in 8-bit mode or 4-bit mode, by either *Set CA*, or *Set PA* command, a dummy read cycle need to be performed before the actual data can propagate through the pipe-line and be read from data port D[7:0].

There is no pipeline in write interface of Display RAM. Data is transferred directly from bus buffer to internal RAM on the rising edges of write pulses.

8-BIT & 4-BIT BUS OPERATION

UC1608 supports both 8-bit and 4-bit bus width. The bus width is determined by pin BM[1].

4-bit bus operation exactly doubles the clock cycles of 8-bit bus operation, MSB followed by LSB, including the dummy read, which also requires two clock cycles. The bus cycle of 4-bit mode is reset each time Chip-Select or CD pin changes state.

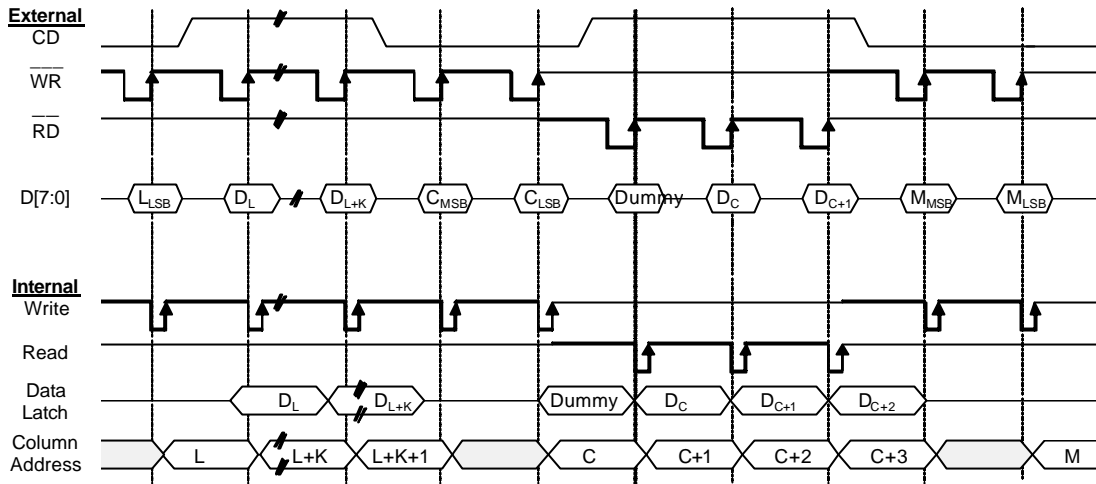

FIGURE 4: 8 bit Parallel Interface & Related Internal Signals

SERIAL INTERFACE

UC1608 supports three serial modes, one 4-wire SPI mode (S8), one compact 3/4-wire mode (S8uc) and one 3-wire SPI mode (S9). Bus interface mode is determined by the wiring of the BM[1:0] and D[7:6]. See table on last page for more detail.

of the data been transferred. During each write cycle, 8 bits of data, MSB first, are latched on eight rising SCK edges into an 8-bit data holder.

S8 (4-WIRE) INTERFACE

Only write operations are supported in 4-wire serial mode. Pin CS are used for chip select and bus cycle reset. Pin CD is used to determine the content

If CD=0, the data byte will be decoded as command. If CD=1, this 8-bit will be treated as data and transferred to proper address in the Display Data RAM on the rising edge of the last SCK pulse. Pin CD is examined when SCK is pulled low for the LSB (D0) of each token.

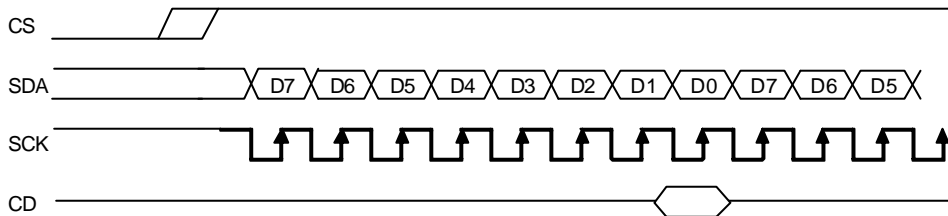

FIGURE 4.a: 4-wire Serial Interface (S8)

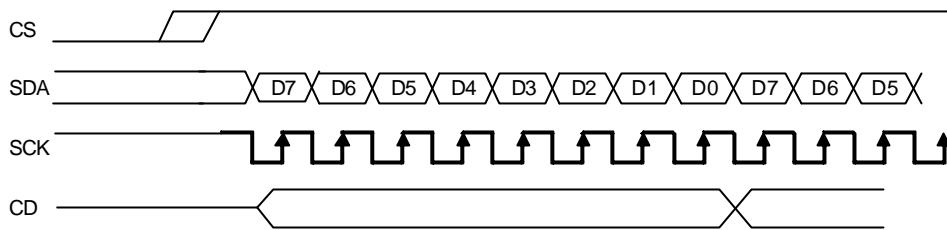

FIGURE 4.b: 3/4-wire Serial Interface (S8uc)

S8uc (3/4-WIRE) INTERFACE

Only write operations are supported in this 3/4-wire serial mode. The data format is identical as S8. However, in addition to CS pin, CD pin transitions will also reset the bus cycle in this mode. So, if CS pin are hardwired to enable chip-select, the bus can work properly with only three signal pins.

bits are latched on rising SCK edges into an 8-bit data holder. If CD=0, the data byte will be decoded as command. If CD=1, this 8-bit will be treated as data and transferred to proper address in the Display Data RAM at the rising edge of the last SCK pulse.

S9 (3-WIRE) INTERFACE

Only write operations are supported in this 3-wire serial mode. Pin CS are used for chip select and bus cycle reset. On each write cycle, the first bit is CD, which determines the content of the following 8 bits of data, MSB first. These 8 command or data

By sending CD information explicitly in the bit stream, control pin CD is not used, and should be connected to either V_{DD} or V_{SS} . The toggle of CS for each byte of data/command is recommended but optional.

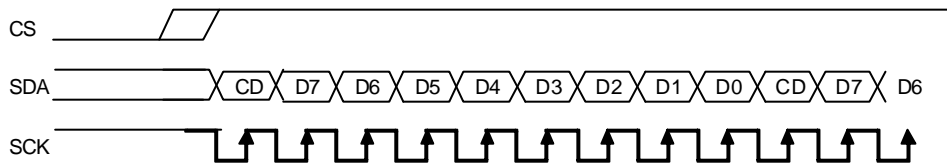

FIGURE 4.c: 3-wire Serial Interface (S9)

HOST INTERFACE REFERENCE CIRCUIT

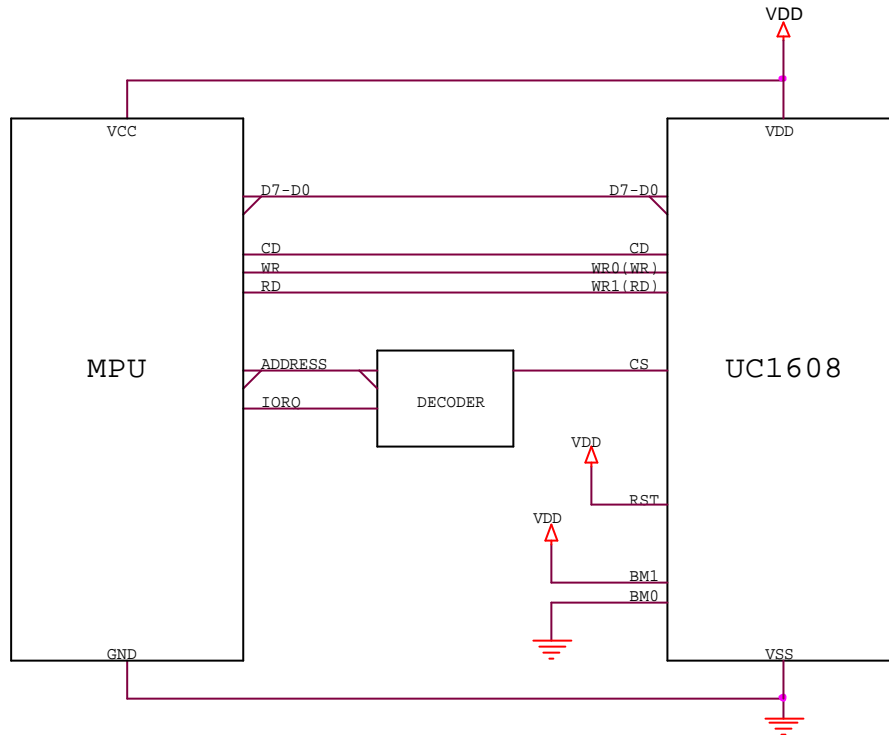

FIGURE 5: 8080/8bit parallel mode reference circuit

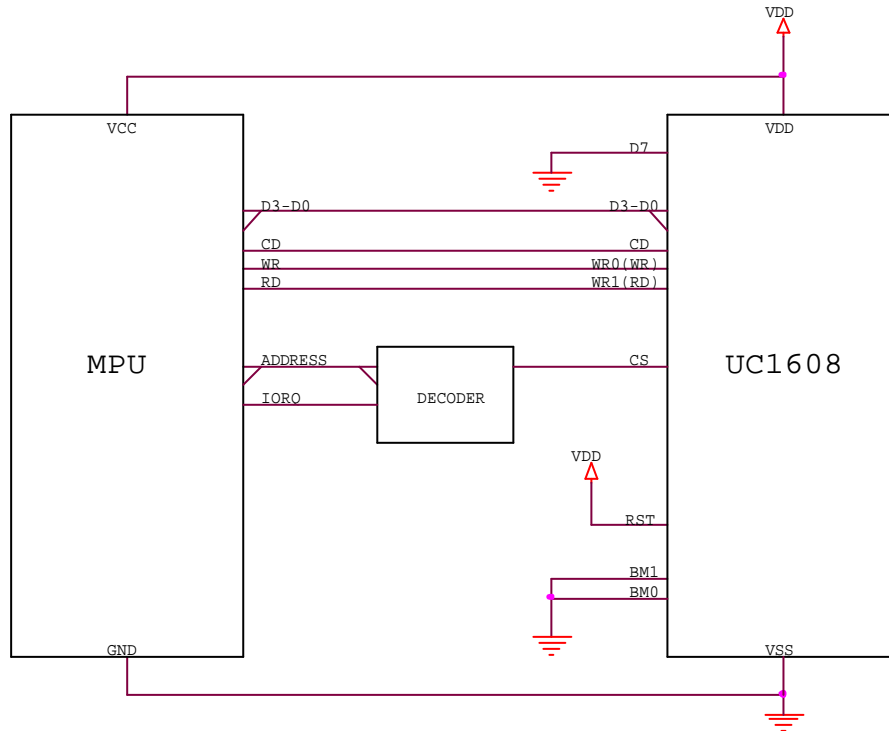

FIGURE 6: 8080/4bit parallel mode reference circuit

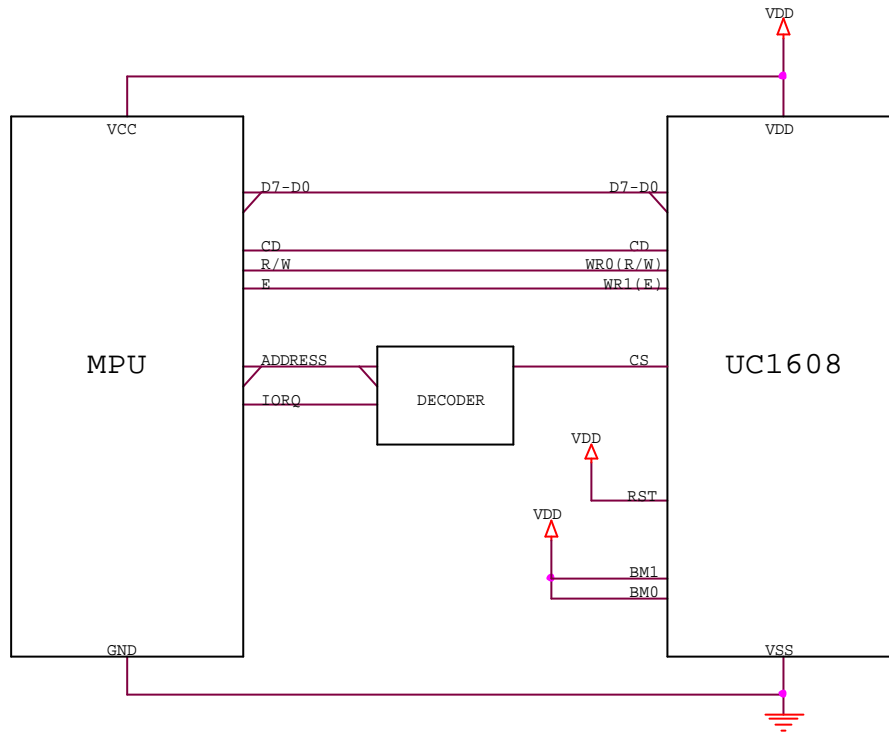

FIGURE 7 : 6800/8bit parallel mode reference circuit

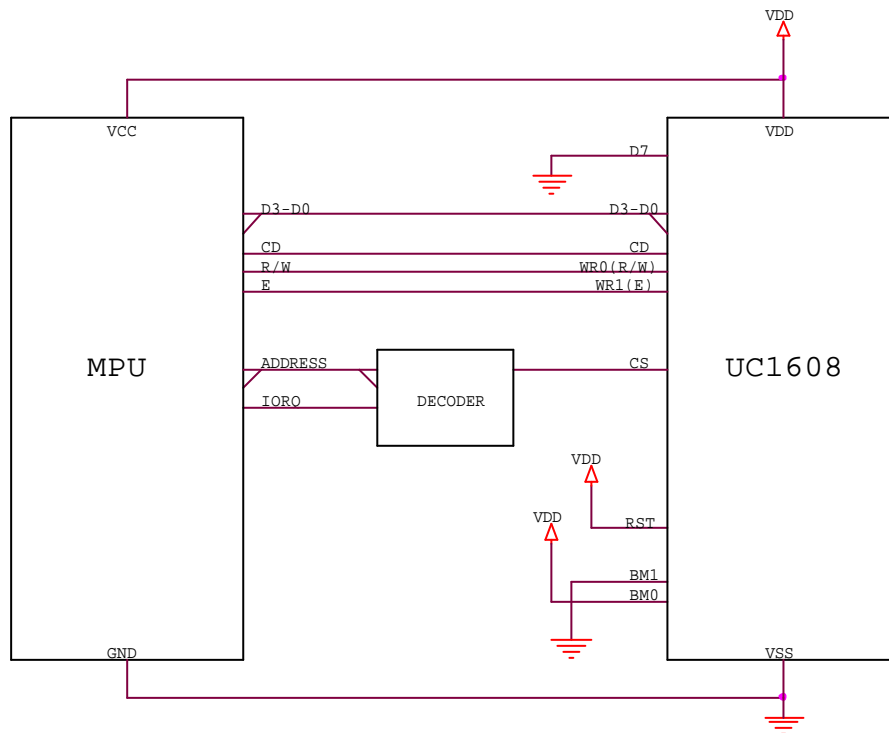

FIGURE 8 : 6800/4bit parallel mode reference circuit

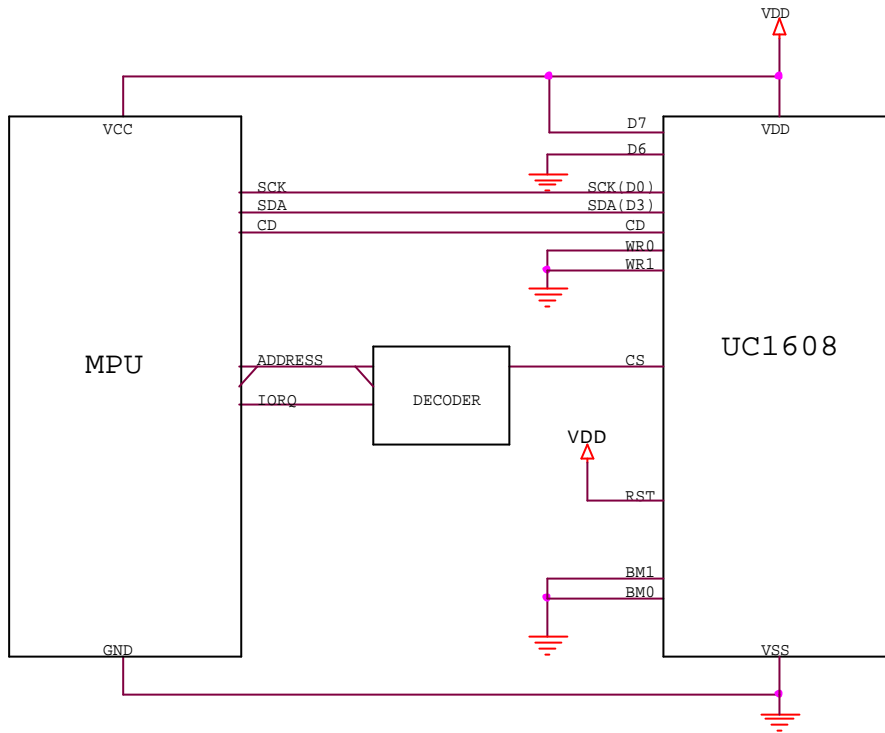

FIGURE 9: 4-Wires SPI (S8) serial mode reference circuit

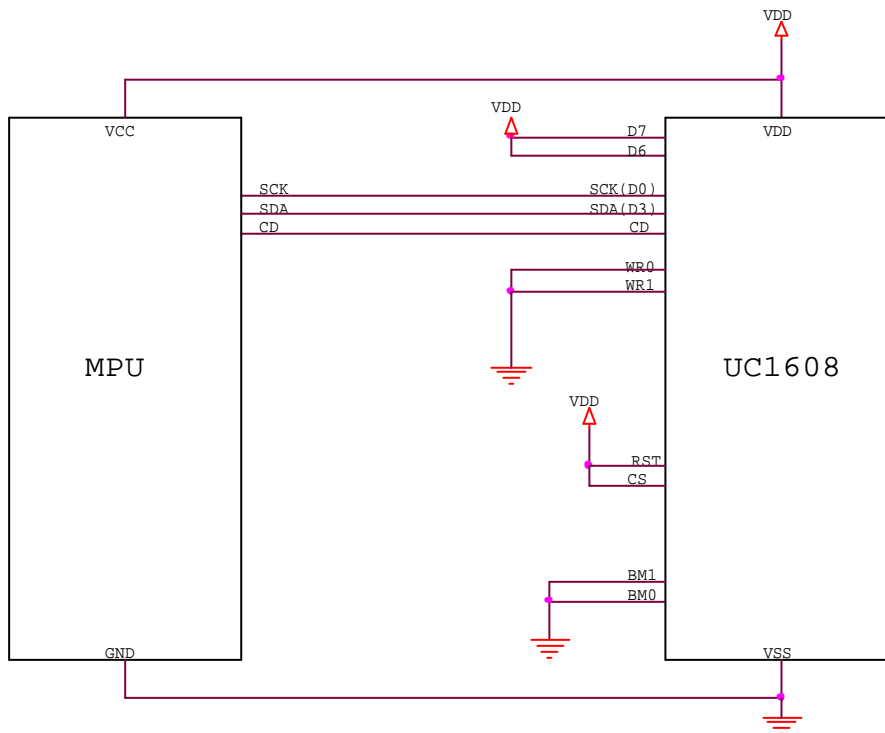

FIGURE 10: 3/4-Wires SPI (S8uc) serial mode reference circuit

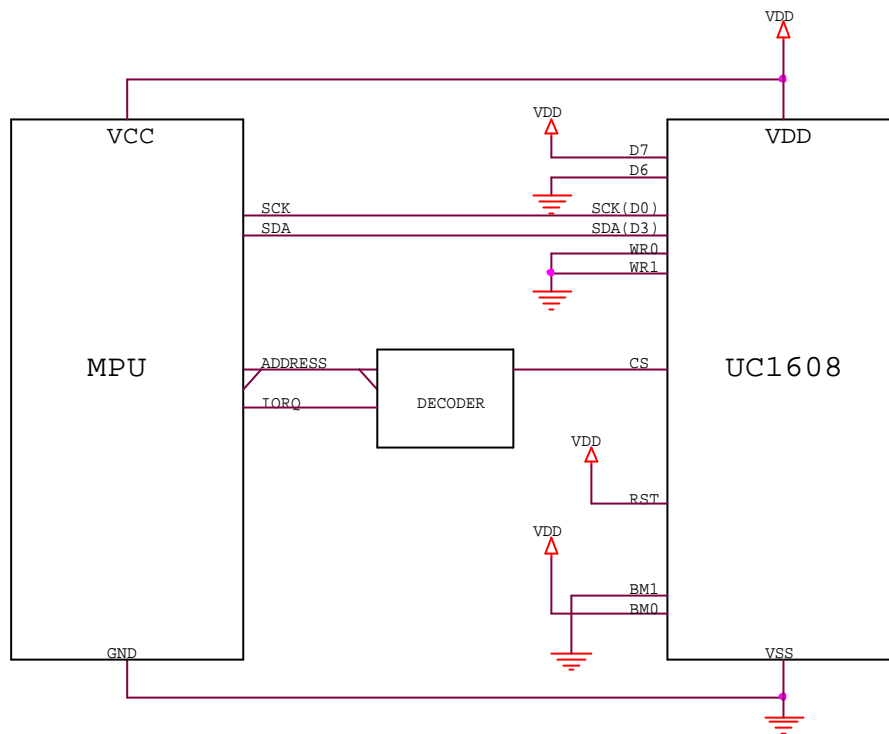

FIGURE 11 : 3-Wires SPI (S9) serial mode reference circuit

Note

- RST pin is optional. When RST pin is not used, connect the pin to V_{DD} .

DISPLAY DATA RAM

DATA ORGANIZATION

The display data is 1-bit per pixel and stored in a dual port static RAM (RAM, for Display Data RAM). The RAM size is 128x240 for UC1608. This array of data bits is further organized into pages of 8 bit slices to facilitate parallel bus interface.

When Mirror X (MX, LC[2]) is OFF, the 1st column of LCD pixels will correspond to the bits of the first byte of each page, the 2nd column of LCD pixels correspond to the bits of the second byte of each page, etc.

MSB FIRST OR LSB FIRST

There are two options to map D[7:0] to RAM, MSB first (MSF=1), or LSB first (MSF=0), as illustrated in next page.

DISPLAY DATA RAM ACCESS

The memory used in UC1608 Display Data RAM (RAM) is a special purpose dual port RAM which allows asynchronous access to both its column and row data. Thus, RAM can be independently accessed both for Host Interface and for display operations.

DISPLAY DATA RAM ADDRESSING

A Host Interface (HI) memory access operation starts with specifying Page Address (PA) and Column Address (CA) by issuing *Set Page Address* and *Set Column Address* commands.

If wrap-around (WA, AC[0]) is OFF (0), CA will stop increasing after reaching the end of page (239), and system programmers need to set the values of PA and CA explicitly.

If WA is ON (1), when CA reaches end of page, CA will be reset to 0 and PA will increment or decrement, depending on the setting of Page Increment Direction (PID, AC[2]). When PA reaches the boundary of RAM (i.e. PA = 0 or 19), PA will be wrapped around to the other end of RAM and continue.

MX IMPLEMENTATION

Column Mirroring (MX) is implemented by selecting either (CA) or (239–CA) as the RAM column address. Changing MX affects the data written to the RAM.

Since MX has no effect on data already stored in RAM, changing MX does not have immediate effect on the displayed pattern. To refresh the display, refresh the data stored in RAM after setting MX.

DISPLAY SCANNING

During each field of display, depending on the setting of MR, COM electrodes will be scanned in a fixed pattern at a rate of

$$(Frame\ Rate \times Mux\ Rate) \text{ rows/second.}$$

During each row period, the signal at the SEG drivers determines the ON/OFF status of the row of pixels being scanned.

ROW SCANNING

For each field, the scanning starts at COM1 through COMx, where x depends on the setting of MR.

COM electrode scanning (row scanning) orders are not affected by Start Line (SL) or Mirror Y (MY, LC[3]). When MY is 0, the effect of SL having a value *K* is to change the mapping of COM1 to the *K*-th bit slice of data stored in display RAM. Visually, SL having a non-zero value is equivalent to scrolling LCD display up by SL rows.

RAM ADDRESS GENERATION

The mapping of the data stored in the display SRAM and the scanning electrodes can be obtained by combining the fixed Row scanning sequence and the following RAM address generation formula.

During the display operation, the RAM line address generation can be mathematically represented as following:

For the 1st line period of each field

$$Line = SL$$

Otherwise

$$Line = \text{Mod}(Line+1, 128)$$

Where Mod is the modular operator, and *Line* is the bit slice line address of RAM to be outputted to SEG drivers. Line 0 corresponds to the first bit-slice of data in RAM.

The above *Line* generation formula produces the "loop around" effect as it effectively resets *Line* to 0 when *Line*+1 reaches 128.

Effects such as page scrolling can be emulated by changing SL dynamically.

MY IMPLEMENTATION

Row Mirroring (MY) is implemented by reversing the mapping order between COM electrodes and RAM, i.e. the mathematical address generation formula becomes:

For the 1st line period of each field

$$Line = \text{Mod}(SL + MUX - 1, 128)$$

where MUX = 96 or 128.

Otherwise

$$Line = \text{Mod}(Line - 1, 128)$$

Visually, the effect of MY is equivalent to flipping the display upside down. The data stored in display RAM is not affected by MY.

RESET & POWER MANAGEMENT

TYPES OF RESET

UC1608 has two different types of Reset:
Power-ON-Reset and *System-Reset*

Power-ON-Reset is performed right after V_{DD} is connected to power. *Power-On-Reset* will first wait for about 15mS, depending on the time required for V_{DD} to stabilize, and then trigger the *System Reset*

System Reset can also be activated by software command or by connecting RST pin to ground. In the following discussions, Reset means *System Reset*.

RESET STATUS

When UC1608 enters RESET sequence:

- Operation mode will be "Reset".
- System Status bits, RS and BZ, will stay 1 until the Reset process is completed *and* a "Display Enable" command is issued. (Issuing a Display Enable command after the Reset process is completed will change status from 1 to 0.

When BZ=1, the IC will only respond to *Read Status* command; all other commands are ignored.

- All control registers are reset to default values. Refer to Control Registers for details of their default values.

OPERATION MODES

UC1608 has three operating modes (OM):
Reset, Normal, Sleep.

For each mode, the related statuses are as below:

Mode	Reset	Sleep	Normal
OM	00	10	11
Host Interface	Active	Active	Active
Clock	OFF	OFF	ON
LCD Drivers	OFF	OFF	ON
Charge Pump	OFF	OFF	ON
Draining Circuit	ON	ON	OFF

Table 4: Operating Modes

CHANGING OPERATION MODE

In addition to *Power-ON-Reset*, two commands will initiate OM transitions:

Set Display Enable, and *System Reset*.

When DC[2] is modified by *Set Display Enable*, OM will be updated automatically. There is no other action required to enter Sleep mode.

Action	Mode	OM
Set Driver Enable to "0"	Sleep	10
Set Driver Enable to "1"	Normal	11
Reset command or RST pin pulled "L" Power ON reset	Reset	00

Table 5: OM changes

Both Reset mode and Sleep mode drain the charges stored in the external capacitors C_{B0} , C_{B1} , and C_L . When entering Reset mode or Sleep mode, the display drivers will be disabled.

The difference between Sleep mode and Reset mode is that, Reset mode clears all control registers and restores them to default values, while Sleep mode retains all the control registers values set by the user.

It is recommended to use Sleep Mode for Display OFF operations as UC1601 consumes very little energy in Sleep mode (typically under 2 μ A).

EXITING SLEEP MODE

UC1608 contains internal logic to check whether V_{LCD} and V_{BIAS} are ready before releasing COM and SEG drivers from their idle states. When exiting Sleep or Reset Mode, COM and SEG drivers will not be activated until UC1608 internal voltage sources are restored to their proper values.

POWER-UP SEQUENCE

UC1608 power-up sequence is simplified by built-in "Power Ready" flags and the automatic invocation of *System-Reset* command after *Power-ON-Reset*.

System programmers are only required to wait 15mS before the CPU starting to issue commands to UC1608. No additional time sequences are required between enabling the charge pump, turning on the display drivers, writing to RAM or any other commands.

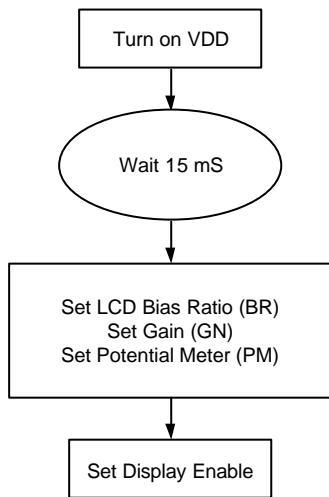

FIGURE 12: Reference Power-Up Sequence

POWER-DOWN SEQUENCE

To prevent the charge stored in capacitors C_{BX+} , C_{BX-} , and C_L from damaging the LCD when V_{DD} is switched off, use Reset mode to enable the built-in draining circuit and discharge these capacitors.

The draining resistor is 1K Ω for both V_{LCD} and V_{B+} . It is recommended to wait $3 \times RC$ for V_{LCD} and $1.5 \times RC$ for V_{B+} . For example, if C_L is 10nF, then the draining time required for V_{LCD} is 1~2mS.

When internal V_{LCD} is not used, UC1608 will NOT drain V_{LCD} during RESET. System designers need to make sure external V_{LCD} source is properly drained off before turning off V_{DD} .

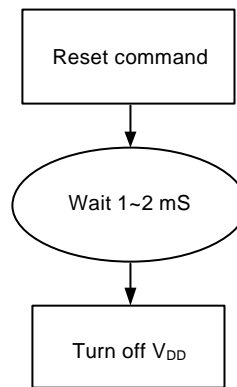

FIGURE 13: Reference Power-Down Sequence

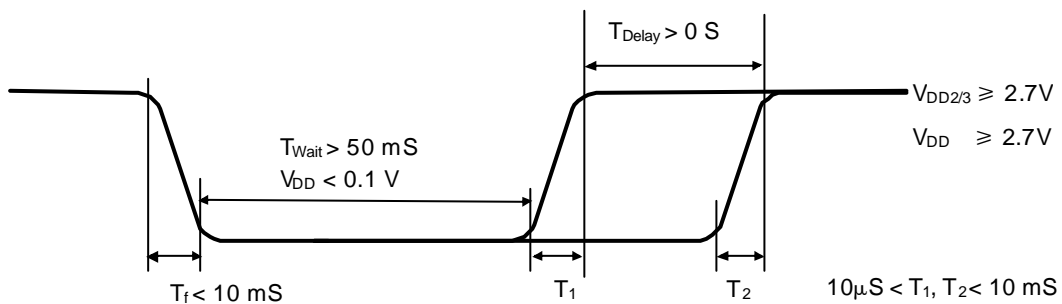

Figure 14: Delay allowance between V_{DD} and $V_{DD2/3}$

SAMPLE POWER COMMAND SEQUENCES

The following tables are examples of command sequence for power-up, power-down and display ON/OFF operations. These are only to demonstrate some “*typical, generic*” scenarios. Designers are encouraged to study related sections of the datasheet and find out what the best parameters and control sequences are for their specific design needs.

C/D The type of the interface cycle. It can be either Command (0) or Data (1)

W/R The direction of data flow of the cycle. It can be either Write (0) or Read (1).

Type Required: These items are required

Customized: These item are not necessary if customer parameters are the same as default

Advanced: We recommend new users to skip these commands and use default values.

Optional: These commands depend on what users want to do.

POWER-UP

Type	C/D	W/R	D7	D6	D5	D4	D3	D2	D1	D0	Chip action	Comments
R	–	–	–	–	–	–	–	–	–	–	Automatic Power-ON-Reset.	Wait 15mS after V_{DD} is ON
C	0	0	0	0	1	0	0	#	#	#	(5) Set MR and TC	
C	0	0	1	1	0	0	#	#	#	#	(15) Set LCD Mapping	Set up LCD specific parameters such as format, MX, MY, MSF, etc.
C	0	0	1	1	1	0	1	0	#	#	(18) Set Bias Ratio	
R	0	0	1	0	0	0	0	0	0	1	(9) Set Gain & PM	
C	1	0	#	#	#	#	#	#	#	#	Write display RAM	Set up display image
		
		
	1	0	#	#	#	#	#	#	#	#		
R	0	0	1	0	1	0	1	1	1	1	(13) Set Display Enable	

POWER-DOWN

Type	C/D	W/R	D7	D6	D5	D4	D3	D2	D1	D0	Chip action	Comments
R	0	0	1	1	1	0	0	0	1	0	(16) System Reset	
R	–	–	–	–	–	–	–	–	–	–	Draining capacitor	Wait 1~2m S before V_{DD} OFF

DISPLAY-OFF

Type	C/D	W/R	D7	D6	D5	D4	D3	D2	D1	D0	Chip action	Comments
R	0	0	1	0	1	0	1	1	1	0	(13) Set Display Disable	
C	1	0	#	#	#	#	#	#	#	#	Write display RAM	Set up display image (Image update is optional. Data in the RAM is retained through the SLEEP state.)
		
	1	0	#	#	#	#	#	#	#	#		
R	0	0	1	0	1	0	1	1	1	1	(13) Set Display Enable	

* This is only recommended for very brief display OFF (under 10mS).

If image becomes unstable use the *Extended Display OFF* approach shown below.

ABSOLUTE MAXIMUM RATINGS

In accordance with IEC134, note 1,2 and 3.

Symbol	Parameter	Min.	Max.	Unit
V_{DD}	Logic Supply voltage	-0.3	+4.0	V
V_{DD2}	LCD Generator Supply voltage	-0.3	+4.0	V
V_{DD3}	Analog Circuit Supply voltage	-0.3	+4.0	V
$V_{DD2/3} - V_{DD}$	Voltage difference between V_{DD} and $V_{DD2/3}$	--	1.6	V
V_{LCD}	LCD Generated voltage (-30°C ~ +80°C)	-0.3	+17.0	V
V_{IN}	Any input voltage	-0.4	$V_{DD} + 0.5$	V
T_{OPR}	Operating temperature range	-30	+85	°C
T_{STR}	Storage temperature	-55	+125	°C

Note:

1. V_{DD} based on $V_{SS} = 0V$
2. Stress values listed above may cause permanent damages to the device.

SPECIFICATIONS
DC CHARACTERISTICS

Symbol	Parameter	Conditions	Min.	Typ.	Max.	Unit
V_{DD}	Supply for digital circuit		2.7	2.8	3.3	V
$V_{DD2/3}$	Supply for bias & pump		2.7	2.8	3.3	V
V_{LCD}	Charge pump output	$V_{DD2/3} \geq 2.7V, 25^{\circ}C$		12.5	16	V
V_D	LCD data voltage	$V_{DD2/3} \geq 2.7V, 25^{\circ}C$			1.53	V
V_{IL}	Input logic LOW				$0.2V_{DD}$	V
V_{IH}	Input logic HIGH		$0.8V_{DD}$			V
V_{OL}	Output logic LOW				$0.2V_{DD}$	V
V_{OH}	Output logic HIGH		$0.8V_{DD}$			V
I_{IL}	Input leakage current				1.5	μA
C_{IN}	Input capacitance			5	10	PF
C_{OUT}	Output capacitance			5	10	PF
$R_{O(SEG)}$	SEG output impedance	$V_{LCD} = 12.5V$		1.5	3	k Ω
$R_{O(COM)}$	COM output impedance	$V_{LCD} = 9$		1.5	3	k Ω
f_{LINE}	Average frame rate		69	75	--	Hz

POWER CONSUMPTION

$V_{DD} = 2.7V$, $V_{DD2/3} = 2.7V$, Bias Ratio (BR) = 10b, GN = 11b, PM = 000000b,
 Panel Loading (PL): 26~43nF, MR = 128, Bus mode = 6800, $C_L = 0.1\mu F$, $C_B = 4.7\mu F$.
 All outputs are open circuit.

Display Pattern	Conditions	Typ. (μA)	Max. (μA)
All-OFF	Bus = idle	580	870
2-pixel checker	Bus = idle	730	1095
--	Bus = idle (standby current)	--	5

AC CHARACTERISTICS

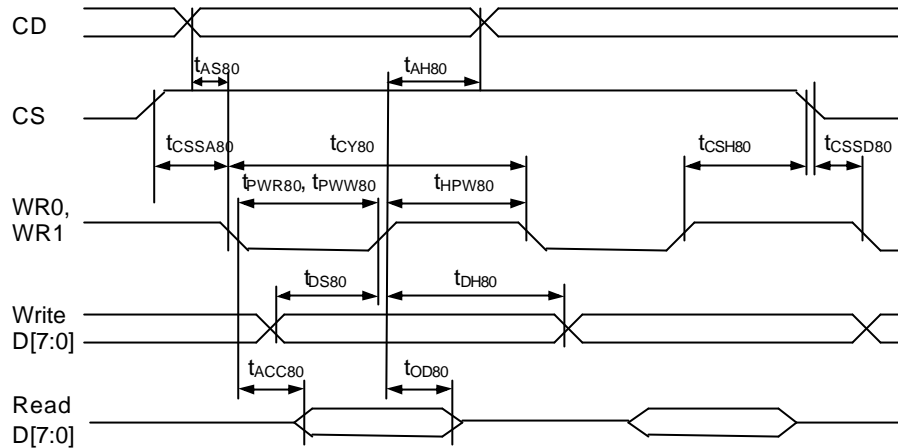

FIGURE 15: Parallel Bus Timing Characteristics (for 8080 MCU)

($2.7V \leq V_{DD} < 3.3V$, $T_a = -30$ to $+85^\circ C$)

Symbol	Signal	Description	Condition	Min.	Max.	Units
t_{AS80}	CD	Address setup time		0	-	nS
t_{AH80}		Address hold time		20	-	nS
t_{CY80}		System cycle time				nS
		8 bits bus (read)		140		
		(write)		140		
		4 bits bus (read)		140		
		(write)		140		
t_{PWR80}	WR1	Pulse width 8 bits (read)		65	-	nS
		4 bits		65		
t_{PWW80}	WR0	Pulse width 8 bits (write)		35	-	nS
		4 bits		35		
t_{HPW80}	WR0, WR1	High pulse width 8 bits bus (read)		65	-	nS
		(write)		35		
		4 bits bus (read)		65		
		(write)		35		
t_{DS80}	D0~D7	Data setup time		30	-	nS
t_{DH80}		Data hold time		20		
t_{ACC80}		Read access time	$C_L = 100pF$	-	60	nS
t_{OD80}		Output disable time		12	20	
t_{SSA80}	CS1/CS0	Chip select setup time		10		nS
t_{CSSD80}				10		
t_{CSH80}				20		

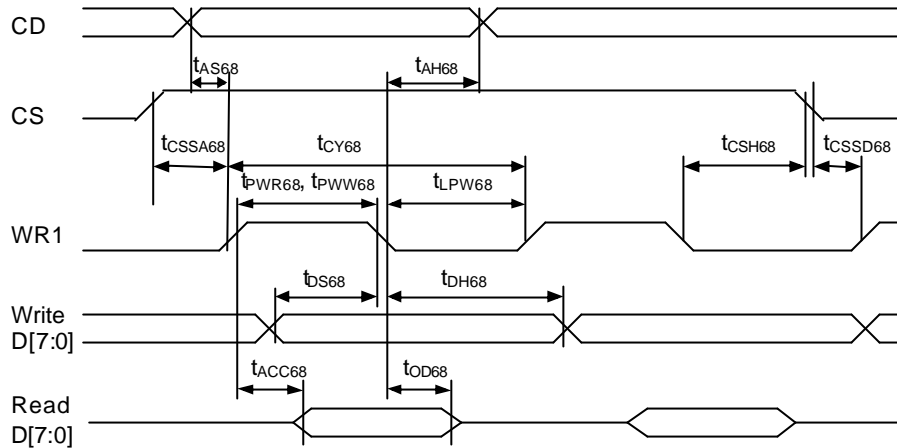

FIGURE 16: Parallel Bus Timing Characteristics (for 6800 MCU)

($2.7V \leq V_{DD} < 3.3V$, $T_a = -30$ to $+85^\circ C$)

Symbol	Signal	Description	Condition	Min.	Max.	Units
t_{AS68}	CD	Address setup time		0	–	nS
t_{AH68}		Address hold time		20	–	nS
T_{CY68}		System cycle time 8 bits bus (read) (write) 4 bits bus (read) (write)		140 140 140 140	–	nS
t_{PWR68}	WR1	Pulse width 8 bits (read) 4 bits		65 65	–	nS
t_{PWV68}		Pulse width 8 bits (write) 4 bits		35 35	–	nS
t_{LPW68}		Low pulse width 8 bits bus (read) (write) 4 bits bus (read) (write)		65 35 65 35	–	nS
t_{DS68}	D0~D7	Data setup time		30	–	nS
t_{DH68}		Data hold time		20	–	nS
t_{ACC68}		Read access time	$C_L = 100pF$	–	60	nS
t_{OD68}		Output disable time		12	20	nS
t_{CSSA68}	CS1/CS0	Chip select setup time		10		nS
t_{CSSD68}				10		nS
t_{CSH68}				20		nS

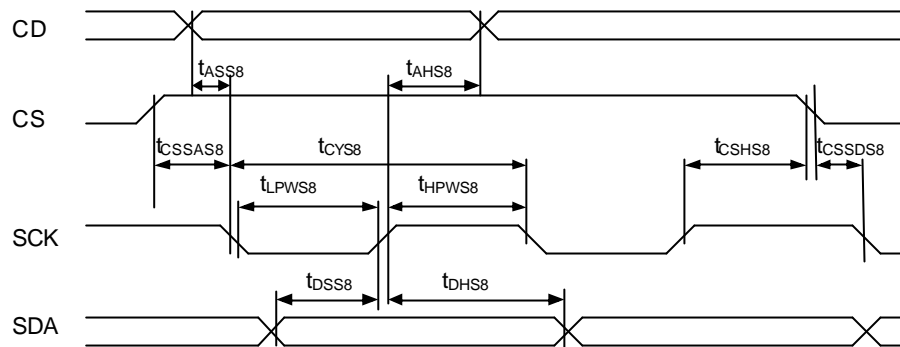

FIGURE 17: Serial Bus Timing Characteristics (for S8)

($2.7V \leq V_{DD} < 3.3V$, $T_a = -30$ to $+85^\circ C$)

Symbol	Signal	Description	Condition	Min.	Max.	Units
t_{ASS8}	CD	Address setup time		0	–	nS
t_{AHS8}		Address hold time		20	–	nS
t_{CYS8}	SCK	System cycle time		140	–	nS
t_{LPWS8}		Low pulse width		65	–	nS
t_{HPWS8}		High pulse width		65	–	nS
t_{DSS8}	SDA	Data setup time		30	–	nS
t_{DHS8}		Data hold time		20	–	nS
t_{CSSAS8}	CS	Chip select setup time		10		nS
t_{CSSDS8}				20		
t_{CSHS8}				10		

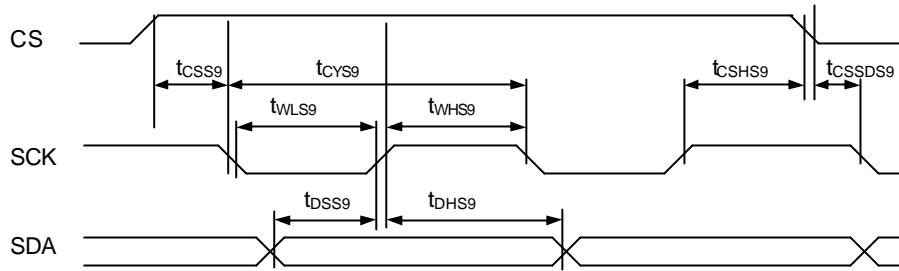

FIGURE 18: Serial Bus Timing Characteristics (for S9)

($2.7V \leq V_{DD} < 3.3V$, $T_a = -30$ to $+85^\circ C$)

Symbol	Signal	Description	Condition	Min.	Max.	Units
t_{CYS9}	SCK	System cycle time		140	–	nS
t_{LPWS9}		Low pulse width		65	–	nS
t_{HPWS9}		High pulse width		65	–	nS
t_{DSS9}	SDA	Data setup time		30	–	nS
t_{DHS9}		Data hold time		20		
t_{CSSAS9}	CS	Chip select setup time		10		nS
t_{CSSDS9}				20		
t_{CSHS9}				10		

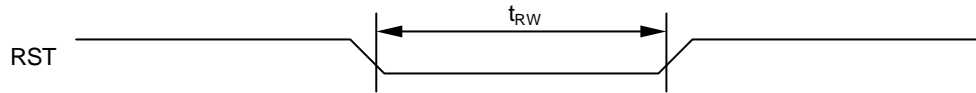

FIGURE 19: Reset Characteristics

($2.7V \leq V_{DD} < 3.3V$, $T_a = -30$ to $+85^\circ\text{C}$)

Symbol	Signal	Description	Condition	Min.	Max.	Units
t_{RW}	RST	Reset low pulse width		1000	–	nS

PHYSICAL DIMENSIONS

<p>DIE SIZE: 11480 x 1375 μM^2 (Typ.)</p> <p>DIE THICKNESS: 0.5 mm (Typ.)</p> <p>BUMP HEIGHT: 17 \pm 1 μM (within die)</p> <p>BUMP SIZE: 112 x 27 μM^2 (Typ.)</p> <p>BUMP PITCH: SEG: 45 μM (Typ.) COM: 45 μM (Typ.)</p> <p>BUMP GAP: 18 μM (Typ.)</p> <p>COORDINATE ORIGIN: Chip center</p> <p>PAD REFERENCE: Pad center</p> <p>(Drawing and coordinates are for the Circuit/Bump view.)</p>

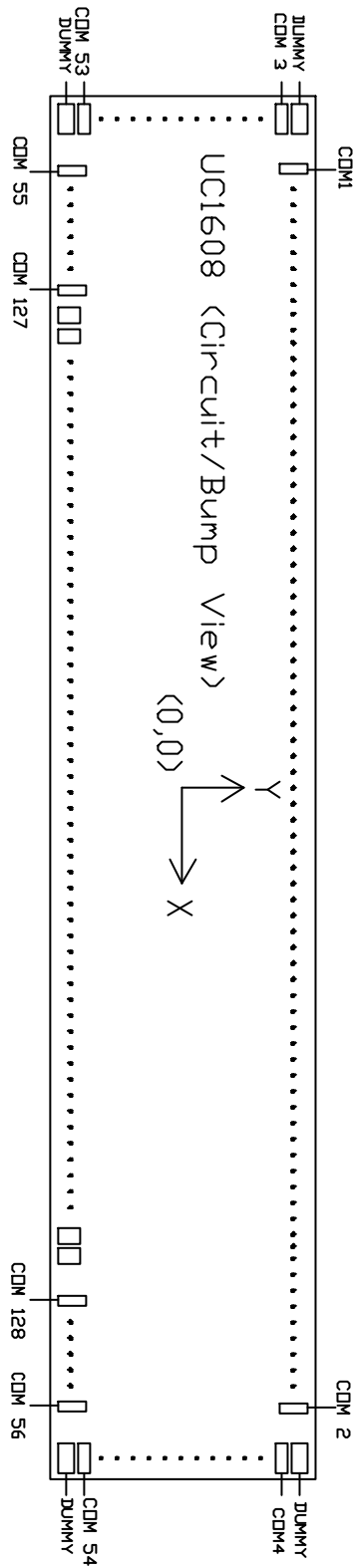

ALIGNMENT MARK INFORMATION

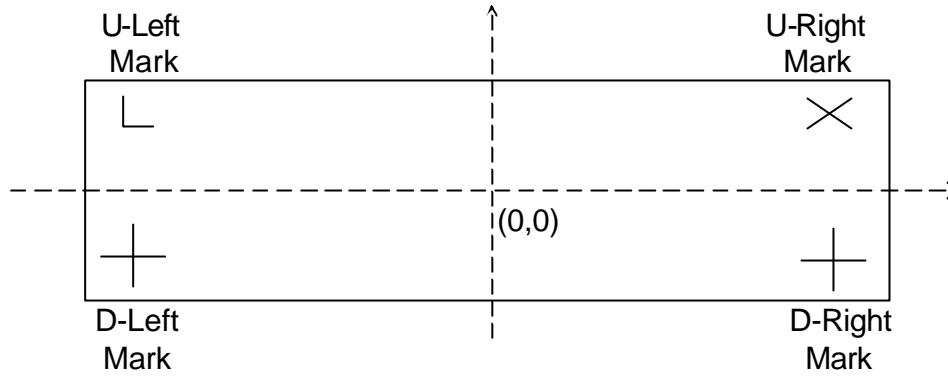

SHAPE OF THE ALIGNMENT MARK:

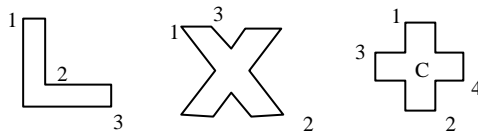

NOTE :

Alignment mark is on Metal3 under Passivation.

COORDINATES :

	U-Left Mark		U-Right Mark	
	X	Y	X	Y
1	-5533.5	637.1	5464.9	637.1
2	-5517.9	626.6	5530.0	611.0
3	-5488.5	611.1	5490.4	637.1

	D-Left Mark		D-Right Mark	
	X	Y	X	Y
1	-5516.5	-592.1	5502.0	-592.1
2	-5505.5	-637.1	5513.0	-637.1
3	-5533.5	-609.1	5485.0	-609.1
4	-5488.5	-620.1	5530.0	-620.1
C	-5511.0	-614.6	5507.5	-614.6

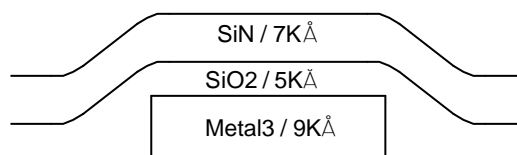

FOR NON-OTP PROCESS CROSS-SECTION

PAD COORDINATES

Pin	Name	X	Y	W	H
1	DUMMY	-5630.3	617.0	112.0	27.0
2	COM3	-5630.3	572.0	112.0	27.0
3	COM5	-5630.3	527.0	112.0	27.0
4	COM7	-5630.3	482.0	112.0	27.0
5	COM9	-5630.3	437.0	112.0	27.0
6	COM11	-5630.3	392.0	112.0	27.0
7	COM13	-5630.3	347.0	112.0	27.0
8	COM15	-5630.3	302.0	112.0	27.0
9	COM17	-5630.3	257.0	112.0	27.0
10	COM19	-5630.3	212.0	112.0	27.0
11	COM21	-5630.3	167.0	112.0	27.0
12	COM23	-5630.3	122.0	112.0	27.0
13	COM25	-5630.3	77.0	112.0	27.0
14	COM27	-5630.3	32.0	112.0	27.0
15	COM29	-5630.3	-13.0	112.0	27.0
16	COM31	-5630.3	-58.0	112.0	27.0
17	COM33	-5630.3	-103.0	112.0	27.0
18	COM35	-5630.3	-148.0	112.0	27.0
19	COM37	-5630.3	-193.0	112.0	27.0
20	COM39	-5630.3	-238.0	112.0	27.0
21	COM41	-5630.3	-283.0	112.0	27.0
22	COM43	-5630.3	-328.0	112.0	27.0
23	COM45	-5630.3	-373.0	112.0	27.0
24	COM47	-5630.3	-418.0	112.0	27.0
25	COM49	-5630.3	-463.0	112.0	27.0
26	COM51	-5630.3	-508.0	112.0	27.0
27	COM53	-5630.3	-553.0	112.0	27.0
28	DUMMY	-5630.3	-598.0	112.0	27.0
29	COM55	-5422.5	-577.6	27.0	112.0
30	COM57	-5377.5	-577.6	27.0	112.0
31	COM59	-5332.5	-577.6	27.0	112.0
32	COM61	-5287.5	-577.6	27.0	112.0
33	COM63	-5242.5	-577.6	27.0	112.0
34	COM65	-5197.5	-577.6	27.0	112.0
35	COM67	-5152.5	-577.6	27.0	112.0
36	COM69	-5107.5	-577.6	27.0	112.0
37	COM71	-5062.5	-577.6	27.0	112.0
38	COM73	-5017.5	-577.6	27.0	112.0
39	COM75	-4972.5	-577.6	27.0	112.0
40	COM77	-4927.5	-577.6	27.0	112.0
41	COM79	-4882.5	-577.6	27.0	112.0
42	COM81	-4837.5	-577.6	27.0	112.0
43	COM83	-4792.5	-577.6	27.0	112.0
44	COM85	-4747.5	-577.6	27.0	112.0
45	COM87	-4702.5	-577.6	27.0	112.0
46	COM89	-4657.5	-577.6	27.0	112.0
47	COM91	-4612.5	-577.6	27.0	112.0
48	COM93	-4567.5	-577.6	27.0	112.0
49	COM95	-4522.5	-577.6	27.0	112.0
50	COM97	-4477.5	-577.6	27.0	112.0
51	COM99	-4432.5	-577.6	27.0	112.0
52	COM101	-4387.5	-577.6	27.0	112.0
53	COM103	-4342.5	-577.6	27.0	112.0
54	COM105	-4297.5	-577.6	27.0	112.0
55	COM107	-4252.5	-577.6	27.0	112.0
56	COM109	-4207.5	-577.6	27.0	112.0
57	COM111	-4162.5	-577.6	27.0	112.0
58	COM113	-4117.5	-577.6	27.0	112.0
59	COM115	-4072.5	-577.6	27.0	112.0
60	COM117	-4027.5	-577.6	27.0	112.0
61	COM119	-3982.5	-577.6	27.0	112.0
62	COM121	-3937.5	-577.6	27.0	112.0
63	COM123	-3892.5	-577.6	27.0	112.0

Pin	Name	X	Y	W	H
64	COM125	-3847.5	-577.6	27.0	112.0
65	COM127	-3802.5	-577.6	27.0	112.0
66	BM1	-3728.6	-591.1	52.0	85.0
67	BMD	-3653.8	-591.1	52.0	85.0
68	VDDX	-3583.2	-591.1	52.0	85.0
69	CS	-3512.8	-591.1	52.0	85.0
70	RST	-3438.0	-591.1	52.0	85.0
71	CD	-3363.2	-591.1	52.0	85.0
72	WR0	-3288.4	-591.1	52.0	85.0
73	WR1	-3213.6	-591.1	52.0	85.0
74	D0	-3134.2	-591.1	52.0	85.0
75	D1	-3064.2	-591.1	52.0	85.0
76	D2	-2994.2	-591.1	52.0	85.0
77	D3	-2924.2	-591.1	52.0	85.0
78	D4	-2854.2	-591.1	52.0	85.0
79	D5	-2784.2	-591.1	52.0	85.0
80	D6	-2714.2	-591.1	52.0	85.0
81	D7	-2644.2	-591.1	52.0	85.0
82	VDD	-2573.3	-591.1	52.0	85.0
83	VDD	-2503.3	-591.1	52.0	85.0
84	VDD	-2433.3	-591.1	52.0	85.0
85	VDD	-2363.3	-591.1	52.0	85.0
86	VDD	-2293.3	-591.1	52.0	85.0
87	VDD2	-1782.5	-591.1	52.0	85.0
88	VDD2	-1712.3	-591.1	52.0	85.0
89	VDD2	-1642.3	-591.1	52.0	85.0
90	VDD2	-1572.3	-591.1	52.0	85.0
91	VDD2	-1502.3	-591.1	52.0	85.0
92	VDD3	-1228.4	-591.1	52.0	85.0
93	VDD3	-1158.2	-591.1	52.0	85.0
94	VDD3	-1088.2	-591.1	52.0	85.0
95	VSS2	-1018.2	-591.1	52.0	85.0
96	VSS2	-948.2	-591.1	52.0	85.0
97	VSS2	-878.2	-591.1	52.0	85.0
98	VSS2	-808.2	-591.1	52.0	85.0
99	VSS2	-738.2	-591.1	52.0	85.0
100	VSS	-556.2	-591.1	52.0	85.0
101	VSS	-486.2	-591.1	52.0	85.0
102	VSS	-416.2	-591.1	52.0	85.0
103	VSS	-346.2	-591.1	52.0	85.0
104	VBIAS	-276.2	-591.1	52.0	85.0
105	VLCDOUT	-87.2	-591.1	52.0	85.0
106	VLCDOUT	-17.2	-591.1	52.0	85.0
107	VLCDIN	331.8	-591.1	52.0	85.0
108	VLCDIN	402.1	-591.1	52.0	85.0
109	TP1	472.1	-591.1	52.0	85.0
110	TP2	732.5	-591.1	52.0	85.0
111	TP3	802.7	-591.1	52.0	85.0
112	VB0+	976.4	-591.1	52.0	85.0
113	VB0+	1046.4	-591.1	52.0	85.0
114	VB0+	1116.4	-591.1	52.0	85.0
115	VB0+	1186.4	-591.1	52.0	85.0
116	VB0-	1535.4	-591.1	52.0	85.0
117	VB0-	1605.7	-591.1	52.0	85.0
118	VB0-	1675.7	-591.1	52.0	85.0
119	VB0-	1745.7	-591.1	52.0	85.0
120	VB0-	1815.7	-591.1	52.0	85.0
121	VB0-	1885.7	-591.1	52.0	85.0
122	TST4	1956.3	-591.1	52.0	85.0
123	TST1	2127.3	-591.1	52.0	85.0
124	VB1+	2476.3	-591.1	52.0	85.0
125	VB1+	2546.6	-591.1	52.0	85.0
126	VB1+	2616.6	-591.1	52.0	85.0

Pin	Name	X	Y	W	H
127	VB1+	2686.6	-591.1	52.0	85.0
128	VB1+	2756.6	-591.1	52.0	85.0
129	VB1+	2826.6	-591.1	52.0	85.0
130	TST2	2896.6	-591.1	52.0	85.0
131	TST3	3177.7	-591.1	52.0	85.0
132	VB1-	3394.9	-591.1	52.0	85.0
133	VB1-	3465.1	-591.1	52.0	85.0
134	VB1-	3535.1	-591.1	52.0	85.0
135	VB1-	3605.1	-591.1	52.0	85.0
136	VB1-	3675.1	-591.1	52.0	85.0
137	VB1-	3745.1	-591.1	52.0	85.0
138	COM128	3802.5	-577.6	27.0	112.0
139	COM126	3847.5	-577.6	27.0	112.0
140	COM124	3892.5	-577.6	27.0	112.0
141	COM122	3937.5	-577.6	27.0	112.0
142	COM120	3982.5	-577.6	27.0	112.0
143	COM118	4027.5	-577.6	27.0	112.0
144	COM116	4072.5	-577.6	27.0	112.0
145	COM114	4117.5	-577.6	27.0	112.0
146	COM112	4162.5	-577.6	27.0	112.0
147	COM110	4207.5	-577.6	27.0	112.0
148	COM108	4252.5	-577.6	27.0	112.0
149	COM106	4297.5	-577.6	27.0	112.0
150	COM104	4342.5	-577.6	27.0	112.0
151	COM102	4387.5	-577.6	27.0	112.0
152	COM100	4432.5	-577.6	27.0	112.0
153	COM98	4477.5	-577.6	27.0	112.0
154	COM96	4522.5	-577.6	27.0	112.0
155	COM94	4567.5	-577.6	27.0	112.0
156	COM92	4612.5	-577.6	27.0	112.0
157	COM90	4657.5	-577.6	27.0	112.0
158	COM88	4702.5	-577.6	27.0	112.0
159	COM86	4747.5	-577.6	27.0	112.0
160	COM84	4792.5	-577.6	27.0	112.0
161	COM82	4837.5	-577.6	27.0	112.0
162	COM80	4882.5	-577.6	27.0	112.0
163	COM78	4927.5	-577.6	27.0	112.0
164	COM76	4972.5	-577.6	27.0	112.0
165	COM74	5017.5	-577.6	27.0	112.0
166	COM72	5062.5	-577.6	27.0	112.0
167	COM70	5107.5	-577.6	27.0	112.0
168	COM68	5152.5	-577.6	27.0	112.0
169	COM66	5197.5	-577.6	27.0	112.0
170	COM64	5242.5	-577.6	27.0	112.0
171	COM62	5287.5	-577.6	27.0	112.0
172	COM60	5332.5	-577.6	27.0	112.0
173	COM58	5377.5	-577.6	27.0	112.0
174	COM56	5422.5	-577.6	27.0	112.0
175	DUMMY	5630.3	-598.0	112.0	27.0
176	COM54	5630.3	-553.0	112.0	27.0
177	COM52	5630.3	-508.0	112.0	27.0
178	COM50	5630.3	-463.0	112.0	27.0
179	COM48	5630.3	-418.0	112.0	27.0
180	COM46	5630.3	-373.0	112.0	27.0
181	COM44	5630.3	-328.0	112.0	27.0
182	COM42	5630.3	-283.0	112.0	27.0
183	COM40	5630.3	-238.0	112.0	27.0
184	COM38	5630.3	-193.0	112.0	27.0
185	COM36	5630.3	-148.0	112.0	27.0
186	COM34	5630.3	-103.0	112.0	27.0
187	COM32	5630.3	-58.0	112.0	27.0
188	COM30	5630.3	-13.0	112.0	27.0
189	COM28	5630.3	32.0	112.0	27.0
190	COM26	5630.3	77.0	112.0	27.0
191	COM24	5630.3	122.0	112.0	27.0

Pin	Name	X	Y	W	H
192	COM22	5630.3	167.0	112.0	27.0
193	COM20	5630.3	212.0	112.0	27.0
194	COM18	5630.3	257.0	112.0	27.0
195	COM16	5630.3	302.0	112.0	27.0
196	COM14	5630.3	347.0	112.0	27.0
197	COM12	5630.3	392.0	112.0	27.0
198	COM10	5630.3	437.0	112.0	27.0
199	COM8	5630.3	482.0	112.0	27.0
200	COM6	5630.3	527.0	112.0	27.0
201	COM4	5630.3	572.0	112.0	27.0
202	DUMMY	5630.3	617.0	112.0	27.0
203	COM2	5422.5	577.6	27.0	112.0
204	SEG1	5377.5	577.6	27.0	112.0
205	SEG2	5332.5	577.6	27.0	112.0
206	SEG3	5287.5	577.6	27.0	112.0
207	SEG4	5242.5	577.6	27.0	112.0
208	SEG5	5197.5	577.6	27.0	112.0
209	SEG6	5152.5	577.6	27.0	112.0
210	SEG7	5107.5	577.6	27.0	112.0
211	SEG8	5062.5	577.6	27.0	112.0
212	SEG9	5017.5	577.6	27.0	112.0
213	SEG10	4972.5	577.6	27.0	112.0
214	SEG11	4927.5	577.6	27.0	112.0
215	SEG12	4882.5	577.6	27.0	112.0
216	SEG13	4837.5	577.6	27.0	112.0
217	SEG14	4792.5	577.6	27.0	112.0
218	SEG15	4747.5	577.6	27.0	112.0
219	SEG16	4702.5	577.6	27.0	112.0
220	SEG17	4657.5	577.6	27.0	112.0
221	SEG18	4612.5	577.6	27.0	112.0
222	SEG19	4567.5	577.6	27.0	112.0
223	SEG20	4522.5	577.6	27.0	112.0
224	SEG21	4477.5	577.6	27.0	112.0
225	SEG22	4432.5	577.6	27.0	112.0
226	SEG23	4387.5	577.6	27.0	112.0
227	SEG24	4342.5	577.6	27.0	112.0
228	SEG25	4297.5	577.6	27.0	112.0
229	SEG26	4252.5	577.6	27.0	112.0
230	SEG27	4207.5	577.6	27.0	112.0
231	SEG28	4162.5	577.6	27.0	112.0
232	SEG29	4117.5	577.6	27.0	112.0
233	SEG30	4072.5	577.6	27.0	112.0
234	SEG31	4027.5	577.6	27.0	112.0
235	SEG32	3982.5	577.6	27.0	112.0
236	SEG33	3937.5	577.6	27.0	112.0
237	SEG34	3892.5	577.6	27.0	112.0
238	SEG35	3847.5	577.6	27.0	112.0
239	SEG36	3802.5	577.6	27.0	112.0
240	SEG37	3757.5	577.6	27.0	112.0
241	SEG38	3712.5	577.6	27.0	112.0
242	SEG39	3667.5	577.6	27.0	112.0
243	SEG40	3622.5	577.6	27.0	112.0
244	SEG41	3577.5	577.6	27.0	112.0
245	SEG42	3532.5	577.6	27.0	112.0
246	SEG43	3487.5	577.6	27.0	112.0
247	SEG44	3442.5	577.6	27.0	112.0
248	SEG45	3397.5	577.6	27.0	112.0
249	SEG46	3352.5	577.6	27.0	112.0
250	SEG47	3307.5	577.6	27.0	112.0
251	SEG48	3262.5	577.6	27.0	112.0
252	SEG49	3217.5	577.6	27.0	112.0
253	SEG50	3172.5	577.6	27.0	112.0
254	SEG51	3127.5	577.6	27.0	112.0
255	SEG52	3082.5	577.6	27.0	112.0
256	SEG53	3037.5	577.6	27.0	112.0

Pin	Name	X	Y	W	H
257	SEG54	2992.5	577.6	27.0	112.0
258	SEG55	2947.5	577.6	27.0	112.0
259	SEG56	2902.5	577.6	27.0	112.0
260	SEG57	2857.5	577.6	27.0	112.0
261	SEG58	2812.5	577.6	27.0	112.0
262	SEG59	2767.5	577.6	27.0	112.0
263	SEG60	2722.5	577.6	27.0	112.0
264	SEG61	2677.5	577.6	27.0	112.0
265	SEG62	2632.5	577.6	27.0	112.0
266	SEG63	2587.5	577.6	27.0	112.0
267	SEG64	2542.5	577.6	27.0	112.0
268	SEG65	2497.5	577.6	27.0	112.0
269	SEG66	2452.5	577.6	27.0	112.0
270	SEG67	2407.5	577.6	27.0	112.0
271	SEG68	2362.5	577.6	27.0	112.0
272	SEG69	2317.5	577.6	27.0	112.0
273	SEG70	2272.5	577.6	27.0	112.0
274	SEG71	2227.5	577.6	27.0	112.0
275	SEG72	2182.5	577.6	27.0	112.0
276	SEG73	2137.5	577.6	27.0	112.0
277	SEG74	2092.5	577.6	27.0	112.0
278	SEG75	2047.5	577.6	27.0	112.0
279	SEG76	2002.5	577.6	27.0	112.0
280	SEG77	1957.5	577.6	27.0	112.0
281	SEG78	1912.5	577.6	27.0	112.0
282	SEG79	1867.5	577.6	27.0	112.0
283	SEG80	1822.5	577.6	27.0	112.0
284	SEG81	1777.5	577.6	27.0	112.0
285	SEG82	1732.5	577.6	27.0	112.0
286	SEG83	1687.5	577.6	27.0	112.0
287	SEG84	1642.5	577.6	27.0	112.0
288	SEG85	1597.5	577.6	27.0	112.0
289	SEG86	1552.5	577.6	27.0	112.0
290	SEG87	1507.5	577.6	27.0	112.0
291	SEG88	1462.5	577.6	27.0	112.0
292	SEG89	1417.5	577.6	27.0	112.0
293	SEG90	1372.5	577.6	27.0	112.0
294	SEG91	1327.5	577.6	27.0	112.0
295	SEG92	1282.5	577.6	27.0	112.0
296	SEG93	1237.5	577.6	27.0	112.0
297	SEG94	1192.5	577.6	27.0	112.0
298	SEG95	1147.5	577.6	27.0	112.0
299	SEG96	1102.5	577.6	27.0	112.0
300	SEG97	1057.5	577.6	27.0	112.0
301	SEG98	1012.5	577.6	27.0	112.0
302	SEG99	967.5	577.6	27.0	112.0
303	SEG100	922.5	577.6	27.0	112.0
304	SEG101	877.5	577.6	27.0	112.0
305	SEG102	832.5	577.6	27.0	112.0
306	SEG103	787.5	577.6	27.0	112.0
307	SEG104	742.5	577.6	27.0	112.0
308	SEG105	697.5	577.6	27.0	112.0
309	SEG106	652.5	577.6	27.0	112.0
310	SEG107	607.5	577.6	27.0	112.0
311	SEG108	562.5	577.6	27.0	112.0
312	SEG109	517.5	577.6	27.0	112.0
313	SEG110	472.5	577.6	27.0	112.0
314	SEG111	427.5	577.6	27.0	112.0
315	SEG112	382.5	577.6	27.0	112.0
316	SEG113	337.5	577.6	27.0	112.0
317	SEG114	292.5	577.6	27.0	112.0
318	SEG115	247.5	577.6	27.0	112.0
319	SEG116	202.5	577.6	27.0	112.0
320	SEG117	157.5	577.6	27.0	112.0
321	SEG118	112.5	577.6	27.0	112.0

Pin	Name	X	Y	W	H
322	SEG119	67.5	577.6	27.0	112.0
323	SEG120	22.5	577.6	27.0	112.0
324	SEG121	-22.5	577.6	27.0	112.0
325	SEG122	-67.5	577.6	27.0	112.0
326	SEG123	-112.5	577.6	27.0	112.0
327	SEG124	-157.5	577.6	27.0	112.0
328	SEG125	-202.5	577.6	27.0	112.0
329	SEG126	-247.5	577.6	27.0	112.0
330	SEG127	-292.5	577.6	27.0	112.0
331	SEG128	-337.5	577.6	27.0	112.0
332	SEG129	-382.5	577.6	27.0	112.0
333	SEG130	-427.5	577.6	27.0	112.0
334	SEG131	-472.5	577.6	27.0	112.0
335	SEG132	-517.5	577.6	27.0	112.0
336	SEG133	-562.5	577.6	27.0	112.0
337	SEG134	-607.5	577.6	27.0	112.0
338	SEG135	-652.5	577.6	27.0	112.0
339	SEG136	-697.5	577.6	27.0	112.0
340	SEG137	-742.5	577.6	27.0	112.0
341	SEG138	-787.5	577.6	27.0	112.0
342	SEG139	-832.5	577.6	27.0	112.0
343	SEG140	-877.5	577.6	27.0	112.0
344	SEG141	-922.5	577.6	27.0	112.0
345	SEG142	-967.5	577.6	27.0	112.0
346	SEG143	-1012.5	577.6	27.0	112.0
347	SEG144	-1057.5	577.6	27.0	112.0
348	SEG145	-1102.5	577.6	27.0	112.0
349	SEG146	-1147.5	577.6	27.0	112.0
350	SEG147	-1192.5	577.6	27.0	112.0
351	SEG148	-1237.5	577.6	27.0	112.0
352	SEG149	-1282.5	577.6	27.0	112.0
353	SEG150	-1327.5	577.6	27.0	112.0
354	SEG151	-1372.5	577.6	27.0	112.0
355	SEG152	-1417.5	577.6	27.0	112.0
356	SEG153	-1462.5	577.6	27.0	112.0
357	SEG154	-1507.5	577.6	27.0	112.0
358	SEG155	-1552.5	577.6	27.0	112.0
359	SEG156	-1597.5	577.6	27.0	112.0
360	SEG157	-1642.5	577.6	27.0	112.0
361	SEG158	-1687.5	577.6	27.0	112.0
362	SEG159	-1732.5	577.6	27.0	112.0
363	SEG160	-1777.5	577.6	27.0	112.0
364	SEG161	-1822.5	577.6	27.0	112.0
365	SEG162	-1867.5	577.6	27.0	112.0
366	SEG163	-1912.5	577.6	27.0	112.0
367	SEG164	-1957.5	577.6	27.0	112.0
368	SEG165	-2002.5	577.6	27.0	112.0
369	SEG166	-2047.5	577.6	27.0	112.0
370	SEG167	-2092.5	577.6	27.0	112.0
371	SEG168	-2137.5	577.6	27.0	112.0
372	SEG169	-2182.5	577.6	27.0	112.0
373	SEG170	-2227.5	577.6	27.0	112.0
374	SEG171	-2272.5	577.6	27.0	112.0
375	SEG172	-2317.5	577.6	27.0	112.0
376	SEG173	-2362.5	577.6	27.0	112.0
377	SEG174	-2407.5	577.6	27.0	112.0
378	SEG175	-2452.5	577.6	27.0	112.0
379	SEG176	-2497.5	577.6	27.0	112.0
380	SEG177	-2542.5	577.6	27.0	112.0
381	SEG178	-2587.5	577.6	27.0	112.0
382	SEG179	-2632.5	577.6	27.0	112.0
383	SEG180	-2677.5	577.6	27.0	112.0
384	SEG181	-2722.5	577.6	27.0	112.0
385	SEG182	-2767.5	577.6	27.0	112.0
386	SEG183	-2812.5	577.6	27.0	112.0

Pin	Name	X	Y	W	H
387	SEG184	-2857.5	577.6	27.0	112.0
388	SEG185	-2902.5	577.6	27.0	112.0
389	SEG186	-2947.5	577.6	27.0	112.0
390	SEG187	-2992.5	577.6	27.0	112.0
391	SEG188	-3037.5	577.6	27.0	112.0
392	SEG189	-3082.5	577.6	27.0	112.0
393	SEG190	-3127.5	577.6	27.0	112.0
394	SEG191	-3172.5	577.6	27.0	112.0
395	SEG192	-3217.5	577.6	27.0	112.0
396	SEG193	-3262.5	577.6	27.0	112.0
397	SEG194	-3307.5	577.6	27.0	112.0
398	SEG195	-3352.5	577.6	27.0	112.0
399	SEG196	-3397.5	577.6	27.0	112.0
400	SEG197	-3442.5	577.6	27.0	112.0
401	SEG198	-3487.5	577.6	27.0	112.0
402	SEG199	-3532.5	577.6	27.0	112.0
403	SEG200	-3577.5	577.6	27.0	112.0
404	SEG201	-3622.5	577.6	27.0	112.0
405	SEG202	-3667.5	577.6	27.0	112.0
406	SEG203	-3712.5	577.6	27.0	112.0
407	SEG204	-3757.5	577.6	27.0	112.0
408	SEG205	-3802.5	577.6	27.0	112.0
409	SEG206	-3847.5	577.6	27.0	112.0
410	SEG207	-3892.5	577.6	27.0	112.0
411	SEG208	-3937.5	577.6	27.0	112.0
412	SEG209	-3982.5	577.6	27.0	112.0
413	SEG210	-4027.5	577.6	27.0	112.0
414	SEG211	-4072.5	577.6	27.0	112.0
415	SEG212	-4117.5	577.6	27.0	112.0
416	SEG213	-4162.5	577.6	27.0	112.0
417	SEG214	-4207.5	577.6	27.0	112.0
418	SEG215	-4252.5	577.6	27.0	112.0
419	SEG216	-4297.5	577.6	27.0	112.0
420	SEG217	-4342.5	577.6	27.0	112.0
421	SEG218	-4387.5	577.6	27.0	112.0
422	SEG219	-4432.5	577.6	27.0	112.0
423	SEG220	-4477.5	577.6	27.0	112.0
424	SEG221	-4522.5	577.6	27.0	112.0
425	SEG222	-4567.5	577.6	27.0	112.0
426	SEG223	-4612.5	577.6	27.0	112.0
427	SEG224	-4657.5	577.6	27.0	112.0
428	SEG225	-4702.5	577.6	27.0	112.0
429	SEG226	-4747.5	577.6	27.0	112.0
430	SEG227	-4792.5	577.6	27.0	112.0
431	SEG228	-4837.5	577.6	27.0	112.0
432	SEG229	-4882.5	577.6	27.0	112.0
433	SEG230	-4927.5	577.6	27.0	112.0
434	SEG231	-4972.5	577.6	27.0	112.0
435	SEG232	-5017.5	577.6	27.0	112.0
436	SEG233	-5062.5	577.6	27.0	112.0
437	SEG234	-5107.5	577.6	27.0	112.0
438	SEG235	-5152.5	577.6	27.0	112.0
439	SEG236	-5197.5	577.6	27.0	112.0
440	SEG237	-5242.5	577.6	27.0	112.0
441	SEG238	-5287.5	577.6	27.0	112.0
442	SEG239	-5332.5	577.6	27.0	112.0
443	SEG240	-5377.5	577.6	27.0	112.0
444	COM1	-5422.5	577.6	27.0	112.0

TRAY INFORMATION

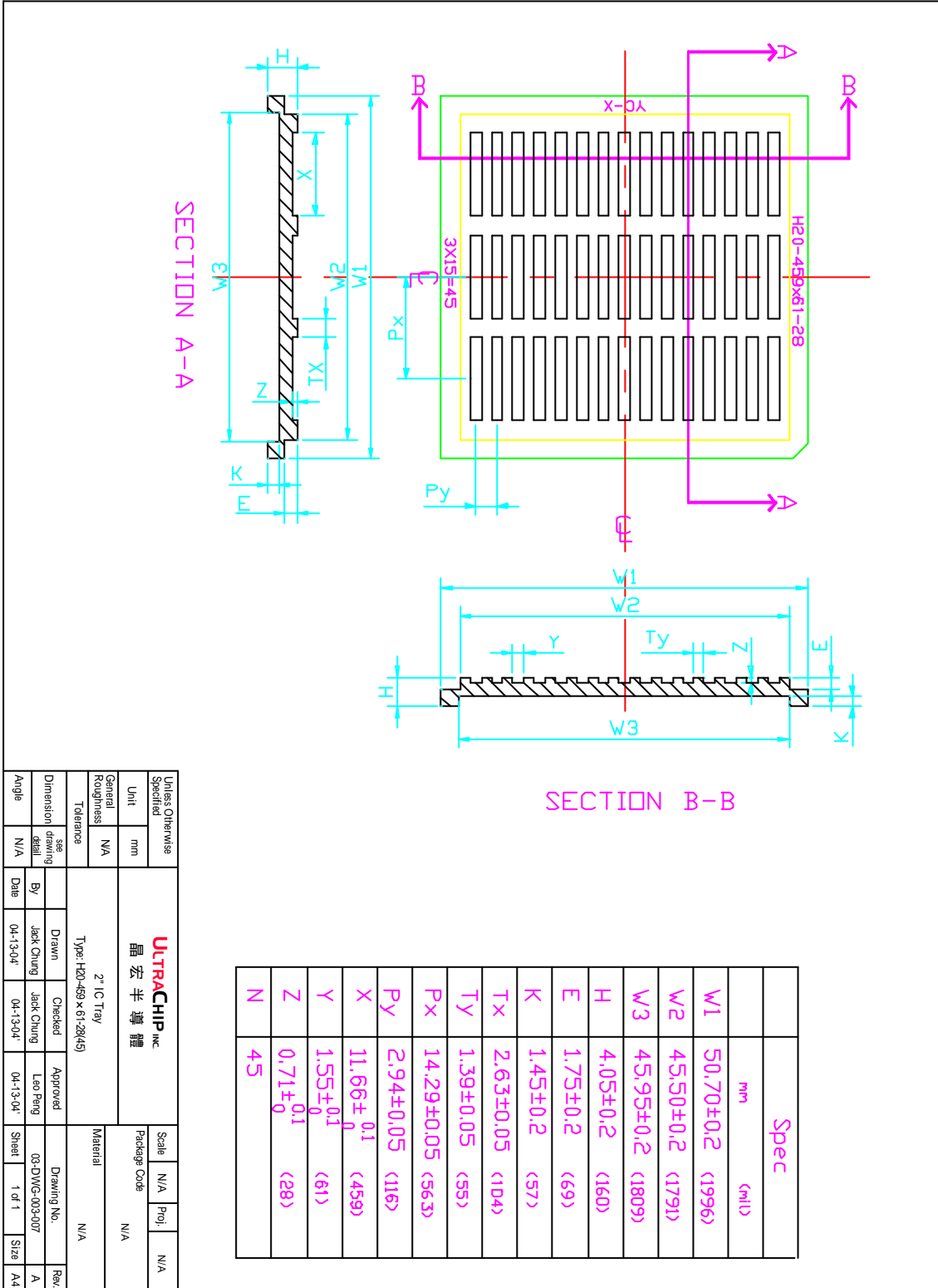

COF INFORMATION

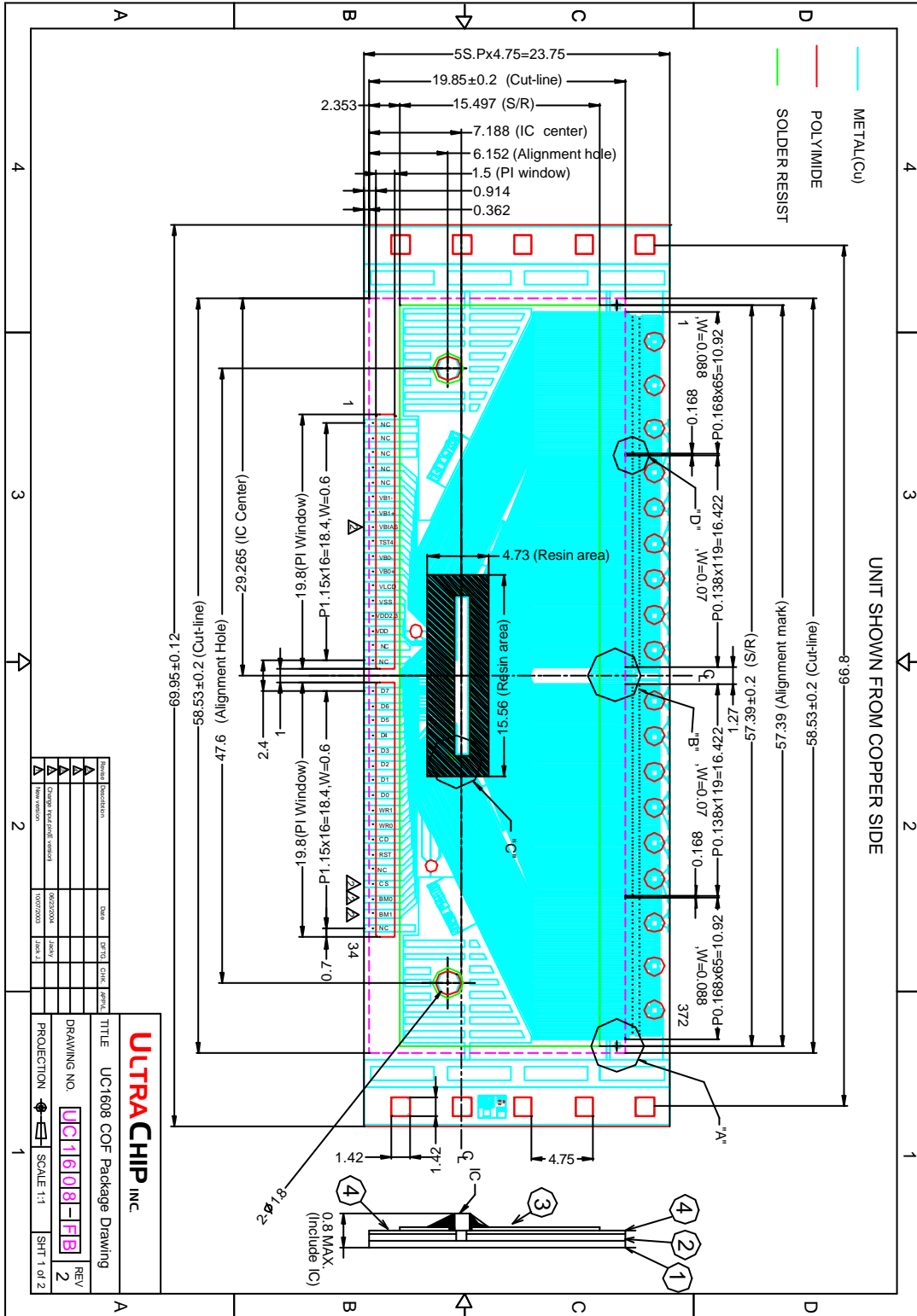

REVISION HISTORY

Revision	Contents	Date of Rev.
0.6	Golden Release	Jul. 2, 2004
0.8	(1) A constraint is added: To keep V_{DD} and V_{SS} under 150 O. (Section "Reference COG Layout", page 7; Section "ITO Layout Considerations", page 21)	Jul. 30, 2004
	(2) Die size was changed to 11480 x 1375. (Section "Revision History" – item 12, page 53)	
	(3) The Revision records prior to ES revision are split into a separate file. (Section "Revision History", page 53)	
1.0	(1) Some texts are marked bold to indicate default. (Section "Control Registers", Pp 8~9; "Command Description" – (5) Set Multiplex Rate, page 11; "Command Description" - (19) Set LCD Bias Ratio, page 15)	Sep. 30, 2004
	(2) $V_{DD2/3}$ is corrected. (Section "LCD Voltage Setting", page 16)	
	(3) Note item 1, the recommended C_{BIAS} range is adjusted: 50nF → 0.1 μ F (Section " V_{LCD} Quick Reference" – Hi-V Reference Circuit, page 19)	
	(4) Some AC timings are adjusted. (Section "AC Characteristics", Pp 39-40)	
1.1	(1) One more pin is added: V_{DDX} (Section "Pin Description", page 6)	Nov. 4, 2004
	(2) The COG drawing is updated: $V_{DD} \rightarrow V_{DDX}$ (Section "COG Reference Layout", page 7)	
	(3) Pin 68 is renamed: $V_{DD} \rightarrow V_{DDX}$ (Section "Pad Coordinates", page 46)	
	(4) In the "Operating Mode" table, the status of Draining Circuit in Sleep mode is corrected: "OFF" → "ON"	
	(5) Most contents of sub-section "Changing Operation Mode" are re-written. (Section "Reset & Power Management", page 33)	
	(6) Sub-section "Extended Display OFF" is removed.	
	(7) Sub-section "Brief Display OFF" is renamed as "Display OFF". (Section "Reset & Power Management", page 36)	
	(8) Average Frame Rate, f_{FR} , is adjusted: Max. : 84 → "-" (dash) (Section "Specifications" – DC Characteristics, page 38)	
	(9) A typo error is corrected: BR=11b → 10b	
	(10) Test Condition (2) is removed. (Section "Specifications" – Power Consumption, page 38)	