

SCALE : 0.8X

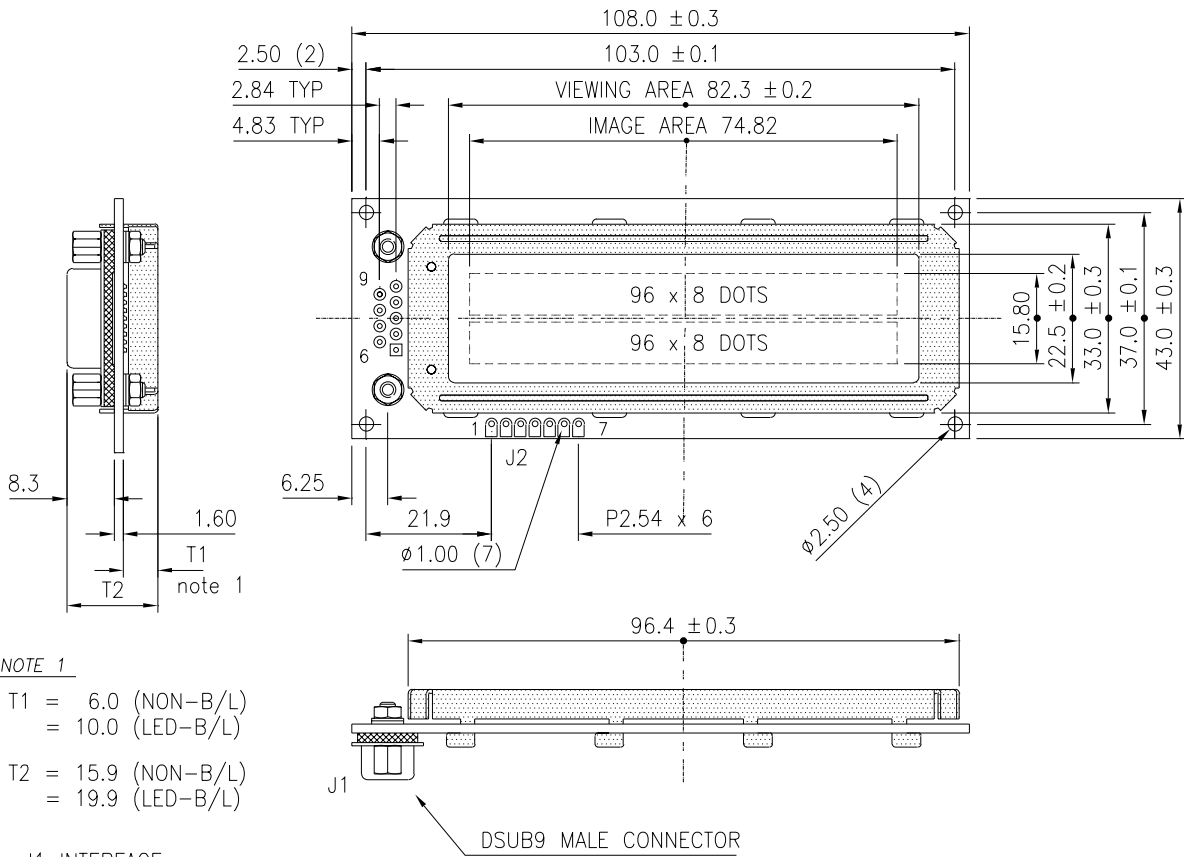

NOTE 1

- T1 = 6.0 (NON-B/L)
= 10.0 (LED-B/L)
- T2 = 15.9 (NON-B/L)
= 19.9 (LED-B/L)

J1 INTERFACE

PIN NO.	FUNCTION	SIGNAL NAME FROM PC SERIAL PORT	PIN NO.	FUNCTION	SIGNAL NAME FROM PC SERIAL PORT
1	NC	DCD	6	NC	DSR
2	NC	RxD	7	SRL PWR2	RTS
3	RS232 DATA IN	TxD	8	NC	CTS
4	SRL PWR1	DTR	9	NC	RI
5	Vss	SG			

J2 INTERFACE

* to be used only if SPI is selected

PIN NO.	1	2	3	4	5*	6*	7*
FUNCTION	VSS	VDD	LED+	DATA_IN	SPI_CS	SPI_CLK	SPI_BUSY

**ASCII input
Direct-plug-in to COM port**

Item	Symbol	Condition	Min.		Typ.	Max.		Unit
			N	W		N	W	
Operating Temperature	Top		0	-20		50	70	°C
Storage Temperature	Tstg		-10	-30		60	80	°C
Supply for Logic (if J2 is used)	Vcc-Vss	Ta= 25°C	4.5		5.0	5.5		V
Supply Current Drain	Icc	Ta= 25°C			5.0			mA
Backlight Current Drain	I _{BL}	Ta= 25°C			270			mA
SPI CLK Frequency	f _{CLK}	Ta= 25°C				18		kHz

RS232 Baud Rates (via DIP switch settings)	1200	2400	4800	9600

FEATURE HIGHLIGHTS :

- Built-in Software Control for Contrast and Backlighting
- Smooth Horizontal Scrolling
- Gapless Bar Graphing

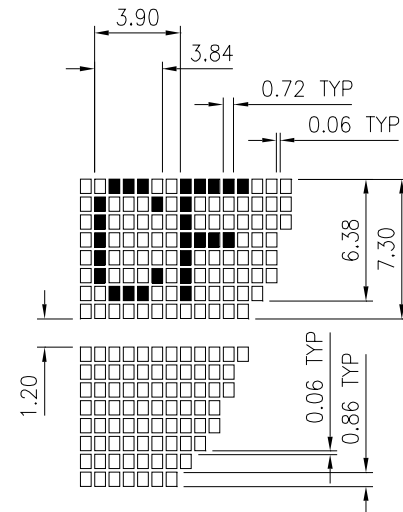

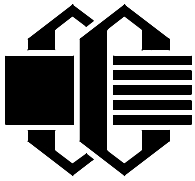

Connecting Your CrystalFontz Intelligent Serial Display

Connection to Personal Computers

For non-backlight operation when the display is connected to a PC's 9-pin serial port, all you need is a "straight through" 9-pin female DB9 to 9-pin female DB9 cable. This cable is available from CrystalFontz as part number WR232Y01, or from Radio Shack as Cat No 26-152.

This is a view looking into the male DB9 connector on CrystalFontz Display.

Pin Number	CrystalFontz Display Function	Corresponding PC pin name
1	Not Connected	DCD (Data Carrier Detect)
2	Not Connected	Rx (Receive Data)
3	Data In	Tx (Transmit Data)
4	Power A (9 volts to 15 volts)	DTR (Data Terminal Ready)
5	Ground (Vss)	Signal Ground
6	Connected to Power A if JPD is closed	DSR (Data Set Ready)
7	Power B (9 volts to 15 volts)	RTS (Request To Send)
8	Connected to Power B if JPC is closed	CTS (Clear To Send)
9	Not Connected	RI (Ring Indicator)

Most RS-232 ports will be able to power the display through their DTR and RTS lines. Just have the software drive these lines high—most software already will.

To power the backlight, you must connect a regulated 5v supply capable of sourcing 600mA to the LED+ terminal of the LCD's solder connector. The supply's ground should connect to the Vss terminal of the LCD's solder connector:

Pin Number	Pin Name	CrystalFontz Display Function
1	Vss	Ground (backlight and controller)
2	Vdd	Controller and LCD power (+5volt only)
3	LED+	LED Backlight power (+5volt only)
4	DATA_IN	SPI or RS-232 data in (input)
5	/SPI_CS	SPI Chip Select (active low input)
6	SPI_CLK	SPI Clock (input)
7	SPI_BUSY	SPI Busy (output)

The easiest place on a PC to get 5v is from a disk drive power connector. The red wire is typically 5v, the black wires are typically ground. CrystalFontz sells a cable that will connect from a spare power connector on your PC to the display's LED backlight. The cable is part number WR232Y02. If you make your own cable, be sure and measure the output voltage before you connect the display. The colors are usually correct, but some computers may have non-conventional colors.

WARNING: Do not use the yellow wire of the disk drive power cable. This wire is typically the 12 volt supply and will ruin the display if it is connected instead of 5 volts.

Connections in Embedded Systems

To connect the display in most embedded systems, you need only use the LCD's solder connector. This connector has standard 0.1 inch spacing. Generally, you would connect a regulated 5v supply for the controller to Vdd, Ground to Vss, and RS-232 data to DATA_IN. DATA_IN will accept full +10v to -10v swing RS-232 signals and will also accept 0v to 5v "CMOS" or "TTL" levels. If your RS-232 data is inverted, you can close JPB.

If you would like, you can connect an unregulated 9 volt to 15 volt supply to Power A or Power B of the DB9 connector instead of connecting a regulated +5 volt supply to Vdd. Power A and Power B will only power the LCD itself, not the backlight. Do not connect a supply greater than 5.25 volts to Vdd or LED+. Damage to your LCD module will result.

To use the backlight, connect a regulated 5v supply capable of sourcing 600mA to the LED+ terminal. This may be the same supply that is used for Vdd. The backlight brightness is controlled by PWM (Pulse Width Modulation). The PWM may cause noise on supplies that have high output impedance. If this noise causes problems in your application, you may want to connect a filter capacitor from Vdd to Vss close to the display, or operate the backlight at full brightness, which disables the PWM.

To use the SPI interface, close JPA. Please refer to the SPI timing diagrams in the data sheet. In some situations, the SPI interface can deliver data faster than the display can execute the commands. The host should check the SPI_BUSY line and wait for it to go low before sending the next SPI data.

Handshaking

The display can execute commands faster than the RS-232 serial interface can deliver them, so no handshaking is necessary from the display's point of view.

Some host hardware or software may require the display to assert its DSR and/or CTS lines before it will send data to the display. In that case, JPC and/or JPD may be closed. Closing JPC will connect DSR to DTR through a 1K resistor. Closing JPD will connect CTS to RTS through a 1K resistor.

Crystalfontz Intelligent Serial Display Jumper Settings

Your display has four jumpers. The jumpers are normally open. The jumpers may be closed by melting a ball of solder across their gap. You may re-open the jumpers by removing the solder (solder-wick works well for this). The following table describes the jumper's operation:

Jumper	State	Function
JPA	Open	RS-232 interface selected
	Closed	SPI interface selected
JPB	Open	RS-232 data is normal
	Closed	RS-232 data is inverted
JPC	Open	DSR is open
	Closed	DTR is fed back on DSR through 1K resistor
JPD	Open	CTS is open
	Closed	RTS is fed back on CTS through 1K resistor

Crystalfontz Technology

20x4 and 16x2 intelligent serial interface display command set

This document corresponds with firmware v1.2.

For "binary" data the notation \xxx is used, where xxx is the decimal representation of the number. \000 to \255 cover all possible values. This same notation is supported by the free Crystalfontz WinTest utility software.

Some keyboards will not be able to create all the codes. We recommend you use Crystalfontz WinTest utility to send the examples to the display. You may highlight each line of the examples, copy them, and then past them into the WinTest edit box with a right-click, "Paste". Be sure **not** to highlight the invisible carriage return at the end of the line.

The display will power itself (without the backlight) from the DTR and RTS control lines on most PC serial ports. Supply +5 volts and ground to use the backlight.

The cable is a 9-pin female to 9-pin female, "straight through". Radio Shack 26-125 works great with the "AT" compatible 9-pin serial port available on most PCs.

The baud is set with the dip switches:

Switch 1	Switch 2	Baud
Up(on)	Up(on)	= 9600
Down(off)	Up(on)	= 4800
Up(on)	Down(off)	= 2400
Down(off)	Down(off)	= 1200

"Inverted RS-232" and "Low-Speed SPI" may be selected by closing jumpers. See Appendix A: Interface Options.

Display Control Codes

ASCII	Keystrokes	Function
\000	Control @	Null
\001	Control A	Cursor Home
\002	Control B	Hide Display
\003	Control C	Restore Display
\004	Control D	Hide Cursor
\005	Control E	Show Underline Cursor
\006	Control F	Show Block Cursor
\007	Control G	Show Inverting Block Cursor
\008	Control H	Backspace (destructive)
\009	Control I	<i>not used</i>
\010	Control J	Line Feed
\011	Control K	Delete in place
\012	Control L	Form Feed (Clear Display)
\013	Control M	Carriage Return
\014	Control N	Backlight Control
\015	Control O	Contrast Control
\016	Control P	<i>not used</i>
\017	Control Q	Set Cursor Position (Column and Row)
\018	Control R	Horizontal Bar Graph
\019	Control S	Scroll ON

\020	Control T	Scroll OFF
\021	Control U	Set Scrolling Marquee Characters
\022	Control V	Enable Scrolling Marquee
\023	Control W	Wrap ON
\024	Control X	Wrap OFF
\025	Control Y	Set Custom Character Bitmap
\026	Control Z	Reboot
\027	Escape	Escape Sequence Prefix
\028	Control Backslash	Large Block Number (3x4 or 4x4)
\029	Control Quote	<i>not used</i>
\030	Control Equal	Send Data Directly to the LCD Controller
\031	Control Minus	Show Information Screen
\128		Custom Character 0
\129		Custom Character 1
\130		Custom Character 2
\131		Custom Character 3
\132		Custom Character 4
\133		Custom Character 5
\134		Custom Character 6
\135		Custom Character 7

Explanation of Control Functions

Cursor Home (\001 , Control A)

Moves cursor to the top left character position. No data is changed. Identical to Control Q,0,0.

Hide Display (\002 , Control B)

Display is blanked, no data is changed.

Restore Display (\003 , Control C)

Restores blanked display; nothing else is changed.

Hide Cursor (\004 , Control D)

Cursor is *not* shown; nothing else is changed.

Show Underline Cursor (\005 ; Control E)

Shows a non-blinking underline cursor at the printing location.

Show Block Cursor (\006 ; Control F)

Shows a blinking block cursor at the printing location.

Show Inverting Block Cursor (\007 ; Control G)

Shows a blinking block cursor at the printing location. This cursor inverts the character rather than replacing the character with a block. This cursor style is the default cursor at power-up.

Backspace (\008 ; Control H)

Moves the cursor back one space and erases the character in that space. Will wrap from the left-most column to the right-most column of the line above. Will wrap from the left-most column of the first row to the right-most column of the last row.

Line Feed (\010 ; Control J {also Control Enter on some keyboards})

Moves the cursor down one row. If SCROLL is on and the cursor is at the bottom row, the display will scroll up one row and the bottom row will be cleared. If SCROLL is off, and the cursor is at the bottom row, it will wrap up to the same character position on the top row.

Delete in place (\011 ; Control K)

Deletes the character at the current cursor position. Cursor is not moved.

Form Feed (\012 ; Control L)

Clears the display and returns cursor to Home position (upper left). All data is erased.

Carriage Return (\013 ; Control M)

Moves cursor to the left-most column of the current row.

Backlight Control (\014 ; Control N)

Send "Control-N", followed by a byte from 0-100 for the backlight brightness. 0=OFF; 100=ON , intermediate values will vary the brightness. There are a total of 25 possible brightness levels.

Examples:

\014\000
\014\050
\014\100

Contrast Control (\015 ; Control O)

Send "Control O", followed by a byte from 0-100 for the contrast setting of the displayed characters. 0 = very light, 100 = very dark, 50 is typical. There are a total of 25 possible contrast levels.

Examples:

\015\040
\015\050
\015\060

Set Cursor Position (Column and Row) (\017 ; Control Q)

Send "Control Q" followed by one byte for the column (0-19 for a 20x4 display, or 0-15 for a 16x2 display), and a second byte for the row (0-3 for a 4x20 or 0-1 for a 2x16). The upper-left position is 0,0. The lower-right position is 15,1 for a 16x2, and 19,3 for a 20x4. Here is an example for moving the cursor to column 11 of the second line:

\017\010\001

Horizontal Bar Graph (\018 ; Control R)

Send "Control R" followed by the following bytes:

graph_index
style
start_column
end_column
length
row

graph_index determines which special characters are used:

graph_index	custom characters used
\000	0,1
\001	2,3
\002	4,5
\003	6,7

style is the bit pattern to use in drawing the graph:

\255 (11111111b) is a thick bar

\000 (00000000b) will not be visible (all pixels are off)
\085 (01010101b) is a striped bar
\060 (00111100b) is a medium width bar, centered
\015 (00001111b) is a medium width bar, low in the row
\240 (11110000b) is a medium width bar, high in the row

any value is valid between \000 and \255, the msb is at the top of the row, the lsb is at the bottom of the row.

start_column and **end_column** are the character X coordinates of the graph area. Each must be between \000 and \019 for the 20x4 or between \000 and \015 for the 16x2. start_column must be less than or equal to end_column.

length is the length in pixels of the graph. Positive values will graph from the left edge of **start_column**, negative values will graph from the right edge of **end_column**. There are six pixels per character, so the maximum value of length for a 20x4 display is $20 \times 6 = 120$. For a 16x2, the maximum value is $16 \times 6 = 96$.

row is the character Y coordinate. \000-\003 is valid for the 20x4, \000-\001 is valid for the 16x2.

Examples:

```
\018\000\255\000\014\010\001  
\018\000\015\000\014\236\001
```

Notes:

The entire graph area is completely re-written by each graph command, so there is no need to clear the area between successive updates of the same graph. If a length of \000 is written the entire graph area is cleared to spaces. Negative values can be calculated as $256 - \text{value}$. For instance if you want a graph to extend 20 pixels towards the left, from the rightmost column of the graph area, send 236 ($256 - 20 = 236$). No additional graph "setup" command is needed.

The graphs use some of the custom characters, and so may goof up the display if there are user-defined custom characters or large numbers shown.

Scroll ON (\019 ; Control S)

Turns Scroll feature ON. Then a **Line Feed** (Control J) command from the bottom row will scroll the display up by one row, independent of **Wrap**. If **Wrap** is also on, a wrap occurring on the bottom row will cause the display to scroll up one row. Scroll is on at power up.

Scroll OFF (\020 ; Control T)

Turns Scroll feature OFF. Then a **Line Feed** (Control J) command from the bottom row will move the cursor to the top row of the same column, independent of **Wrap**. If **Wrap** is also on, a wrap occurring on the bottom row will also wrap vertically to the top row. Scroll is on at power up.

Set Scrolling Marquee Characters (\021 ; Control U)

Send "Control U" followed by the following bytes:

index
character

index determines which of the 20 scrolling marquee characters gets set, \000 to \019 are valid

character is the value that this position in the scrolling marquee will be set to

Examples:

This will set the first 12 characters to "Crystalfontz", put another message on the display, and enable the scrolling marquee. The second line of this example ends in a space:

```
\004\022\255\001\005\012\017\000\001Scrolling Marquee  
\021\000c\021\001r\021\002y\021\003s\021\004t\021  
\005a\021\006l\021\007f\021\008o\021\009n\021\010t  
\021\011z\021\012 \021\013 \021\014 \021\015 \021  
\016 \021\017 \021\018 \021\019 \022\001\001\016
```

Notes:

There is a section of memory that holds 20 hidden characters. These 20 characters, along with the contents of one line of the display can be rotated pixel by pixel across the display in a circular fashion. Use this command multiple times to set the 20 hidden characters. Use the normal display functions to set the other characters in the line you want to rotate, then enable rotation with **Enable Scrolling Marquee** command. The hidden characters are set to blanks at power-up.

You will probably want to disable the scrolling marquee movement while you are setting the scrolling marquee characters or modifying characters on the rotating line. You will probably also want to move the cursor off the line or hide it.

WinTest, available at <http://www.crystalfontz.com> easily allows setting up the scrolling marquee and adjusting the parameters, so you can find a setting that is to your taste in a minimum amount of time.

Erratum:

If the first character of the line above the rotating line on a 20x4 display has any pixels on its bottom row set, they will appear as "ghost" pixels in the upper right of last character of the scrolling line. This will only happen on the first line or if the cursor or a custom character with its bottom row of pixels set is in the leftmost position of the line directly above the scrolling marquee line. These pixels are an artifact of the display controller memory architecture.

Enable Scrolling Marquee (\022 ; Control V)

Send "Control V" followed by the following bytes:

```
line  
scroll_step_size  
update_speed
```

line determines which line will scroll with the scrolling marquee, or if the scrolling marquee is disabled.

line	function
\000	enable scrolling marquee on line 1
\001	enable scrolling marquee on line 2
\002	enable scrolling marquee on line 3 (20x4 only)
\003	enable scrolling marquee on line 4 (20x4 only)
\255	disable scrolling marquee (valid values for scroll_step_size and update_speed must still be sent)

scroll_step_size controls the number of pixels that the message is shifted by at each update:

\001	shift by one pixel, smooth but slow
\002	shift by two pixels
\003	shift by three pixels
\004	shift by four pixels

\005 shift by five pixels
\006 shift by six pixels--equal to shifting by one character, fast

update_speed determines how often updates will happen. The units are 1/96 of a second, or about 10mS. The valid range is \005 (52mS) to \100 (1.042S).

Notes:

Since the liquid crystal fluid in the display takes some time to react, the minimum usable value is about 16 or 167mS. The command supports a large range of speed to accomodate future displays and user preference.

The following equations will allow you to determine the speed at which the message scrolls:

Update Frequency = **update_speed**/96 Hz
Update Period = 96/**update_speed** Seconds

New Character Frequency = (**scroll_step_size** * **update_speed**)/(96*6) Hz
New Character Period = (96*6)/(**scroll_step_size** * **update_speed**) Seconds

16x2 Message Repeat Period = (36*96*6)/(**scroll_step_size** * **update_speed**) Seconds
20x4 Message Repeat Period = (40*96*6)/(**scroll_step_size** * **update_speed**) Seconds

See the example in **Set Scrolling Marquee Characters** above. WinTest, available at <http://www.crystalfontz.com> easily allows setting up the scrolling marquee and adjusting the parameters, so you can find a setting that is to your taste in a minimum amount of time.

Wrap ON (\023 ; Control W)

Turns **Wrap** feature ON. Then, a printable character received when the cursor is at the right-most column will cause the cursor to move down one row, to the left-most column. If the cursor is already at the right-most column of the bottom row, it will wrap to the top row if **Scroll** is OFF, or the display will scroll up one row if **Scroll** is ON.

Wrap OFF (\024 ; Control X)

Turns **Wrap** feature OFF. Then, a printable character received when the cursor is at the right-most column will cause the cursor to disappear (as it will be off the right edge of the screen) and any subsequent characters will be ignored until some other command moves the cursor back onto the display. This function is independent of **Scroll**.

Set Custom Character Bitmap (\025 ; Control Y)

The custom characters are mapped at \128 through \135 corresponding to **character 0** to **character 7**. Send "Control Y" followed by the following bytes:

character
data0
data1
data2
data3
data4
data5
data6
data7

character determines which of the eight custom characters is modified. 0-7 is valid. The custom characters are displayed by sending \128 to \135:

To display custom character 0, send \128
To display custom character 1, send \129
To display custom character 2, send \130
To display custom character 3, send \131
To display custom character 4, send \132
To display custom character 5, send \133
To display custom character 6, send \134
To display custom character 7, send \135

data0-data7 are the bitmap information for this character. Any value is valid between 0 and 63, the msb is at the left of the character cell of the row, the lsb is at the right of the character cell. **data0** is at the top of the cell, **data7** is at the bottom of the cell.

Notes: The large digits use all of the custom characters, so if you modify the custom characters when large digits are displayed, the display will probably become corrupted. The bar graphs also use some of the custom characters.

Example:

```
\012\001\128\129\130\131\017\000\001\132\133\134\135  
\025\000\000\000\001\003\000\031\031\031  
\025\001\028\054\032\001\003\051\051\051  
\025\002\014\027\049\032\032\047\032\047  
\025\003\000\000\032\048\000\062\000\062  
\025\004\031\031\031\000\003\001\000\000  
\025\005\051\051\051\003\001\032\054\028  
\025\006\047\032\047\032\032\049\027\014  
\025\007\062\000\062\000\048\032\000\000
```

Reboot (\026 ; Control Z)

The firmware in your Crystalfontz Intelligent Display is very stable and robust, and it is not likely that you will ever need a "reboot" command. In fact, if the firmware actually did crash, the command processor would likely be inoperable and unable to detect the reboot command anyway. However, there may be certain situations where it is nice to have a command that will return the display to a known state. Perhaps the baud rate on the host was set to an incorrect speed. Then the data is interpreted as all sorts of meaningless garbage, which the display firmware tries to interpret. Some data may set the contrast to an unusable value, some data may program the LCD controller to an indeterminate state. Or perhaps you just always want the display to wake up in a given state when your program starts, without going through all the commands that affect the way the display interprets commands (like the state of **Scroll** or **Wrap**, for instance).

Send one "Control Z" followed by another "Control Z" to reboot the display. If you are not sure of the display state, it may be necessary to send up to 9 characters to satisfy the parameters of some previous command. As an example, say the **Set Custom Character Bitmap** command has just been received by the display when your PC's popular but unstable operating system crashes. The display will interpret the next 9 bytes as the parameters to the command, then wait for more commands. So if you are not sure what the status of the display is, send 9 blanks (\032) followed by two Control Zs (\026).

If the display in your system is powered by the serial port's RTS and DTR lines, the display can be rebooted by dropping those lines momentarily (say 500mS) and then bringing them high again.

Escape Sequences

There are 4 **Escape** sequences currently supported . These correspond to the escape sequences that are sent for the four arrows keys in HyperTerminal with an ANSI terminal selected (and also WinTest). These sequences move the cursor only, and do not wrap.

ESC [A (equivalent to \027\091\065)
UP arrow

ESC [B (equivalent to \027\091\066)
DOWN arrow

ESC [C (equivalent to \027\091\067)
RIGHT arrow

ESC [D (equivalent to \027\091\068)
LEFT arrow

Large Block Number (\028 ; Control Backslash)

This command is only valid on the 20x4. On the 16x2 it is parsed and then discarded. Send "Control Backslash" followed by the following bytes:

style
column
number

style determines if a 3x4 or a 4x4 large number is displayed:

style function

\000	3x4 large number
\001	4x4 large number
\002-\255	invalid

column is the starting column of the number. \000-\017 are valid for a style of \000 (3x4), \000-\016 are valid for a style of \001 (4x4).

number is the number to display. \048 to \057 ('0' to '9') are valid.

Notes:

The large numbers use all the custom characters. There will be some corruption if they are used at the same time as the graphs or user defined custom characters. There is no large number initialization command needed.

Examples:

```
\004\012\028\000\0010\028\000\0051\028\000\0092\028\000\0133\028\000\0174  
\004\012\028\000\0005\028\000\0046\028\000\0087\028\000\0128\028\000\0169
```

```
\004\012\028\001\0000\028\001\0051\028\001\0102\028\001\0153  
\004\012\028\001\0006\028\001\0057\028\001\0108\028\001\0159
```

Send Data Directly to the LCD Controller (\030 ; Control Equal)

Send "Control Equal" followed by the following bytes:

location
data

location is the destination register on the LCD controller:

location	register
\000	Control Register, (RS=0, RE=0)
\001	Data Memory, (RS=1, RE=x)
\002	Control Register, (RS=0, RE=1)

data is the data to write to the controller

Notes:

This command executes a low level write directly to the controller. Use this command at your own risk. Control Z, Control Z will reboot the display and recover from most mistakes.

Example:

```
\030\002\031\030\002\130
```

Show Information Screen (\031 ; Control Minus)

This command will show the baud rate, version and model number.

Appendix A: Interface Options

"Inverted RS-232" or "Low-Speed SPI" may be selected by closing jumpers.

"Inverted RS-232" is useful when the display is used with an embedded microcontroller's built-in UART. These UARTs typically output a logic level (0-5v) inverted version of the RS-232 waveform, ready to be passed into an RS-232 driver. By setting the display to accept inverted RS-232 data, you can connect this logic level signal directly to the display and avoid having the RS-232 driver. The display will show a lower case "i" before the baud rate on the information screen if the jumper is closed ("i9600bd").

"Low-Speed SPI" is intended to be used with low-end embedded microprocessors that lack a hardware UART. The reason that it is "Low-Speed" is that the SPI is done in firmware on the display. On the host microprocessor, any three general-purpose output ports and a small "send byte" routine can be used to control the display. If the host microprocessor has a hardware SPI port, that can be used, provided that the port's speed can be set to satisfy the timing constraints. A software state-machine and a timer interrupt could also be used, this would reduce the microprocessor's load while still satisfying the timing requirements. Another useful feature of SPI is that additional displays can be controlled with only one additional output port (SPI_CS) per display. All the other lines (/SPI_CLK and SPI_DATA) are common. The display will show "SPI" instead of the baud rate on the information screen.

The Crystalfontz intelligent serial display has a 32-character input buffer. For the RS-232 interface, it is impossible to overflow this buffer since the display can process commands more quickly than the 9600-baud RS-232 interface can deliver them, so no flow control is needed. If the your processor can deliver data through the Low-Speed SPI interface at a rate faster than 1000 bytes/second, then the processor should make sure the SPI_BUSY line is low before sending a new command. The SPI_BUSY line will be set high by the display when there are 16 or more characters in the display's input buffer, and returned low when there are less than 16 characters.

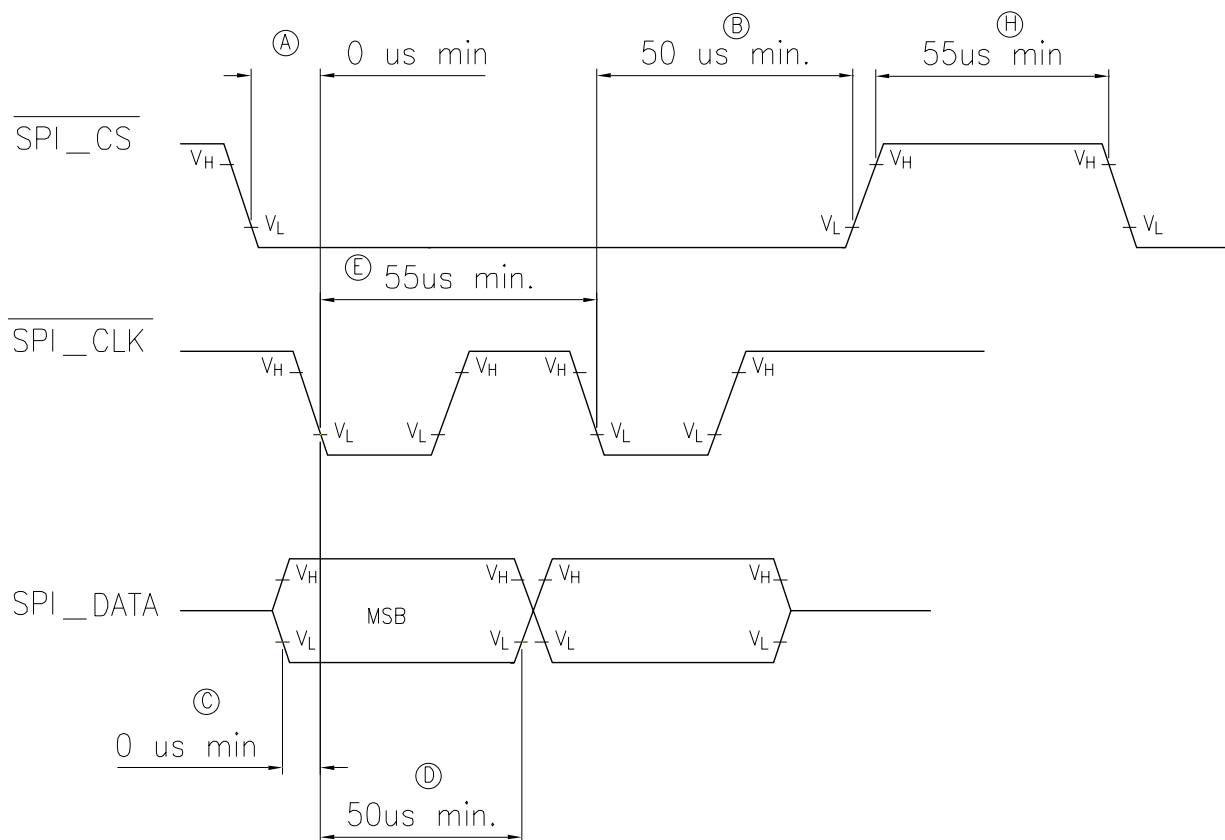

NOTES

- $\overline{\text{SPI_CS}}$ must be low before $\overline{\text{SPI_CLK}}$ falls
- $\overline{\text{SPI_CS}}$ must stay low for the entire transfer
- SPI_DATA must be correct before $\overline{\text{SPI_CLK}}$ falls
- SPI_DATA must be held for a minimum of 50 μs after $\overline{\text{SPI_CLK}}$ falls
- The maximum clock rate is $1/55\mu\text{s}$ or 18.182kHz
- Data is transferred MSB first; two out of eight cycles are shown
- $\text{CPOL} = 1$, $\text{CPHA} = 1$ for most processors
- Take $\overline{\text{SPI_CS}}$ high for a minimum of 55 μs to guarantee bit synchronisation
- Maximum throughput is $\frac{1}{9 \times 55} = 2020 \text{ bytes / second}$

ALL DIMENSIONS ARE IN MILLIMETRES

REVISIONS ARE INDICATED BY CIRCLED LETTERS

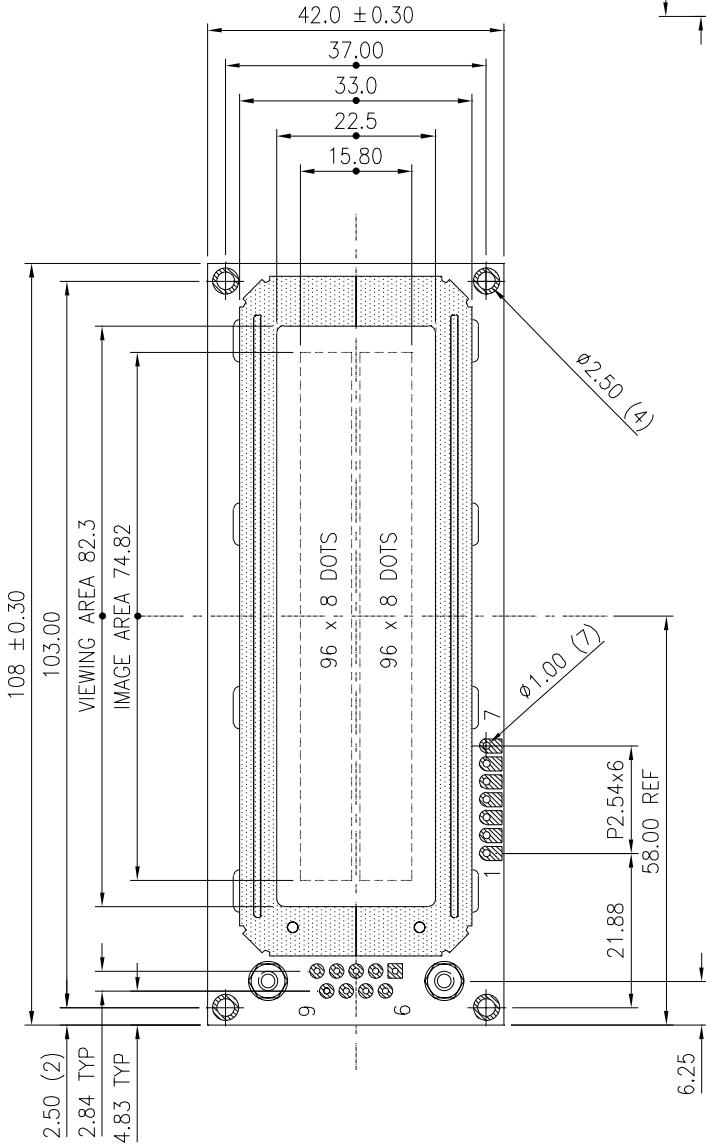

note 1

NOTE 1

- T1 = 6.0 (NON-B/L)
- = 10.0 (LED-B/L)
- T2 = 15.9 (NON-B/L)
- = 19.9 (LED-B/L)

THIS DRAWING IS APPLICABLE TO THE FOLLOWING SUB-VARIANTS :-

- SKD162-632SS (NON-BACKLIT, GRAY STN DISPLAY)
- SKD162-632SG-LG (LED-BACKLIT, YEL-GREEN STN DISPLAY)

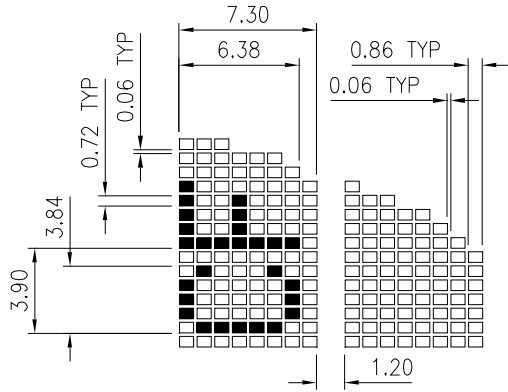
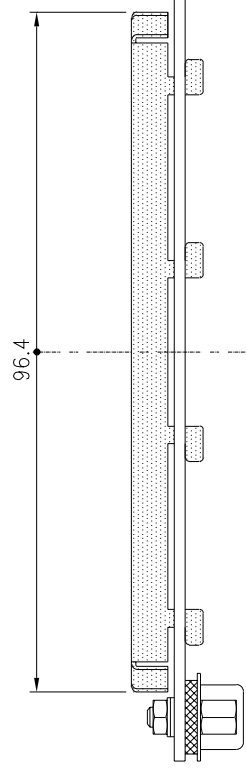

DISKETTE CY9818

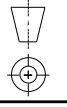
	TITLE MECHANICAL PRODUCT SPECIFICATIONS			SCALE 1 = 1 PROJECT 632	GEN. TOL. X.X = ± 0.20 X.XX = ± 0.10 ANG = ± 0.5°	DRAWN BY : ALEXIS APPROVED :	DWG NBR 9M632P01 DATE 01 JUNE 1999	REV B SHEET 1 OF 2
	DISKETTE CY9818							

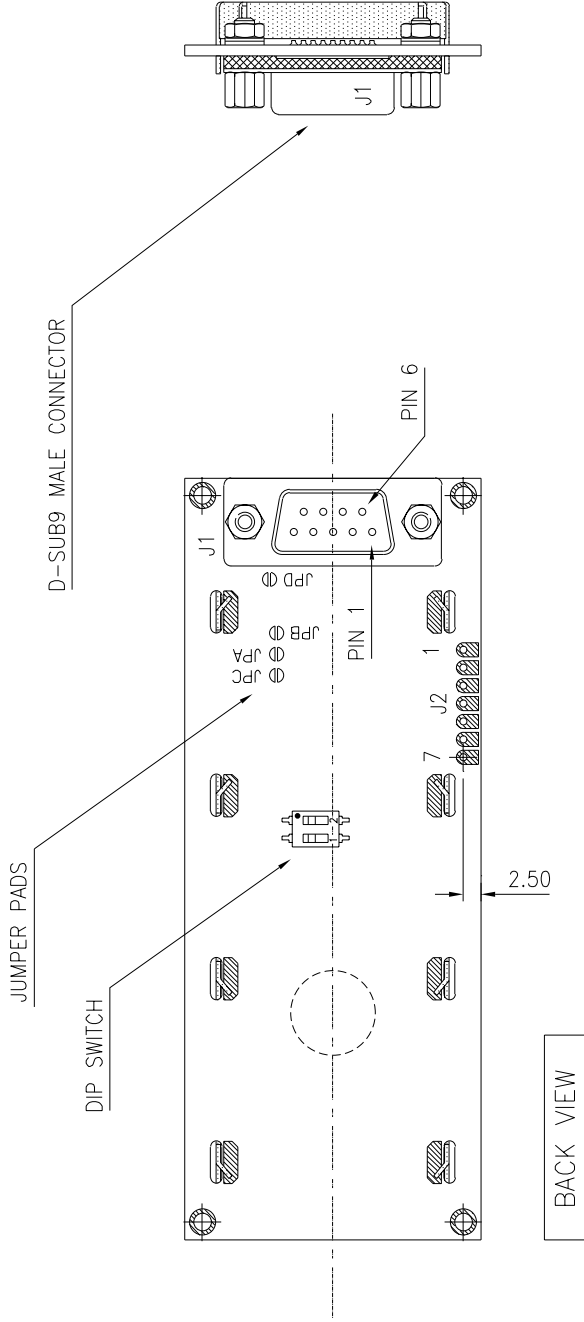

Ⓔ

J2 PIN-OUT DEFINITION	NAME	REMARKS / FUNCTION
1	VSS	GROUND
2	VDD	5V REG.SUPPLY
3	LED+	5V REG. LED B/L SUPPLY
4	DATA_IN	INPUT SIGNAL (RS232 OR SPI)
5	SPI_CS	CHIP SELECT FOR SPI
6	SPI_CLK	CLOCK FOR SPI
7	SPI_BUSY	BUSY FLAG FOR SPI

J1 PIN-OUT DEFINITION		SIGNAL NAME FROM PC SERIAL PORT
PIN NO.	FUNCTION	
1	NC	DCD
2	NC	RxD
3	RS232 DATA IN	TxD
4	SRL PWR1	DTR
5	VSS	SG
6	NC	DSR
7	SRL PWR2	RTS
8	NC	CTS
9	NC	RI

BAUD RATE	DIP SWITCH SETTINGS	
	PIN 1	PIN 2
1200	OFF	OFF
2400	ON	OFF
4800	OFF	ON
9600	ON	ON

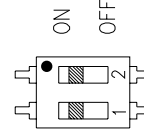

JPC JPA JPB JPD

Ⓕ

JUMPER PAD	CONDITION	
	OPEN	SHORT
JPA	RS232	SPI
JPB	NORMAL RS232	INVERTED RS232
JPC		
JPD		

THIS DRAWING IS APPLICABLE TO THE FOLLOWING SUB-VARIANTS :-

SKD162-632SS (NON-BACKLIT, GRAY STN DISPLAY)
SKD162-632SG-LG (LED-BACKLIT, YEL-GREEN STN DISPLAY)

DISKETTE CY9818

	TITLE	MECHANICAL PRODUCT SPECIFICATIONS	SCALE 1 = 1	GEN. TOL. X.X = ±0.20 X.XX = ±0.10 ANG = ±0.5°	DRAWN BY : ALEXIS	DWG NBR 9M632P01	REV B
	PROJECT 632	APPROVED :			DATE 01 JUNE 1999		SHEET 2 OF 2



CRYSTALFONTZ

v1.0

9600bd

BAV99
1700



CRYSTALFONTZ
SINGAPORE

NE555
NE555
NE555
NE555

