



GRAPHIC DISPLAY MODULE DATA SHEET



Data Sheet Release Date 2014-07-31
for the CFAG128128I-xxx-VZ:

[CFAG128128I-TFH-VZ](#)

[CFAG128128I-TMI-VZ](#)

[CFAG128128I-YYH-VZ](#)

Crystalfontz America, Incorporated

12412 East Saltese Avenue
Spokane Valley, WA 99216-0357

Phone: 888-206-9720

Fax: 509-892-1203

Email: support@crystalfontz.com

URL: www.crystalfontz.com



Data Sheet Revision History

Data Sheet Release: 2014-07-31
Corrected descriptions of pin 19 and 20 in [Details Interface Pin Functions \(Pg. 13\)](#).

Data Sheet Release: 2014-06-27
New Data Sheet for new graphic display modules.

About Variations

We work continuously to improve our products. Because display technologies are quickly evolving, these products may have component or process changes. Slight variations (for example, contrast, color, or intensity) between lots are normal. If you need the highest consistency, whenever possible, order and arrange delivery for your production runs at one time so your displays will be from the same lot.

The Fine Print

Certain applications using CrystalFontz America, Inc. products may involve potential risks of death, personal injury, or severe property or environmental damage ("Critical Applications"). CRYSTALFONTZ AMERICA, INC. PRODUCTS ARE NOT DESIGNED, INTENDED, AUTHORIZED, OR WARRANTED TO BE SUITABLE FOR USE IN LIFE-SUPPORT APPLICATIONS, DEVICES OR SYSTEMS OR OTHER CRITICAL APPLICATIONS. Inclusion of CrystalFontz America, Inc. products in such applications is understood to be fully at the risk of the customer. In order to minimize risks associated with customer applications, adequate design and operating safeguards should be provided by the customer to minimize inherent or procedural hazard. Please contact us if you have any questions concerning potential risk applications.

CrystalFontz America, Inc. assumes no liability for applications assistance, customer product design, software performance, or infringements of patents or services described herein. Nor does CrystalFontz America, Inc. warrant or represent that any license, either express or implied, is granted under any patent right, copyright, or other intellectual property right of CrystalFontz America, Inc. covering or relating to any combination, machine, or process in which our products or services might be or are used.

All specifications in Data Sheets and on our website are, to the best of our knowledge, accurate but not guaranteed. Corrections to specifications are made as any inaccuracies are discovered.

Company and product names mentioned in this publication are trademarks or registered trademarks of their respective owners.

Copyright © 2014 by CrystalFontz America, Inc., 12412 East Saltese Avenue, Spokane Valley, WA 99216-0357 U.S.A



About Volatility

The CrystalFontz CFAG128128I-xxx-VZ of modules has volatile memory.



CONTENTS

MAIN FEATURES	6
Features	6
Explanation Of Part Number Codes In This Data Sheet	7
Comparison Of The Three Colors (Variants)	7
MECHANICAL SPECIFICATIONS	8
Physical Characteristics	8
Module Outline Drawing	9
ELECTRICAL SPECIFICATIONS	10
System Block Diagram	10
Frame Ground	11
LCD Duty And Bias	11
Absolute Maximum Ratings	12
Recommended DC Characteristics	13
Details Interface Pin Functions	13
ESD (Electro-Static Discharge)	14
Typical VO Connections For Display Contrast	14
OPTICAL SPECIFICATIONS	15
Test Conditions And Definitions For Optical Characteristics	16
HALF-HEIGHT CHARACTER RAM INCLUDES ICONS	20
BACKLIGHT SPECIFICATIONS	20
PRODUCT RELIABILITY AND LONGEVITY	23
Module Reliability	23
Module Longevity (EOL / Replacement Policy)	23
CARE AND HANDLING PRECAUTIONS	24
Handling Caution For Modules Shipped In Trays	24
ESD (Electro-Static Discharge)	24
Design and Mounting	24
Avoid Shock, Impact, Torque, or Tension	25
Caution	25
How to Clean	25
Operation	25
Storage and Recycling	26
APPENDIX A: QUALITY ASSURANCE STANDARDS	27
APPENDIX B: RAiO RA6963 CONTROLLER DATA SHEET	30



LIST OF FIGURES

Figure 1. Module Outline Drawing - - - - -	8
Figure 2. System Block Diagram - - - - -	9
Figure 3. Frame Ground (Back View of Module) - - - - -	10
Figure 4. Typical V_O Connections for Display Contrast - - - - -	14
Figure 5. CFAG128128I-TFH-VZ and CFAG128128I-YYH-VZ Operation Voltage (Positive) - - - - -	16
Figure 6. CFAG128128I-TMI-VZ Operation Voltage (Negative)- - - - -	16
Figure 7. CFAG128128I-TFH-VZ And CFAG128128I-YYH-VZ Response Time (Tr, Tf) (Positive)- - - - -	17
Figure 8. CFAG128128I-TMI-VZ Response Time (Tr, Tf) (Negative) - - - - -	17
Figure 9. Definition Of Horizontal And Vertical Viewing Angles (CR>2) - - - - -	18
Figure 10. 6:00 O’Clock And 12:00 O’Clock Viewing Angles - - - - -	18
Figure 11. Typical LED Backlight Connections Using Pin A And Pin K - - - - -	21
Figure 12. Typical LED Backlight Connections For PWM Dimming - - - - -	22



MAIN FEATURES

FEATURES

- These 128 x 128 graphic display modules consist of an LCD panel, a PCB (Printed Circuit Board) with an integrated controller, a segment driver, and an LED backlight.
- Module Dimensions:
 - Active Area is 44.77 (W) x 44.77 (H) millimeters.
 - Overall dimension is 72.5 (W) x 69.9 (H) x 10.20 (D) millimeters.
- Integrated RAiO RA6963 or compatible microcontroller. RAiO RA6963 is compatible with the discontinued Toshiba T6963C. See [APPENDIX B: RAiO RA6963 CONTROLLER DATA SHEET \(Pg. 30\)](#).
- 8080 8-bit parallel
- CFAG128128I-xxx-VZ variants are:
 - *CFAG128128I-TFH-VZ*: White LED backlight with neutral FSTN LCD. Displays dark (near-black) characters on light gray (near-white) background. Positive transfective mode display is sunlight readable and also readable in dark areas.
 - *CFAG128128I-TMI-VZ*: White LED backlight with blue STN LCD. Displays light (near-white) characters on blue background. Negative transmissive mode display can be read in normal office lighting and in dark areas. Not recommended for use in bright sunlight; may be washed out.
 - *CFAG128128I-YYH-VZ*: Yellow-green LED backlight with yellow-green STN LCD. Displays dark (near-black) characters on yellow-green background. Positive transfective mode display is sunlight readable and also readable in dark areas.
- Built-in negative voltage generator.
- 6:00 o'clock viewing angle (polarizer viewing direction).
- Temperature operation is from -20°C to +70°C.
- RoHS and REACH (SVHC) compliant.





EXPLANATION OF PART NUMBER CODES IN THIS DATA SHEET

<u>CFA</u>	<u>G</u>	<u>128</u>	<u>128</u>	<u>I</u>	-	<u>X</u>	<u>X</u>	<u>X</u>	-	<u>V</u>	<u>Z</u>
①	②	③	④	⑤		⑥	⑦	⑧		⑨	⑩

①	Brand	CFA – CrystalFontz America, Incorporated
②	Display Type	G – Graphic
③	Number of Pixels (Width)	128 Pixels
④	Number of Pixels (Height)	128 Pixels
⑤	Model Identifier	I
⑥	Backlight Type & Color	X = T – white LEDs Y – yellow-green LEDs
⑦	Fluid Type, Image (Positive or Negative)	X = F – FSTN, positive, neutral M – STN, negative, blue Y – STN, positive, yellow-green
⑧	Polarizer Film Type and View Angle (O’Clock)¹	X = H – Transflective, 6:00 I – Transmissive, 6:00
¹ For more information on Viewing Angle, see Definition of Horizontal And Vertical Viewing Angles (CR>2) (Pg. 19) .		
⑨	Special Code 1	V – Built-in negative voltage generator (on the PCB)
⑩	Special Code 2	T – LCD driver

COMPARISON OF THE THREE COLORS (VARIANTS)

Part Number	CFAG128128I-TFH-VZ 	CFAG128128I-TMI-VZ 	CFAG128128I-YYH-VZ 
Fluid	FSTN	STN	STN
LCD Glass Color	neutral	blue	yellow-green
Image	positive	negative	positive
Polarizer Film	transflective	transmissive	transflective
LEDs	white		yellow-green
<p><i>Notes</i> FSTN has better contrast than STN.</p> <p>Positive Image = Sunlight readable and also readable in dark areas. Negative Image = Not recommended for use in sunlight; may be washed out.</p>			



MECHANICAL SPECIFICATIONS

PHYSICAL CHARACTERISTICS

ITEM	SPECIFICATION
Pixels	
Number of Pixels	128 x 128 pixels
Pixel Size	Millimeters: 0.320 (W) x 0.320 (H) mm Inches: 0.013" (W) x 0.013"(H)
Pixel Pitch	Millimeters: 0.350 (W) x 0.350 (H) mm Inches: 0.014" (W) x 0.014" (H)
Viewing Area	Millimeters: 50.00 (W) x 49.00 (H) mm Inches: 1.97" (W) x 1.93" (H)
Active Area	
Diagonal	Millimeters: 63.31 mm Inches: 2.49"
Width and Height	Millimeters: 44.77 (W) x 44.77 (H) mm Inches: 1.76" (W) x 1.76" (H)
Module Overall Dimensions	
Width and Height	Millimeters: 65.50 (W) x 71.00 (H) mm Inches: 2.58" (W) x 2.80" (H)
Depth:	Millimeters: 10.20 mm maximum Inches: 0.40"
Weight	CFAG128128I-TFH-VZ: 64 grams CFAG128128I-TMI-VZ: 64 grams CFAG128128I-YYH-VZ: 72 grams



MODULE OUTLINE DRAWING

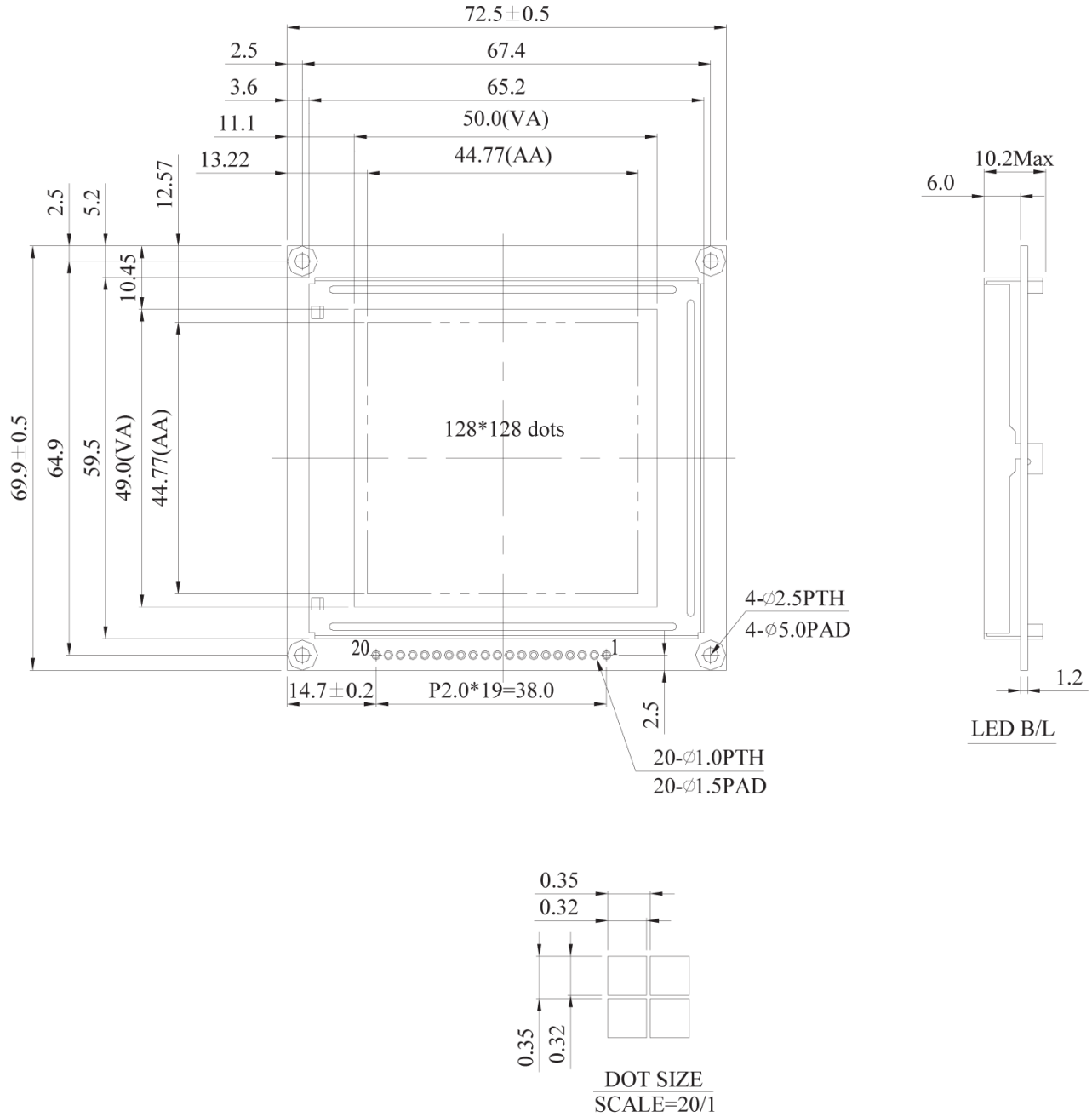
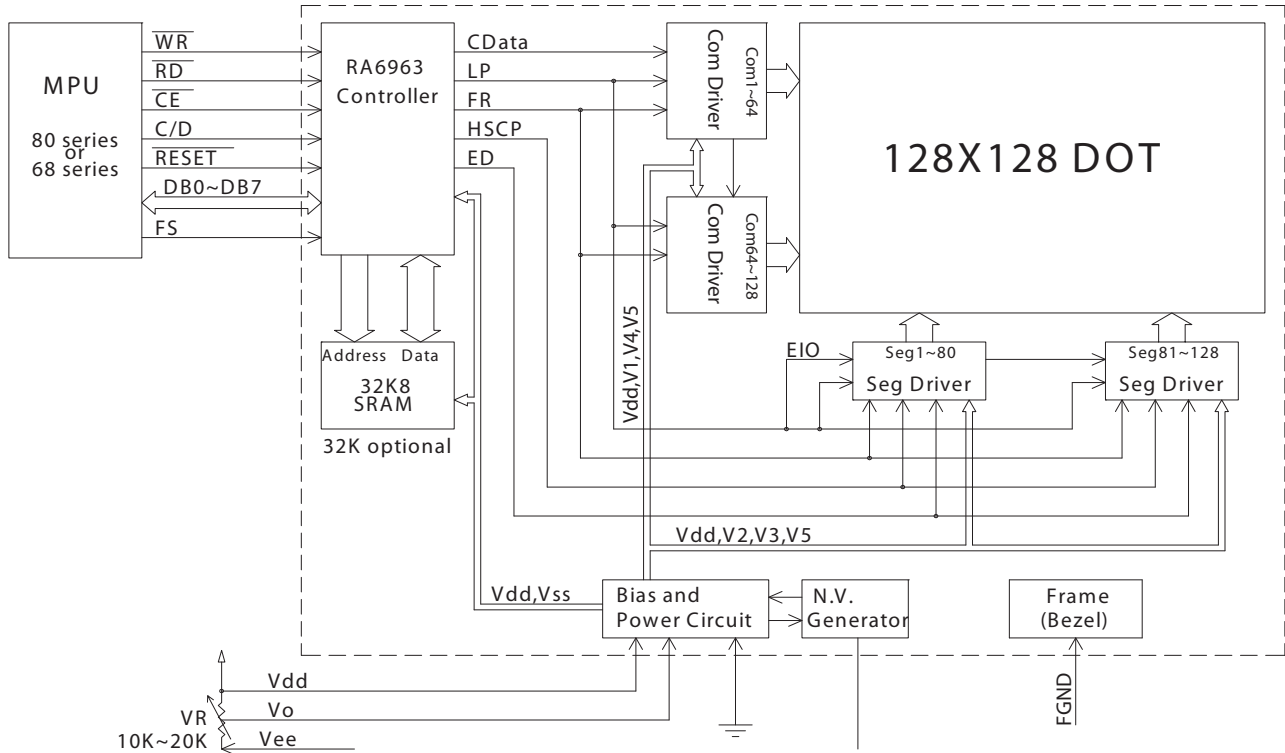

Figure 1. Module Outline Drawing



ELECTRICAL SPECIFICATIONS

SYSTEM BLOCK DIAGRAM



External contrast adjustment.

Figure 2. System Block Diagram



FRAME GROUND

Frame Ground is a trace that connects some of the bezel tabs. To connect Frame Ground to the Logic Ground (GND, Pin 2), use an “0805” package 0 Ω resistor to close jumper JE. In some cases, it may be preferable to use a 1M Ω resistor to close JE.

Resistor JF connects from bezel to frame ground.

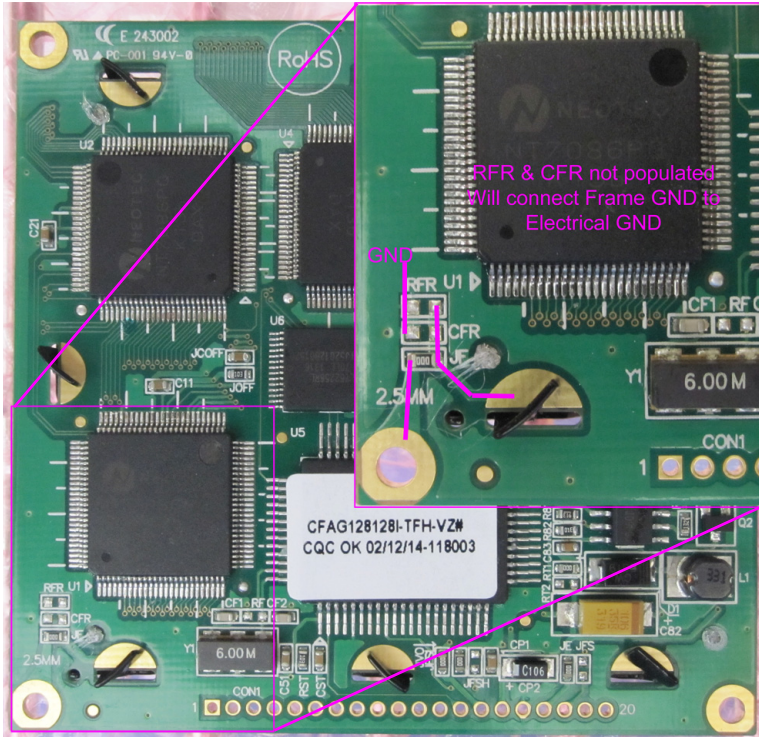

Figure 3. Frame Ground (Back View of Module)

LCD DUTY AND BIAS

DRIVING METHOD	SPECIFICATION
Duty ¹	1/128
Bias ²	1/12

¹The duty cycle, also known as duty ratio or multiplex rate, is the fraction of total frame time that each row of the LCD is addressed.

²The drive bias, also known as voltage margin, is related to the number of voltage levels used when driving the LCD. Bias is defined as 1/(number of voltage levels-1). The more segments driven by each driver(1), the higher number of voltage levels are required. There is a direct relationship between the bias and the duty.



ABSOLUTE MAXIMUM RATINGS

ABSOLUTE MAXIMUM RATINGS	SYMBOL	MINIMUM	MAXIMUM
Operating Temperature	T_{OP}	-20°C	+70°C
Storage Temperature	T_{ST}	-30°C	+80°C
Humidity (Noncondensing)	RH	0%	90%
Input Voltage	V_I	-0.3v	$V_{LOGIC}+0.3v$
Supply Voltage for Logic	$V_{LOGIC}-V_{SS}$	-0.3v	+7v
<p>Caution <i>These are stress ratings only. Extended exposure to the absolute maximum ratings listed above may affect device reliability or cause permanent damage. Functional operation of the module at these conditions beyond those listed under (Pg. 12) is not implied.</i></p> <p><i>Changes in temperature can result in changes in contrast.</i></p>			



RECOMMENDED DC CHARACTERISTICS

	Recommended DC CHARACTERISTICS	TEST CONDITIONS	SYMBOL	MINIMUM	TYPICAL	MAXIMUM
CONTROLLER AND BOARD	Logic Supply Voltage		$V_{\text{LOGIC}} - \text{GND}$	+4.5v	+5.0v	+5.5v
	<i>Note: Please design the V_{OP} adjustment circuit on host's main board. TIM does this note make sense?</i>					
	Input High Voltage		V_{IH}	$0.8v * V_{\text{LOGIC}}$	—	V_{LOGIC}
	Input Low Voltage		V_{IL}	0v (GND)	—	$+0.15v * V_{\text{LOGIC}}$
	Output High Voltage		V_{OH}	$V_{\text{LOGIC}} - 0.3v$	—	V_{LOGIC}
	Output Low Voltage		V_{OL}	0v (GND)	—	+0.3v
	Supply Current Logic only, not including backlight	$V_{\text{LOGIC}} = +5v$	I_{DD}	—	10 mA	—
LCD GLASS	Supply voltage for driving LCD	$T_A = -20^\circ\text{C}$	$V_{\text{LOGIC}} - V_{\text{O}}$	—	—	—
		$T_A = +25^\circ\text{C}$		+15.8v	+16.3v	+16.8v
		$T_A = +70^\circ\text{C}$		—	—	—
<i>This is a summary of the module's major operating parameters. For detailed information see APPENDIX B: RAiO RA6963 CONTROLLER DATA SHEET (Pg. 30).</i>						

DETAILS INTERFACE PIN FUNCTIONS

From front view, pin order from left to right is 20 to 0.

PIN	SIGNAL	LEVEL	DIRECTION	DESCRIPTION
$V_{\text{LOGIC}} = V_{\text{DD}} \quad \text{GND} = V_{\text{SS}}$				
1-8	DB0-DB7	H/L		Databus lines.
9	D/\bar{C}	L		Data/Command control. Determines whether data bits are data or command. 1 – High: Addresses the data register. 0 – Low: Addresses the command register.
10	$\bar{R}\bar{D}$	+5.0v		Data read.
11	$\bar{W}\bar{R}$	+3.0~+5.0v		Data write.
12	$\bar{C}\bar{E}$	L		Chip enables the controller.



PIN	SIGNAL	LEVEL	DIRECTION	DESCRIPTION (Continued)
$V_{\text{LOGIC}} = V_{\text{DD}}$ $GND = V_{\text{SS}}$				
13	$\overline{\text{RST}}$	H/L		Reset signal. <i>Low:</i> Display controller is reset. The $\overline{\text{RST}}$ pin should be pulsed low shortly after power is applied. <i>High:</i> The $\overline{\text{RST}}$ pin should be brought <i>high</i> for normal operation.
14	V_{O}	variable	—	Supply voltage for driving LCD (contrast adjustment). $V_{\text{O}} = -3.0\text{v}$ typical at $V_{\text{LOGIC}} = +5\text{v}$ which gives $V_{\text{LCD}} = (V_{\text{LOGIC}} - V_{\text{O}}) = +8\text{v}$
15	V_{LOGIC}	+5.0v	—	Supply voltage for logic.
16	V_{SS} (GND)	0v	—	Ground. Must be connected to an external ground.
17	V_{EE}	-5.0v	O	Negative voltage output.
18	NC			Make no connection.
19	A1 (LED +)			Common supply pin for LEDs. "A" (anode) or "+" of LED backlight.
20	K (LED -)			Individual supply pins for LED. "K" (cathode or kathode for German and original Greek spelling) or "-" of LED backlight.
For backlight connection, see BACKLIGHT SPECIFICATIONS (Pg. 20) .				

ESD (ELECTRO-STATIC DISCHARGE)

The circuitry is industry standard CMOS logic and susceptible to ESD damage. Please use industry standard antistatic precautions as you would for any other static sensitive devices such as expansion cards, motherboards, or integrated circuits. Ground your body, work surfaces, and equipment.

TYPICAL VO CONNECTIONS FOR DISPLAY CONTRAST

Adjust V_{O} to -3.0v ($V_{\text{LCD}} = +8.0\text{v}$) as an initial setting. When the module is operational, readjust V_{O} for optimal display appearance.

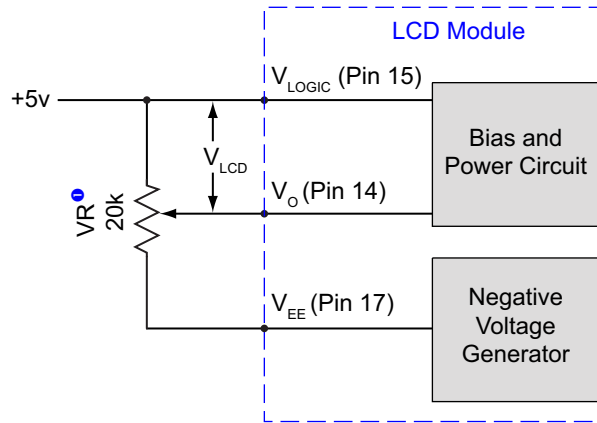

- Use external control to adjust for optimal display appearance.

Figure 4. Typical V_O Connections for Display Contrast

OPTICAL SPECIFICATIONS

CFAG128128I-TFH-VZ



ITEM	SYMBOL	TEST CONDITION	MINIMUM	TYPICAL	MAXIMUM
View Angle (Vertical, Horizontal)	(V) θ	CR \geq 2	+30°	—	+60°
	(H) ϕ	CR \geq 2	-45°	—	+45°
Contrast Ratio ¹	CR	—	—	5	—
LCD Response Time ^{2,3}	T rise	Ta = 25°C		150 ms	200 ms
	T fall	Ta = 25°C		150 ms	200 ms

¹ Contrast Ratio = (brightness with pixels light)/(brightness with pixels dark).
² Response Time: The amount of time it takes a liquid crystal cell to go from active to inactive or back again.
³ For reference only



CFAG128128I-TMI-VZ  and CFAG128128I-YYH-VZ 

ITEM	SYMBOL	TEST CONDITION	MINIMUM	TYPICAL	MAXIMUM
View Angle (Vertical, Horizontal)	(V) θ	CR \geq 2	+20°	—	+40°
	(H) ϕ	CR \geq 2	-30°	—	+30°
Contrast Ratio ¹	CR	—	—	3	—
LCD Response Time ^{2,3}	T rise	Ta = 25°C		150 ms	200 ms
	T fall	Ta = 25°C		150 ms	200 ms

¹ Contrast Ratio = (brightness with pixels light)/(brightness with pixels dark).
² Response Time: The amount of time it takes a liquid crystal cell to go from active to inactive or back again.
³ For reference only

TEST CONDITIONS AND DEFINITIONS FOR OPTICAL CHARACTERISTICS

We work to continuously improve our products, including backlights that are brighter and last longer. Slight color variations from module to module and batch to batch are normal.

Test Conditions

- Operating Voltage (V_{LCD}): V_{OP}
- Viewing Angle
 - Vertical (V) θ : 0°
 - Horizontal (H) ϕ : 0°
- Frame Frequency: 64 Hz (nominal)
- Driving Waveform: 1/28 Duty, 1/12 Bias
- Ambient Temperature (Ta): 25°C



Definition Of Operation Voltage (V_{OP})

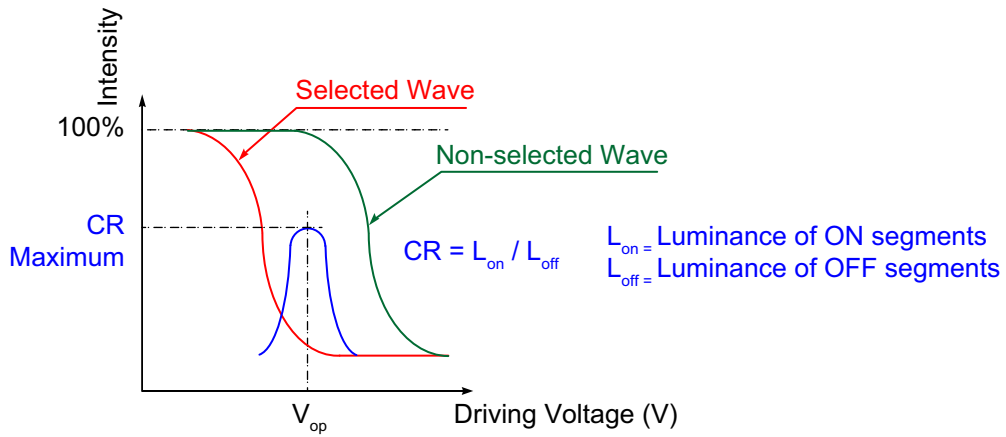

Figure 5. CFAG128128I-TFH-VZ and CFAG128128I-YYH-VZ Operation Voltage (Positive)

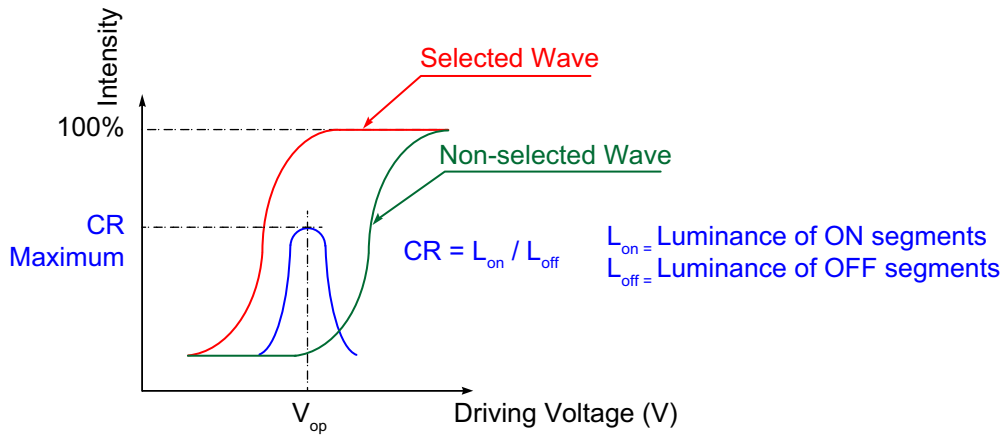

Figure 6. CFAG128128I-TMI-VZ Operation Voltage (Negative)



Definition Of Response Time (T_r , T_f)

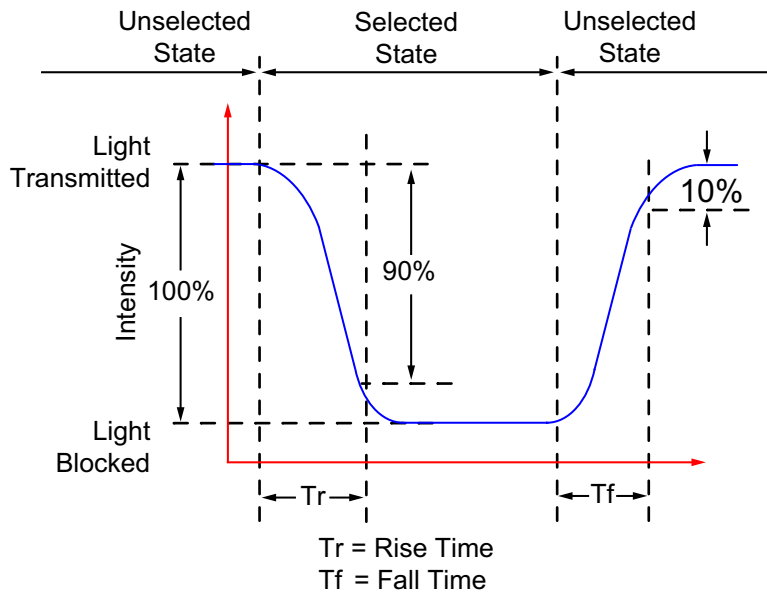

Figure 7. CFAG128128I-TFH-VZ And CFAG128128I-YYH-VZ Response Time (T_r , T_f) (Positive)

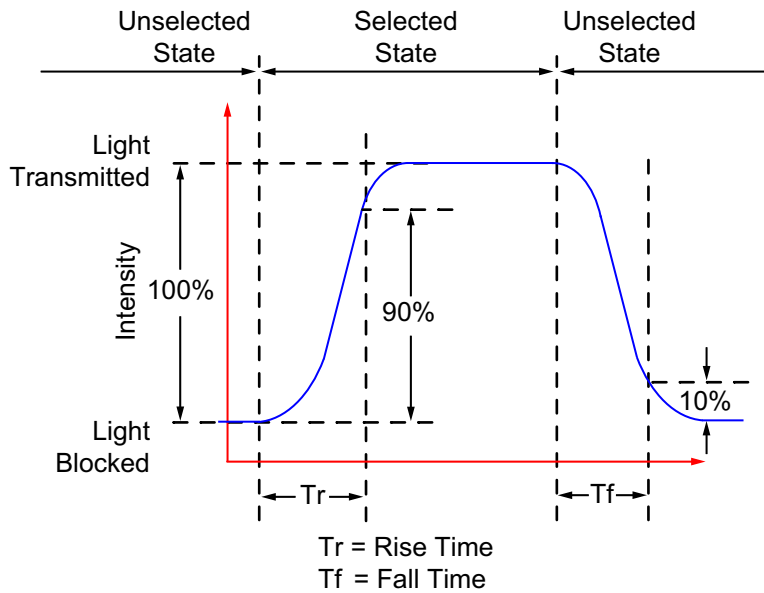

Figure 8. CFAG128128I-TMI-VZ Response Time (T_r , T_f) (Negative)



Definition of Horizontal And Vertical Viewing Angles (CR>2)

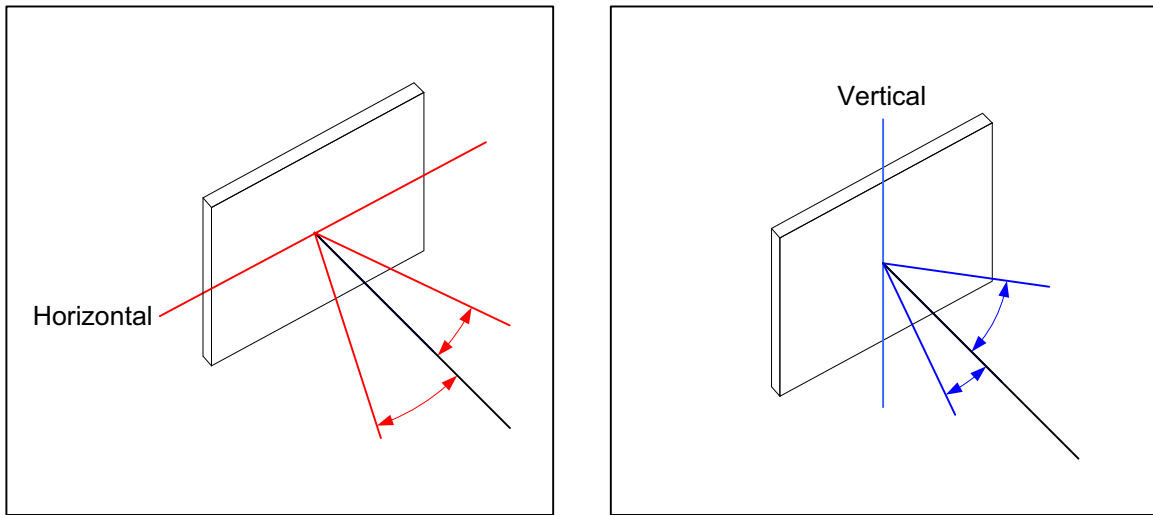

Figure 9. Definition Of Horizontal And Vertical Viewing Angles (CR>2)

Definition of 6:00 O'clock And 12:00 O'clock Viewing Angles

These modules have a 6:00 o'clock viewing angle.

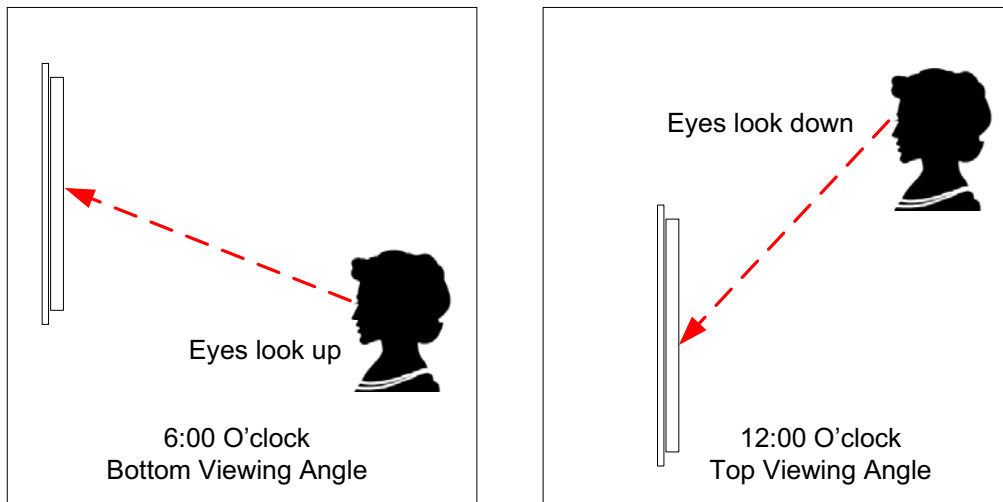

Figure 10. 6:00 O'Clock And 12:00 O'Clock Viewing Angles



HALF-HEIGHT CHARACTER RAM INCLUDES ICONS

CGROM Font – 01

LSB	0	1	2	3	4	5	6	7	8	9	A	B	C	D	E	F	
MSB		!	"	#	\$	%	&	'	()	*	+	,	-	.	/	
0		0	1	2	3	4	5	6	7	8	9	:	;	<	=	>	?
1		a	b	c	d	e	f	g	h	i	j	k	l	m	n	o	
2		p	q	r	s	t	u	v	w	x	y	z	[\]	^	_
3		`	a	b	c	d	e	f	g	h	i	j	k	l	m	n	o
4		p	q	r	s	t	u	v	w	x	y	z	{		}	~	
5		0	1	2	3	4	5	6	7	8	9	:	;	<	=	>	?
6		a	b	c	d	e	f	g	h	i	j	k	l	m	n	o	
7		p	q	r	s	t	u	v	w	x	y	z	[\]	^	_

BACKLIGHT SPECIFICATIONS

CFAG128128I-TFH-VZ and CFAG128128I-TMI-VZ White LED Backlight Characteristics					
ITEM	SYMBOL	TEST CONDITION	MINIMUM	TYPICAL	MAXIMUM
Forward Current	I_{LED}	$V = +3.5v$	—	64 mA	80 mA*
*Driving the backlight above 80 mA will shorten its lifetime.					
Forward Voltage	V_{LED}	—	+3.4v	+3.5v	+3.6v
Reverse Voltage	V_R	—	—	—	+5.0v



CFAG128128I-YYH-VZ Yellow-Green LED Backlight Characteristics					
ITEM	SYMBOL	TEST CONDITION	MINIMUM	TYPICAL	MAXIMUM
Forward Current	I_{LED}	$V = +4.1v$	252 mA	280 mA	336 mA*
<i>*Driving the backlight above 280 mA will shorten its lifetime.</i>					
Forward Voltage	V_{LED}	—	+3.9	+4.1v	+4.3v
Reverse Voltage	V_R	—	—	—	+8.0v

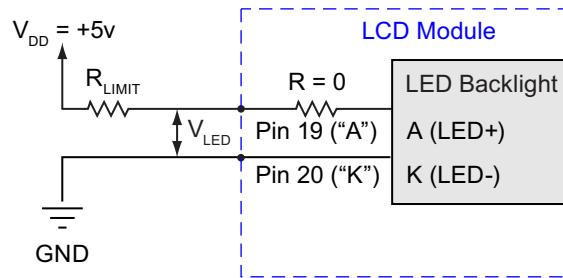

The CFAG128128I-xxx-VZ backlights use LEDs. The backlight is easy to use properly but it is also easily damaged by abuse.

Note
 Do not connect +5v directly to the backlight terminals. This will ruin the backlight.

LEDs are “current” devices. The brightness is controlled by the current flowing through it, not the voltage across it. Ideally,

Note for CFAG128128I-TMI-VZ and CFAG128128I-TFH-VZ
 We recommend that the white LED backlight be dimmed or turned off during periods of inactivity to conserve the LEDs’ lifetime.

a current source would be used to drive the LEDs. In practice, a simple current limiting resistor will work well in most applications and is much less complex than a current source.



How To Calculate The Value Of R_{LIMIT}

You need to know what the supply (forward) voltage of the LEDs will be so you can calculate the value of the current limiting resistor (R_{LIMIT}). The forward voltage will vary slightly from display to display.

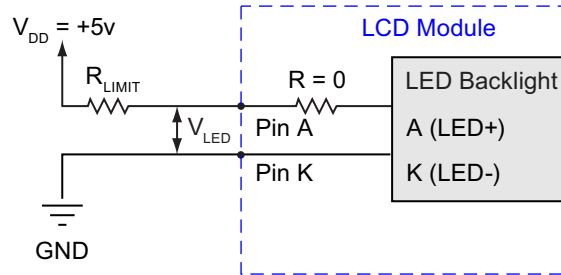

Figure 11. Typical LED Backlight Connections Using Pin A And Pin K

The general equation to calculate each R_{LIMIT} is:

$$R_{LIMIT} \text{ (minimum)} = \frac{V_{DD} \text{ (Supply Voltage)} - V_{LED} \text{ (Typical LED Forward Voltage)}}{I_{LED} \text{ (Typical LED Forward Current)}}$$

The specific R_{LIMIT} calculation for the *CFAG128128I-TFH-VZ* and *CFAG128128I-TMI-VZ* at $V_{DD} = +5v$ is:

$$R_{LIMIT} = \frac{5v - 3.5v}{0.064 \text{ A}} = 23 \Omega \text{ (minimum – use next larger standard size)}$$

The specific R_{LIMIT} calculation for the *CFAG128128I-YYH-VZ* at $V_{DD} = +5v$ is:

$$R_{LIMIT} = \frac{5v - 4.1v}{0.28 \text{ A}} = 3.2 \Omega \text{ (minimum – use next larger standard size)}$$

How To Calculate The Power Rating Of The Resistor

The general equation to calculate the power rating of the resistor is:

$$P = IE$$

where

P= Power. Measured in Watts (W).

I= Current. Measured in amperes (A). “I” is from the outdated term “Intensity”.

E= Voltage. Measured in volts (v). “E” is from the outdated term “Electromotive force”.

The specific power rating calculation for *CFAG128128I-TFH-VZ* and *CFAG128128I-TMI-VZ* is:

$$P = 0.064 \text{ A} \times (5.0v - 3.5v) = 0.096W$$

We recommend a minimum of *1/4 Watt resistor*.

The specific power rating calculation for *CFAG128128I-YYH-VZ* is:

$$P = 0.28 \text{ A} \times (5.0v - 4.1v) = 0.252W$$

We recommend a minimum of *1/2 Watt resistor*.



PWM Dimming

The backlight may be dimmed by PWM (Pulse Width Modulation). The typical range for the PWM frequency is from 100 to 300 Hz.

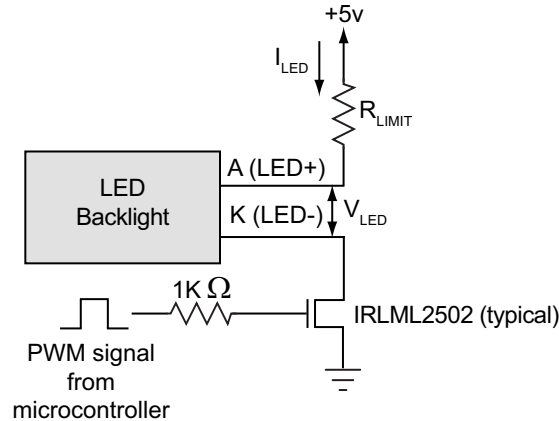

Figure 12. Typical LED Backlight Connections For PWM Dimming

PRODUCT RELIABILITY AND LONGEVITY

MODULE RELIABILITY

ITEM	SPECIFICATION	
Module, excluding backlight.	50,000 to 100,000 hours (typical)	
White LED Backlight ($I_{LED} \leq 280$ mA)	Power-On Hours	% of Initial Brightness
	<10,000	>70%
	<50,000	>50%
Yellow-green LED Backlight ($I_{LED} \leq 64$ mA)	50,000 to 100,000 hours (typical)	
<p><i>Under operating and storage temperature specification limitations, humidity (noncondensing) RH up to 60%, and no exposure to direct sunlight. Values listed above are approximate and represent typical lifetime.</i></p> <p><i>The white LEDs dim over time, especially if driven with high currents. The dimming may not be noticeable when a single display is installed. However, if a new display is installed next to a display that has been on continuously for a very long time, you will see the difference. To preserve the lifetime of white LEDs, we recommend that white LED backlights are dimmed or turned off when not needed. Also, please do not use more current than you need to achieve your brightness requirements.</i></p>		

MODULE LONGEVITY (EOL / REPLACEMENT POLICY)

Crystalfontz is committed to making all of our LCD modules available for as long as possible. Occasionally, a supplier discontinues a component, or a process used to make the module becomes obsolete, or the process moves to a more modern manufacturing line. In order to continue making the module, we will do our best to find an acceptable replacement part or process which will make the “replacement” fit, form, and function compatible with its predecessor.



We recognize that discontinuing a module may cause problems for some customers. However, rapidly changing technologies, component availability, or low customer order levels may force us to discontinue (“End of Life”, EOL) a module. For example, we must occasionally discontinue a module when a supplier discontinues a component or a manufacturing process becomes obsolete. When we discontinue a module, we will do our best to find an acceptable replacement module with the same fit, form, and function.

In most situations, you will not notice a difference when comparing a “fit, form, and function” replacement module to the discontinued module it replaces. However, sometimes a change in component or process for the replacement module results in a slight variation, perhaps an improvement, over the previous design.

Although the replacement module is still within the stated Data Sheet specifications and tolerances of the discontinued module, changes may require modification to your circuit and/or firmware. Possible changes include:

- *Backlight LEDs.* Brightness may be affected (perhaps the new LEDs have better efficiency) or the current they draw may change (new LEDs may have a different VF).
- *Controller.* A new controller may require minor changes in your code.
- *Component tolerances.* Module components have manufacturing tolerances. In extreme cases, the tolerance stack can change the visual or operating characteristics.

Please understand that we avoid changing a module whenever possible; we only discontinue a module if we have no other option. We publish Part Change Notices (PCN) as soon as possible.

CARE AND HANDLING PRECAUTIONS

For optimum operation of the module and to prolong its life, please follow the precautions below. Excessive voltage will shorten the life of the module. You must drive the display within the specified voltage limit. See [Absolute Maximum Ratings \(Pg. 12\)](#)

HANDLING CAUTION FOR MODULES SHIPPED IN TRAYS

If you receive modules packed in trays, handle trays carefully by supporting the entire tray. Trays were made to immobilize the modules inside their packing carton. Trays are not designed to be rigid. Do not carry trays by their edges; trays and modules may be damaged.

ESD (ELECTRO-STATIC DISCHARGE)

The circuitry is industry standard CMOS logic and susceptible to ESD damage. Please use industry standard antistatic precautions as you would for any other static sensitive devices such as expansion cards, motherboards, or integrated circuits. Ground your body, work surfaces, and equipment.

DESIGN AND MOUNTING

- The exposed surface of the “glass” is actually a polarizer laminated on top of the glass. To protect the soft plastic polarizer from damage, the module ships with a protective film over the polarizer. Please peel off the protective film slowly. Peeling off the protective film abruptly may generate static electricity.
- The polarizer is made out of soft plastic and is easily scratched or damaged. When handling the module, avoid touching the polarizer. Finger oils are difficult to remove.



- To protect the soft plastic polarizer from damage, place a transparent plate (for example, acrylic, polycarbonate, or glass) in front of the module, leaving a small gap between the plate and the display surface. We use HP-92 Lexan, which is readily available and works well.
- To protect the polarizer from damage, the module ships with a protective film over the polarizer. Please peel off the protective film slowly. Peeling off the protective film abruptly may generate static electricity.
- Do not disassemble or modify the module.
- Solder only to the I/O terminals. Use care when removing solder so you do not damage the PCB.
- Use care to keep the exposed terminals clean.
- Do not reverse polarity to the power supply connections. Reversing polarity will immediately ruin the module.
- Use care to keep the exposed terminals clean.

AVOID SHOCK, IMPACT, TORQUE, OR TENSION

- Do not expose the module to strong mechanical shock, impact, torque, or tension.
- Do not drop, toss, bend, or twist the module.
- Do not place weight or pressure on the module.

CAUTION

All electronics may contain harmful substances. Avoid contamination by using care to avoid damage during handling. If any residues, gases, powders, liquids, or broken fragments come in contact with your skin, eyes, mouth, or lungs, immediately contact your local poison control or emergency medical center.

HOW TO CLEAN

1. Turn display off.
2. Use the removable protective film to remove smudges (for example, fingerprints) and any foreign matter. If you no longer have the protective film, use standard transparent office tape (for example, Scotch® brand “Crystal Clear Tape”).
3. If the polarizer is dusty, you may carefully blow it off with clean, dry, oil-free compressed air.
4. If you must clean with a liquid, never use glass cleaners, as they may contain ammonia or alcohol that will damage the polarizer over time. Never apply liquids directly on the polarizer. Long contact with moisture may permanently spot or stain the polarizer. Use filtered water to slightly moisten a clean lint-free microfiber cloth designed for cleaning optics. (For example, use a cloth sold for cleaning plastic eyeglasses.)
5. The plastic is easily scratched or damaged. Use a light touch as you clean the polarizer. Wipe gently.
6. Use a dry microfiber cloth to remove any trace of moisture before turning on the TFT.
7. Gently wash the microfiber cloths in warm, soapy water and air dry before reuse.

OPERATION

- We do not recommend connecting this module to a PC's parallel port as an “end product.” This module is not “user friendly” and connecting it to a PC's parallel port is often difficult, frustrating, and can result in a “dead” display due to mishandling. For more information, see our forum thread at <http://www.crystalfontz.com/forum/showthread.php?s=&threadid=3257>.
- Your circuit should be designed to protect the module from ESD and power supply transients.
- Observe the operating temperature limitations. Operation outside of these limits may shorten life and/or harm display. Changes in temperature can result in changes in contrast.
 - At lower temperatures of this range, response time is delayed.
 - At higher temperatures of this range, display becomes dark. (You may need to adjust the contrast.)
- Operate away from dust, moisture, and direct sunlight.



- For the CFAG128128I-TFH-VZ and CFAG128128I-TMI-VZ with white LEDs, adjust backlight brightness so the display is readable but not too bright. Dim or turn off the backlight during periods of inactivity to conserve the white LED backlight lifetime.

STORAGE AND RECYCLING

- Store in an ESD-approved container away from dust, moisture, and direct sunlight, fluorescent lamps, or any ultraviolet ray with humidity less than 90% noncondensing.
- Observe the storage temperature limitations. Rapid temperature changes can cause moisture to form, resulting in permanent damage.
- Do not allow weight to be placed on the modules while they are in storage.
- Please recycle your outdated modules at an approved facility.



APPENDIX A: QUALITY ASSURANCE STANDARDS

INSPECTION CONDITIONS

- Environment
 - Temperature: 25±5°C
 - Humidity: 30~85% RH (noncondensing)
- For visual inspection of active display area
 - Source lighting: two 20-Watt or one 40-Watt fluorescent light
 - Display adjusted for best contrast
 - Viewing distance: 30±5 cm (about 12 inches)
 - Viewing angle: inspect at 45° angle of vertical line right and left, top and bottom

COLOR DEFINITIONS

We try to describe the appearance of our LCD modules as accurately as possible. For the photos, we adjust the backlight (if any) and contrast for optimal appearance. Actual display appearance may vary due to (1) different operating conditions, (2) small variations of component tolerances, (3) inaccuracies of our camera, (4) color interpretation of the photos on your monitor, and/or (5) personal differences in the perception of color.

ACCEPTANCE SAMPLING

DEFECT TYPE	AQL*
Major	≤.65%
Minor	<1.0%
* Acceptable Quality Level: maximum allowable error rate or variation from standard	

DEFECTS CLASSIFICATION

Defects are defined as:

- Major Defect: results in failure or substantially reduces usability of unit for its intended purpose
- Minor Defect: deviates from standards but is not likely to reduce usability for its intended purpose

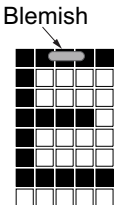
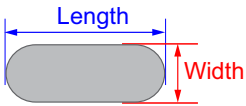
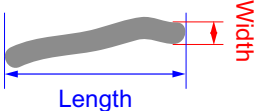

ACCEPTANCE STANDARDS

#	DEFECT TYPE	ACCEPTANCE STANDARDS CRITERIA			MAJOR / MINOR	
1	Electrical defects	1. No display, display malfunctions, or shorted segments. 2. Current consumption exceeds specifications.			Major	
2	Viewing area defect	Viewing area does not meet specifications.			Major	
3	Contrast adjustment defect	Contrast adjustment fails or malfunctions.			Major	
4	Blemishes or foreign matter on display segments		<i>Defect Size</i>	<i>Acceptable Qty</i>	Minor	
			≤0.30 mm	3		
			≤2 defects within 10 mm of each other			
5	Blemishes or foreign matter outside of display segments	Defect Size = (Width + Length)/2 	<i>Defect Size</i>	<i>Acceptable Qty</i>	Minor	
			≤0.15 mm	Ignore		
			0.15 to 0.20 mm	3		
			0.20 to 0.25 mm	2		
			> 0.30 mm	1		
6	Dark lines or scratches in display area		<i>Defect Width</i>	<i>Defect Length</i>	<i>Acceptable Qty</i>	Minor
			≤0.03 mm	≤3.0 mm	3	
			0.03 to 0.05	≤2.0 mm	2	
			0.05 to 0.08	≤2.0 mm	1	
			0.08 to 0.10	≤3.0 mm	0	
			≥0.10	>3.0 mm	0	
7	Bubbles between polarizer film and glass		<i>Defect Size</i>	<i>Acceptable Qty</i>	Minor	
			≤0.20 mm	Ignore		
			0.20 to 0.40 mm	3		
			0.40 to 0.60 mm	2		
			≥0.60 mm	0		



#	DEFECT TYPE	ACCEPTANCE STANDARDS CRITERIA (Continued)	MAJOR / MINOR								
8	Display pattern defect		Minor								
		<table border="1"> <thead> <tr> <th>Dot Size</th> <th>Acceptable Qty</th> </tr> </thead> <tbody> <tr> <td>$((A+B)/2) \leq 0.20 \text{ mm}$</td> <td rowspan="5"> ≤ 3 total defects ≤ 2 pinholes per digit </td> </tr> <tr> <td>$C > 0 \text{ mm}$</td> </tr> <tr> <td>$((D+E)/2) \leq 0.25 \text{ mm}$</td> </tr> <tr> <td>$((F+G)/2) \leq 0.25 \text{ mm}$</td> </tr> <tr> <td></td> </tr> </tbody> </table>		Dot Size	Acceptable Qty	$((A+B)/2) \leq 0.20 \text{ mm}$	≤ 3 total defects ≤ 2 pinholes per digit	$C > 0 \text{ mm}$	$((D+E)/2) \leq 0.25 \text{ mm}$	$((F+G)/2) \leq 0.25 \text{ mm}$	
		Dot Size		Acceptable Qty							
		$((A+B)/2) \leq 0.20 \text{ mm}$		≤ 3 total defects ≤ 2 pinholes per digit							
		$C > 0 \text{ mm}$									
$((D+E)/2) \leq 0.25 \text{ mm}$											
$((F+G)/2) \leq 0.25 \text{ mm}$											
9	Backlight defects	<ol style="list-style-type: none"> 1. Light fails or flickers.* 2. Color and luminance do not correspond to specifications.* 3. Exceeds standards for display's blemishes, foreign matter, dark lines or scratches. <p>*Minor if display functions correctly. Major if the display fails.</p>	Minor								
10	PCB defects (if module has PCB)	<ol style="list-style-type: none"> 1. Oxidation or contamination on connectors.* 2. Wrong parts, missing parts, or parts not in specification.* 3. Jumpers set incorrectly. 4. Solder (if any) on bezel, LED pad, zebra pad, or screw hole pad is not smooth. <p>*Minor if display functions correctly. Major if the display fails.</p>	Minor								
11	Soldering defects	<ol style="list-style-type: none"> 1. Unmelted solder paste. 2. Cold solder joints, missing solder connections, or oxidation.* 3. Solder bridges causing short circuits.* 4. Solder balls. <p>*Minor if display functions correctly. Major if the display fails.</p>	Minor								



APPENDIX B: RAI0 RA6963 CONTROLLER DATA SHEET

The complete *RAiO RA6963 Data Sheet* version 1.8 (42 pages) publication date April 26, 2012 follows.

RAiO

RA6963

Dot Matrix

LCD Controller

Specification

Version 1.8

April 26, 2012

RAiO Technology Inc.

©Copyright RAiO Technology Inc. 2011, 2012

Update History		
Version	Date	Description
1.0	May 29, 2007	Formal Release
1.1	September 27, 2007	Update Figure 9-4
1.2	November 15, 2007	Update < Table 8-2 > Max. f_{OSC} to 18MHz. Update < Table 8-4 > Max. f_{SCP} to 9MHz. Update the Chapter 5-4 "Misc Interface" – the description of pin "MDS" and MD[1:0].
1.3	February 26, 2008	Update the description of pin "X1" in Section 5-4. Update Figure 6-13, 6-14, 9-5 and 9-6.
1.4	March 27, 2009	Update < Table 6-5 > Command Definition Description. Update Figure 6-10. Update < Table 6-31 > Package Description in Section 6-21. Update < Table 8-2 >
1.5	July 07, 2009	Update Figure 9-6
1.6	March 02, 2010	Update the Section 7-1 : Die Form
1.7	January 20, 2011	Update <Table 5-4> : delete the description of FONTSEL Update <Table 6-1> : the description of CDATA Update <Table 6-15> Delete Section 6-16 : Screen Reverse Delete Section 6-17 : Blink Time Delete Section 6-18 : Cursor Auto Moving Delete Section 6-19 : CGROM Font Select Delete Section 6-21 : RA6963 vs T6963C Delete Section 7-1 : Die Form Delete Section 7-2 : Part Number Delete Section 7-3 : XY Coordinate
	May 5, 2011	Modify feature description - 256 word ROM -> 128 word ROM Delete feature description – Bold and Display reverse
1.8	April 26, 2012	Modify Ch5: Pin Description Modify <Table 8-2>

Chapter	Contents	Pages
1.	Overview	5
2.	Features	5
3.	Block Diagram	5
4.	Package	6
5.	Pin Descriptions.....	6
	5-1 MPU Interface	6
	5-2 LCD Driver Interface	7
	5-3 Memory Interface	7
	5-4 Misc. Interface	8
6.	Functions Description	10
	6-1 Functional Definition	10
	6-2 State After RESET/HALT	10
	6-3 Row / Column and Oscillation Clock.....	11
	6-4 RAM Interface	12
	6-5 Communications with MPU.....	13
	6-5-1 Status Read.....	13
	6-5-2 Setting Data.....	15
	6-5-3 Command Definitions	16
	6-6 Setting Registers.....	17
	6-6-1 Set Cursor Pointer.....	17
	6-6-2 Set Offset Register	18
	6-6-3 Set Address Pointer	19
	6-7 Set Control Word.....	20
	6-7-1 Set Text Home Address	20
	6-7-2 Set Graphic Home Address.....	21
	6-7-3 Set Text Area.....	22
	6-7-4 Set Graphic Area	23
	6-8 Mode Set	24
	6-9 Display Mode	25
	6-10 Cursor Pattern Select	26
	6-11 Data Auto Read/Write	26
	6-12 Data Read/Write.....	28
	6-13 Screen Peek.....	29
	6-14 Screen Copy	30
	6-15 Bit Set/Reset.....	31
	6-16 Character Font Map	32
7.	Package Dimensions	33
	7-1 Outline Drawing	33

8. Specifications	34
8-1 Absolute Maximum Ratings	34
8-2 MPU Interface Timing	35
8-3 Driver Interface Timing	35
8-4 External Memory Interface	36
9. Application	38
9-1 MPU Memory Address Mapping	38
9-2 MPU I/O Addressing.....	39
9-3 Use PPI LSI	39
9-4 Application Block Diagram	40
9-5 Application Circuit(1).....	41
9-6 Application Circuit(2).....	41

1. Overview

The RA6963 is a dot matrix LCD Controller which fully compatible with T6963C. It supports various LCD Driver for standard or custom-made LCD module. The RA6963 built-in a 128-word CG(Character Generator) ROM that for ASCII, Japanese or numeric display in text mode. It also supports Graphics mode and mixed display with Text. The supported maximum external display RAM is 64Kbyte and the display Window can be moved freely within the allocated memory range. The RA6963 has an 8-bit parallel data bus that can be directly connected to an 8080 series MPU.

The RA6963 supports a very broad range of LCD formats by allowing selection of different combinations via a set and combination text-and-graphic modes, and includes various attribute functions.

2. Features

- ◆ Support Display Range:
Columns → 32, 40, 64, 80
Rows → 2, 4, 6, 8, 10, 12, 14, 16, 20, 24, 28, 32
- ◆ Support 8080 8-bit MPU Interface
- ◆ Built-in 128-word Font ROM: Basic ASCII、
Japanese、Numeric
- ◆ Support Max. 64Kbyte External Display SRAM
- ◆ Display Mode : Character、Graphics and Mixed Mode
- ◆ Font Size :
Horizontal → 5, 6, 7, 8 Pixels
Vertical → 8 Pixels
- ◆ Support Various LCD Driver
- ◆ Support 1/16 ~1/128 Duty
- ◆ Built-in X'tal Oscillator or Using External Clock
- ◆ Power Supply Range: 3.0~5.5V
- ◆ Package: LQFP-67Pin (RoHS Compliance)

3. Block Diagram

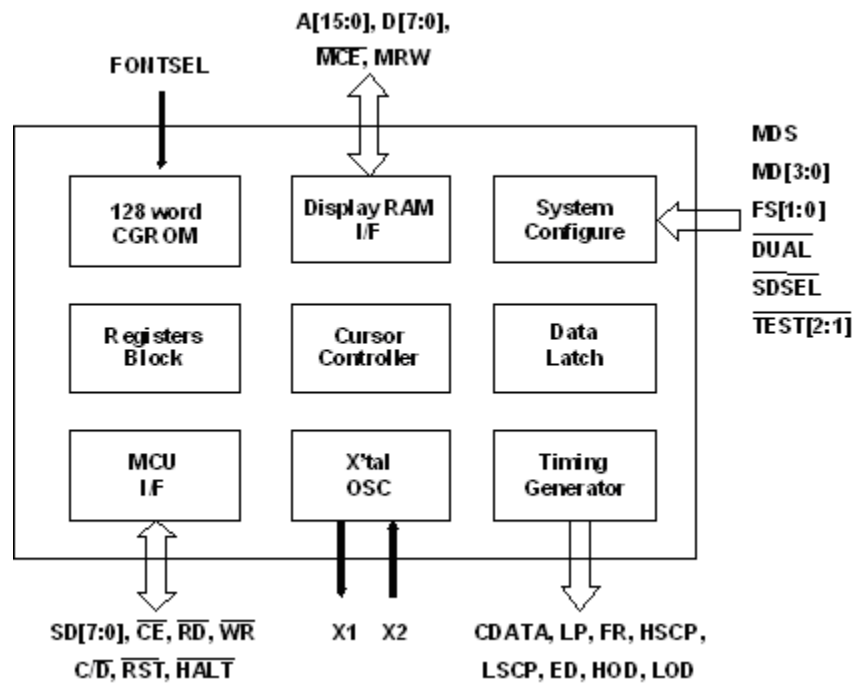

< Figure 3-1 >

4. Package

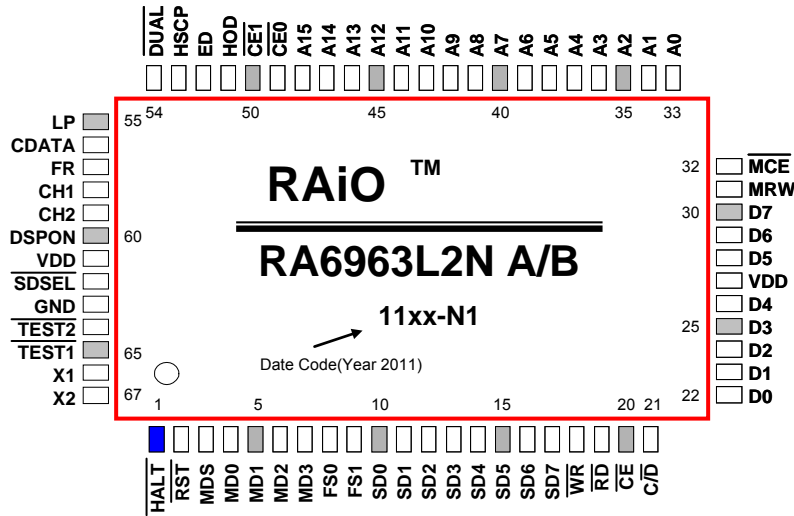

< Figure 4-1 >

RA6963L2NA : LQFP-67 Pin, RoHS Compliance Package, Font-01 (Refer to Chapter 6-16)
RA6963L2NB : LQFP-67 Pin, RoHS Compliance Package, Font-02 (Refer to Chapter 6-16)

5. Pin Descriptions

Item	Symbol	Description
INPUT	I	Input pin.
OUTPUT	O	Output pin, set to high impedance while in-active.
Bi-direction	B	This is bi-directional data bus. While in-active, data bus is set to high impedance.

5-1 MPU Interface

< Table 5-1 >

Pin Name	I/O	Description
SD[7..0]	B	Data Bus This is bus for data transfer between MPU and RA6963.
\overline{RD}	I	Read Control \overline{RD} is a data read signal. When Low, MPU read data from RA6963.
\overline{WR}	I	Write Control \overline{WR} is a data write signal. When Low, MPU write data into RA6963.

C/\overline{D}	I	Command/Data Select or Register Select This is a Data or Command select signal.									
		<table border="1"> <tr> <td>C/\overline{D}</td> <td>$\overline{WR} = \text{Low}$</td> <td>$\overline{RD} = \text{Low}$</td> </tr> <tr> <td>High</td> <td>Command Write</td> <td>Status Read</td> </tr> <tr> <td>Low</td> <td>Data Write</td> <td>Data Read</td> </tr> </table>	C/\overline{D}	$\overline{WR} = \text{Low}$	$\overline{RD} = \text{Low}$	High	Command Write	Status Read	Low	Data Write	Data Read
		C/\overline{D}	$\overline{WR} = \text{Low}$	$\overline{RD} = \text{Low}$							
High	Command Write	Status Read									
Low	Data Write	Data Read									
\overline{CE}	I	Chip Enable This is chip enable of RA6963. When MPU communicate with RA6963, this pin must be Low.									

5-2 LCD Driver Interface

< Table 5-2 >

Pin Name	I/O	Description
FR	O	Frame
LP	O	Latch Latch pulse for column driver. Shift clock pulse for Row Driver
CDATA	O	Synchronous Data Synchronous Data for Row Driver.
HSCP	O	Shift Clock Pulse Shift clock pulse for Column Driver in upper area of LCD.
HOD	O	Data Output Data output for Odd Columns in upper area of LCD.
ED	O	Data Output $\overline{SDSEL} = \text{High} \rightarrow$ Data output for even columns in both upper and lower area of LCD. $\overline{SDSEL} = \text{Low} \rightarrow$ Data output for columns in both upper and lower area of LCD.
DSPON	O	Display On Display On/Off control signal. When \overline{HALT} or \overline{RST} is Low, DSPON output Low (LCD Display Off).

5-3 Memory Interface

< Table 5-3 >

Pin Name	I/O	Description
A[15:0]	O	Address Output for External Memory
D[7:0]	B	Data Bus for External Memory
\overline{MCE}	O	Memory Chip Enable $\overline{MCE} = \text{Low} \rightarrow$ Memory Enable. $\overline{MCE} = \text{High} \rightarrow$ Memory Disable.
MRW	O	Memory Read/Write Control $\overline{MRW} = \text{Low} \rightarrow$ Memory Write Enable. $\overline{MRW} = \text{High} \rightarrow$ Memory Read Enable.

$\overline{\text{CE0}}$ LOD	O	Memory Chip Enable 0 If $\overline{\text{DUAL}} = \text{High}$ → Chip enable pin for display memory in the address range 0000~07FFh. If $\overline{\text{DUAL}} = \text{Low}$ → Serial data output for odd columns in lower area of LCD.
$\overline{\text{CE1}}$ LSCP	O	Memory Chip Enable 1 If $\overline{\text{DUAL}} = \text{High}$ → Chip enable pin for display memory in the address range 0800~0FFFh. If $\overline{\text{DUAL}} = \text{Low}$ → Shift clock output for Column Driver in lower area of LCD.
VDD	P	Power
GND	P	Ground

5-4 Misc. Interface

< Table 5-4 >

Pin Name	I/O	Description																																																																																																												
$\overline{\text{DUAL}}$	I	Scan Select $\overline{\text{DUAL}} = \text{Low}$ → Dual-Scan Mode. $\overline{\text{DUAL}} = \text{High}$ → Signal-Scan Mode.																																																																																																												
MDS MD[1:0]	I	LCD Size Selection One Screen <table border="1" style="margin: 10px auto;"> <tr><td>DUAL</td><td>H</td><td>H</td><td>H</td><td>H</td><td>H</td><td>H</td><td>H</td><td>H</td></tr> <tr><td>MDS</td><td>L</td><td>L</td><td>L</td><td>L</td><td>H</td><td>H</td><td>H</td><td>H</td></tr> <tr><td>MD1</td><td>H</td><td>H</td><td>L</td><td>L</td><td>H</td><td>H</td><td>L</td><td>L</td></tr> <tr><td>MD0</td><td>H</td><td>L</td><td>H</td><td>L</td><td>H</td><td>L</td><td>H</td><td>L</td></tr> <tr><td>Lines</td><td>2</td><td>4</td><td>6</td><td>8</td><td>10</td><td>12</td><td>14</td><td>16</td></tr> <tr><td>V-Dots</td><td>16</td><td>32</td><td>48</td><td>64</td><td>80</td><td>96</td><td>112</td><td>128</td></tr> </table> Two Screens <table border="1" style="margin: 10px auto;"> <tr><td>DUAL</td><td>L</td><td>L</td><td>L</td><td>L</td><td>L</td><td>L</td><td>L</td><td>L</td></tr> <tr><td>MDS</td><td>L</td><td>L</td><td>L</td><td>L</td><td>H</td><td>H</td><td>H</td><td>H</td></tr> <tr><td>MD1</td><td>H</td><td>H</td><td>L</td><td>L</td><td>H</td><td>H</td><td>L</td><td>L</td></tr> <tr><td>MD0</td><td>H</td><td>L</td><td>H</td><td>L</td><td>H</td><td>L</td><td>H</td><td>L</td></tr> <tr><td>Lines</td><td>4</td><td>8</td><td>12</td><td>16</td><td>20</td><td>24</td><td>28</td><td>32</td></tr> <tr><td>V-Dots</td><td>32</td><td>64</td><td>96</td><td>128</td><td>160</td><td>192</td><td>224</td><td>256</td></tr> </table>	DUAL	H	H	H	H	H	H	H	H	MDS	L	L	L	L	H	H	H	H	MD1	H	H	L	L	H	H	L	L	MD0	H	L	H	L	H	L	H	L	Lines	2	4	6	8	10	12	14	16	V-Dots	16	32	48	64	80	96	112	128	DUAL	L	L	L	L	L	L	L	L	MDS	L	L	L	L	H	H	H	H	MD1	H	H	L	L	H	H	L	L	MD0	H	L	H	L	H	L	H	L	Lines	4	8	12	16	20	24	28	32	V-Dots	32	64	96	128	160	192	224	256
DUAL	H	H	H	H	H	H	H	H																																																																																																						
MDS	L	L	L	L	H	H	H	H																																																																																																						
MD1	H	H	L	L	H	H	L	L																																																																																																						
MD0	H	L	H	L	H	L	H	L																																																																																																						
Lines	2	4	6	8	10	12	14	16																																																																																																						
V-Dots	16	32	48	64	80	96	112	128																																																																																																						
DUAL	L	L	L	L	L	L	L	L																																																																																																						
MDS	L	L	L	L	H	H	H	H																																																																																																						
MD1	H	H	L	L	H	H	L	L																																																																																																						
MD0	H	L	H	L	H	L	H	L																																																																																																						
Lines	4	8	12	16	20	24	28	32																																																																																																						
V-Dots	32	64	96	128	160	192	224	256																																																																																																						
X1	I	Crystal Oscillator Input A crystal / ceramic oscillator circuit is built in. The oscillation frequency is adjusted according to the display size. If using an external clock, use the X1 pin as the clock input. (X2 open.) External capacitors 15 to 20pF for Crystal or Ceramic oscillator.																																																																																																												
X2	O	Crystal Oscillator Output																																																																																																												

Pin Name	I/O	Description															
FS[1:0]	I	<p>Font Selection</p> <table border="1"> <tr> <td>FS0</td> <td>H</td> <td>L</td> <td>H</td> <td>L</td> </tr> <tr> <td>FS1</td> <td>H</td> <td>H</td> <td>L</td> <td>L</td> </tr> <tr> <td>Font</td> <td>5 X 8</td> <td>6 X 8</td> <td>7 X 8</td> <td>8 X 8</td> </tr> </table>	FS0	H	L	H	L	FS1	H	H	L	L	Font	5 X 8	6 X 8	7 X 8	8 X 8
FS0	H	L	H	L													
FS1	H	H	L	L													
Font	5 X 8	6 X 8	7 X 8	8 X 8													
MD[3:2]	I	<p>Columns Selection</p> <table border="1"> <tr> <td>MD2</td> <td>H</td> <td>L</td> <td>H</td> <td>L</td> </tr> <tr> <td>MD3</td> <td>H</td> <td>H</td> <td>L</td> <td>L</td> </tr> <tr> <td>Columns</td> <td>32</td> <td>40</td> <td>64</td> <td>80</td> </tr> </table>	MD2	H	L	H	L	MD3	H	H	L	L	Columns	32	40	64	80
MD2	H	L	H	L													
MD3	H	H	L	L													
Columns	32	40	64	80													
$\overline{\text{SDSEL}}$	I	<p>Data Transfer Mode</p> <p>$\overline{\text{SDSEL}}$ = Low → Sending data by simple serial mode. $\overline{\text{SDSEL}}$ = High → Sending data by odd/even separation mode.</p>															
$\overline{\text{HALT}}$	I	<p>Halt Signal</p> <p>$\overline{\text{HALT}}$ = Low → Stop the Clock. $\overline{\text{HALT}}$ = High → Normal Mode.</p>															
$\overline{\text{RST}}$	I	<p>Reset Signal</p> <p>$\overline{\text{RST}}$ = Low → RA6963 will be reset. $\overline{\text{RST}}$ = High → Normal mode. RA6963 built-in a Pull-Hi resistor.</p>															
$\overline{\text{TEST}}[2:1]$	I	<p>Test Pins</p> <p>These are test pins. No need for connection(NC). These two pins have built-in Pull-Hi resistors.</p>															
CH1, CH2	O	Check Signals															

6. Functions Description

6-1 Functional Definition

- ◆ After power on, it is necessary to reset. The $\overline{\text{RST}}$ is kept Low between 5 clocks up (oscillation clock).
- ◆ When $\overline{\text{HALT}}$ = Low, the oscillation stops. The power supply for the LCD must be turned off, to protect the LCD from DC bias.
- ◆ The HALT function($\overline{\text{HALT}}$ = Low) includes the RESET function($\overline{\text{RST}}$ = Low).
- ◆ The column/line counter and display register are cleared by $\overline{\text{RST}}$. (Other registers are not cleared.) Disable the display using the clear-display register
- ◆ The status must be checked before data or commands are sent. The MSB=0 status check must be done in particular. There is a possibility of erroneous operation due to a hard interrupt.
- ◆ STA0 and STA1 must be checked at the same time. When a command is executed, data transmission errors may occur.
- ◆ The RA6963 can only handle one byte per machine cycle (16 clocks). It is impossible to send more than two data in a machine cycle.
- ◆ When using a command with operand data, it important to send the data first, and then executes the command.
- ◆ The character fonts used by the RA6963 are different from ASCII codes.

6-2 State After RESET/HALT

< Table 6-1 >

Pins	HALT	RESET
SD[7:0]	Floating	Floating
D[7:0]	Floating	Floating
MRW	Hi	Hi
MCE	Hi (Note 1)	Hi (Note 1)
A[15:0]	Hi (Note 2)	Hi (Note 2)
$\overline{\text{CE0}}$, $\overline{\text{CE1}}$	Hi (Note 1)	Hi (Note 1)
ED, HOD	Final data	Final data
HSCP	Low	Low
LP	Low	Low
CDATA	Low	Low
FR	Hi	Hi
CH1	Low	Test Signal
CH2	Low	Test Signal
DSPON	Low	Low
X2	Hi	OSC Clock

Note 1 : In Attribute mode, Hi or Low according to state of graphic pointer

Note 2 : In Attribute mode, data to graphic pointer

6-3 Row / Column and Oscillation Clock

The frequency of the crystal oscillator is adjusted by the following formula.

- f_{OSC} : Frequency of oscillation
- f_{SCP} : Frequency of shift clock ($f_{SCP} = f_{OSC} / 2$)
- f_R : Frequency of Frame
- M** : Number of characters on one line (number of dots on one line 8M)
For all font sizes (e.g. 7 x 8, 7 x 8, 5 x 8) the oscillation frequency remains constant.
- N** : Number of rows (Duty=1/8N)

$$\frac{8M}{f_{SCP}} \times 8N = \frac{1}{f_R}$$

$$f_{OSC} = f_R \times 64 \times 2 \times M \times N$$

($f_R = 60\text{Hz}$)

< Table 6-2 >

Unit: MHz

N \ M					Duty	
	32	40	64	80		
2	Upper	0.492	0.614	0.983	1.229	1/16
	Lower	0.983	1.229	1.966	2.458	
4	Upper	0.983	1.229	1.966	2.458	1/32
	Lower	1.966	2.458	3.932	4.915	
6	Upper	1.475	1.843	2.949	3.688	1/48
	Lower	2.949	3.685	5.898	7.372	
8	Upper	1.966	2.458	3.932	4.915	1/64
	Lower	3.932	4.915	7.864	9.830	
10	Upper	2.458	3.072	4.915	6.144	1/80
	Lower	4.915	6.144	9.830	12.288	
12	Upper	2.949	3.686	5.898	7.373	1/96
	Lower	5.898	7.373	11.776	14.746	
14	Upper	3.440	4.300	6.881	8.602	1/112
	Lower	6.881	8.601	13.763	17.203	
16	Upper	3.932	4.915	7.864	9.830	1/128
	Lower	7.864	9.830	15.729	19.660	

Note 1: Upper → Single-Scan. Lower → Dual-Scan at $f_R = 60\text{Hz}$

6-4 RAM Interface

The external RAM is used to store display data (text, graphic and external CG data).

With single-scan, text data, graphic data and external CG data can be freely allocated to the memory area (64 KB max).

With dual-scan, LCD-I is allocated to 0000h to 7FFFh (32 KB max), LCD-II is allocated to 8000h to FFFFh (32-KB Max). Text data, graphic data and external CG data can be freely allocated in LCD-I. In LCD-II, the same addresses must be allocated as in LCD-I, except A15. A15 determines selection of LCD-I or LCD-II.

It can be used the address-decoded signals $\overline{CE0}$ (0000h to 07FFh), $\overline{CE1}$ (0800h to 0FFFh) within 4 KB. $\overline{CE0}$ and $\overline{CE1}$ allow decoding of addresses in the ranges (0000h to 07FFh) and (0800h to 0FFFh) respectively within a 4-KB memory space.

(Example)

(1) Single-Scan

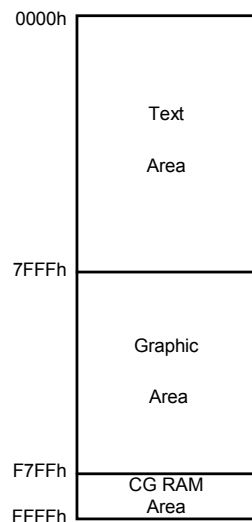

(2) Dual-Scan

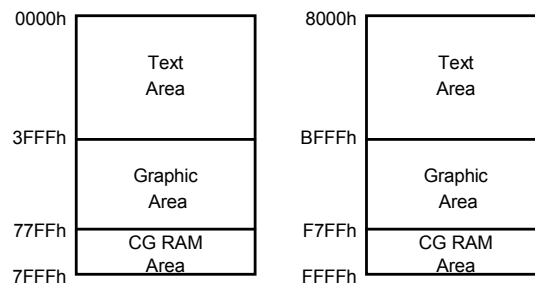

< Figure 6-1 >

6-5 Communications with MPU

6-5-1 Status Read

A status check must be performed before data is read or written.

Status Check

The Status of RA6963 can be read from the data lines.

< Table 6-3 >

\overline{RD}	\overline{WR}	\overline{CS}	C/\overline{D}	SD[7:0]
L	H	L	H	Status Word

The RA6963 status word format is as follows:

MSB				LSB			
SD7	SD6	SD5	SD4	SD3	SD2	SD1	SD0
STA7	STA6	STA5	STA4	STA3	STA2	STA1	STA0

< Table 6-4 >

STA0	Check command execution capability	0: Disable 1: Enable
STA1	Check data read/write capability	0: Disable 1: Enable
STA2	Check Auto mode data read capability	0: Disable 1: Enable
STA3	Check Auto mode data write capability	0: Disable 1: Enable
STA4	Not used	
STA5	Check controller operation capability	0: Disable 1: Enable
STA6	Error flag. Used for Screen copy commands.	0: No error 1: Error
STA7	Check the blink condition	0: Display off 1: Normal display

Note 1: It is necessary to check STA0 and STA1 at the same time.

There is a possibility of erroneous operation due to a hardware interrupt.

Note 2: For most modes STA0 /STA1 are used as a status check.

Note 3: STA2 and STA3 are valid in Auto mode; STA0 and STA1 are invalid.

Status Checking Flow

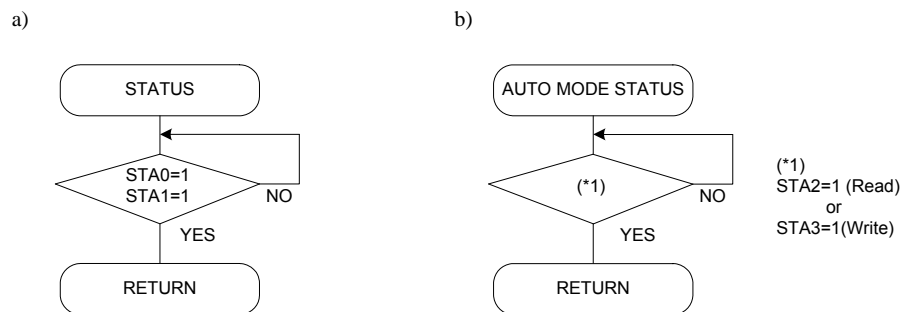

< Figure 6-2 >

Note 4: When using the MSB=0 command, a Status Read must be performed.
If a status check is not carried out, the RA6963 cannot operate normally, even after a delay time.

The hardware interrupt occurs during the address calculation period (at the end of each line).

If a MSB=0 command is sent to the RA6963 during this period, the RA6963 enters Wait status.

If a status check is not carried out in this state before the next command is sent, there is the possibility that the command or data will not be received.

6-5-2 Setting Data

When using the RA6963, first set the data, then set the command.

Procedure for Sending a Command

a) The case of 1 data

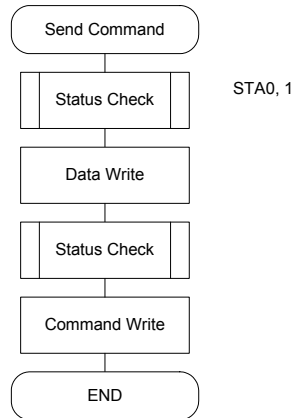

b) The case of 2 data

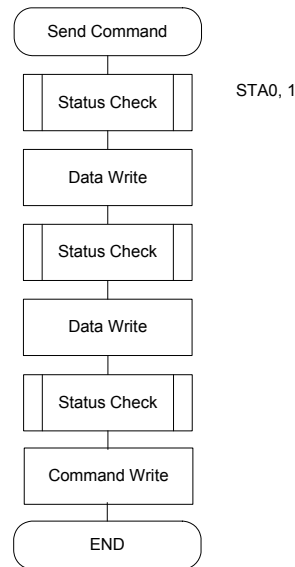

< Figure 6-3 >

Note : When sending more than two data, the last datum (or last two data) is valid.

6-5-3 Command Definitions

< Table 6-5 >

Command	Code	D1	D2	Function
Registers Setting	00100001	X address	Y address	Set cursor pointer
	00100010	Data	00h	Set Offset Register
	00100100	Low address	High address	Set Address pointer
Set Control Word	01000000	Low address	High address	Set Text Home Address
	01000001	Columns	00h	Set Text Area
	01000010	Low address	High address	Set Graphic Home Address
	01000011	Columns	00h	Set Graphic Area
Mode Set	1000X000	--	--	OR mode
	1000X001	--	--	EXOR mode
	1000X011	--	--	AND mode
	1000X100	--	--	Text Attribute mode
	10000XXX	--	--	Internal CG ROM mode
	10001XXX	--	--	External CG RAM mode
Display Mode	10010000	--	--	Display off
	1001XX10	--	--	Cursor on, blink off
	1001XX11	--	--	Cursor on, blink on
	100101XX	--	--	Text on, graphic off
	100110XX	--	--	Text off, graphic on
	100111XX	--	--	Text on, graphic on
Cursor Pattern Select	10100000	--	--	1-line cursor
	10100001	--	--	2-line cursor
	10100010	--	--	3-line cursor
	10100011	--	--	4-line cursor
	10100100	--	--	5-line cursor
	10100101	--	--	6-line cursor
	10100110	--	--	7-line cursor
	10100111	--	--	8-line cursor
Data auto Read/Write	10110000	--	--	Set Data Auto Write
	10110001	--	--	Set Data Auto Read
	10110010	--	--	Auto Reset
Data Read/Write	11000000	Data	--	Data Write and Increment ADP
	11000001	--	--	Data Read and Increment ADP
	11000010	Data	--	Data Write and Decrement ADP
	11000011	--	--	Data Read and Decrement ADP
	11000100	Data	--	Data Write and Non-variable ADP
	11000101	--	--	Data Read and Non-variable ADP
Screen Peek	11100000	--	--	Screen Peek
Screen Copy	11101000			Screen Copy
Bit Set/Reset	11110XXX	--	--	Bit Reset
	11111XXX	--	--	Bit Set
	1111X000	--	--	Bit 0 (LSB)
	1111X001	--	--	Bit 1
	1111X010	--	--	Bit 2
	1111X011	--	--	Bit 3
	1111X100	--	--	Bit 4
	1111X101	--	--	Bit 5
	1111X110	--	--	Bit 6
	1111X111	--	--	Bit 7 (MSB)

6-6 Setting Registers

< Table 6-6 >

Code	Hex.	Function	D1	D2
00100001	21h	Set Cursor Pointer	X-Adrs	Y-Adrs
00100010	22h	Set Offset Register	Data	00h
00100100	24h	Set Address Pointer	Low Adrs	High Adrs

6-6-1 Set Cursor Pointer

The X-Adrs and Y-Adrs specify the position of the cursor. The cursor position can only be moved by this command. Data read /write from the MPU never changes the cursor pointer. X-Adrs and Y-Adrs are specified as follows.

X-Adrs 00h to 4Fh (lower 7 bits are valid)
Y-Adrs 00h to 1Fh (lower 5 bits are valid)

a) Single-Scan
X-Adrs 00h to 4Fh

Y-Adrs 00h to 0Fh

b) Dual-Scan
X-Adrs 00h to 4Fh

Y-Adrs 00h to 0Fh Upper Screen
Y-Adrs 10h to 1Fh Lower Screen

6-6-2 Set Offset Register

The offset register is used to determine the external character generator RAM area. The RA6963 has a 16-bit address bus as follows:

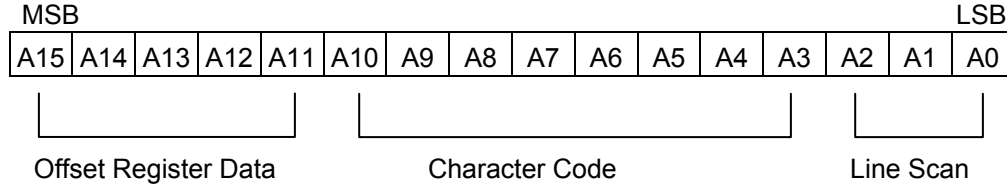

RA6963 assign External character generator, when character code set 80h to FFh in using Internal character generator. Character code 00h to 80h assign External character generator, when External generator mode.

The senior five bits define the start address in external memory of the CG RAM area. The next eight bits represent the character code of the character. In internal CG ROM mode, character Codes 00h to 7Fh represent the predefined “internal” CG ROM characters, and codes 80h to FFh Represent the user’s own “external” characters. In external CG RAM mode, all 256 codes from 00h to FFh can be used to represent the user’s own characters. The three least significant bits indicate one of the eight rows of eight dots that define the character’s shape.

The Relationship between Display RAM Address and Offset Register

Offset Register Data	CG RAM hex. Address (Start to End)
00000	0000 to 07FFh
00001	0800 to 0FFFh
00010	1000 to 17FFh
11100	E000 to E7FFh
11101	E800 to EFFFh
11110	F000 to F7FFh
11111	F800 to FFFFh

(Example 1)

Offset Register	02h				
Character Code	80h				
Character Generator RAM Start Address	0001	0100	0000	0000	
	1	4	0	0	h

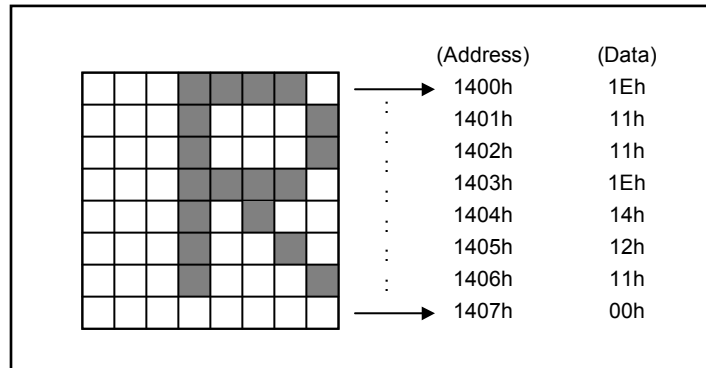

< Figure 6-4 >

(Example 2) The relationship between Display RAM data and display characters

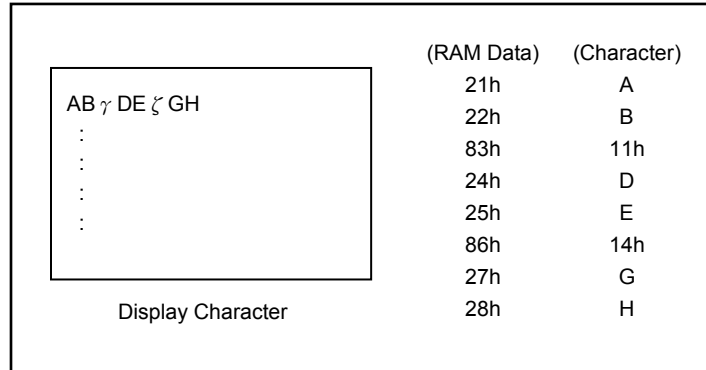

< Figure 6-5 >

The “γ” and “ζ” are displayed by character generator RAM.

6-6-3 Set Address Pointer

The Set Address Pointer command is used to indicate the start address for writing to (or reading from) External RAM.

The Flowchart for Set Address Pointer Command

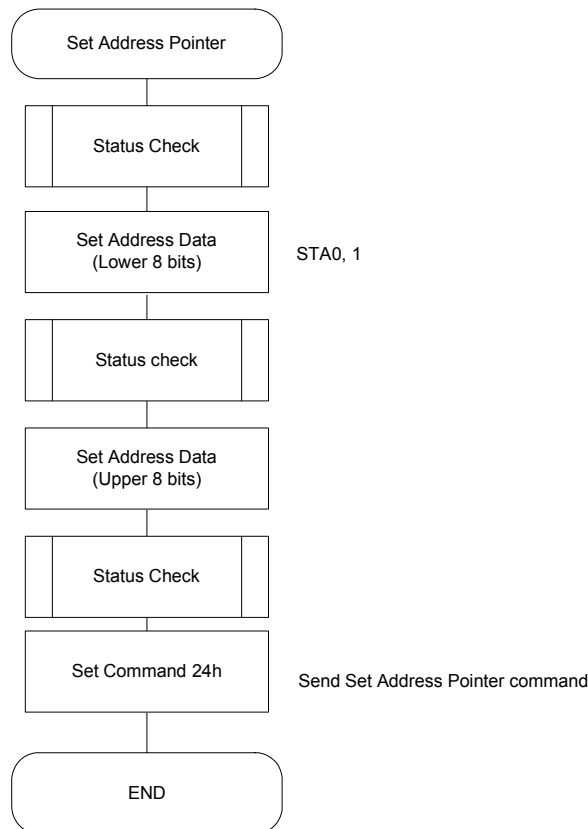

< Figure 6-6 >

6-7 Set Control Word

< Table 6-7 >

Code	Hex.	Function	D1	D2
01000000	40h	Set Text Home Address	Low Address	High Address
01000001	41h	Set Text Area	Columns	00h
01000010	42h	Set Graphic Home Address	Low Address	High Address
01000011	43h	Set Graphic Area	Columns	00h

The home address and column size are defined by this command.

6-7-1 Set Text Home Address

The starting address in the external display RAM for text display is defined by this command. The text home address indicates the leftmost and uppermost position.

The Relationship between Display RAM Address and Display Position

< Table 6-8 >

TH	TH + CL
TH + TA	TH + TA + CL
(TH + TA) + TA	TH + 2TA + CL
(TH + 2TA) + TA	TH + 3TA + CL
⋮	⋮	⋮
⋮	⋮	⋮
⋮	⋮	⋮
TH + (n-1) TA	TH + (n-1) TA + CL

TH: Text home address
TA: Text area number (columns)
CL: Columns are fixed by hardware (pin-programmable).

(Example)

Text Home Address : 0000h
Text Area : 0020h
MD2=H, MD3=H : 32 Columns
 $\overline{\text{DUAL}}$ =H, MDS=L, MD0=L, MD1=H : 4 Lines

< Table 6-9 >

0000h	0001h	001Eh	001Fh
0020h	0021h	003Eh	002Fh
0040h	0041h	005Eh	005Fh
0060h	0061h	007Eh	007Fh

6-7-2 Set Graphic Home Address

The starting address of the external display RAM used for graphic display is defined by this command. The graphic home address indicates the leftmost and uppermost position.

The Relationship between External Display RAM Address and Display Position

< Table 6-10 >

GH	GH + CL
GH + GA	GH + GA + CL
(GH + GA) + GA	GH + 2GA + CL
(GH + 2GA) + GA	GH + 3GA + CL
⋮	⋮	⋮
⋮	⋮	⋮
⋮	⋮	⋮
⋮	⋮	⋮
GH + (n-1) GA	GH + (n-1) GA + CL

GH: Graphic Home Address

GA: Graphic Area Number (columns)

CL: Columns are fixed by hardware (pin-programmable).

(Example)

Graphic Home Address : 0000h
 Graphic Area : 0020h
 MD2=H, MD3=H : 32 columns
 DUAL =H, MDS=L, MD0=H, MD1=H : 2 lines

< Table 6-11 >

0000h	0001h	001Eh	001Fh
0020h	0021h	003Eh	003Fh
0040h	0041h	005Eh	005Fh
0060h	0061h	007Eh	007Fh
0080h	0081h	009Eh	009Fh
00A0h	00A1h	00BEh	00BFh
00C0h	00C1h	00DEh	00DFh
00E0h	00E1h	00FEh	00FFh
0100h	0101h	011Eh	011Fh
0120h	0121h	013Eh	013Fh
0140h	0141h	015Eh	015Fh
0160h	0161h	017Eh	017Fh
0180h	0181h	019Eh	019Fh
01A0h	01A1h	01BEh	01BFh
01C0h	01C1h	01DEh	01DFh
01E0h	01E1h	01FEh	01FFh

6-7-3 Set Text Area

The display columns are defined by the hardware setting. This command can be used adjust the columns of the display.

(Example)

LCD Size : 20 columns, 4 lines
 Text Home Address : 0000h
 Text Area : 0014h
 MD2=H, MD3=H : 32 columns
 DUAL =H , MDS =L, MD0= L, MD1=H : 4 lines

< Table 6-12 >

0000	0001	0013	0014	001F
0014	0015	0027	0028	0033
0028	0029	003B	003C	0047
003C	003D	004F	0050	005B



6-7-4 Set Graphic Area

The display columns are defined by the hardware setting. This command can be used to adjust the columns of the graphic display.

(Example)

LCD Size : 20 columns, 2 lines
 Graphic Home Address : 0000h
 Graphic Area : 0014h
 MD2=H, MD3=H : 32 columns
 $\overline{\text{DUAL}} = \text{H}$, MDS=L MD0=H, MD1=H : 2 lines

< Table 6-13 >

0000	0001	0013	0014	001F
0014	0015	0027	0028	0033
0028	0029	003B	003C	0047
003C	003D	004F	0050	005B
0050	0051	0063	0064	006F
0064	0065	0077	0078	0083
0078	0079	008B	008C	0097
008C	008D	009F	00A0	00AB
00A0	00A1	00B3	00B4	00BF
00B4	00B5	00C7	00C8	00D3
00C8	00C9	00DB	00DC	00E7
00DC	00DD	00EF	00F0	00FD
00F0	00F1	0103	0104	011F
0104	0105	0127	0128	0123
0128	0129	013B	013C	0147
013C	013D	014F	0150	015B

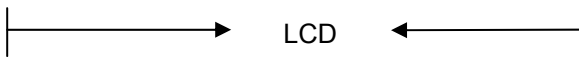

If the graphic area setting is set to match the desired number of columns on the LCD, the addressing scheme will be automatically modified so that the start address of each line equals the end address of the previous line +1.

6-8 Mode Set

< Table 6-14 >

Code	Function	Operand
1000X000	OR Mode	—
1000X001	EXOR Mode	—
1000X011	AND Mode	—
1000X100	Text Attribute Mode	—
10000XXX	Internal Character Generator Mode	—
10001XXX	External Character Generator Mode	—

X: Invalid

The display mode is defined by this command. The display mode does not change until the next command is sent. The logical OR, EXOR, AND of text or graphic display can be displayed.

In internal Character Generator mode, character codes 00h to 7Fh are assigned to the built-in Character generator ROM. The character codes 80h to FFh are automatically assigned to the external character generator RAM.

(Example)

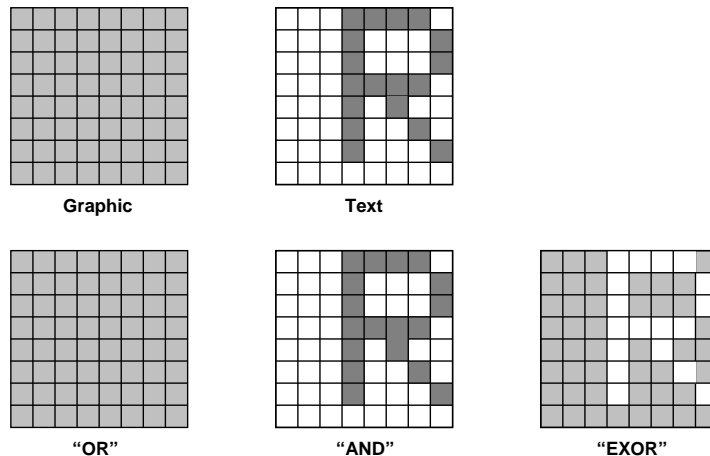

< Figure 6-7 >

Note: Attribute functions can only be applied to text display, since the attribute data is placed in the graphic RAM area.

Attribute Function

The attribute operations are Reverse display, Character blink, bold and Inhibit. The attribute data is written into the graphic area, which was defined by the Set Control word command. Only text display is possible in Attribute Function mode; graphic display is automatically disabled. However, the Display Mode command must be used to turn both Text and Graphic on that in order to for the Attribute function available.

The attribute data for each character in the text area is written to the same address in the graphic area.

The Attribute function is defined as follows.

Attribute RAM 1byte

X	X	X	X	d3	d2	d1	d0
---	---	---	---	----	----	----	----

X: Invalid

< Table 6-15 >

d3	d2	d1	d0	Function
0	0	0	0	Normal Display
0	1	0	1	Reverse Display
0	0	1	1	Inhibit Display
1	0	0	0	Blink of Normal Display
1	1	0	1	Blink of Reverse Display
1	0	1	1	Blink of Inhibit Display

6-9 Display Mode

< Table 6-16 >

Code	Function	Operand
10010000	Display off	—
1001XX10	Cursor on, Blink off	—
1001XX11	Cursor on, Blink on	—
100101XX	Text on, Graphic off	—
100110XX	Text off, Graphic on	—
100111XX	Text on, Graphic on	—

X: Invalid

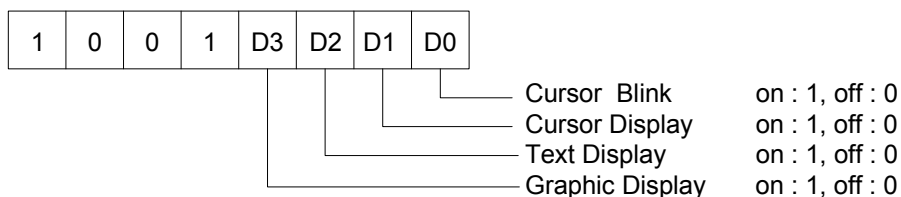

Note: It is necessary to turn on “Text Display” and “Graphic Display” in the following cases.
 a) Combination of text /graphic display
 b) Attribute function

6-10 Cursor Pattern Select

< Table 6-17 >

Code	Function	Operand
10100000	1-line cursor	—
10100001	2-line cursor	—
10100010	3-line cursor	—
10100011	4-line cursor	—
10100100	5-line cursor	—
10100101	6-line cursor	—
10100110	7-line cursor	—
10100111	8-line cursor	—

When cursor display is ON, this command selects the cursor pattern in the range 1 line to 8 lines. The cursor address is defined by the Cursor Pointer Set command.

6-11 Data Auto Read/Write

< Table 6-18 >

Code	Hex.	Function	Operand
10110000	B0h	Set Data Auto Write	—
10110001	B1h	Set Data Auto Read	—
10110010	B2h	Auto Reset	—

This command is convenient for sending a full screen of data from the external display RAM. After Setting Auto mode, a Data Write (or Read) command does not need sent between each datum. A Data Auto Write (or Read) command must be sent after a Set Address Pointer command. After this Command, the address pointer is automatically incremented by 1 after each datum. In Auto mode, the RA6963 cannot accept any other commands.

The Auto Reset command must be sent to the RA6963 after all data has been sent, to clear Auto Mode.

Note : A Status Check for Auto Mode

STA2, STA3 should be checked between sending of each datum. Auto Reset should be performed after checking STA3=1 (STA2=1). Refer to the following flowchart.

a) Auto Read mode

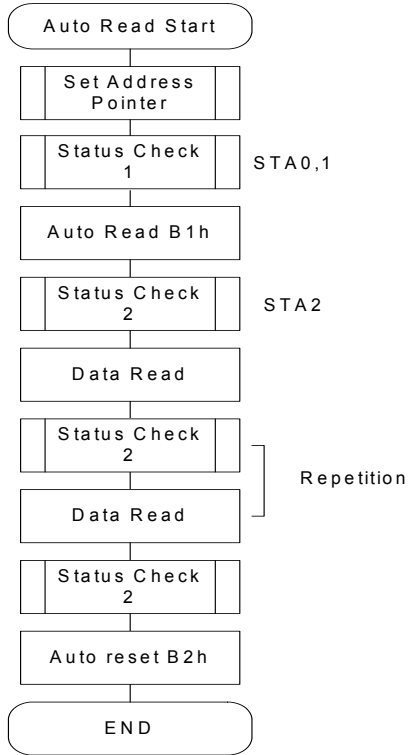

b) Auto Write mode

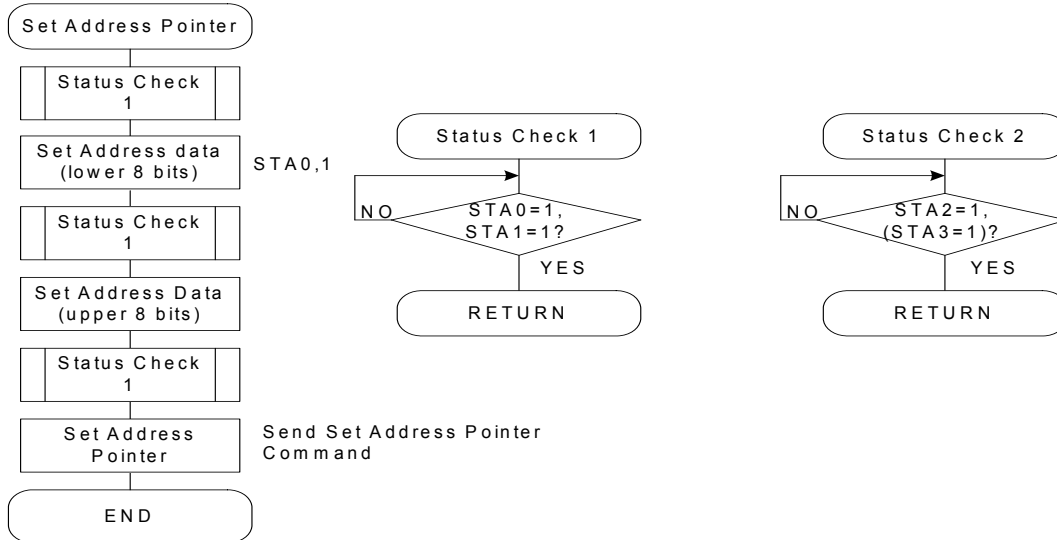
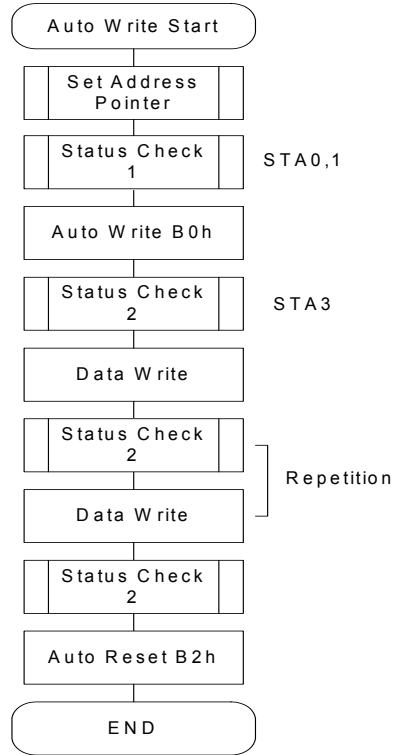

< Figure 6-8 >

6-12 Data Read/Write

< Table 6-19 >

Code	Hex.	Function	Operand
11000000	C0h	Data Write and Increment ADP	Data
11000001	C1h	Data Read and Increment ADP	—
11000010	C2h	Data Write and Decrement ADP	Data
11000011	C3h	Data Write and Decrement ADP	—
11000100	C4h	Data Write and Non-variable ADP	Data
11000101	C5h	Data Read and Non-variable ADP	—

This command is used for writing data from the MPU to external display RAM, and reading data from external display RAM to the MPU. Data Write / Data Read should be executed after setting address using Set Address Pointer command, The address pointer can be automatically incremented or decremented using this command.

Note: This command is necessary for each 1-byte datum.

Refer to the following flowchart.

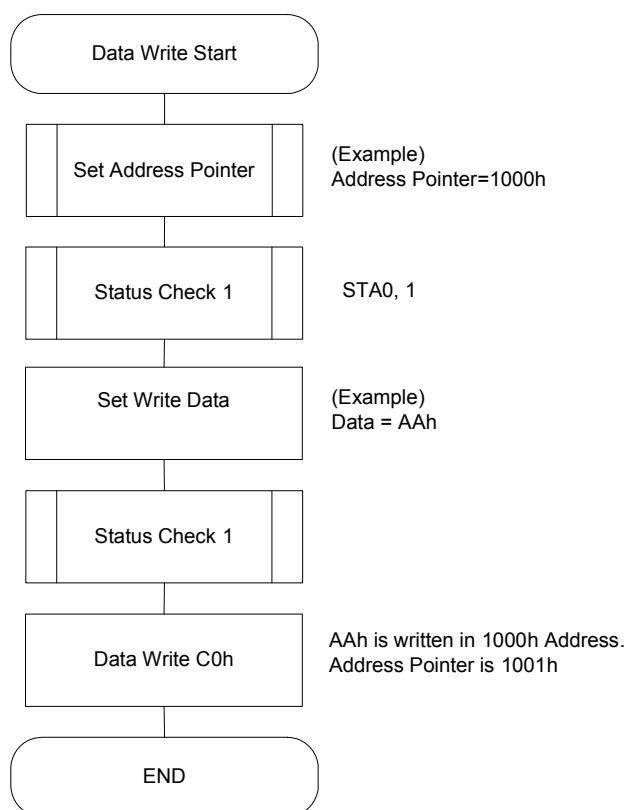

< Figure 6-9 >

6-13 Screen Peek

< Table 6-20 >

Code	Hex.	Function	Operand
11100000	E0h	Screen Peek	—

This command is used to transfer 1 byte of displayed data to the data stack; this byte can be read from the MPU by data access. The logical combination of text and graphic display data on the LCD screen can be read by this command.

The status (STA6) should be checked just after the Screen Peek command. If the address determined by the Set Address Pointer command is not in the graphic area, this command is ignored and a status flag (STA6) is set.

Refer to the following flowchart.

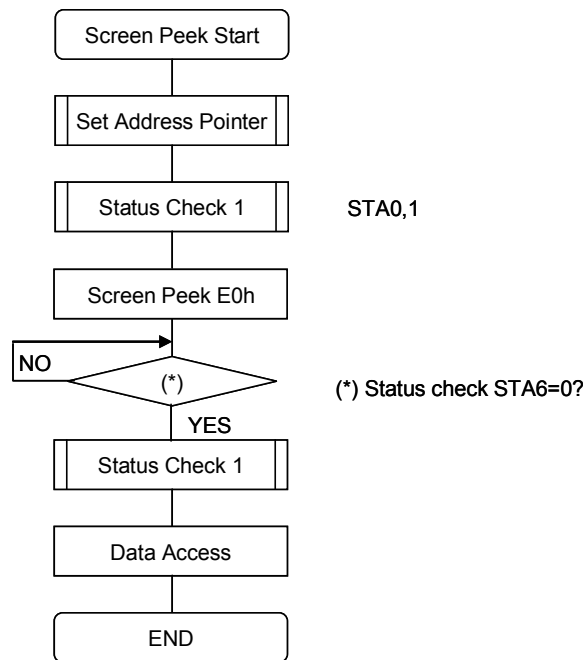

< Figure 6-10 >

Note: This command is available when hardware column number and software column number are the same. Hardware column number is related to MD2 and MD3 setting. Software column number is related to Set Text Area and Set Graphic Area command.

6-14 Screen Copy

< Table 6-21 >

Code	Hex.	Function	Operand
11101000	E8h	Screen Copy	—

This command copies a single raster line of data to the graphic area. The start point must be set using the Set Address Pointer command.

Note 1: If the attribute function is being used, this command is not available. (With Attribute data is graphic area data.)

Note 2: With Dual-Scan, this command cannot be used (because the RA6963 cannot separate the upper screen data and lower screen data).

Refer to the following flowchart.

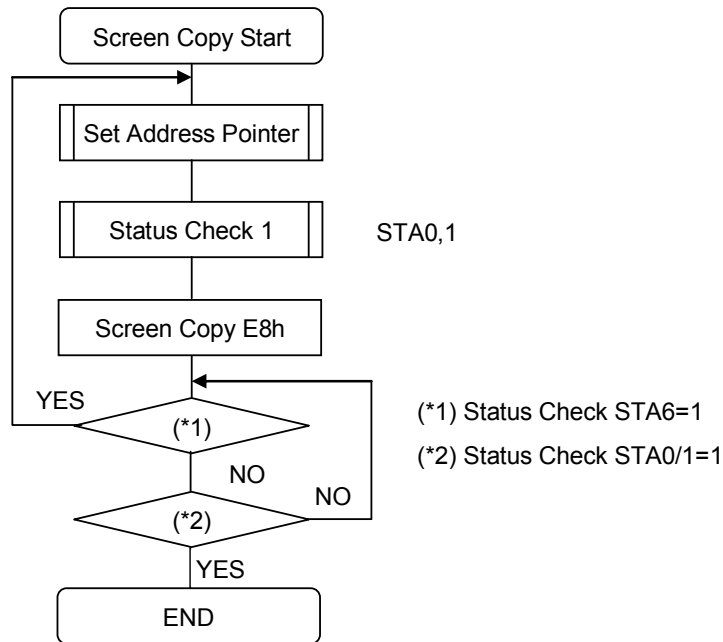

< Figure 6-11 >

Note : This command is available when hardware column number and software column number are the same. Hardware column number is related to MD2 and MD3 setting. Software column number is related to Set Text Area and Set Graphic Area command.

6-15 Bit Set/Reset

< Table 6-22 >

Code	Function	Operand
11110XXX	Bit Reset	—
11111XXX	Bit Set	—
1111X000	Bit 0 (LSB)	—
1111X001	Bit 1	—
1111X010	Bit 2	—
1111X011	Bit 3	—
1111X100	Bit 4	—
1111X101	Bit 5	—
1111X110	Bit 6	—
1111X111	Bit 7 (MSB)	—

X: Invalid

This command used to set or reset a bit of the byte specified by the address pointer. Only one bit can be set / reset at time.

Refer to following flowchart.

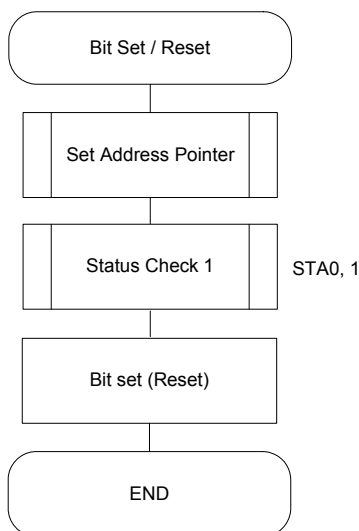

< Figure 6-12 >

6-16 Character Font Map

CGROM Font - 01

LSB \ MSB	0	1	2	3	4	5	6	7	8	9	A	B	C	D	E	F
0		!	"	#	\$	%	&	'	()	*	+	,	-	.	/
1	0	1	2	3	4	5	6	7	8	9	:	;	<	=	>	?
2	a	A	B	C	D	E	F	G	H	I	J	K	L	M	N	O
3	P	Q	R	S	T	U	V	W	X	Y	Z	[\]	^	_
4	`	a	b	c	d	e	f	g	h	i	j	k	l	m	n	o
5	p	q	r	s	t	u	v	w	x	y	z	{		}	~	
6	ü	û	ë	ä	å	ä	å	ö	è	é	ê	ë	ì	í	î	ï
7	é	æ	è	ø	ø	ø	ó	ô	õ	ö	ó	ø	£	¥	℞	ƒ

< Figure 6-13 >

CGROM Font - 02

LSB \ MSB	0	1	2	3	4	5	6	7	8	9	A	B	C	D	E	F
0		!	"	#	\$	%	&	'	()	*	+	,	-	.	/
1	0	1	2	3	4	5	6	7	8	9	:	;	<	=	>	?
2	a	A	B	C	D	E	F	G	H	I	J	K	L	M	N	O
3	P	Q	R	S	T	U	V	W	X	Y	Z	[\]	^	_
4	千	万	月	夕	夕	■	ヲ	ア	イ	ウ	エ	オ	カ	ク	ケ	コ
5	一	ア	イ	ウ	エ	オ	カ	キ	ク	ケ	コ	サ	シ	ス	セ	ソ
6	タ	チ	ツ	テ	ト	ナ	ニ	ヌ	ネ	ノ	ヒ	フ	ヘ	ホ	マ	メ
7	ミ	ム	メ	モ	ヤ	ユ	ヨ	ラ	リ	ル	レ	ロ	ワ	ウ	エ	オ

< Figure 6-14 >

The RA6963 has two part number - RA6963L2NA and RA6963L2NB. The RA6963L2NA is compatible to T6963C(code 0101) and the default font is Figure 6-13 as above. The RA6963L2NB is compatible to T6963C(code 0201) and the default font is Figure 6-14 as above.

7. Package Dimensions

7-1 Outline Drawing

LQFP-67Pin

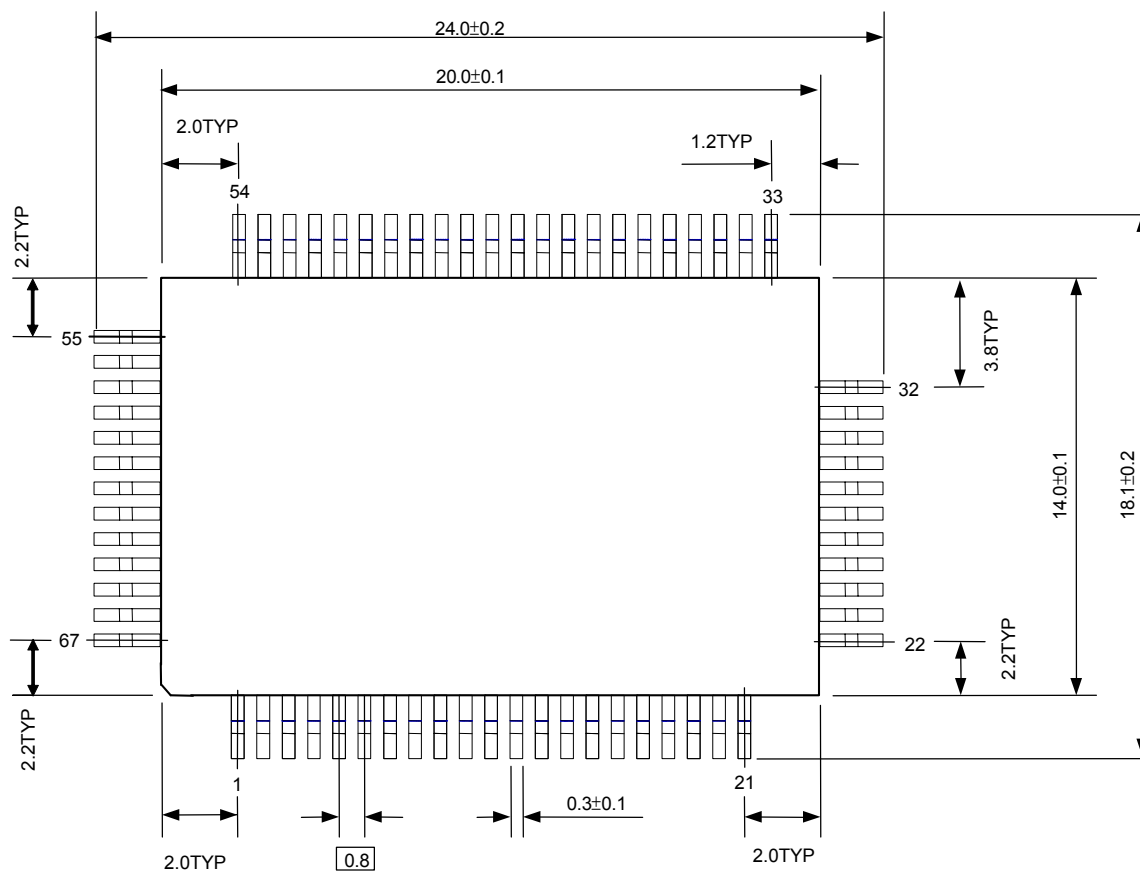

< Figure 7-1 >

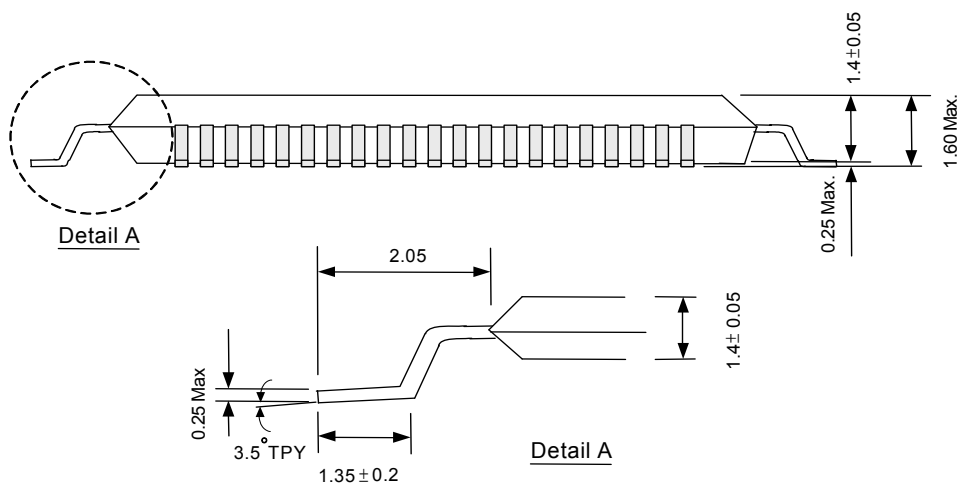

< Figure 7-2 >

8. Specifications

8-1 Absolute Maximum Ratings

< Table 8-1 >

Ta=25°C

Parameter	Symbol	Rating	Unit
Supply Voltage Range	V _{DD} (Note 1)	-0.3 to +7.0	V
Input Voltage Range	V _{in} (Note 1)	-0.3 to V _{DD} +0.3	V
Operating Temperature Range	T _{op}	-30 to +85	°C
Storage Temperature Range	T _{stg}	-55 to +125	°C
Solder Temperature Range	T _{sdt} (Note 2)	400	°C

Note 1 : Gnd = 0V.

Note 2 : Solder Time = 8 Minutes.

< Table 8-2 >

(V_{DD}=3.0 to 5.5V, GND=0V, Ta= -20 to +70°C)

Item	Symbol	Test Conditions	Min.	Typ.	Max.	Unit	Pin Name
Operating Voltage	V _{DD}	V _{DD}	--	3.0	5.5	V	VDD
Input	"H"	V _{IH}	--	0.8V _{DD}	V _{DD}	V	I/P
	"L"	V _{IL}	--	0	0.15V _{DD}	V	I/P
Output	"H"	V _{OH}	--	V _{DD} -0.3	V _{DD}	V	O/P
	"L"	V _{OL}	--	0	0.3	V	O/P
Output Resistance	"H"	R _{OH} V _{OUT} =V _{DD} -0.5	--	--	400	Ω	O/P
	"L"	R _{OL} V _{OUT} =0.5	--	--	400	Ω	O/P
Current Consumption	Operating	I _{DD} V _{DD} =5.0V (Note 2) f _{OSC} =4.0MHz	--	3.0	5	mA	VDD
	Halt	I _{DD} V _{DD} =5.0V	--	1	2	μA	VDD
Input Pull Up Resistance	RPU	--	50	100	300	KΩ	(Note 1)
Operating Frequency	f _{OSC}	--	0.4	8	--	MHz	
Solder Temperature	T _{SdT}	(Note 3)	--	260	--	°C	

Note 1: Applied $\overline{\text{TEST}}[2:1]$, $\overline{\text{RST}}$.

Note 2: MDS=L, MD[1:0]=LL, MD[3:2]=HH, FS[1:0]=LL, $\overline{\text{SDSEL}}=L$, $\overline{\text{DUAL}}=H$, D[7:0]=LHLHLHLH.

Note 3: Solder Time = 20~40 Seconds.

8-2 MPU Interface Timing

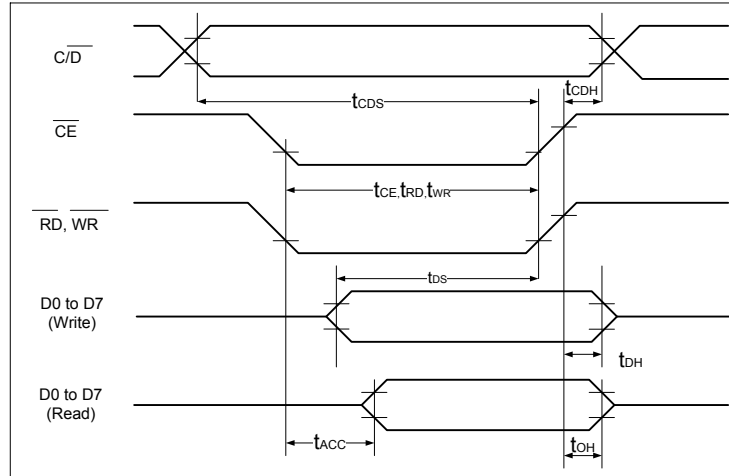

< Figure 8-1 >

< Table 8-3 >

($V_{DD}=+5V\pm 5\%$, $GND=0V$, $T_a = -20$ to $+70^\circ C$)

Item	Symbol	Test Conditions	Min.	Max.	Unit
C/D Set Up Time	t_{CDS}	--	100	--	ns
C/D Hold Time	t_{CDH}	--	10	--	ns
CE, RD, WR Pulse Width	t_{CE}, t_{RD}, t_{WR}	--	80	--	ns
Data Set Up Time	t_{DS}	--	80	--	ns
Data Hold Time	t_{DH}	--	40	--	ns
Access Time	t_{ACC}	--	--	150	ns
Output Hold Time	t_{OH}	--	10	50	ns

8-3 Driver Interface Timing

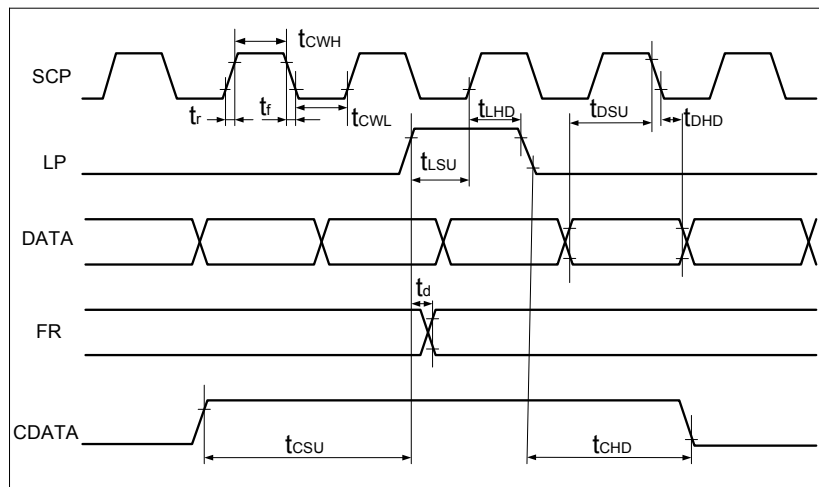

< Figure 8-2 >

< Table 8-4 >

($V_{DD}=+5V\pm 5\%$, $GND=0V$, $T_a = -20$ to $+70^\circ C$)

Item	Symbol	Test Conditions	Min.	Max.	Unit
Operating Frequency	f_{SCP}	$T_a = -20\sim 70^\circ C$	--	9	MHz
SCP Pulse Width	t_{CWH}, t_{CWL}	--	150	--	ns
SCP Rise/Fall Time	t_r, t_f	--	--	30	ns
LP Setup Time	t_{LSU}	--	150	290	ns
LP Hold Time	t_{LHD}	--	5	40	ns
Data Setup Time	t_{DSU}	--	170	--	ns
Data Hold Time	t_{DHD}	--	80	--	ns
FR Delay Time	t_d	--	0	90	ns
CDATA Setup Time	t_{CSU}	--	450	850	ns
CDATA Hold Time	t_{CHD}	--	450	950	ns

8-4 External Memory Interface

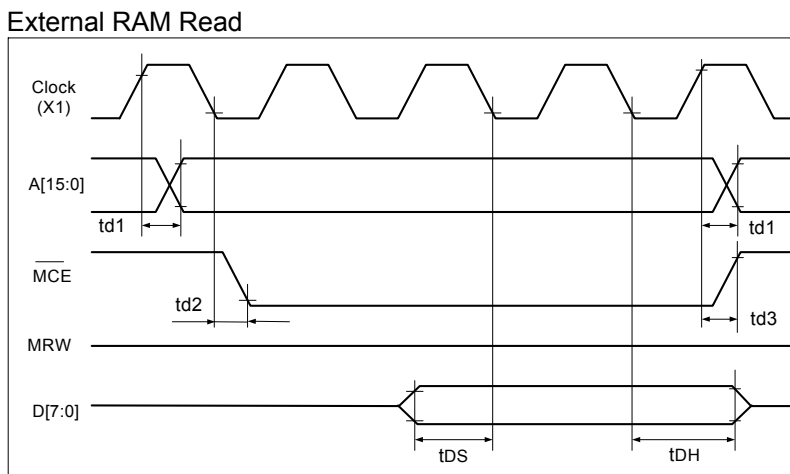

< Figure 8-3 >

External RAM Write

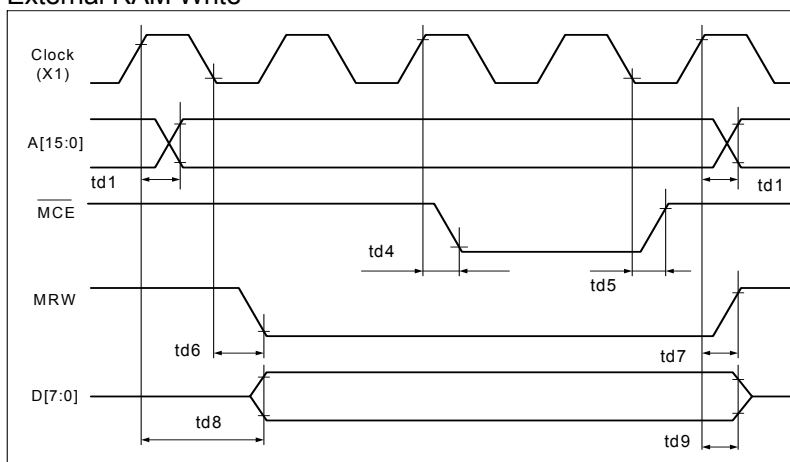

< Figure 8-4 >

< Table 8-5 >

($V_{DD}=+5V\pm 5\%$, $GND=0V$, $T_a = -20$ to $+70^\circ C$)

Item	Symbol	Test Conditions	Min.	Max.	Unit
Address Delay Time	t_{d1}	--	--	250	ns
MCE Fall Delay Time(Read)	t_{d2}	--	--	180	ns
MCE Rise Delay Time(Read)	t_{d3}	--	--	180	ns
Data Setup Time	t_{DS}	--	0	--	ns
Data Hold Time	t_{DH}	--	30	--	ns
MCE Fall Delay Time(Write)	t_{d4}	--	--	200	ns
MCE Rise Delay Time(Write)	t_{d5}	--	--	200	ns
MRW Fall Delay Time	t_{d6}	--	--	180	ns
MRW Rise Delay Time	t_{d7}	--	--	180	ns
Data Stable Time	t_{d8}	--	--	450	ns
Data Hold Time	t_{d9}	--	--	200	ns

9. Application

The RA6963 can be directly connected to Z80(Note 1) series MPU. The following applications are use a TMPZ84C00A to connect RA6963.

9-1 MPU Memory Address Mapping

Data is transferred to the RA6963 using a memory request signal.

< Table 9-1 >

	Address
DATA (I/O)	XXXXh
Command/Status	XXXX + 1h

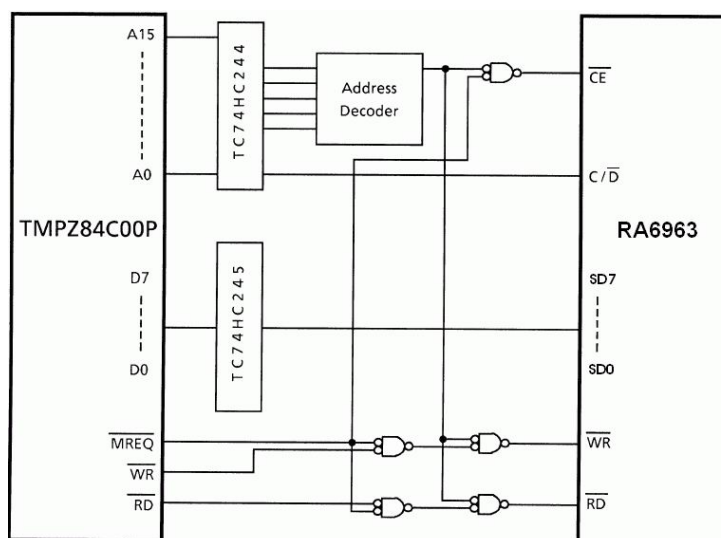

< Figure 9-1 >

Note 1: Z80 is a trademark of Zilog Inc.

9-2 MPU I/O Addressing

Data is transferred to the RA6963 using an I/O request signal.

< Table 9-2 >

	I/O Address
DATA	XXh
Command / Status	XX + 1h

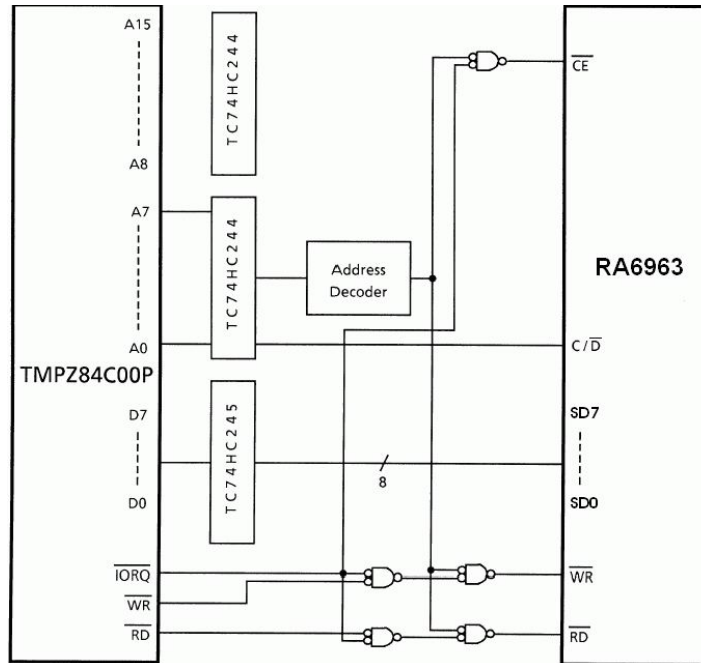

< Figure 9-2 >

9-3 Use PPI LSI

The RA6963 can be connected to a PPI LSI.

The port A connects to the data bus.

The port C connects to the control bus. ($\overline{C/D}$, \overline{CE} , \overline{WR} , \overline{RD})

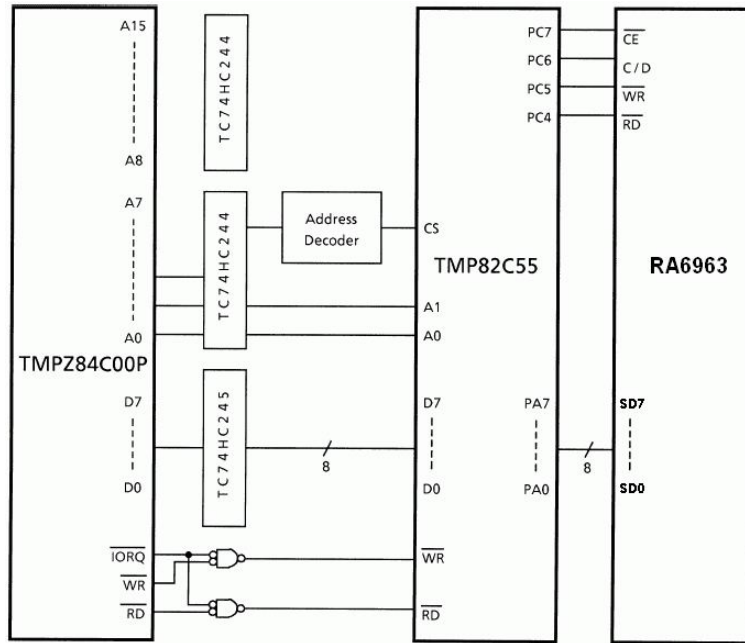

< Figure 9-3 >

9-4 Application Block Diagram

All LCD require two power sources, VDD for logic circuits and VEE for Liquid Crystal (LC) drive. Some graphics LCD modules will run directly of a single VDD supply by generating the VEE voltage on-board; others will require an external DC-DC converter to generate the negative VEE voltage. Refer to individual specifications for details.

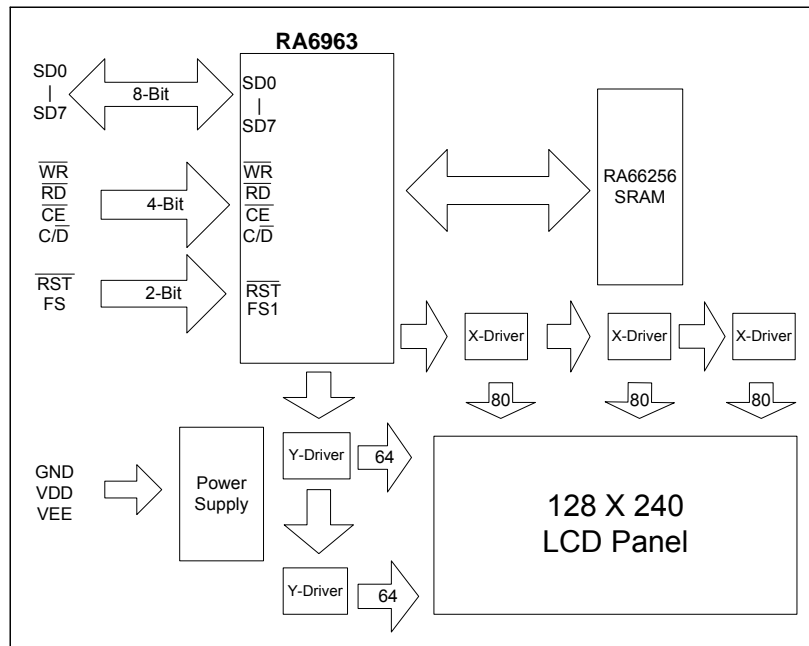

< Figure 9-4 >

9-5 Application Circuit(1)

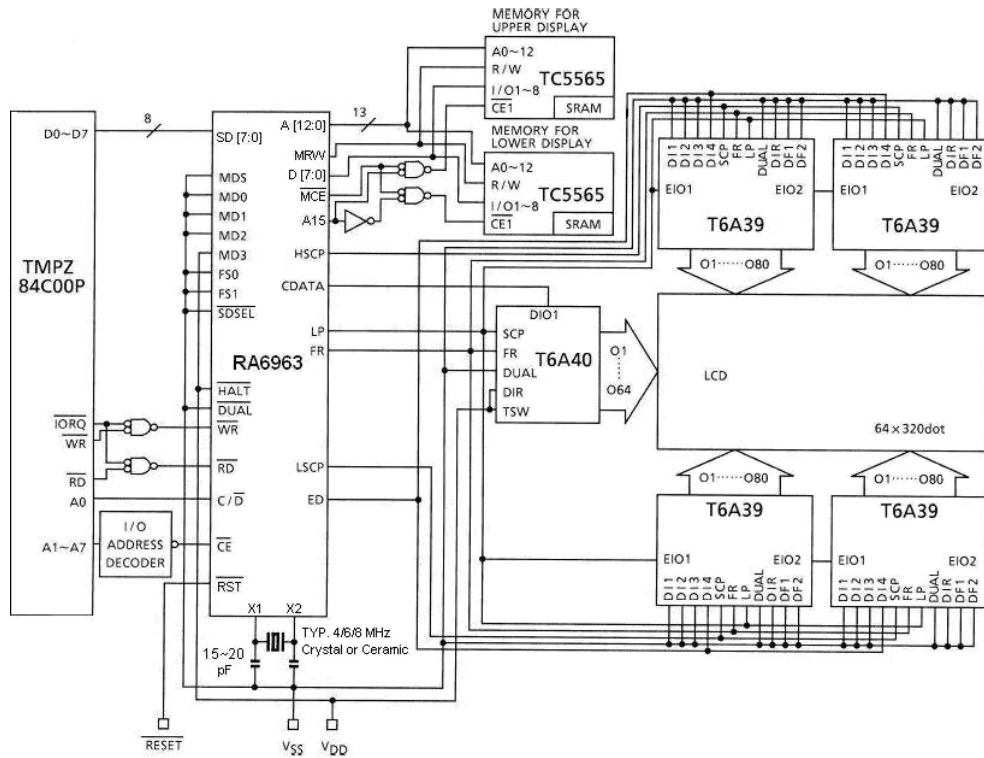

< Figure 9-5 >

9-6 Application Circuit(2)

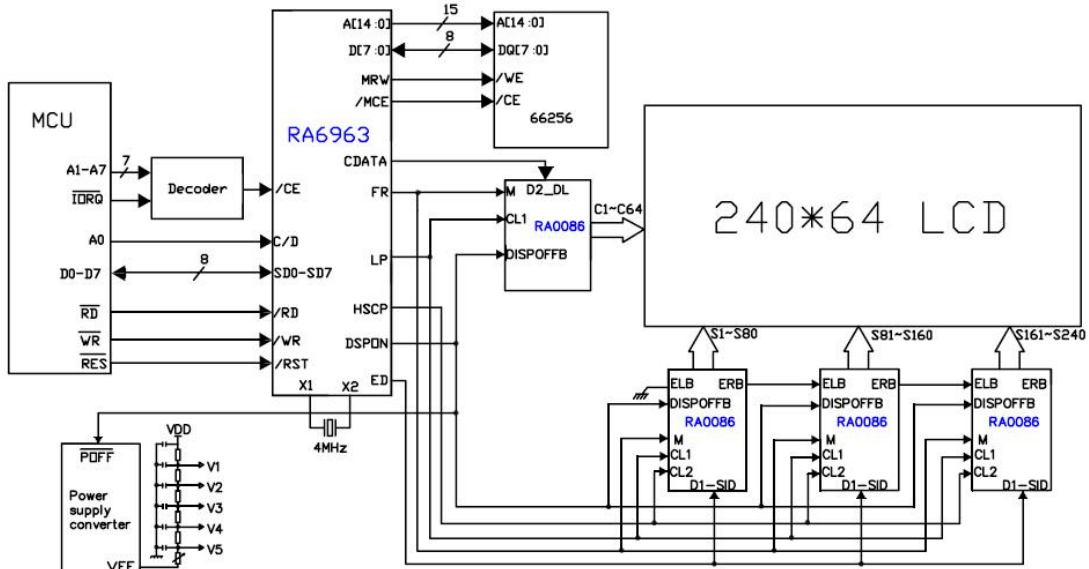

< Figure 9-6 >

