

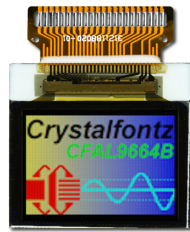

DISPLAY MODULE DATASHEET



Datasheet Release 2016-04-01
for
[CFAL9664B-F-B2](#)

Crystalfontz America, Incorporated

12412 East Saltese Avenue
Spokane Valley, WA 99216-0357

Phone: 888-206-9720

Fax: 509-892-1203

Email: support@crystalfontz.com

URL: www.crystalfontz.com



CONTENTS

GENERAL INFORMATION	3
Module Classification Information	4
Features	4
Comparison to LCD (Liquid Crystal Display) Module	5
Mechanical Data	6
Module Outline Drawing	7
Details of Interface Pin Functions	8
Block Diagram	9
ELECTRICAL SPECIFICATIONS	9
Absolute Maximum Ratings	9
DC Characteristics (3.3v Operation)	10
Optical Characteristics	11
ESD (Electro-Static Discharge) Specifications	11
AC Characteristics	12
FUNCTIONAL SPECIFICATIONS AND APPLICATION CIRCUIT	15
Power On And Power Off Sequence	15
Application Circuit	16
Example Of External DC-DC Application Circuit	17
MODULE RELIABILITY AND LONGEVITY	18
Display Module Reliability Test Results	18
Module Reliability	19
Module Longevity (EOL / Replacement Policy)	19
Sources For Driver Libraries	19



GENERAL INFORMATION

Datasheet Revision History

Datasheet Release: 2016-04-01
Datasheet for new OLED, the CFAL9664B-F-B2 display module.

Product Change Notifications

To check for Product Change Notifications for this display module, see the Product Notices tab on the product's web page:
https://www.crystalfontz.com/products/product.php?product_id=4205#pcn

Product pages without a Product Notices tab do not have Product Change Notifications.

About Variations

Slight variations (for example, contrast, color, or intensity) between lots are normal.

About Volatility

This display module has volatile memory.



The Fine Print

Certain applications using CrystalFontz America, Inc. products may involve potential risks of death, personal injury, or severe property or environmental damage (“Critical Applications”). CRYSTALFONTZ AMERICA, INC. PRODUCTS ARE NOT DESIGNED, INTENDED, AUTHORIZED, OR WARRANTED TO BE SUITABLE FOR USE IN LIFE-SUPPORT APPLICATIONS, DEVICES OR SYSTEMS OR OTHER CRITICAL APPLICATIONS. Inclusion of CrystalFontz America, Inc. products in such applications is understood to be fully at the risk of the customer. In order to minimize risks associated with customer applications, adequate design and operating safeguards should be provided by the customer to minimize inherent or procedural hazard. Please contact us if you have any questions concerning potential risk applications.

CrystalFontz America, Inc. assumes no liability for applications assistance, customer product design, software performance, or infringements of patents or services described herein. Nor does CrystalFontz America, Inc. warrant or represent that any license, either express or implied, is granted under any patent right, copyright, or other intellectual property right of CrystalFontz America, Inc. covering or relating to any combination, machine, or process in which our products or services might be or are used.

All specifications in Datasheets and on our website are, to the best of our knowledge, accurate but not guaranteed. Corrections to specifications are made as any inaccuracies are discovered.

Company and product names mentioned in this publication are trademarks or registered trademarks of their respective owners.

Copyright © 2016 by CrystalFontz America, Inc., 12412 East Saltese Avenue, Spokane Valley, WA 99216-0357 U.S.A

MODULE CLASSIFICATION INFORMATION

<u>CFA</u>	<u>L</u>	<u>96</u>	<u>64</u>	<u>B</u>	-	<u>F</u>	-	<u>B2</u>
①	②	③	④	⑤		⑥		⑦

①	Brand	CrystalFontz America, Inc.
②	Display Type	L – OLED
③	Number of Pixels (Width)	96 pixels
④	Number of Pixels (Height)	64 pixels
⑤	Model Identifier	B
⑥	Display Color	F – Full color
⑦	Special Code	B2 – Manufacturer’s codes

FEATURES

- This 65k full color emissive display module is 96 millimeters wide x 3 (RGB) x 64 OLED with an FPC cable (tail).
- Panel is 24.80 (W) x 22.42 (H) x 1.33 (D) millimeters.
- Overall height panel with cable unfolded is 29.62 millimeters.
- 8-bit parallel (8080 or 6800) or SPI Interface.



- Built-in [Solomon Systech SSD1331](#) 96 x RGB x 64 Dot Matrix OLED/PLED Segment/Common Driver with Controller.
- If you manufacture a high volume of your product, connecting is fast and easy with a hot-bar solder machine.
- Extremely wide viewing angle is $>160^\circ$.
- Temperature range for operation is -30°C to $+70^\circ\text{C}$.
- Storage temperature range is -30°C to $+80^\circ\text{C}$.
- Free sample code is available for download under the Datasheets & Files tab on the product's web page.
- This display is RoHS compliant.
- CrystalFontz America Incorporated is ISO 9001:2008 certified.

COMPARISON TO LCD (LIQUID CRYSTAL DISPLAY) MODULE

The CFAL9664B-F-B2 is a full color 96 x 64 dot matrix Organic Light-Emitting Diode (OLED) display module. The small size, ultra-thin form factor, and full color capability of the CFAL9664B-F-B2 makes it possible to use this OLED module in applications where it would be difficult or impossible to fit a traditional LCD module. The module's small size makes it possible to use the CFAL9664B-F-B2 in space constrained applications such as a status display on a disk drive or server blade. Because of the low power requirements, the CFAL9664B-F-B2 is suitable in battery powered portable devices such as remote controls and scientific meters (for example, temperature, sound, and gas detection). Full color allows information to be quickly perceived. For example, use red to indicate a fault and green to indicate normal operation.

Compared to most LCD modules, this OLED module has a quicker response time and an extremely wide viewing angle. At the low end of an STN LCD's temperature range, a module's contrast will typically be poor and the response time will be very slow. Unlike an STN LCD module, contrast does not diminish and response time is good at the lower end of an OLED module's operating temperature range, allowing it to operate in cold environments without a heater.



MECHANICAL DATA

NO.	ITEM	SPECIFICATION	UNIT
1	Dot Matrix	96(W)(RGB)×64(H)	-
2	Dot Size	0.045(W)×0.19 (H)	mm ²
3	Dot Pitch	0.07(W)×0.21 (H)	mm ²
4	Aperture Rate	58	%
5	Active Area	20.135(W)×13.42 (H)	mm ²
6	Panel Size	24.8(W)×22.42(H) ×1.1(T)	mm ³
7	Module Size	24.8(W)×29.62(H) ×1.33(T)	mm ³
8	Diagonal A/A Size	0.95	inch
9	Module Weight	1.4	gram



MODULE OUTLINE DRAWING

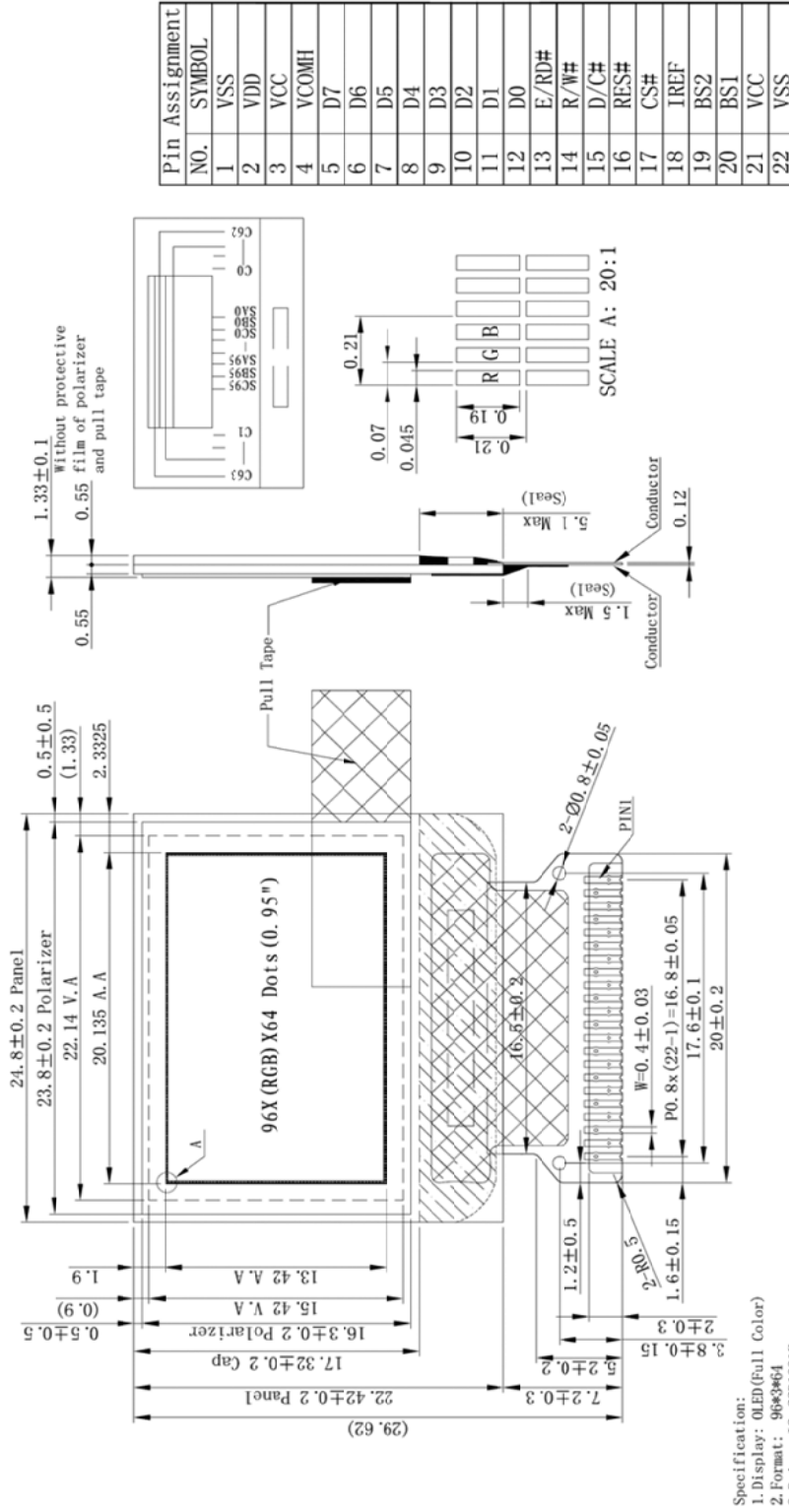

Specification:
 1. Display: OLED(Full Color)
 2. Format: 96*3*64
 3. Driver IC: SSD1331Z
 4. DUTY: 1/64
 5. Operate Temp: -30°C~70°C
 6. Storage Temp: -30°C~80°C
 7. RoHS Compliant

Drawing is deemed accurate but not guaranteed.

Part No.(s):	CFAL9664B-F-B2	Drawing Number:	CFAL9664B-F-B2	Hardware Rev.:	
Scale:	Not to scale	Units:	Millimeters	Date:	2016-02-24
Sheet:	1 of 1				





DETAILS OF INTERFACE PIN FUNCTIONS

PIN NO.	PIN NAME	DESCRIPTION												
1	VSS	Ground.												
2	VDD	Power Supply pin for logic operation of the driver.												
3	VCC	This is the most positive voltage supply pin of the chip.												
4	VCOMH	A capacitor should be connected between this pin and VSS.												
5~12	D7~D0	These are 8-bit bi-directional data bus to be connected to the microprocessor's data bus. When serial interface mode is selected, D0 will be the serial clock input, SCLK; D1 will be the serial data input: SDIN and D2 should be left opened.												
13	E/RD#	This pin is MCU interface input. When interfacing to a 6800-series microprocessor, this pin will be used as the Enable (E) signal. Read/write operation is initiated when this pin is pulled high and the chip is selected.												
14	R/W#	This pin is MCU interface input. When interfacing to a 6800-series microprocessor, this pin will be used as Read/Write (R/W) selection input. Read mode will be carried out when this pin is pulled high and write mode when low.												
15	D/C#	This pin is Data/Command control pin. When the pin is pulled high, the data at D7-D0 is treated as display data. When the pin is pulled low, the data at D7-D0 will be transferred to the command register.												
16	RES#	Reset pin, active low.												
17	CS#	Chip select pin, active low.												
18	IREF	A resistor should be connected between this pin and VSS.												
19	BS2	These are MCU interface input selection pins. See the following table for selecting different interfaces:												
20	BS1													
		<table border="1"> <thead> <tr> <th>Pin Name</th> <th>6800-parallel Interface</th> <th>8080-parallel interface</th> <th>Serial Interface</th> </tr> </thead> <tbody> <tr> <td>BS1</td> <td>0</td> <td>1</td> <td>0</td> </tr> <tr> <td>BS2</td> <td>1</td> <td>1</td> <td>0</td> </tr> </tbody> </table>	Pin Name	6800-parallel Interface	8080-parallel interface	Serial Interface	BS1	0	1	0	BS2	1	1	0
Pin Name	6800-parallel Interface	8080-parallel interface	Serial Interface											
BS1	0	1	0											
BS2	1	1	0											
21	VCC	This is the most positive voltage supply pin of the chip.												
22	VSS	Ground.												



BLOCK DIAGRAM

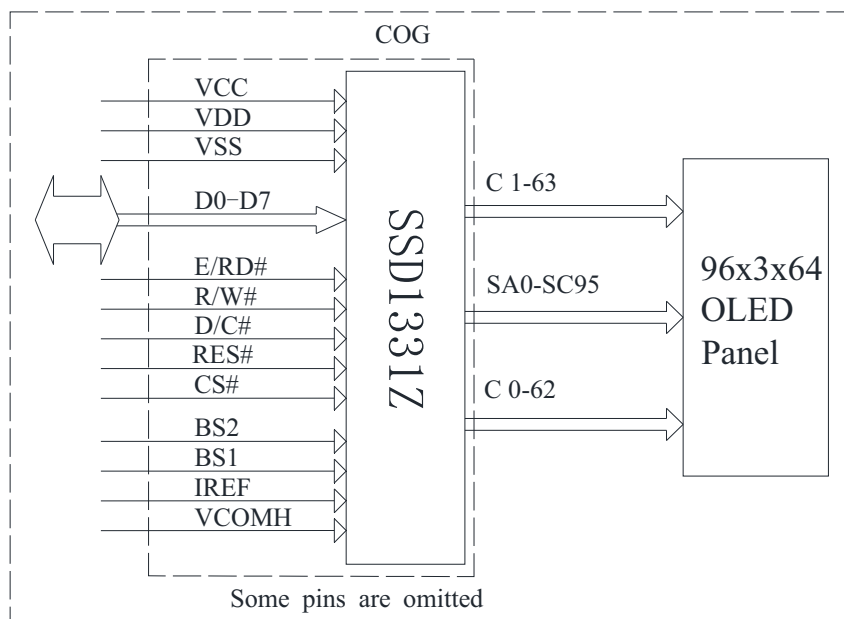

ELECTRICAL SPECIFICATIONS

ABSOLUTE MAXIMUM RATINGS

ITEM	SYMBOL	MIN	MAX	UNIT	REMARK
Logic supply voltage	VDD	-0.3	4	V	IC maximum rating
OLED Operating voltage	VCC	0	19	V	IC maximum rating
Operating Temp.	Top	-30	70	°C	-
Storage Temp	Tstg	-30	80	°C	-

Note (1): All of the voltages are on the basis of “VSS = 0V”.

Note (2): Permanent breakage of module may occur if the module is used beyond the maximum rating. The module can be normal operated under the conditions according to Section 8 “Electrical Characteristics”. Malfunctioning of the module may occur and the reliability of the module may deteriorate if the module is used beyond the conditions.



DC CHARACTERISTICS (3.3V OPERATION)

ITEM	SYMBOL	TEST CONDITION	MIN	TYP	MAX	UNIT
Logic Supply Voltage	VDD	22±3°C, 55±15%R.H	2.4	2.7	3.5	V
OLED Driver Supply Voltage	VCC	22±3°C, 55±15%R.H	9.5	10	10.5	V
High-level Input Voltage	V _{IH}	-	0.8×VDD	-	-	V
Low-level Input Voltage	V _{IL}	-	-	-	0.2×VDD	V
High-level Output Voltage	V _{OH}	-	0.9×VDD	-	VDD	V
Low-level Output Voltage	V _{OL}	-	-	-	0.1×VDD	V

Note : The VCC input must be kept in a stable value; ripple and noise are not allowed.



OPTICAL CHARACTERISTICS

ITEM	SYMBOL	TEST CONDITION	MIN	TYP	MAX	UNIT
Normal Mode Brightness	L_{br}	All pixels ON(1)	80	100	-	cd/m ²
Normal Mode Power Consumption	Pt	All pixels ON(1)	-	130	170	mW
Sleep mode VDD Current	I_{DD_SLEEP}	Display OFF, No panel attached	-	0	20	uA
Sleep mode VCC Current	I_{CC_SLEEP}	Display OFF, No panel attached	-	0	20	uA
C.I.E(White)	(x)	x,y(CIE1931)	0.26	0.30	0.34	-
	(y)		0.28	0.32	0.36	-
C.I.E(Red)	(x)	x,y(CIE1931)	0.61	0.65	0.69	-
	(y)		0.30	0.34	0.38	-
C.I.E(Green)	(x)	x,y(CIE1931)	0.25	0.29	0.33	-
	(y)		0.54	0.58	0.62	-
C.I.E(Blue)	(x)	x,y(CIE1931)	0.10	0.14	0.18	-
	(y)		0.12	0.16	0.20	-
Dark Room Contrast	CR	-	≥2000:1	-	-	-
Response Time	-	-	---	10	-	μ s
View Angle	-	-	≥160	-	-	Degree

Note(1): Normal Mode test conditions are as follows:

- Driving voltage :10V
- Contrast setting : R:0xc0 G:0x65 B:0x95
- Frame rate : 105Hz
- Duty setting : 1/64

ESD (ELECTRO-STATIC DISCHARGE) SPECIFICATIONS

The circuitry is industry standard CMOS logic and susceptible to ESD damage. Please use industry standard anti-static precautions as you would for any other static sensitive devices such as expansion cards, motherboards, or integrated circuits. Ground your body, work surfaces, and equipment.



AC CHARACTERISTICS

(1)6800-Series MPU Parallel Interface Timing Characteristics

(VDD - VSS = 2.4V to 3.5V, TA = 25°C)

Symbol	Parameter	Min	Typ	Max	Unit
t_{cycle}	Clock Cycle Time (write cycle)	130	-	-	ns
PW_{CSL}	Control Pulse Low Width (write cycle)	60	-	-	ns
PW_{CSH}	Control Pulse High Width (write cycle)	60	-	-	ns
t_{cycle}	Clock Cycle Time (read cycle)	200	-	-	ns
PW_{CSL}	Control Pulse Low Width (read cycle)	100	-	-	ns
PW_{CSH}	Control Pulse High Width (read cycle)	100	-	-	ns
t_{AS}	Address Setup Time	0	-	-	ns
t_{AH}	Address Hold Time	10	-	-	ns
t_{DSW}	Data Setup Time	40	-	-	ns
t_{DHW}	Data Hold Time	10	-	-	ns
t_{ACC}	Data Access Time	-	-	140	ns
t_{OH}	Output Hold time	-	-	70	ns
t_R	Rise Time	-	-	15	ns
t_F	Fall Time	-	-	15	ns

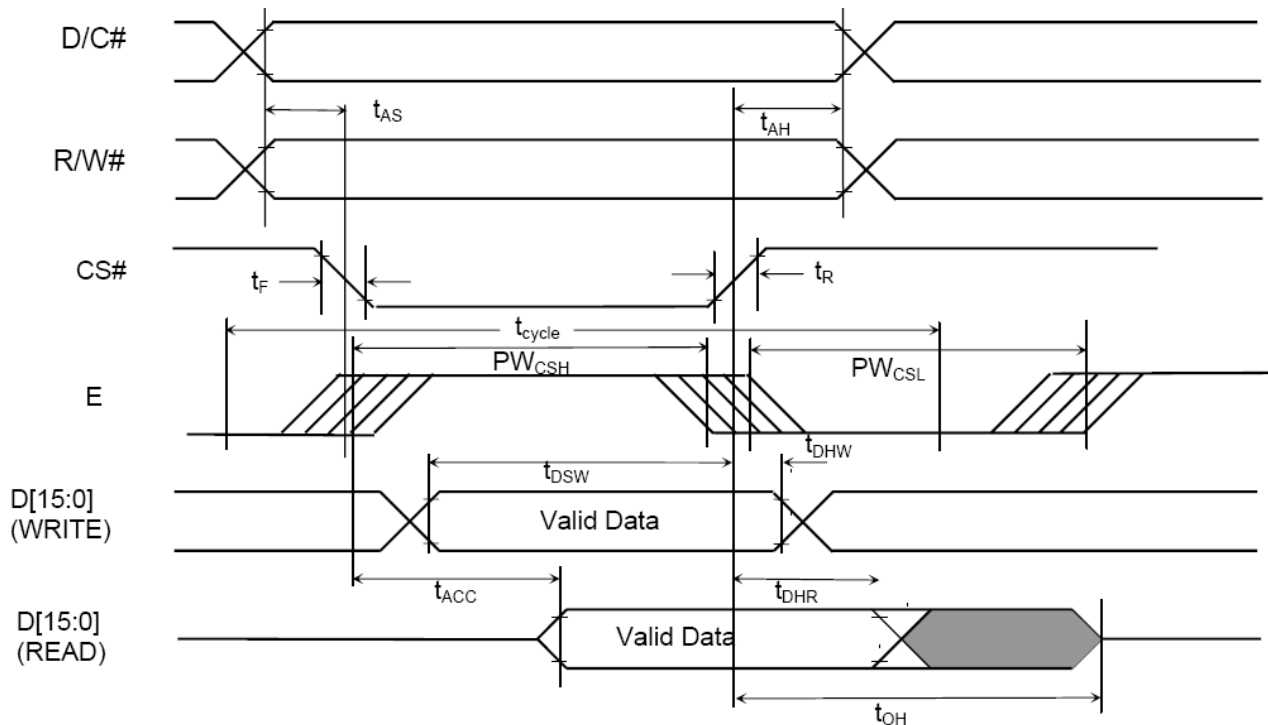

6800-series parallel interface characteristics



(2)8080-Series MPU Parallel Interface Timing Characteristics

(VDD - VSS = 2.4V to 3.5V, TA = 25°C)

Symbol	Parameter	Min	Typ	Max	Unit
t_{cycle}	Clock Cycle Time	130	-	-	ns
t_{AS}	Address Setup Time	10	-	-	ns
t_{AH}	Address Hold Time	0	-	-	ns
t_{DSW}	Write Data Setup Time	40	-	-	ns
t_{DHW}	Write Data Hold Time	10	-	-	ns
t_{DHR}	Read Data Hold Time	20	-	-	ns
t_{OH}	Output Disable Time	-	-	70	ns
t_{ACC}	Access Time	-	-	140	ns
t_{PWLR}	Read Low Time	150	-	-	ns
t_{PWLW}	Write Low Time	60	-	-	ns
t_{PWHR}	Read High Time	60	-	-	ns
t_{PWHW}	Write High Time	60	-	-	ns
t_R	Rise Time	-	-	15	ns
t_F	Fall Time	-	-	15	ns
t_{CS}	Chip select setup time	0	-	-	ns
t_{CSH}	Chip select hold time to read signal	0	-	-	ns
t_{CSF}	Chip select hold time	20	-	-	ns

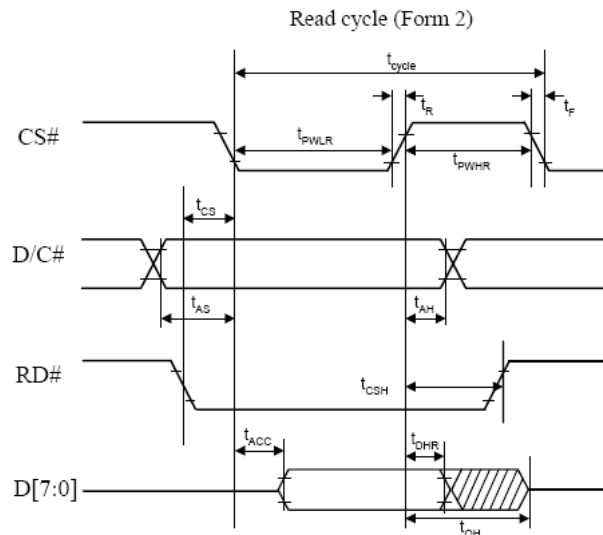
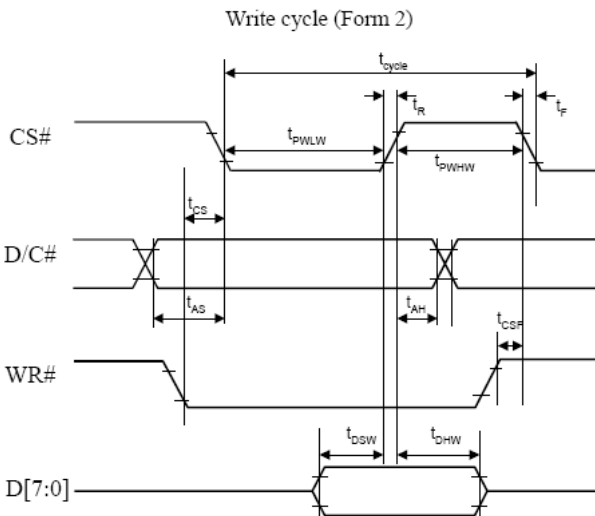
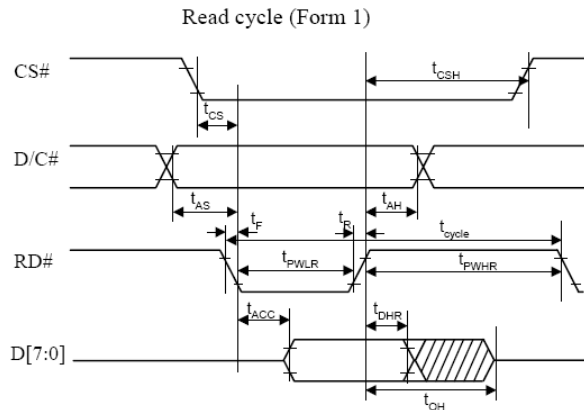
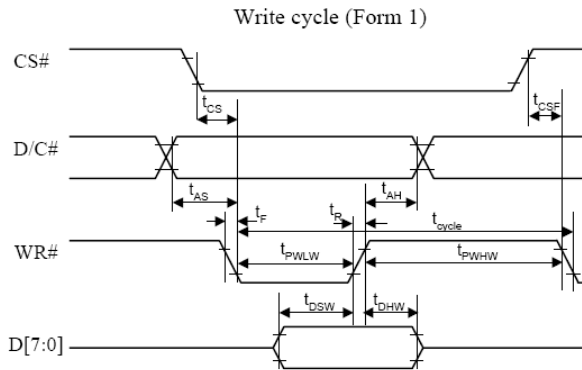

8080-series parallel interface characteristics



(3)-Serial Interface Timing Characteristics

(VDD - VSS = 2.4V to 3.5V, TA = 25°C)

Symbol	Parameter	Min	Typ	Max	Unit
t_{cycle}	Clock Cycle Time	150	-	-	ns
t_{AS}	Address Setup Time	40	-	-	ns
t_{AH}	Address Hold Time	40	-	-	ns
t_{CSS}	Chip Select Setup Time	75	-	-	ns
t_{CSH}	Chip Select Hold Time	60	-	-	ns
t_{DSW}	Write Data Setup Time	40	-	-	ns
t_{DHW}	Write Data Hold Time	40	-	-	ns
t_{CLKL}	Clock Low Time	75	-	-	ns
t_{CLKH}	Clock High Time	75	-	-	ns
t_R	Rise Time	-	-	15	ns
t_F	Fall Time	-	-	15	ns

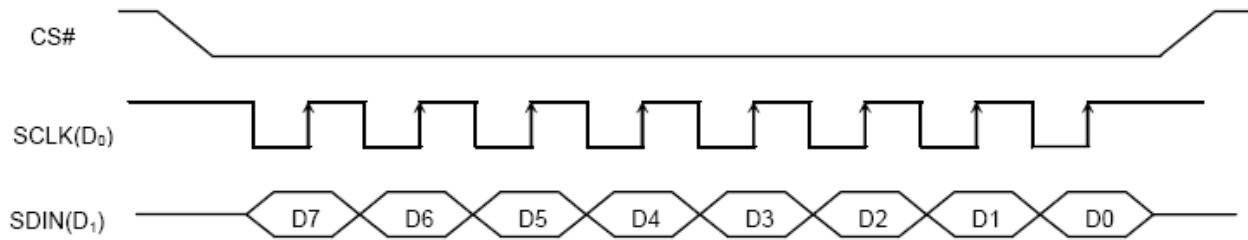
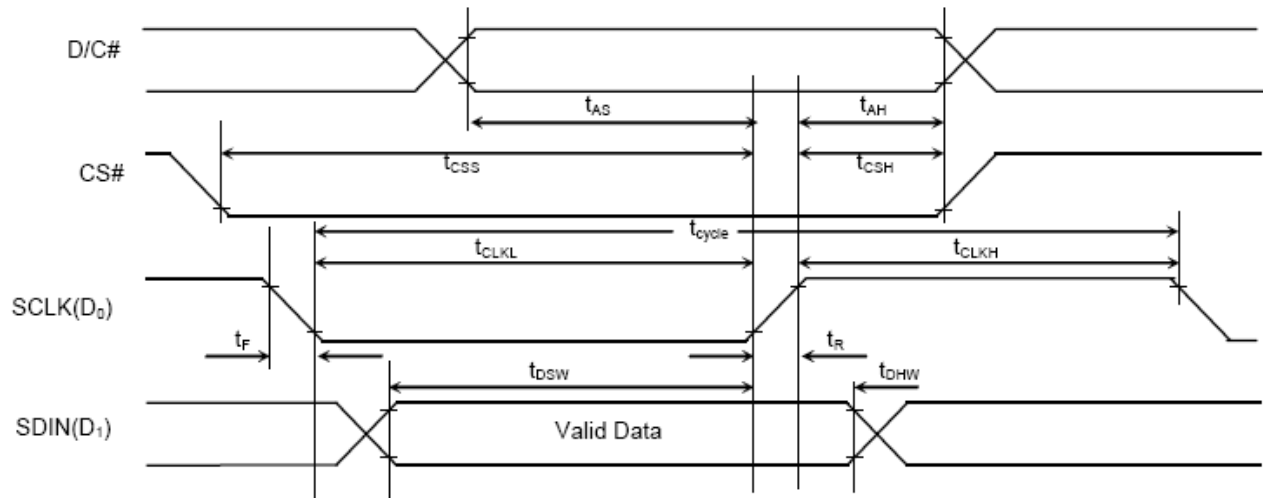

Serial interface characteristics



FUNCTIONAL SPECIFICATIONS AND APPLICATION CIRCUIT

POWER ON AND POWER OFF SEQUENCE

Power ON Sequence:

1. Power ON VDD.
2. After VDD become stable, set RES pin LOW (logic low) for at least 3us (t_1)⁽⁴⁾ and then HIGH (logic high).
3. After set RES# pin LOW (logic low), wait for at least 3us (t_2). Then Power ON VCC⁽¹⁾.
4. After VCC become stable, send command AFh for display ON. SEG/COM will be ON after 100ms(t_{AF}).

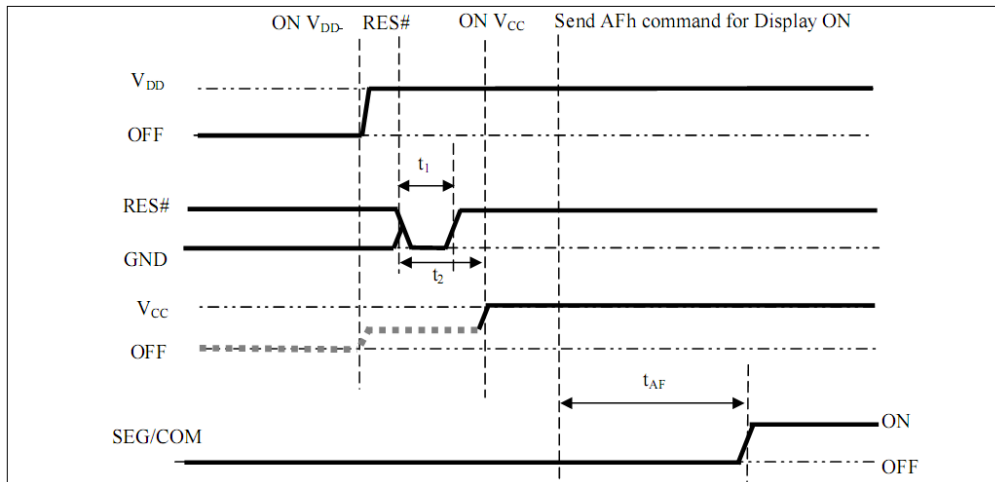

Power OFF Sequence:

1. Send command AEh for display OFF.
2. Power OFF VCC^{(1),(2),(3)}.
3. Power OFF VDD after t_{OFF} ⁽⁵⁾. (Typical t_{OFF} =100ms)

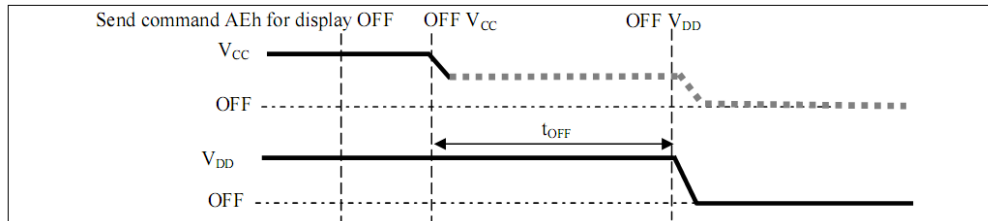

Note:

- (1) Since an ESD protection circuit is connected between VDD and VCC, VCC becomes lower than VDD whenever VDD is ON and VCC is OFF as shown in the dotted line of VCC in above figures.
- (2) VCC should be kept float (disable) when it is OFF.
- (3) Power Pins (VDD , VCC) can never be pulled to ground under any circumstance.
- (4) The register values are reset after t_1 .
- (5) VDD should not be Power OFF before VCC Power OFF.



APPLICATION CIRCUIT

(3).The configuration for SPI mode, external VCC is shown in the following diagram:

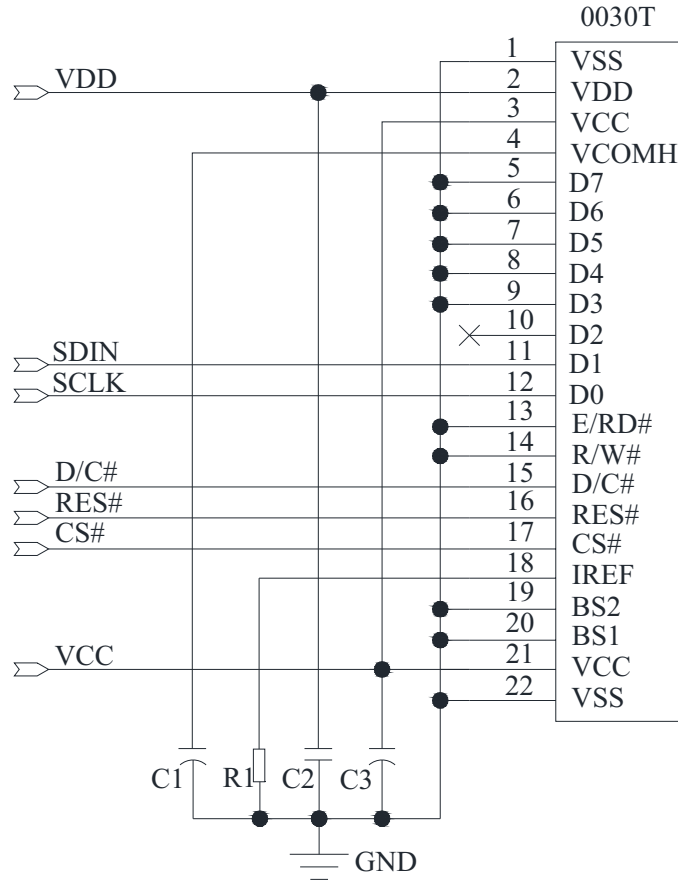

Pin connected to MCU interface: SCLK, SDIN, D/C#, RES#, CS#

Recommended components

C1, C3 4.7 μ F/25V.RoHS (Tantalum Capacitors)

C2: 0.1 μ F-0603-X7R \pm 10%.RoHS

R1: 0603 1/10W +/-5% 910Kohm.RoHS



EXAMPLE OF EXTERNAL DC-DC APPLICATION CIRCUIT

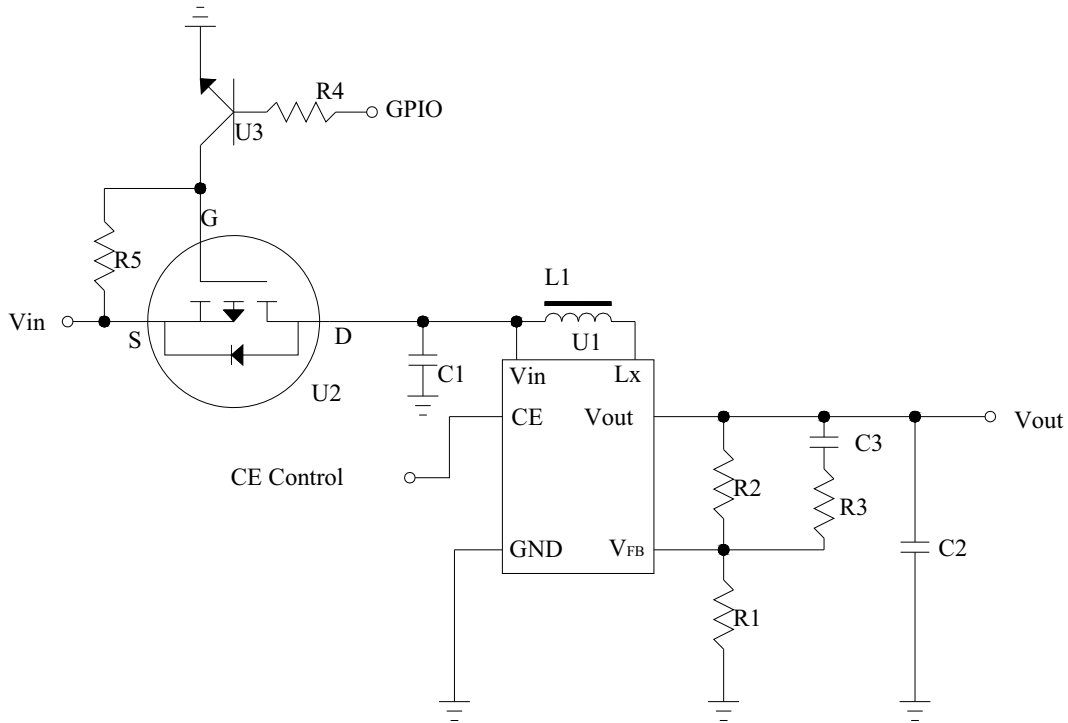

Recommend component

The C1	: 1 uF-0603-X7R±10%.RoHS
The C2	: 1 uF-0603-X7R±10%.RoHS
The C3	: 220pF-0603-X7R±10%.RoHS
The R1	: 0603 1/10W +/-5% 10Kohm.RoHS
The R2	: 0603 1/10W +/-1% 90Kohm.RoHS
The R3	: 0603 1/10W +/-5% 2Kohm.RoHS
The R4	: 0603 1/10W +/-5% 1Kohm.RoHS
The R5	: 0603 1/10W +/-5% 10Kohm.RoHS
The L1	: 22uH
The U1	: R1200
The U2	: FDN338P
The U3	: SS8050



MODULE RELIABILITY AND LONGEVITY

DISPLAY MODULE RELIABILITY TEST RESULTS

NO.	ITEM	CONDITION	QUANTITY
1	High Temperature (Non-operation)	80°C,240hrs	4
2	Low Temperature (Non-operation)	-30°C,240hrs	4
3	High Temperature (Operation)	70°C,240hrs	4
4	Low Temperature (Operation)	-30°C,240hrs	4
5	High Temperature / High Humidity (Operation)	60°C,90%RH,240hrs	4
6	Thermal shock (Non-operation)	-30°C~80°C(-30°C/30min;transit/3min;80°C/30min;transit/3min) 1 cycle: 66min,30cycles	4
7	ESD (Non-operation)	Air discharge model +/- 8kV Test nine dots and each dots should be discharged ten times and the interval time can't be less than one second.	4
8	Vibration	Frequency: 5~50Hz,0.5G Scan rate: 1 oct/min Time: 2 hrs/axis Test axis: X,Y, Z	1 Carton
9	Drop	Height: 100 cm Sequence: 1 angle, 3 edges and 6 faces	1 Carton

Test and measurement conditions

- All measurements shall not be started until the specimens attain to temperature stability, the stable time is at least 15 minutes.
- The degradation of polarizer is ignored for item 5.
- The tolerance of temperature is $\pm 3^{\circ}\text{C}$, and the tolerance of relative humidity is $\pm 5\%$.

Evaluation criteria

- The function test is OK.
- No observable defects.
- Luminance: $\geq 50\%$ of initial value.
- Current consumption: within $\pm 50\%$ of initial value.



MODULE RELIABILITY

ITEM	SPECIFICATION
CFAL9664B-F-B2	Brightness will be >50% of a new module's initial brightness for at least 10,000 hours of operation.
<i>Accelerated Test Conditions: 200 cd/m². Test pattern is 50% alternating checkerboard. 22±3°C, 55±15% RH</i>	

OLED displays are an emissive technology that is still evolving. Each pixel is susceptible to dimming (burn-in) based on its individual use. Burn-in happens when the same data is sent over and over to the display. Frequently used pixels dim more quickly than pixels that are not used as often. Please avoid a bright, static, high-contrast image that is displayed for a long time. If you want to leave the display powered on, use scrolling text or alternating images to "wear level" the pixels. The more you can vary the images, the better. To conserve power and display lifetime, turn off or dim the display when it is not in use.

MODULE LONGEVITY (EOL / REPLACEMENT POLICY)

CrystalFontz is committed to making all of our modules available for as long as possible. For each module we introduce, we intend to offer it indefinitely. We do not pre-plan a module's obsolescence. The majority of modules we have introduced are still available.

We recognize that discontinuing a module may cause problems for some customers. However, rapidly changing technologies, component availability, or low customer order levels may force us to discontinue ("End of Life", EOL) a module. For example, we must occasionally discontinue a module when a supplier discontinues a component or a manufacturing process becomes obsolete. When we discontinue a module, we will do our best to find an acceptable replacement module with the same fit, form, and function.

In most situations, you will not notice a difference when comparing a "fit, form, and function" replacement module to the discontinued module it replaces. However, sometimes a change in component or process for the replacement module results in a slight variation, perhaps an improvement, over the previous design.

Although the replacement module is still within the stated Datasheet specifications and tolerances of the discontinued module, changes may require modification to your circuit and/or firmware. Possible changes include:

- *Controller.* A new controller may require minor changes in your code.
- *Component tolerances.* Module components have manufacturing tolerances. In extreme cases, the tolerance stack can change the visual or operating characteristics.

Please understand that we avoid changing a module whenever possible; we only discontinue a module if we have no other option. We will post Part Change Notices on the product's web page as soon as possible. If interested, you can subscribe to future part change notifications.

SOURCES FOR DRIVER LIBRARIES

Driver libraries may save you a lot of time and help you develop a more professional product. Possible library sources are [easyGUI](#), [RAMTEX](#), [Micrium](#), and [Segger](#).