

CONTENTS

1. General Information	3
2. Module Description	4
3. CFAL1602C Series Variants	4
4. Features	4
5. Mechanical Data	5
6. Mechanical Drawing	6
7. Interface Pin Function	7
8. System Block Diagram	7
9. Absolute Maximum Ratings	8
10. Electrical Characteristics	8
11. Optical Characteristics	9
12. OLED Lifetime	11
13. Character Generator ROM (CGROM)	12
14. OLED Module Precautions	16

1. General Information

Datasheet Revision History

Datasheet Release: **2026-02-26**
Datasheet for the CFAL1602C Series OLED graphic display module.

Product Change Notifications

You can check for or subscribe to [Part Change Notices](#) for this display module on our website.

Variations

Slight variations between lots are normal (e.g., contrast, color, or intensity).

Volatility

This display module has volatile memory.

Disclaimer

Certain applications using CrystalFontz America, Inc. products may involve potential risks of death, personal injury, or severe property or environmental damage ("Critical Applications"). CRYSTALFONTZ AMERICA, INC. PRODUCTS ARE NOT DESIGNED, INTENDED, AUTHORIZED, OR WARRANTED TO BE SUITABLE FOR USE IN LIFE-SUPPORT APPLICATIONS, DEVICES OR SYSTEMS OR OTHER CRITICAL APPLICATIONS. Inclusion of CrystalFontz America, Inc. products in such applications is understood to be fully at the risk of the customer. In order to minimize risks associated with customer applications, adequate design and operating safeguards should be provided by the customer to minimize inherent or procedural hazard. Please contact us if you have any questions concerning potential risk applications.

CrystalFontz America, Inc. assumes no liability for applications assistance, customer product design, software performance, or infringements of patents or services described herein. Nor does CrystalFontz America, Inc. warrant or represent that any license, either express or implied, is granted under any patent right, copyright, or other intellectual property right of CrystalFontz America, Inc. covering or relating to any combination, machine, or process in which our products or services might be or are used.

All specifications in datasheets on our website are, to the best of our knowledge, accurate but not guaranteed. Corrections to specifications are made as any inaccuracies are discovered.

Company and product names mentioned in this publication are trademarks or registered trademarks of their respective owners.



Copyright © 2026 by CrystalFontz America, Inc., 12412 East Saltese Avenue, Spokane Valley, WA 99216 U.S.A.

2. Module Description

The CFAL1602C Series OLED character display modules have four-character sets built-in that are selectable using the command set of the built-in WS0010 controller; which reduces your adoption time of the CFAL1602C into your project.

Please see [Winstar Display WS0010 LCD Controller Datasheet](#) for further reference.

3. CFAL1602C Series Variants

Photo	Part Number	Sunlight Readable	Interface	Color Description	LEDs
	CFAL1602C-B	Possible	4-Bit or 8-Bit Parallel	Blue characters on black background.	Blue
	CFAL1602C-W	Possible	4-Bit or 8-Bit Parallel	Light characters on black background.	White
	CFAL1602C-PW		SPI		
	CFAL1602C-PY	Possible	SPI	Yellow characters on black background.	Yellow
	CFAL1602C-YT	Yes	4-Bit or 8-Bit Parallel		
	CFAL1602C-PYT		SPI		

4. Features

- 16*2 Dot Matrix
- Built-in Controller: WS0010 (or equivalent)
- 5V Power Supply
- 1/16 Duty
- Wide Viewing Angle
- Wide Operating Temperature: -40° to +80°C
- Interface: Varies by module

5. Mechanical Data

Item	Specification (mm)	Specification (inches, reference)
Module Dimensions	85.0 (W) x 36.0 (H) x 10(max) (D)	3.346 (W) x 1.417 (H) x 0.394 (max) (D)
Viewing Area	66.0 (W) x 16.0 (H)	2.598 (W) x 0.629 (H)
Active Area	56.95 (W) x 11.85 (H)	2.242 (W) x 0.467 (H)
Dot Pitch	0.60 (W) x 0.70 (H)	0.024 (W) x 0.028 (H)
Dot Size	0.55 (W) x 0.65 (H)	0.022 (W) x 0.026 (H)
Character Size	2.95 (W) x 5.55 (H)	0.116 (W) x 0.219 (H)
Character Pitch	3.60 (W) x 6.30 (H)	0.142 (W) x 0.248 (H)
Weight (Typical)	24 grams	0.85 ounces

6. Mechanical Drawing

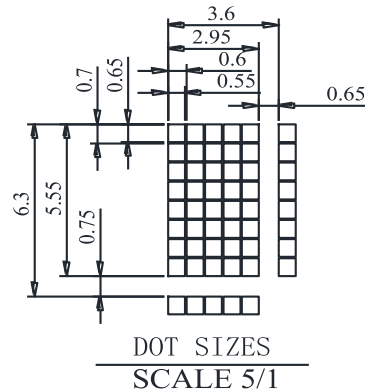
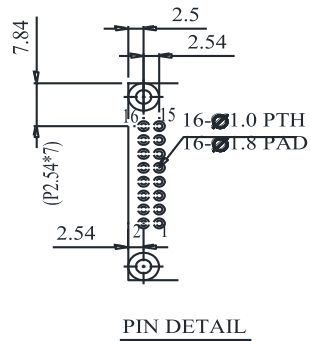
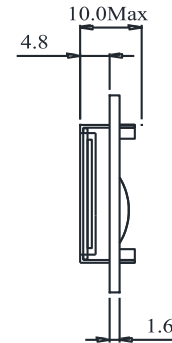
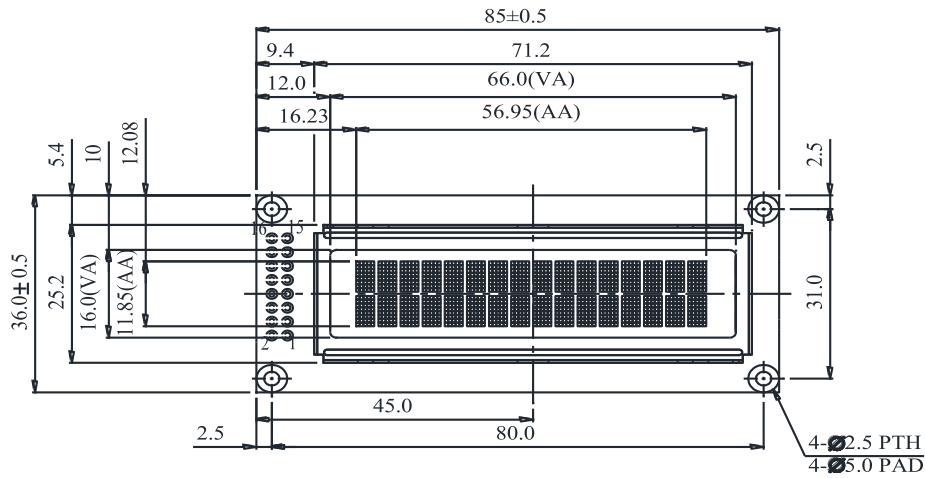

PIN NO.	SYMBOL
1	V _{ss}
2	V _{dd}
3	NC
4	RS
5	R/W
6	E
7	DB0
8	DB1
9	DB2
10	DB3
11	DB4
12	DB5
13	DB6
14	DB7
15	NC
16	NC

The non-specified tolerance of dimension is ±0.3 mm .

7. Interface Pin Function

Pin No.	Symbol	Level	Function
1	V _{SS}	0v	Ground
2	V _{DD}	5.0v	Supply Voltage for Logic
3	NC	-	No Connection
4	RS	H/L	H: Data L: Instruction Code
5	R/W	H/L	H: Read (Module → MPU) L: Write MPU (← Module)
6	E	H, H → L	Chip Enable Signal
7	DB0	H/L	Data Bus
8	DB1	H/L	Data Bus
9	DB2	H/L	Data Bus
10	DB3	H/L	Data Bus
11	DB4	H/L	Data Bus
12	-	H/L	Parallel Data Bus 5 / SPI: SCK
13	-	H/L	Parallel Data Bus 6 / SPI: MISO
14	-	H/L	Parallel Data Bus 7 / SPI: MOSI
15	NC	-	No Connection
16	NC	-	Parallel No Connection / SPI: SS

8. System Block Diagram

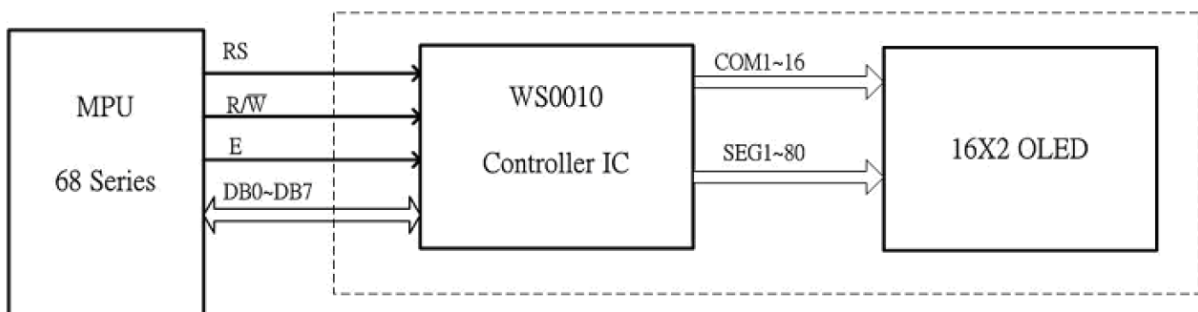

Address Format	DB7	DB6	DB5	DB4	DB3	DB2	DB1	DB0
CA (Character Address)	1	ADD6	ADD5	ADD4	ADD3	ADD2	ADD1	ADD0

1	2	3	4	13	14	15	16
CA10000000	CA10000001	CA10000010	CA10000011	CA10001100	CA10001101	CA10001110	CA10001111
CA11000000	CA11000001	CA11000010	CA11000011	CA11001100	CA11001101	CA11001110	CA11001111

9. Absolute Maximum Ratings

Parameter	Symbol	Min	Max	Unit	Notes
Supply Voltage for Logic	$V_{DD} - V_{SS}$	-0.3	5.3	V	(1)(2)
Operating Temperature	T_{OP}	-40	+80	°C	-
Storage Temperature	T_{ST}	-40	+80	°C	-

Notes:

- (1) These are stress ratings only. Extended exposure to the absolute maximum ratings listed above may affect device reliability or cause permanent damage.
- (2) Functional operation should be restricted to the limits in the Electrical Characteristics table below.

10. Electrical Characteristics

CFAL1602C-GT, CFAL1602C-PGT, CFAL1602C-YT, and CFAL1602C-PYT						
Item	Symbol	Condition	Min	Typ	Max	Unit
Supply Voltage for Logic	$V_{DD} - V_{SS}$	-	4.8	5.0	5.3	V
High-level Input	V_{IH}	-	0.8 V_{DD}	-	V_{DD}	V
Low-level Input	V_{IL}	-	GND	-	0.2 V_{DD}	V
High-level Output	V_{OH}	$I_{OH} = 0.5 \text{ mA}$	0.8 V_{DD}	-	V_{DD}	V
Low-level Output	V_{OL}	$I_{OL} = 0.5 \text{ mA}$	GND	-	0.2 V_{DD}	V
Supply Current	I_{DD}	$V_{DD} = 5\text{v}$	37	44	52	mA

CFAL1602C-B, CFAL1602C-PB, CFAL1602C-G, CFAL1602C-PG, CFAL1602C-R, CFAL1602C-PR, CFAL1602C-W, CFAL1602C-PW, CFAL1602C-Y, and CFAL1602C-PY						
Item	Symbol	Condition	Min	Typ	Max	Unit
Supply Voltage for Logic	$V_{DD} - V_{SS}$	-	4.8	5.0	5.3	V
High-level Input	V_{IH}	-	0.8 V_{DD}	-	V_{DD}	V
Low-level Input	V_{IL}	-	GND	-	0.2 V_{DD}	V
High-level Output	V_{OH}	$I_{OH} = 0.5 \text{ mA}$	0.8 V_{DD}	-	V_{DD}	V
Low-level Output	V_{OL}	$I_{OL} = 0.5 \text{ mA}$	GND	-	0.2 V_{DD}	V
Supply Current	I_{DD}	$V_{DD} = 5\text{v}$	30	35	42	mA

11. Optical Characteristics

CFAL1602C-B and CFAL1602C-PB						
Item	Symbol	Condition	Min	Typ	Max	Unit
View Angle	(V) θ	-	160	-	-	deg
	(H) ϕ	-	160	-	-	
Contrast Ratio	CR	Dark	2000:1	-	-	deg
Response Time	T rise	-	-	10	-	μ s
	T fall			10		
Display with 50% Check Board Brightness			60	70	-	cd/m ²
CIEx (Blue)		(CIE1931)	0.12	0.16	0.20	-
CIEy (Blue)		(CIE1931)	0.19	0.23	0.27	-

CFAL1602C-G and CFAL1602C-PG						
Item	Symbol	Condition	Min	Typ	Max	Unit
View Angle	(V) θ	-	160	-	-	deg
	(H) ϕ	-	160	-	-	
Contrast Ratio	CR	Dark	2000:1	-	-	deg
Response Time	T rise	-	-	10	-	μ s
	T fall			10		
Display with 50% Check Board Brightness			120	150	-	cd/m ²
CIEx (Green)		(CIE1931)	0.24	0.28	0.32	-
CIEy (Green)		(CIE1931)	0.59	0.63	0.67	-

CFAL1602C-GT and CFAL1602C-PGT						
Item	Symbol	Condition	Min	Typ	Max	Unit
View Angle	(V) θ	-	160	-	-	deg
	(H) ϕ	-	160	-	-	
Contrast Ratio	CR	Dark	2000:1	-	-	deg
Response Time	T rise	-	-	10	-	μ s
	T fall			10		
Display with 50% Check Board Brightness			120	150	-	cd/m ²
CIEx (Green)		(CIE1931)	0.24	0.28	0.32	-
CIEy (Green)		(CIE1931)	0.59	0.63	0.67	-

CFAL1602C-R and CFAL1602C-PR						
Item	Symbol	Condition	Min	Typ	Max	Unit
View Angle	(V) θ	-	160	-	-	deg
	(H) ϕ	-	160	-	-	
Contrast Ratio	CR	Dark	2000:1	-	-	deg
Response Time	T rise	-	-	10	-	μ s
	T fall			10		
Display with 50% Check Board Brightness			50	60	-	cd/m ²
CIEx (Red)		(CIE1931)	0.63	0.67	0.71	-
CIEy (Red)		(CIE1931)	0.29	0.33	0.37	-

CFAL1602C-W and CFAL1602C-PW						
Item	Symbol	Condition	Min	Typ	Max	Unit
View Angle	(V) θ	-	160	-	-	deg
	(H) ϕ	-	160	-	-	
Contrast Ratio	CR	Dark	2000:1	-	-	deg
Response Time	T rise	-	-	10	-	μ s
	T fall			10		
Display with 50% Check Board Brightness			50	60	-	cd/m ²
CIEx (White)		(CIE1931)	0.26	0.28	0.30	-
CIEy (White)		(CIE1931)	0.30	0.32	0.34	-

CFAL1602C-Y and CFAL1602C-PY						
Item	Symbol	Condition	Min	Typ	Max	Unit
View Angle	(V) θ	-	160	-	-	deg
	(H) ϕ	-	160	-	-	
Contrast Ratio	CR	Dark	2000:1	-	-	deg
Response Time	T rise	-	-	10	-	μ s
	T fall			10		
Display with 50% Check Board Brightness			100	120	-	cd/m ²
CIEx (Yellow)		(CIE1931)	0.45	0.47	0.49	-
CIEy (Yellow)		(CIE1931)	0.48	0.50	0.52	-

CFAL1602C-YT and CFAL1602C-PYT						
Item	Symbol	Condition	Min	Typ	Max	Unit
View Angle	(V) θ	-	160	-	-	deg
	(H) ϕ	-	160	-	-	
Contrast Ratio	CR	Dark	2000:1	-	-	deg
Response Time	T rise	-	-	10	-	μ s
	T fall			10		
Display with 50% Check Board Brightness			120	150	-	cd/m ²
CIEx (Yellow)		(CIE1931)	0.45	0.47	0.49	-
CIEy (Yellow)		(CIE1931)	0.48	0.50	0.52	-

12. OLED Lifetime

Item	Conditions	Min	Typ	Notes
Operating Lifetime	T _a =25°C Initial 50% check board brightness Typical Value	40,000 Hrs	50,000 Hrs	(1)(2)(3)

Notes:

- (1) Lifetime is defined as the amount of time when the luminance has decayed to <50% of the initial value.
- (2) This analysis method uses life data obtained under accelerated conditions to extrapolate an estimated Probability Density Function (PDF) for the product under normal use conditions.
- (3) Screen saving mode will extend OLED lifetime.

13. Character Generator ROM (CGROM)

English and Japanese Character Font Set

Upper 4bit / Lower 4bit	LLLL	LLLH	LLHL	LLHH	LHLL	LHLH	LHHL	LHHH	HLLL	HLLH	HLHL	HLHH	HHLL	HHLH	HHHL	HHHH
LLLL	CG RAM (1)	☺	☹	☺	☹	☺	☹	☺	☹	☺	☹	☺	☹	☺	☹	☺
LLLL	CG RAM (2)	☺	☹	☺	☹	☺	☹	☺	☹	☺	☹	☺	☹	☺	☹	☺
LLHL	CG RAM (3)	☺	☹	☺	☹	☺	☹	☺	☹	☺	☹	☺	☹	☺	☹	☺
LLHH	CG RAM (4)	☺	☹	☺	☹	☺	☹	☺	☹	☺	☹	☺	☹	☺	☹	☺
LHLL	CG RAM (5)	☺	☹	☺	☹	☺	☹	☺	☹	☺	☹	☺	☹	☺	☹	☺
LHLH	CG RAM (6)	☺	☹	☺	☹	☺	☹	☺	☹	☺	☹	☺	☹	☺	☹	☺
LHHL	CG RAM (7)	☺	☹	☺	☹	☺	☹	☺	☹	☺	☹	☺	☹	☺	☹	☺
LHHH	CG RAM (8)	☺	☹	☺	☹	☺	☹	☺	☹	☺	☹	☺	☹	☺	☹	☺
HLLL	CG RAM (9)	☺	☹	☺	☹	☺	☹	☺	☹	☺	☹	☺	☹	☺	☹	☺
HLLH	CG RAM (10)	☺	☹	☺	☹	☺	☹	☺	☹	☺	☹	☺	☹	☺	☹	☺
HLHL	CG RAM (11)	☺	☹	☺	☹	☺	☹	☺	☹	☺	☹	☺	☹	☺	☹	☺
HLHH	CG RAM (12)	☺	☹	☺	☹	☺	☹	☺	☹	☺	☹	☺	☹	☺	☹	☺
HHLL	CG RAM (13)	☺	☹	☺	☹	☺	☹	☺	☹	☺	☹	☺	☹	☺	☹	☺
HHLH	CG RAM (14)	☺	☹	☺	☹	☺	☹	☺	☹	☺	☹	☺	☹	☺	☹	☺
HHHL	CG RAM (15)	☺	☹	☺	☹	☺	☹	☺	☹	☺	☹	☺	☹	☺	☹	☺
HHHH	CG RAM (16)	☺	☹	☺	☹	☺	☹	☺	☹	☺	☹	☺	☹	☺	☹	☺

Western European Character Font Set 1

Upper 4bit / Lower 4bit	LLLL	LLLN	LLHL	LLHH	LHLL	LHLN	LHHL	LHNN	HLLL	HLLN	HLHL	HLNN	HNLL	HNLN	HNHL	HNHN
LLLL (CG RAM 1)	CG RAM (1)			0	1	2	3	4	5	6	7	8	9	A	B	C
LLLL (CG RAM 2)	CG RAM (2)		!	1	2	3	4	5	6	7	8	9	A	B	C	D
LLHL (CG RAM 3)	CG RAM (3)		"	2	3	4	5	6	7	8	9	A	B	C	D	E
LLHN (CG RAM 4)	CG RAM (4)		#	3	4	5	6	7	8	9	A	B	C	D	E	F
LHLL (CG RAM 5)	CG RAM (5)		\$	4	5	6	7	8	9	A	B	C	D	E	F	G
LHLN (CG RAM 6)	CG RAM (6)		%	5	6	7	8	9	A	B	C	D	E	F	G	H
LHHL (CG RAM 7)	CG RAM (7)		&	6	7	8	9	A	B	C	D	E	F	G	H	I
LHNN (CG RAM 8)	CG RAM (8)		'	7	8	9	A	B	C	D	E	F	G	H	I	J
HLLL (CG RAM 9)	CG RAM (9)		(8	9	A	B	C	D	E	F	G	H	I	J	K
HLLN (CG RAM 10)	CG RAM (10))	9	A	B	C	D	E	F	G	H	I	J	K	L
HLHL (CG RAM 11)	CG RAM (11)		*	A	B	C	D	E	F	G	H	I	J	K	L	M
HLNN (CG RAM 12)	CG RAM (12)		+	B	C	D	E	F	G	H	I	J	K	L	M	N
HNLL (CG RAM 13)	CG RAM (13)		,	C	D	E	F	G	H	I	J	K	L	M	N	O
HNLN (CG RAM 14)	CG RAM (14)		-	D	E	F	G	H	I	J	K	L	M	N	O	P
HNHL (CG RAM 15)	CG RAM (15)		.	E	F	G	H	I	J	K	L	M	N	O	P	Q
HNHN (CG RAM 16)	CG RAM (16)		/	F	G	H	I	J	K	L	M	N	O	P	Q	R

English Russian Character Font Set

Upper 4bit	LLLL	LLLH	LLHL	LLHH	LHLL	LHLH	LHHL	LHHH	HLLL	HLLH	HLHL	HLHH	HHLL	HHLH	HHHL	HHHH
LLLL	CG RAM (1)	А	В	С	Д	Е	Ж	З	И	Й	К	Л	М	Н	О	П
LLLL	CG RAM (2)	а	б	в	г	д	е	ё	ж	з	и	й	к	л	м	н
LLHL	CG RAM (3)	А	В	С	Д	Е	Ж	З	И	Й	К	Л	М	Н	О	П
LLHH	CG RAM (4)	а	б	в	г	д	е	ё	ж	з	и	й	к	л	м	н
LHLL	CG RAM (5)	А	В	С	Д	Е	Ж	З	И	Й	К	Л	М	Н	О	П
LHLH	CG RAM (6)	а	б	в	г	д	е	ё	ж	з	и	й	к	л	м	н
LHHL	CG RAM (7)	А	В	С	Д	Е	Ж	З	И	Й	К	Л	М	Н	О	П
LHHH	CG RAM (8)	а	б	в	г	д	е	ё	ж	з	и	й	к	л	м	н
HLLL	CG RAM (9)	А	В	С	Д	Е	Ж	З	И	Й	К	Л	М	Н	О	П
HLLH	CG RAM (10)	а	б	в	г	д	е	ё	ж	з	и	й	к	л	м	н
HLHL	CG RAM (11)	А	В	С	Д	Е	Ж	З	И	Й	К	Л	М	Н	О	П
HLHH	CG RAM (12)	а	б	в	г	д	е	ё	ж	з	и	й	к	л	м	н
HHLL	CG RAM (13)	А	В	С	Д	Е	Ж	З	И	Й	К	Л	М	Н	О	П
HHLH	CG RAM (14)	а	б	в	г	д	е	ё	ж	з	и	й	к	л	м	н
HHHL	CG RAM (15)	А	В	С	Д	Е	Ж	З	И	Й	К	Л	М	Н	О	П
HHHH	CG RAM (16)	а	б	в	г	д	е	ё	ж	з	и	й	к	л	м	н

Western European Character Font Set II

Upper 4bit Lower 4bit	LLLL	LLLH	LLHL	LLHH	LHLL	LHLH	LHHL	LHHH	HLLL	HLLH	HLHL	HLHH	HHLL	HHLH	HHHL	HHHH
LLLL	CG RAM (1)	±	⊗	⊙	⊕	⊖	⊗	⊙	⊕	⊖	⊗	⊙	⊕	⊖	⊗	⊙
LLLL	CG RAM (2)	≡	!	1	∞	∞	∞	∞	∞	∞	∞	∞	∞	∞	∞	∞
LLHL	CG RAM (3)	∞	"	2	B	R	b	r	E	e	S	s	∞	∞	∞	∞
LLHH	CG RAM (4)	∞	#	3	C	S	c	S	S	S	∞	∞	∞	∞	∞	∞
LHLL	CG RAM (5)	∞	4	D	T	d	t	S	S	∞	∞	∞	∞	∞	∞	∞
LHLH	CG RAM (6)	∞	5	E	U	e	u	S	S	∞	∞	∞	∞	∞	∞	∞
LHHL	CG RAM (7)	∞	6	F	U	f	u	S	S	∞	∞	∞	∞	∞	∞	∞
LHHH	CG RAM (8)	∞	7	G	W	g	w	S	S	∞	∞	∞	∞	∞	∞	∞
HLLL	CG RAM (9)	∞	8	H	h	∞	∞	∞	∞	∞	∞	∞	∞	∞	∞	∞
HLLH	CG RAM (10)	∞	9	I	Y	i	y	∞	∞	∞	∞	∞	∞	∞	∞	∞
HLHL	CG RAM (11)	∞	∞	J	Z	j	z	∞	∞	∞	∞	∞	∞	∞	∞	∞
HLHH	CG RAM (12)	∞	∞	K	k	∞	∞	∞	∞	∞	∞	∞	∞	∞	∞	∞
HHLL	CG RAM (13)	∞	∞	L	l	∞	∞	∞	∞	∞	∞	∞	∞	∞	∞	∞
HHLH	CG RAM (14)	∞	∞	M	m	∞	∞	∞	∞	∞	∞	∞	∞	∞	∞	∞
HHHL	CG RAM (15)	∞	∞	N	n	∞	∞	∞	∞	∞	∞	∞	∞	∞	∞	∞
HHHH	CG RAM (16)	∞	∞	O	o	∞	∞	∞	∞	∞	∞	∞	∞	∞	∞	∞

14. OLED Module Precautions

The precautions below should be followed when using OLED modules to help ensure personal safety, module performance, and compliance of environmental regulations.

14.1. Modules

- Avoid applying excessive shocks to module or making any alterations or modifications to it.
- Do not make extra holes on the printed circuit board, modify its shape or change the components of OLED display module.
- Do not disassemble the OLED display module.
- Do not operate the OLED display module above the absolute maximum rating.
- Do not drop, bend or twist the OLED display module.
- Soldering: only to the I/O terminals.
- Store in an anti-static electricity container and clean environment.
- It is common to use the "screen saver" to extend the lifetime of the OLED display module.
 - Do not use the fixed information for long periods of time in real application.
 - Do not use fixed information in OLED panel for long periods of time to extend "screen burn" effect time.
- Crystalfontz has the right to change the passive components, including R2 and R3 adjust resistors. (Resistors, capacitors and other passive components will have different appearance and color caused by the different supplier.)
- Crystalfontz have the right to change the PCB Rev. (In order to satisfy the supplying stability, management optimization and the best product performance, etc., under the premise of not affecting the electrical characteristics and external dimensions, Crystalfontz has the right to modify the version.)

14.2. Handling Precautions

- Since the display panel is made of glass, do not apply mechanical impacts such as dropping from a high position.
- If the display panel is accidentally broken, and the internal organic substance leaks out, be careful not to inhale or touch the organic substance.
- If pressure is applied to the display surface or its neighborhood of the OLED display module, the cell structure may be damaged, so be careful not to apply pressure to these sections.
- The polarizer covering the surface of the OLED display module is soft and can be easily scratched. Please be careful when handling the OLED display module.
- Clean the surface of the polarizer covering the OLED display module if it becomes soiled using following adhesion tape.
 - Scotch Mending Tape No. 810 or an equivalent
 - Never breathe the soiled surface or wipe the surface using a cloth containing solvent such as ethyl alcohol, since the surface of the polarizer will become cloudy.
 - The following liquids/solvents may spoil the polarizer:
 - Water
 - Ketone
 - Aromatic Solvents
- Hold the OLED display module very carefully when placing the OLED display module into the system housing.
- Do not apply excessive stress or pressure to the OLED display module. And, do not over bend the film with electrode pattern layouts. These stresses will influence the display performance. Also, be sure to secure the sufficient rigidity for the outer cases.

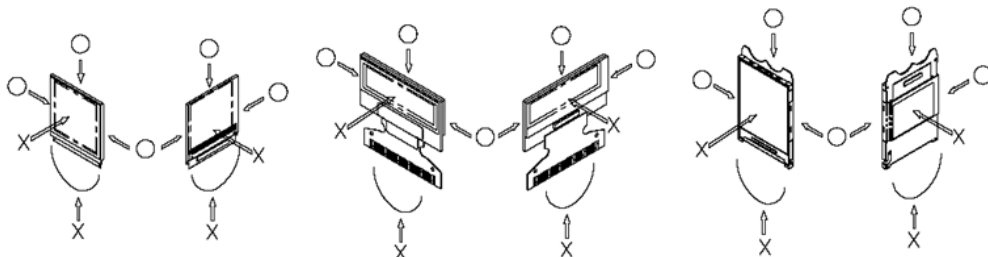



- Do not apply stress to the LSI chips and the surrounding molded sections.
- Do not disassemble or modify the OLED display module.
- Do not apply input signals while the logic power is off.
- Pay sufficient attention to the working environments when handling the OLED display module to prevent occurrence of element breakage accidents by static electricity.
 - Be sure to make human body grounding when handling OLED display modules.
 - Be sure to ground tools to use for assembly such as soldering irons.
 - To suppress generation of static electricity, avoid carrying out assembly work under dry environments.
 - Protective film is being applied to the surface of the display panel of the OLED display module. Be careful since static electricity may be generated when exfoliating the protective film.
- Protection film is being applied to the surface of the display panel and removes the protection film before assembling it. At this time, if the OLED display module has been stored for a long period of time, residue adhesive material of the protection film may remain on the surface of the display panel after the film has been removed. In such a case, remove the residue material by the method discussed above.
- If electric current is applied when the OLED display module is being dewed or when it is placed under high humidity environments, the electrodes may become corroded. If this happens proceed with caution when handling the OLED display module.

14.3. Storage Precautions

- When storing the OLED display modules put them in static electricity preventive bags to avoid exposure to direct sunlight and fluorescent lamps. Also avoid high temperature and high humidity environments and low temperatures (less than 0°C) environments. (We recommend you store these modules in the packaged state when they were shipped from Crystalfontz). Be careful not to let water drops adhere to the packages or bags, and do not let dew gather on them.
- If electric current is applied when water drops are adhering to the surface of the OLED display module the OLED display module may have become dewed. If a dewed OLED display module is placed under high humidity environments it may cause the electrodes to become corroded. If this happens proceed with caution when handling the OLED display module.

14.4. Designing Precautions

- The absolute maximum ratings are the ratings that cannot be exceeded for OLED display module. If these values are exceeded, panel damage may happen.
- To prevent occurrence of malfunctioning by noise pay attention to satisfy the V_{IL} and V_{IH} specifications and, at the same time, to make the signal line cable as short as possible.
- We recommend that you install excess current preventive unit (fuses, etc.) to the power circuit (V_{DD}). (Recommend value: 0.5A)
- Pay sufficient attention to avoid occurrence of mutual noise interference with the neighboring devices.
- As for EMI, take necessary measures on the equipment side.
- When fastening the OLED display module, fasten the external plastic housing section.
- If the power supply to the OLED display module is forcibly shut down, by such errors as taking out the main battery while the OLED display panel is in operation, we cannot guarantee the quality of this OLED display module.
 - Connection (contact) to any other potential than the above may lead to rupture of the IC.

14.5. Disposing Precautions

- Request the qualified companies to handle the industrial wastes when disposing of the OLED display modules. Or, when burning them, be sure to observe the environmental and hygienic laws and regulations.

14.6. Other Precautions

- When an OLED display module is operated for a long period of time with a fixed pattern, the fixed pattern may remain as an after image or a slight contrast deviation may occur.
 - If the operation is interrupted and left unused for a while, normal state can be restored.
 - This will not cause a problem in the reliability of the module.



- To protect the OLED display module from performance drops by static electricity rapture, etc., do not touch the following sections whenever possible while handling the OLED display modules.
 - Pins and electrodes
 - Pattern layouts such as the TCP & FPC
- With this OLED display module, the OLED driver is being exposed. Generally speaking, semiconductor elements change their characteristics when light is radiated according to the principle of the solar battery. Consequently, if this OLED driver is exposed to light, malfunctioning may occur.
 - Design the product and installation method so that the OLED driver may be shielded from light in actual usage.
 - Design the product and installation method so that the OLED driver may be shielded from light during the inspection processes.
- Although this OLED display module stores the operation state data by the commands and the indication data, when excessive external noise, etc. enters into the module, the internal status may be changed. Therefore, it is necessary to take appropriate measures to suppress noise generation or to protect from influences of noise on the system design.
- We recommend that you construct its software to make periodical refreshment of the operation statuses (re-setting of the commands and re-transference of the display data), to cope with catastrophic noise.
- Resistors, capacitors, and other passive components will have different appearance and color caused by the different supplier.
- Crystalfontz has the right to upgrade and modify the product function.
- The limitation of FPC bending:

