



TFT GRAPHIC DISPLAY MODULE WITH  
GRAPHIC ACCELERATOR BOARD  
DATASHEET



Datasheet Release Date 2021-07-06  
for  
**CFAF800480E1-050SC-A2**

**Crystalfontz America, Inc.**

12412 East Saltese Avenue  
Spokane Valley, WA 99216-0357  
Phone: 888-206-9720  
Fax: 509-892-1203  
Email: [support@crystalfontz.com](mailto:support@crystalfontz.com)  
URL: [www.crystalfontz.com](http://www.crystalfontz.com)



## CONTENTS

1. General Information .....	3
2. Introduction .....	4
3. Module Information .....	5
4. Features .....	5
4.1. TFT Display Module Features .....	5
4.2. EVE Graphics Accelerator Features .....	5
4.3. Module Information .....	5
4.4. Embedded Video Engine Documentation / Resources .....	5
4.5. Embedded Video Engine Programmer's Model .....	6
5. Mechanical Data .....	6
6. Mechanical Drawing .....	7
7. Interface Pin Function .....	8
8. Absolute Maximum Ratings .....	9
9. TFT Electrical Characteristics .....	9
10. Optical Characteristics .....	9
11. Backlight Characteristics .....	9
12. Getting Started .....	10
12.1. Getting Started with your CFAF800480E1-050SC-A1-2 .....	11
12.2. Getting started with the CFAF800480E1-050SC-A1-1 and a Windows PC .....	11
12.3. Getting started, hardware, with CFAF800480E1-050SC-A1-1 and your PCB .....	12
12.4. Troubleshooting .....	12
13. Care and Handling Precautions .....	13
13.1. ESD (Electrostatic Discharge) .....	13
13.2. Design and Mounting .....	13
13.3. Mechanical Shock, Impact, Torque, or Tension .....	13
13.4. LCD Panel Breakage .....	13
13.5. Cleaning .....	13
13.6. Operation .....	13
13.7. Storage and Recycling .....	14



## 1. General Information

### Datasheet Revision History

Datasheet Release: 2021-07-06  
Datasheet for the CFAF800480E1-050SC-A2 TFT graphic display module.

### Product Change Notifications

You can check for or subscribe to [Part Change Notices](#) for this display module on our website.

### Variations

Slight variations between lots are normal (e.g., contrast, color, or intensity).

### Volatility

This display module has volatile memory.

### Disclaimer

Certain applications using Crystalfontz America, Inc. products may involve potential risks of death, personal injury, or severe property or environmental damage ("Critical Applications"). CRYSTALFONTZ AMERICA, INC. PRODUCTS ARE NOT DESIGNED, INTENDED, AUTHORIZED, OR WARRANTED TO BE SUITABLE FOR USE IN LIFE-SUPPORT APPLICATIONS, DEVICES OR SYSTEMS OR OTHER CRITICAL APPLICATIONS. Inclusion of Crystalfontz America, Inc. products in such applications is understood to be fully at the risk of the customer. In order to minimize risks associated with customer applications, adequate design and operating safeguards should be provided by the customer to minimize inherent or procedural hazard. Please contact us if you have any questions concerning potential risk applications.

Crystalfontz America, Inc. assumes no liability for applications assistance, customer product design, software performance, or infringements of patents or services described herein. Nor does Crystalfontz America, Inc. warrant or represent that any license, either express or implied, is granted under any patent right, copyright, or other intellectual property right of Crystalfontz America, Inc. covering or relating to any combination, machine, or process in which our products or services might be or are used.

All specifications in datasheets on our website are, to the best of our knowledge, accurate but not guaranteed. Corrections to specifications are made as any inaccuracies are discovered.

Company and product names mentioned in this publication are trademarks or registered trademarks of their respective owners.

Copyright © 2021 by Crystalfontz America, Inc., 12412 East Saltese Avenue, Spokane Valley, WA 99216 U.S.A.



## 2. Introduction

The CFAF800480E1-050SC-A2 is an accelerated display module for embedded systems. It centers around the FTDI/BridgeTek BT817 EVE4 (Embedded Video Engine) graphics accelerator.

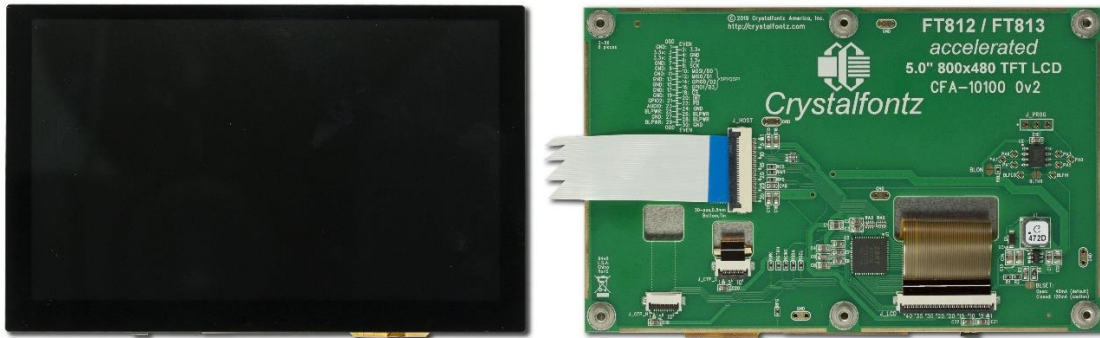

The traditional options for connecting a TFT to an embedded system make beautiful graphics a challenge. Traditionally, the choices were a very powerful processor that could support a frame buffer and RGB interface or, to write directly to TFT controller's frame buffer. These methods both rely on software to render graphics primitives. A simple non-anti-aliased image may take hundreds or even thousands of write operations. Sometimes, read-modify-write operations are required which doubles (or more) the necessary number of commands- further slowing the display performance.

Additionally, these methods require a lot GPIO or GPIO configured as the RGB interface, often requiring a larger processor package. There are examples of using SPI to control small TFT LCDs, but even on small displays the performance suffers.

Text poses another problem for traditional implementations of TFTs. Fonts require a lot of memory to store and rendering them to the frame buffer can be complex- especially if they need to be anti-aliased or rotated. The traditional solution is to support just a few bitmapped, non-anti-aliased fonts rendered only on the horizontal and vertical. Need to angle a font to put labels on some data? Not without a very complete and complex (and typically big and slow) graphic library.

Now imagine a display that solves the problems with traditional TFTs. One that accepts high-level commands, so writing just a few instructions completely describes a line. As long as we're imagining- what if that line was fully anti-aliased and fully adjustable in width? How about writing a few more commands and rendering beautiful anti-aliased text from a wide selection of fonts at any angle?

This is now a reality with the CFAF800480E1-050SC-A2 thanks to the FTDI/BridgeTek BT817 EVE graphics accelerator at the heart of the module. Embedded systems with 8-bit processors can now have beautiful and responsive displays that do not tax the host processor.

Ready to live the dream? Our demo code for the CFAF800480E1-050SC-A2 was written to fit on the Seeeduino v4.2 (a 3.3v clone of the Arduino Uno). As always, our source code is freely supplied and our displays are [fully supported](#).



### 3. Module Information

This module comprises the CFAF800480E1-050SC mounted to a graphic accelerator board. The graphic accelerator board boasts the FTDI/Bridgetek BT817 Embedded Video Engine (EVE). The CFAF800480E1-050SC-A2 is a 16M color 5-inch TFT graphic display module with a white LED backlight and capacitive touch panel. This display has in-plane switching, and is sunlight readable. The EVE chip handles all communication with the display and touchscreen.

Please see the [BT817 datasheet](#) for further reference.

### 4. Features

#### 4.1. TFT Display Module Features

- 5-inch 800x480 TFT LCD
- In Plane Switching – free viewing angle
- 5-point Capacitive touch
- High bright at 800 cd/m<sup>2</sup>
- Built-in Display Driver: ST7262 (or equivalent)
- Capacitive Touch Driver: GT911
- Operating Temperature: -20° - 70°C
- Storage Temperature: -30° - 80°C
- FTDI/BridgeTek BT817 EVE graphics accelerator
- SPI, QSPI
- Single +3.3V power supply (backlight supply can be 3.3v to 6v)
- Six 2-56 threaded mounting standoffs for simple mechanical design

#### 4.2. EVE Graphics Accelerator Features

- Supports multiple widgets for simplified design implementation
- User interface design software (PC) simplifies the design process
- Enhanced sketch processing
- Anti-aliasing of primitive displayed objects for higher-quality graphics
- Assorted graphical effects such as alpha-blending, shadows, transitions, wipes, etc.
- Programmable interrupt controller provides interrupts to host MCU
- Support playback of motion-JPEG encoded AVI videos
- Mono audio channel output with wave playback and built-in sound synthesizer
- PWM output for display backlight dimming control

#### 4.3. Module Information

The display, touch, backlight, and audio features are all controlled via the Embedded Video Engine (EVE) which appears to the host MCU as a memory-mapped SPI device. The host MCU sends commands and data over the EVE SPI serial protocol.

For detailed BridgeTek datasheets and other development information, see the Embedded Video Engine Documentation / Resources section below.

#### 4.4. Embedded Video Engine Documentation / Resources

- BT817 Datasheet: <https://www.crystalfontz.com/controllers/Bridgetek/BT81x/>
- BridgeTek Screen Designer Software: <https://brtchip.com/eve-toolchains/>
- BridgeTek Forum: <http://www.brtcommunity.com/index.php?board=7.0>
- BridgeTek Resources: <https://brtchip.com/bt81x/>
- FTDI Application Notes: <https://www.ftdichip.com/Support/Documents/AppNotes.htm>
- FTDI C232HM USB-SPI cable: <https://www.ftdichip.com/Products/Cables/USBMPSSSE.htm>



### 4.5. Embedded Video Engine Programmer's Model

The diagram below is a basic overview of the EVE programming model showing data flow paths to and from the SPI host interface to the memory and processing blocks of the embedded video engine.

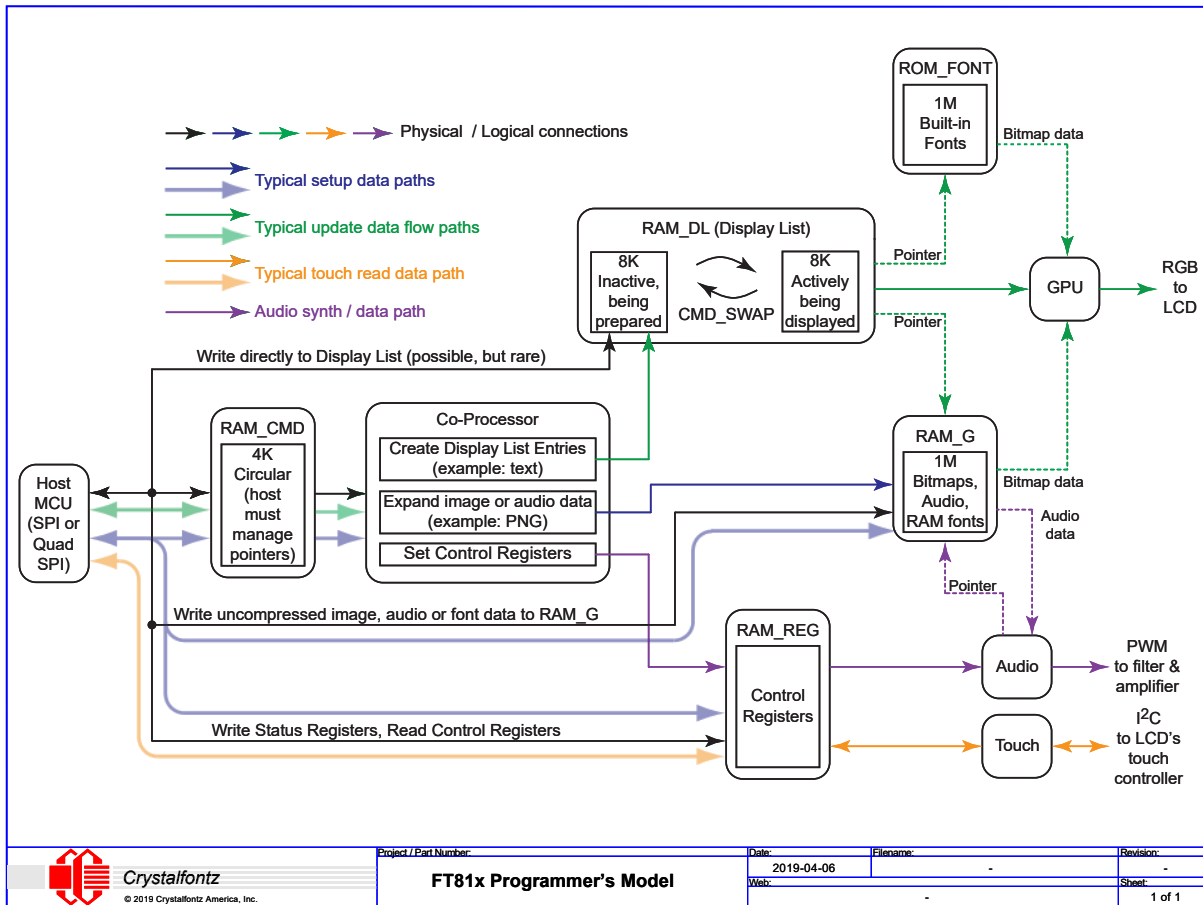

### 5. Mechanical Data

Item	Specification (mm)	Specification (inch, reference)
Overall Width, Height, and Depth	120.7 x 76.3 x 10.75	4.75 x 3.00 x 0.423
Viewing Area	109.00 x 65.80	4.29 x 2.59
Active Area	108.00 x 64.80	4.25 x 2.55
Pixel Pitch	0.135 x 0.135	0.005 x 0.005
Weight (Typical)	125 grams	4.4 ounces



## 6. Mechanical Drawing

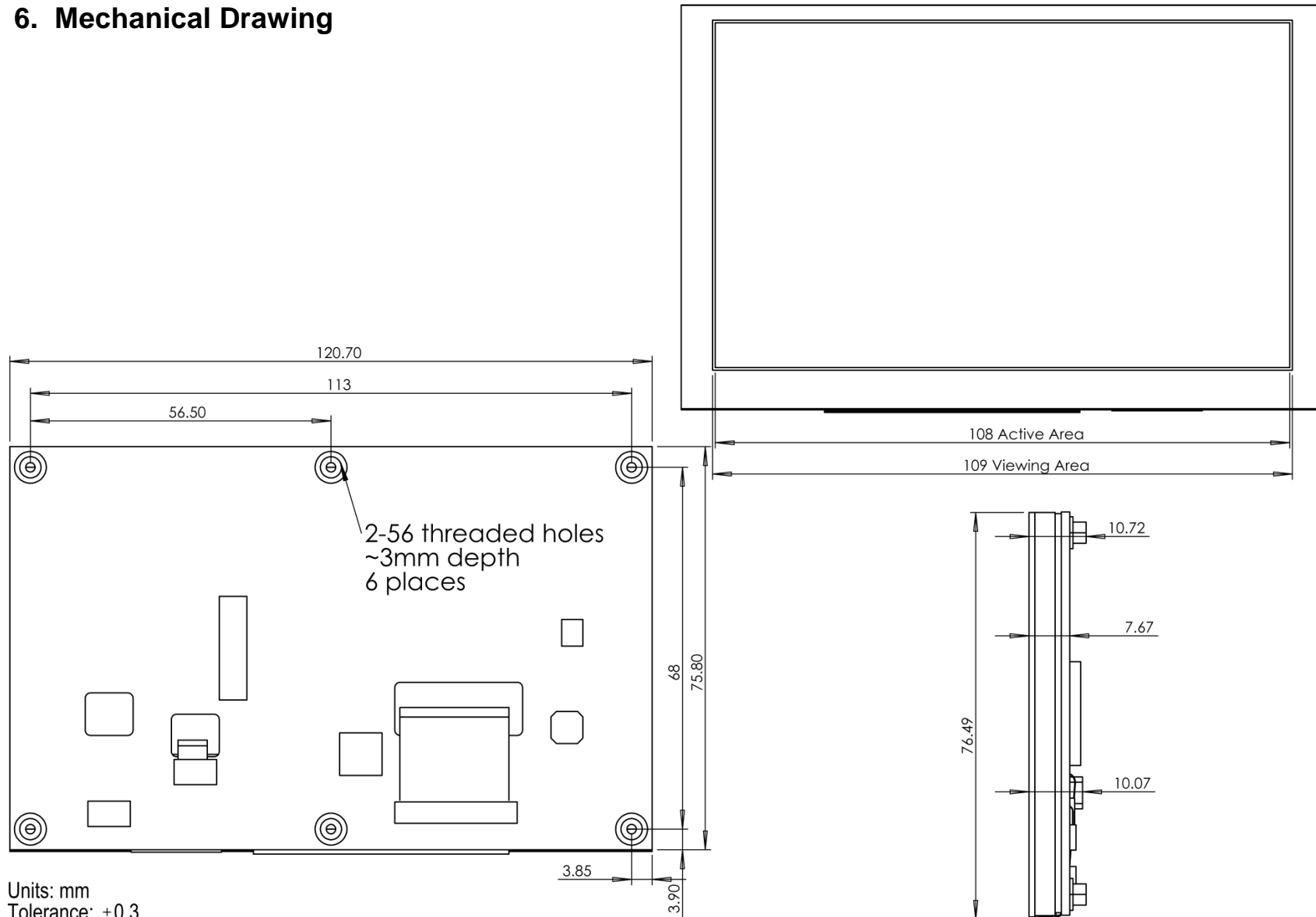



## 7. Interface Pin Function

Host data connection and power supply are achieved via a single 30 pin flat-cable connector (labeled J\_HOST) on the rear of the module. Any 30 pin FFC-FPC ZIF cable with a 0.5mm pitch and bottom contacts will be compatible with this module. We suggest the [6" WR-FFC-Y50](#) or the [12" WR-FFC-Y51](#).

J_HOST Connection			
Pin	Symbol	Signal Direction	Function
1	GND		Ground <sup>(1)</sup>
2	3V3		Logic Power Supply <sup>(1)</sup>
3	3V3		Logic Power Supply <sup>(1)</sup>
4	GND		Ground <sup>(1)</sup>
5	3V3		Logic Power Supply <sup>(1)</sup>
6	3V3		Logic Power Supply <sup>(1)</sup>
7	GND		Ground <sup>(1)</sup>
8	SCK	Input	SPI Clock
9	GND		Ground <sup>(1)</sup>
10	MOSI / D0	Input	SPI Single Mode: SPI MOSI SPI Dual/Quad Mode: SPI Data Line 0
11	GND		Ground <sup>(1)</sup>
12	MISO / D1	Output	SPI Single Mode: SPI MISO SPI Dual/Quad Mode: SPI Data Line 1
13	GND		Ground <sup>(1)</sup>
14	GPIO0 / D2	Input / Output	SPI Single/Dual Mode: General Purpose IO0 SPI Quad Mode: SPI Data Line 2
15	GND		Ground <sup>(1)</sup>
16	GPIO1 / D3	Input / Output	SPI Single/Dual Mode: General Purpose IO1 SPI Quad Mode: SPI Data Line 3
17	GND		Ground <sup>(1)</sup>
18	nCS	Input	SPI Slave Chip-Select
19	GND		Ground <sup>(1)</sup>
20	nINT	Output	Interrupt to Host
21	GPIO2		General purpose IO2
22	nPD	Input	Chip Power Down Mode
23	AUDIO PWM	Output	Audio PWM
24	GND		Ground <sup>(1)</sup>
25	BLPWR		Backlight Power Supply <sup>(1)</sup>
26	BLPWR		Backlight Power Supply <sup>(1)</sup>
27	GND		Ground <sup>(1)</sup>
28	BLPWR		Backlight Power Supply <sup>(1)</sup>
29	BLPWR		Backlight Power Supply <sup>(1)</sup>
30	GND		Ground <sup>(1)</sup>

*Note: It is recommended that these pins are all connected to their respective power source. Not doing so may produce unpredictable results or damage the display module.*





## 8. Absolute Maximum Ratings

Parameter	Symbol	Min	Max	Unit	Notes
Supply Voltage for Logic	V <sub>DD</sub>	-0.5	3.96	V	(1)(2)(3)
Operating Temperature	T <sub>OP</sub>	-20	70	°C	-
Storage Temperature	T <sub>STG</sub>	-30	80	°C	-

Notes:

- (1) These are stress ratings only. Extended exposure to the absolute maximum ratings listed above may affect device reliability or cause permanent damage.
- (2) Functional operation should be restricted to the limits in the Electrical Characteristics table below.

## 9. TFT Electrical Characteristics

Item	Symbol	Min	Typ	Max	Unit
Supply Voltage for Logic	V <sub>DD</sub>	3.0	3.3	3.6	V
Logic Supply Current	I <sub>DD</sub>	-	20	-	mA
High-level Input	V <sub>IH</sub>	0.7 x V <sub>DDI</sub>	-	V <sub>DDI</sub>	V
Low-level Input	V <sub>IL</sub>	DGND	-	0.3 x V <sub>DDI</sub>	V
High-level Output	V <sub>OH</sub>	V <sub>DDI</sub> - 0.4	-	V <sub>DDI</sub>	V
Low-level Output	V <sub>OL</sub>	DGND	-	DGND + 0.4	V

## 10. Optical Characteristics

Item	Symbol	Condition	Min	Typ	Max	Unit
View Angle	(V)θ		-	160	-	deg
	(H)φ		-	160	-	deg
Contrast Ratio	CR		800	1000	-	-
Response Time	T <sub>rise</sub> +T <sub>fall</sub>		-	30	40	ms
Surface Luminance		Θ=0	700	800	-	cd/m <sup>2</sup>

## 11. Backlight Characteristics

Item	Symbol	Min	Typ	Max	Unit
Supply Voltage	BLPWR	2.7	5.0	5.5	V
Supply Current (BLPWR= 3.3v)	I <sub>BLPWR</sub>	-	70	-	mA
Supply Current (BLPWR=5v)	I <sub>BLPWR</sub>	-	140	-	
LED Lifetime			30000		hours

Notes:

- (1) Typical voltage value is 5.0v. Using a voltage below 4v will result in a lower maximum brightness of the LCD.
- (2) Lifetime is defined as the amount of time when the luminance has decayed to <50% of the initial value, and this value is provided as an estimate only.



## 12. Getting Started

In earlier stages of development, consider the complete CFAF800480E1-050SC-A2-2 kit, which includes:

- CFAF800480E1-050SC-A1-1 display module
- [CFA10098](#) EVE adapter board
- 30-position, 0.5mm pitch flat flex cable (such as the [6" WR-FFC-Y50](#) or the [12" WR-FFC-Y51](#))
- 0.1" female-to-female jumper wires ([WR-JMP-Y40](#))
- Seeeduino v4.2 ([CFAPN15062](#))

The CFAF800480E1-050SC-A2-2 ships connected as shown (though the FFC may be disconnected to prevent breakages):

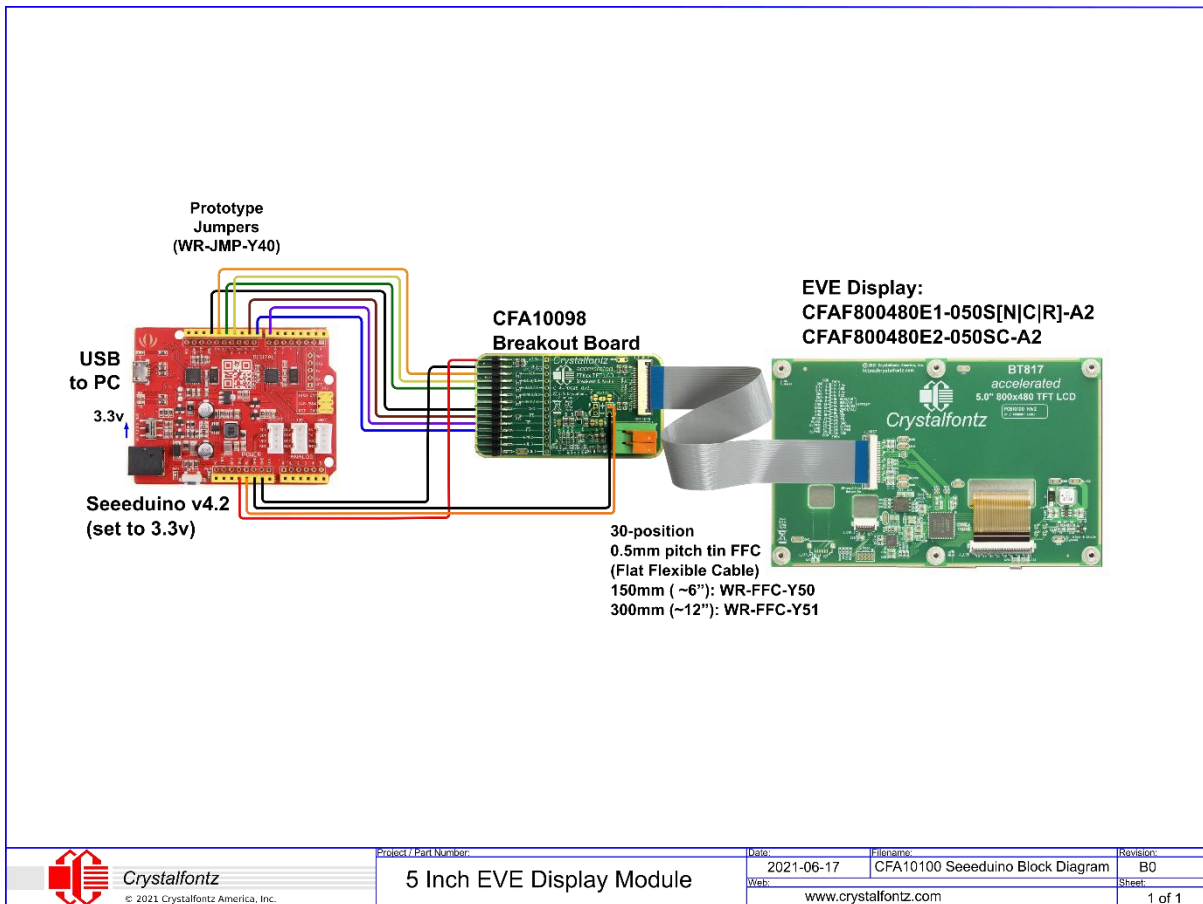

If your kit ships with the flex cable disconnected, take note of the orientation of the flat-flex-cable, and use of the locking clip in the following photos.

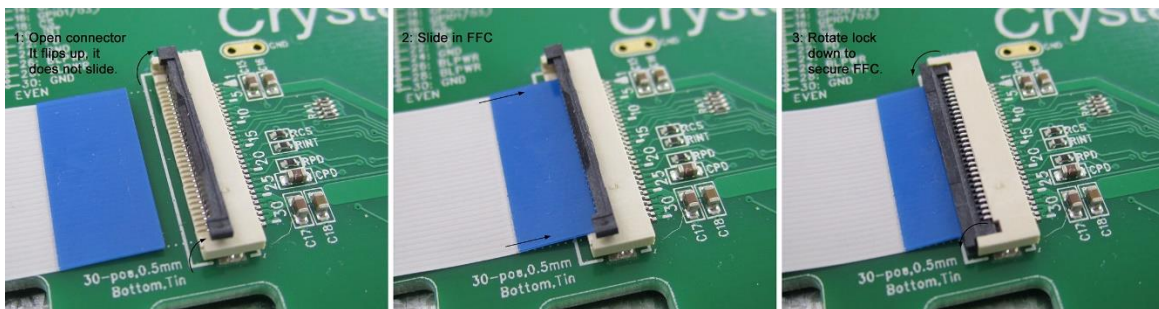



## 12.1. Getting Started with your CFAF800480E1-050SC-A1-2

### 12.1.1. Components

- CFAF800480E1-050SC-A1-1 display module
- [CFA10098](#) EVE adapter board
- Flat-flex-cable (6" [WR-FFC-Y50](#) & 12" [WR-FFC-Y51](#))
- 0.1" female-to-female jumper wires ([WR-JMP-Y40](#))
- Seeeduino v4.2 ([CFAPN15062](#))
- USB Cable ([WR-USB-Y27](#))
- Bench supply set to 3.3v, rated for at least 1000mA

### 12.1.2. Hardware Procedure

- Following the Seeeduino Block Diagram, above, connect the components.
- Supply 3.3v from a bench supply (rated for at least 1000mA) to the CFA10098
- Connect the USB cable to your PC

### 12.1.3. Firmware Procedure

- Download and install [Arduino IDE](#) software (or equivalent IDE)
- Download the example sketch available on [the product page](#), and open it in the Arduino IDE.
- Build and upload the sketch to the Seeeduino

## 12.2. Getting started with the CFAF800480E1-050SC-A1-1 and a Windows PC

### 12.2.1. Components

- CFAF800480E1-050SC-A1-1 display module
- [CFA10098](#) EVE adapter board
- Flat-flex-cable (6" [WR-FFC-Y50](#) & 12" [WR-FFC-Y51](#))
- FTDI [C232HM-DDHSL-0](#) USB to SPI cable
- Bench supply set to 3.3v, rated for at least 1000mA



### 12.2.2. Hardware Procedure

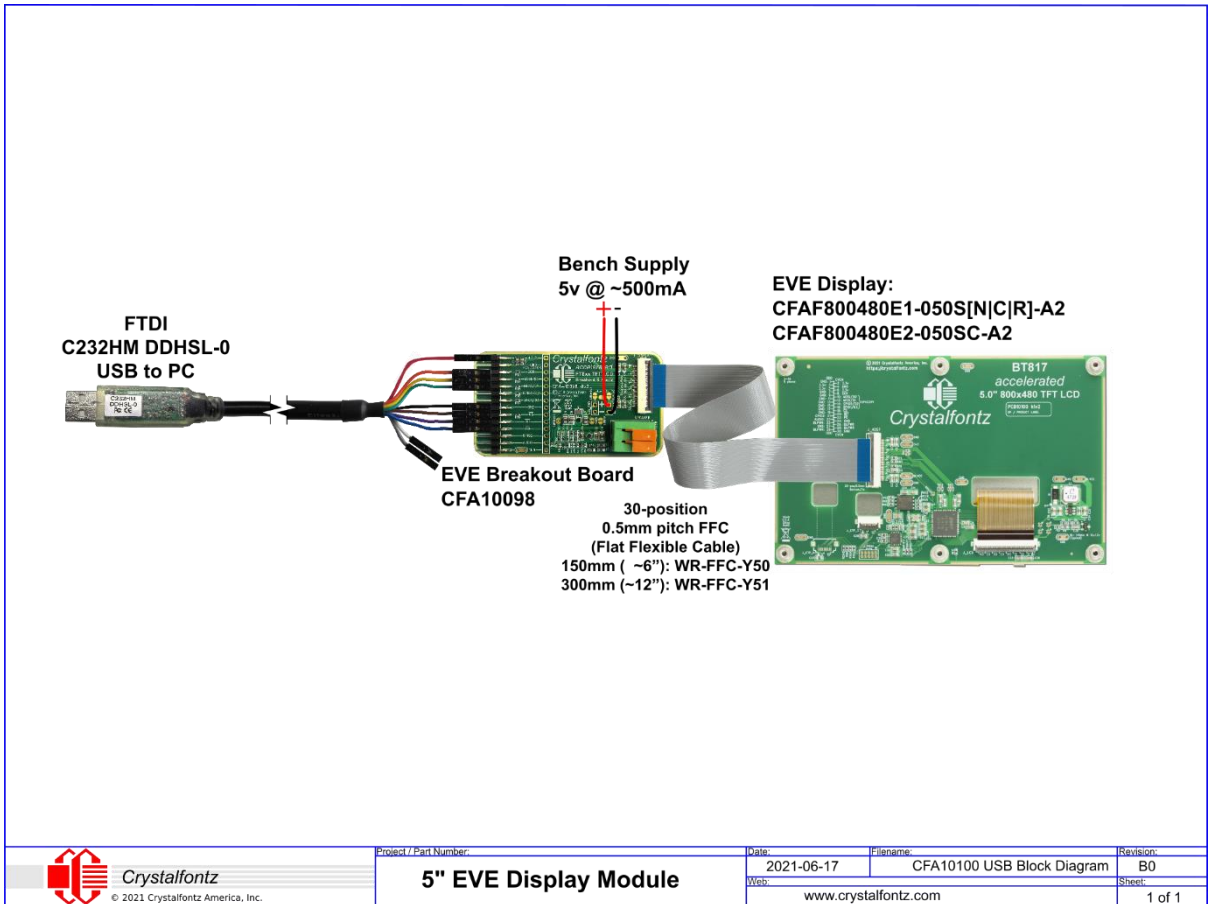

- Connect the CFA10098 to the CFAF800480E1-050SC-A1-1 using the FFC
- Connect the CFA10098 to the C232HM-DDHSL-0 USB adapter
- Connect 3.3v from a bench supply (rated for at least 1000mA) to the CFA10098
- Connect the USB to SPI cable to your Windows PC

### 12.2.3. Software Procedure:

- Download and install the FTDI PC demonstration application from [Bridgetek's website](#).
- Download, open, build and run the example EVE application [available on GitHub](#).

*In order to modify and compile the FTDI PC demonstration program, you will need to download Visual Studio. You can use the free version but you may need to register with Microsoft.*

## 12.3. Getting started, hardware, with CFAF800480E1-050SC-A1-1 and your PCB

### 12.3.1. Components

- CFAF800480E1-050SC-A1-1 display module
- ZIF connector: 30-position, 0,5mm pitch, tin contact mounted to your custom PCB
- Flat-flex-cable (6" [WR-FFC-Y50](#) & 12" [WR-FFC-Y51](#))

### 12.3.2. Procedure

- Connect the FFC to the ZIF connector on your PCB
- Connect the FFC to the ZIF connector on the CFAF800480E1-050SC-A1-1

*Note that your power supply must be able to supply enough current to drive the backlight.*

## 12.4. Troubleshooting

Please contact [support@crystalfontz.com](mailto:support@crystalfontz.com) if you need help troubleshooting your module.



## 13. Care and Handling Precautions

For optimum operation of the CFAF800480E1-050SC-A2 and to prolong its life, please follow the precautions described below.

### 13.1. ESD (Electrostatic Discharge)

If present, the USB D+ & D- lines have enhanced ESD protection following industry standard USB2 practice.

The remainder of this circuitry is industry standard CMOS logic and susceptible to ESD damage. Please use industry standard antistatic precautions, as you would for any other static sensitive device such as expansion cards, motherboards, or integrated circuits. Ground your body, work surfaces, and equipment.

### 13.2. Design and Mounting

- The exposed surface of the display is either a touch-sensitive panel or a polarizer laminated on top of the glass. To protect the surface from damage, the module ships with a protective film over the display. Please peel off the protective film slowly. Peeling off the protective film abruptly may generate static electricity.
- If the display does not have a touch-sensitive panel, to protect the soft plastic polarizer from damage, place a transparent plate (for example, acrylic, polycarbonate or glass), in front of the module, leaving a small gap between the plate and the display surface.
- Do not disassemble or modify the module.
- Do not modify the six tabs of the metal bezel or make connections to them.
- Do not reverse polarity to the power supply connections. Reversing polarity will immediately ruin the module.

### 13.3. Mechanical Shock, Impact, Torque, or Tension

- Do not expose the module to strong mechanical shock, impact, torque, or tension.
- Do not drop, toss, bend, or twist the module.
- Do not place weight or pressure on the module.

### 13.4. LCD Panel Breakage

- If the LCD panel breaks, be careful to not get the liquid crystal fluid in your mouth or eyes.
- If the liquid crystal fluid touches your skin, clothes, or work surface, wash it off immediately using warm soapy water.

### 13.5. Cleaning

- The display surface can easily be scratched or become hazy, so use extra care when you clean it.
- Do not clean the display surface with liquids.
- If the display surface becomes dusty, carefully blow it off with clean, dry, oil-free compressed air.
- Use the removable protective film to remove smudges (for example, fingerprints), and any foreign matter. If you no longer have the protective film, use standard transparent office tape (for example, Scotch® brand "Crystal Clear Tape").
- If the above methods are not adequate, gently wipe using a very soft, clean, dry, lint free cloth (such as a microfiber towelette).
- Contact with moisture may permanently spot or stain the polarizer.

### 13.6. Operation

- Protect the module from ESD and power supply transients.
- Observe the operating temperature limitations: a minimum of -20°C to a maximum of +70°C with minimal fluctuation. Operation outside of these limits may shorten life and/or harm display.
- At lower temperatures of this range, response time is delayed.



- At higher temperatures of this range, display becomes dark (you may need to adjust the contrast).
- Operate away from dust, moisture, and direct sunlight.
- Adjust backlight brightness so the display is readable, but not too bright.
- Dim or turn off the backlight during periods of inactivity to conserve the backlight lifetime.

### 13.7. Storage and Recycling

- Store in an ESD-approved container away from dust, moisture, and direct sunlight.
- Observe the storage temperature limitations: -30°C minimum, +80°C maximum with minimal fluctuation. Rapid temperature changes can cause moisture to form, resulting in permanent damage.
- Do not allow weight to be placed on the module while in storage.
- Please recycle your outdated Crystalfontz modules at an approved facility.