



GRAPHIC LCD MODULE DATASHEET



Datasheet Release Date 2024-10-14
for
CFAG19232C1-YYH-TT

Crystalfontz America, Inc.

12412 East Saltese Avenue
Spokane Valley, WA 99216-0357
Phone: 888-206-9720
Fax: 509-892-1203
Email: support@crystalfontz.com
URL: www.crystalfontz.com

CONTENTS

1. General Information	3
2. Module Description	4
3. Features	4
4. Mechanical Data	4
5. Mechanical Drawing	5
6. Interface Pin Function	6
7. System Block Diagram	6
8. Absolute Maximum Ratings	7
9. Electrical Characteristics	7
10. Optical Characteristics	7
11. Backlight Information	8
12. LCD Module Precautions	9

1. General Information

Datasheet Revision History

Datasheet Release: **2024-10-14**
Datasheet for the CFAG19232C1-YYH-TT graphic LCD display module.

Product Change Notifications

You can check for or subscribe to [Part Change Notices](#) for this display module on our website.

Variations

Slight variations between lots are normal (e.g., contrast, color, or intensity).

Volatility

This display module has volatile memory.

Disclaimer

Certain applications using Crystalfontz America, Inc. products may involve potential risks of death, personal injury, or severe property or environmental damage ("Critical Applications"). CRYSTALFONTZ AMERICA, INC. PRODUCTS ARE NOT DESIGNED, INTENDED, AUTHORIZED, OR WARRANTED TO BE SUITABLE FOR USE IN LIFE-SUPPORT APPLICATIONS, DEVICES OR SYSTEMS OR OTHER CRITICAL APPLICATIONS. Inclusion of Crystalfontz America, Inc. products in such applications is understood to be fully at the risk of the customer. In order to minimize risks associated with customer applications, adequate design and operating safeguards should be provided by the customer to minimize inherent or procedural hazard. Please contact us if you have any questions concerning potential risk applications.

Crystalfontz America, Inc. assumes no liability for applications assistance, customer product design, software performance, or infringements of patents or services described herein. Nor does Crystalfontz America, Inc. warrant or represent that any license, either express or implied, is granted under any patent right, copyright, or other intellectual property right of Crystalfontz America, Inc. covering or relating to any combination, machine, or process in which our products or services might be or are used.

All specifications in datasheets on our website are, to the best of our knowledge, accurate but not guaranteed. Corrections to specifications are made as any inaccuracies are discovered.

Company and product names mentioned in this publication are trademarks or registered trademarks of their respective owners.

Copyright © 2024 by Crystalfontz America, Inc., 12412 East Saltese Avenue, Spokane Valley, WA 99216 U.S.A.

2. Module Description

This is a yellow-green monochrome graphic LCD display module with a yellow-green LED backlight. This display has a built-in Sitronix ST7920 controller.

Please see [Sitronix ST7920 LCD Controller Datasheet](#) for further reference.

3. Features

- 192*32 Dot Matrix
- Built-in Controller: ST7920 (or equivalent)
- Viewing Direction: 6 o'clock
- STN Positive, Yellow-green, Transflective Mode
- +5V Power Supply
- Negative Voltage Generator
- Operating Temperature: -20°C to +70°C
- Storage Temperature: -30°C to +80°C
- 1/32 Duty
- Interface: 6800 4-bit or 8-bit parallel

4. Mechanical Data

Item	Specification (mm)	Specification (inch, reference)
Overall Width and Height	116.0 (W) x 37.0 (H) x 13.9 (D)	4.567 (W) x 1.457 (H) x 0.547 (D)
Viewing Area	85.0 (W) x 18.6 (H)	3.346 (W) x 0.732 (H)
Active Area	80.6 (W) x 15.96 (H)	3.173 (W) x 0.641 (H)
Dot Size	0.38 (W) x 0.46 (H)	0.015 (W) x 0.018 (H)
Dot Pitch	0.42 (W) x 0.50 (H)	0.017 (W) x 0.019 (H)
Weight (Typical)	52 grams	1.8 ounces

5. Mechanical Drawing

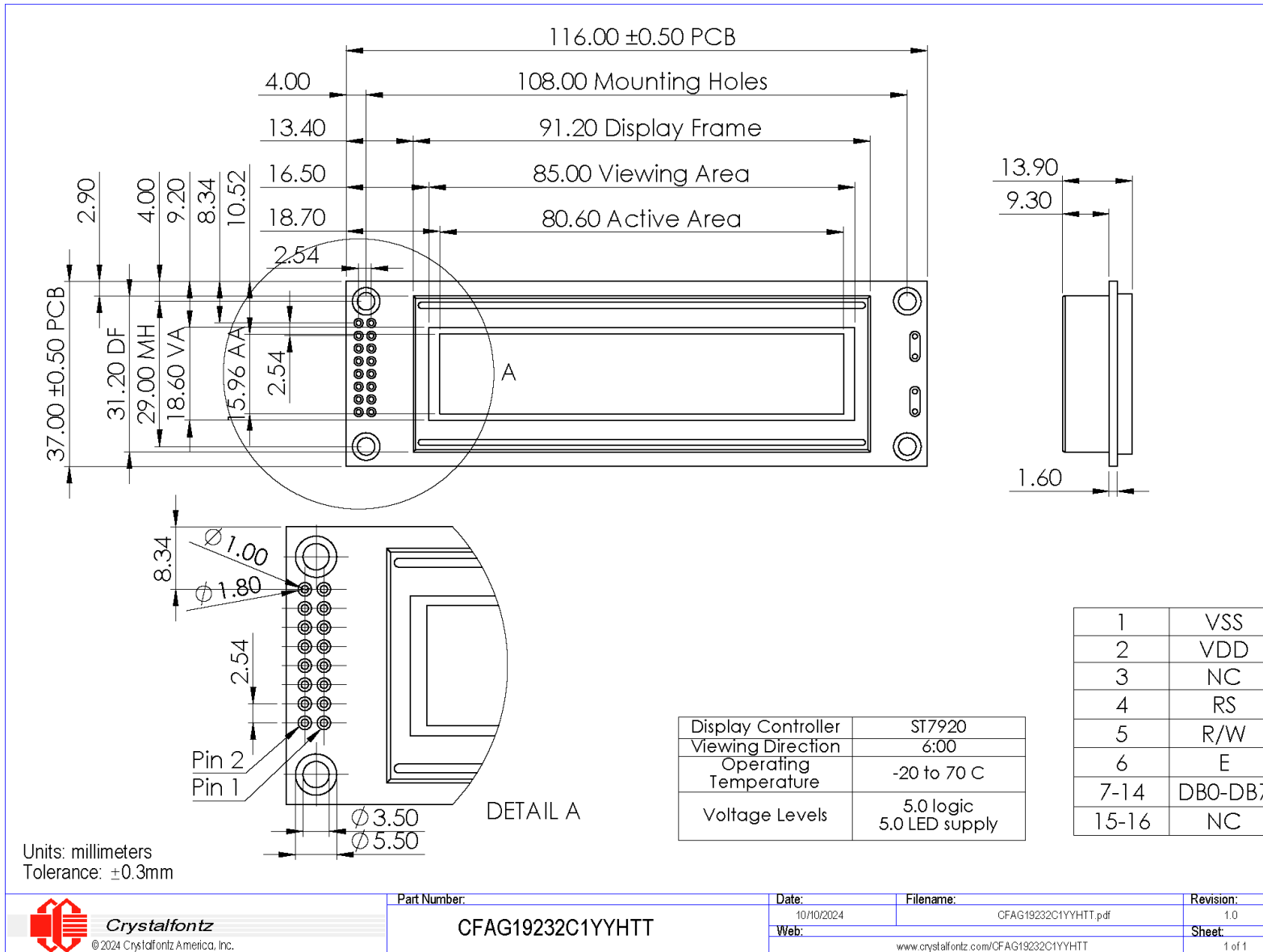

6. Interface Pin Function

Pin No.	Symbol	Level	Function
1	V _{SS}	0v	Ground
2	V _{DD}	5.0v	Supply Voltage for Logic
3	NC	-	No Connection
4	RS	H/L	H: Data L: Instruction Code
5	R/W	H/L	H: Read L: Write
6	E	H, H→L	Chip Enable Signal
7	DB0	H/L	Data Bus Line
8	DB1	H/L	Data Bus Line
9	DB2	H/L	Data Bus Line
10	DB3	H/L	Data Bus Line
11	DB4	H/L	Data Bus Line
12	DB5	H/L	Data Bus Line
13	DB6	H/L	Data Bus Line
14	DB7	H/L	Data Bus Line
15	NC	-	No Connection
16	NC	-	No Connection

7. System Block Diagram

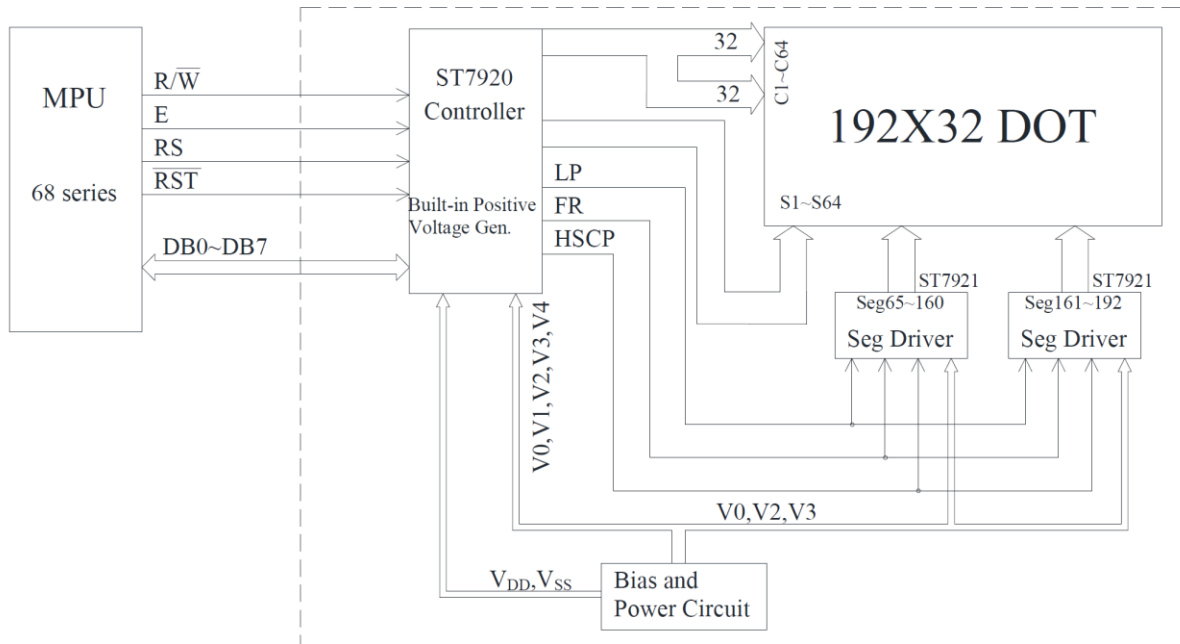

8. Absolute Maximum Ratings

Parameter	Symbol	Min	Typ	Max	Unit	Notes
Supply Voltage for Logic	$V_{DD} - V_{SS}$	-0.3	-	5.5	V	(1)(2)
Input Voltage	V_{IN}	-0.3	-	$V_{DD} + 0.3$	V	-
Operating Temperature	T_{OP}	-20	-	+70	°C	-
Storage Temperature	T_{ST}	-30	-	+80	°C	-

Notes:

(1) These are stress ratings only. Extended exposure to the absolute maximum ratings listed above may affect device reliability or cause permanent damage.

(2) Functional operation should be restricted to the limits in the Electrical Characteristics table below.

9. Electrical Characteristics

Item	Symbol	Condition	Min	Typ	Max	Unit
Supply Voltage for Logic	$V_{DD} - V_{SS}$	-	4.5	5.0	5.5	V
High-level Input	V_{IH}	-	0.7 V_{DD}	-	V_{DD}	V
Low-level Input	V_{IL}	-	-0.3	-	0.6	V
High-level Output	V_{OH}	-	0.8 V_{DD}	-	V_{DD}	V
Low-level Output	V_{OL}	-	-	-	0.4	V
Supply Current	I_{DD}	$V_{DD} = 5.0V$	1.48	2.0	2.27	mA

10. Optical Characteristics

Item	Symbol	Condition	Min	Typ	Max	Unit
View Angle	θ	$CR \geq 2$	0	-	20	$\phi = 180^\circ$
	θ	$CR \geq 2$	0	-	40	$\phi = 0^\circ$
	θ	$CR \geq 2$	0	-	30	$\phi = 90^\circ$
	θ	$CR \geq 2$	0	-	30	$\phi = 270^\circ$
Contrast Ratio	CR	-	-	3	-	-
Response Time	T rise	-	-	150	200	ms
	T fall	-	-	150	200	ms

11. Backlight Information

Parameter	Symbol	Condition	Min	Typ	Max	Unit	Notes
Supply Current	I_{LED}	V=5.0v	168	210	252	mA	(1)(2)
Supply Voltage	V	-	4.9	5.0	5.1	V	-
Reverse Voltage	V_R	-	-	-	8	V	-
Luminance (without LCD)	I_V	$I_{LED}=210mA$	210	260	-	cd/m ²	-
LED Lifetime	-	$I_{LED}=210mA$ 25°C, 50- 60% RH	-	100K	-	Hrs	(1)(2)
Color	Yellow-green						

Notes:

- (1) Supply current minimum value is only for reference since the LED brightness efficiency keeps enhancing. Current consumption becomes less and less to achieve the same luminance.
- (2) Lifetime is defined as the amount of time when the luminance has decayed to <50% of the initial value (100K hours is an estimate for reference only).

12. LCD Module Precautions

These precautions help ensure personal safety, module performance, and compliance of environmental regulations when using an LCD module.

12.1. Modules

- Avoid excessive physical and electrical shocks to module.
- Do not drop, bend, or twist the LCD display module.
- Do not make extra holes, modify the shape, or change the components of the printed circuit board.
- Do not disassemble the LCD display module.
- Do not operate the LCD display module outside the absolute maximum rating.
- Only solder to the I/O terminals.
- Store in an anti-static electricity container and clean environment.
- Do not display static information for long periods of time to avoid burn in.
- Crystalfontz has the right to change passive components on the display module. Resistors, capacitors and other passive components may have different appearance and color.
- Crystalfontz has the right to change the PCB revision/version in order to satisfy the supply stability, management optimization, the best product performance, etc., under the premise of not affecting the electrical characteristics and external dimensions.

12.2. Handling Precautions

- The display panel is made of glass. Do not apply mechanical impacts, stress or pressure to the LCD display module.
- Pressure applied to or near the display surface may damage the cell structure.
- If the display panel is accidentally broken and the internal organic substance leaks out, do not inhale or touch the organic substance.
- The polarizer covering the surface of the LCD display module is soft and can be easily scratched. Cover the polarizer in the final design.
- Clean the surface of the polarizer using Scotch Mending Tape No. 810 or an equivalent
 - Never breathe on the surface or wipe the surface using a cloth containing solvent such as ethyl alcohol, as the surface of the polarizer will become cloudy.
 - Water, ketone, and aromatic solvents may ruin the polarizer.
- Do not over bend the film with electrode pattern layouts. This can effect the display performance.

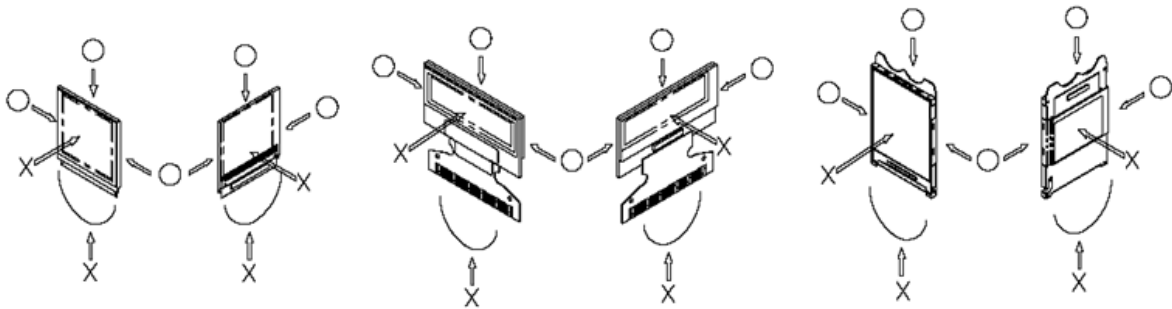

- Do not apply stress to the LSI chips and the surrounding molded sections.
- Do not apply input signals while the logic power is off.
- Prevent damage by electrostatic discharge (ESD) when handling the LCD display module:
 - Ground personnel handling LCD display modules.
 - Ground tools used for assembly such as soldering irons.
 - To suppress generation of ESD, avoid carrying out assembly work under dry environments.
 - Remove the protective film applied to the display panel slowly as ESD may be generated when removing the film.
- Protective film is applied to the surface of the display panel. Remove the film before assembly. If the LCD display module has been stored for a long period of time, residue adhesive material of the protection film may remain on the surface of the display panel after the film has been removed. In such a case, remove the residue material as discussed above.

12.3. Storing Precautions

- Store the LCD display modules in ESD preventative bags. Avoid exposure to direct sunlight and fluorescent lamps. Avoid high temperature and high humidity environments and low temperature (less than 0°C) environments. We recommend storing these modules in the packaged state in which they were shipped from Crystalfontz.
- Do not let water drops or dew adhere to the packages or bags.
- If electric current is applied when water is on the surface of the LCD display module, the module may become dewed. If a dewed LCD display module is placed under high humidity environments the electrodes may become corroded.

12.4. Designing Precautions

- The absolute maximum ratings cannot be exceeded for LCD display module. If these values are exceeded, panel damage may happen.
- Satisfy the VIL and VIH specifications and, ensure the signal line cable is as short as possible to avoid signal noise.
- Install excess current preventative unit (fuses, etc.) to the power circuit. Recommend value: 0.5A
- Avoid occurrence of mutual noise interference with the neighboring devices.
- When fastening the LCD display module, fasten the external plastic housing section. If the power supply to the LCD display module is forcibly shut down, by such errors as taking out the main battery while the LCD display panel is in operation, we cannot guarantee the quality of this LCD display module.
- Connection (contact) to any other potential than the above may lead to rupture of the IC.

12.5. Disposing Precautions

- Request qualified companies handle the industrial waste when disposing of the LCD display modules. Observe all relevant laws and regulations.

12.6. Other Precautions

- When an LCD display module is operated for a long period of time with a fixed pattern, the fixed pattern may remain as an after image or a slight contrast deviation may occur.
 - If the operation is interrupted and left unused for a while, normal state can be restored.
 - This will not cause a problem in the reliability of the module.
- To protect the LCD display module from performance drops by static electricity rapture, etc., do not touch the following sections whenever possible while handling the LCD display modules.
 - Pins and electrodes
 - Pattern layouts such as the TCP & FPC
- With this LCD display module, the LCD driver is exposed. If this LCD driver is exposed to light, malfunctioning may occur. Design the product and installation method so that the LCD driver may be shielded from light in actual usage and during the inspection processes.
- Although this LCD display module stores the operation state data by the commands and the indication data, when excessive external noise, etc. enters into the module, the internal status may be changed. Therefore, it is necessary to take appropriate measures to suppress noise generation or to protect from influences of noise on the system design.
- Periodically refresh the operation statuses in the software (reset the commands and retransfer the display data), to cope with catastrophic noise.
- Resistors, capacitors, and other passive components will have different appearance and color caused by the different supplier.
- Crystalfontz has the right to upgrade and modify the product function